

THIS DRAWING IS UNPUBLISHED. RELEASED FOR PUBLICATION
 © COPYRIGHT - By - ALL RIGHTS RESERVED.

REVISIONS					
P	LTR	DESCRIPTION	DATE	DWN	APVD
	G1	REVISED PER ECO-19-019022	19DEC2019	RS	JO

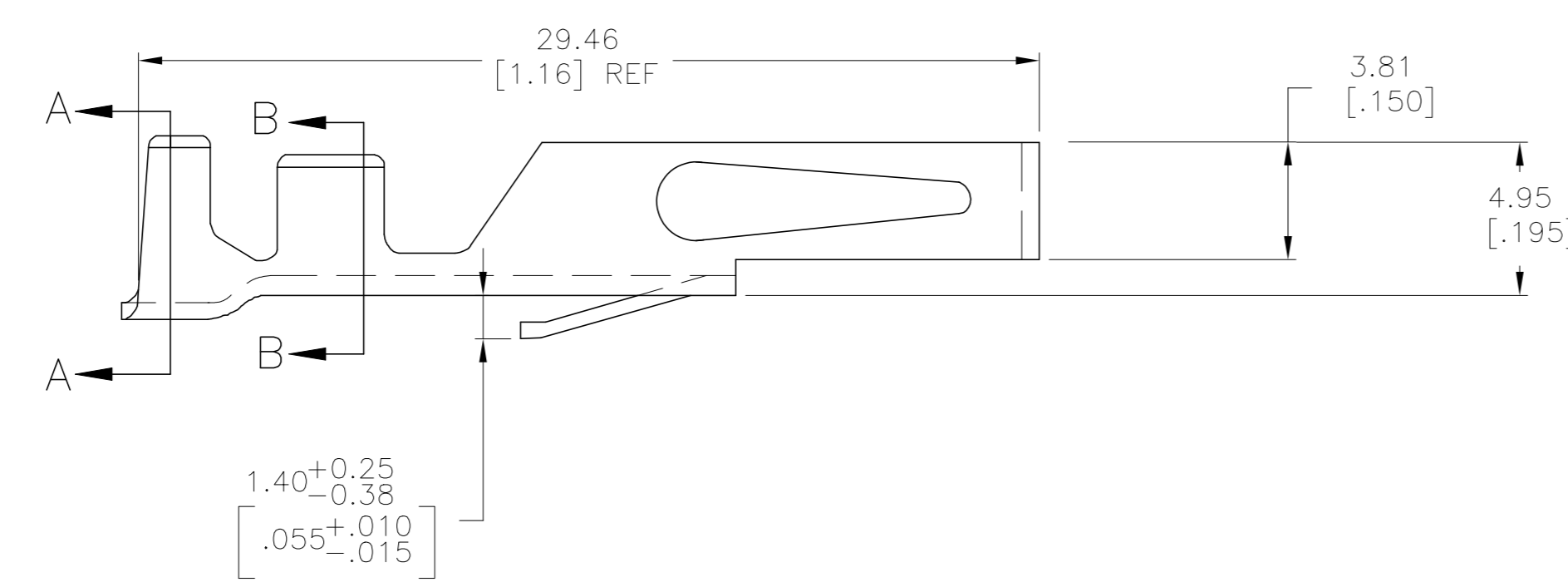
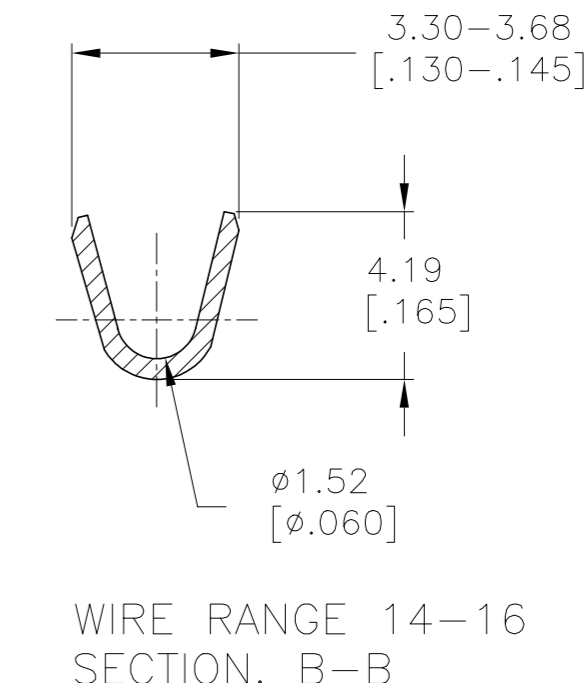
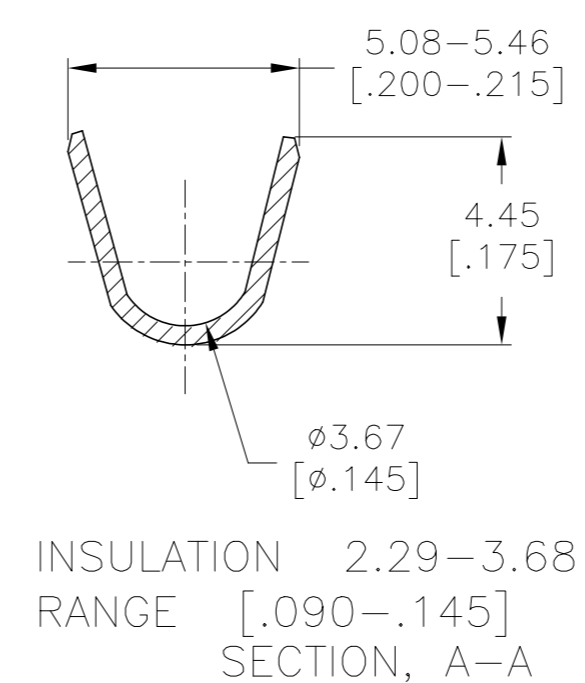
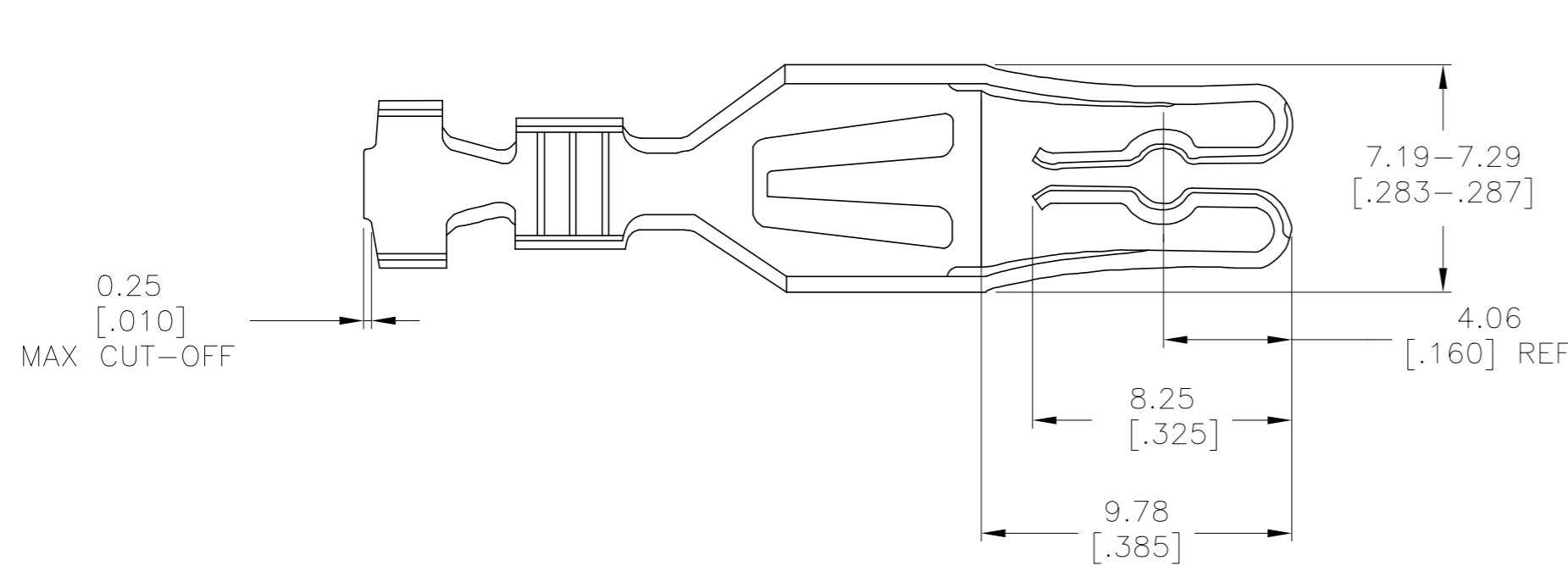

- 1 0.0038 (.000150) MIN BRIGHT TIN-LEAD OVER 0.00076 (.000030) MIN NICKEL.
- 2 0.0038 (.000150) MIN MATTE TIN OVER 0.00076 (.000030) MIN NICKEL.

2	5-530518-1
1	530518-1
FINISH	PART NO

THIS DRAWING IS A CONTROLLED DOCUMENT.		DWN	15 MAY 75	TE TE Connectivity	
		CHK	15 MAY 75		
DIMENSIONS: mm [INCHES]		APVD	16 MAY 75	NAME	
TOLERANCES UNLESS OTHERWISE SPECIFIED:		PRODUCT SPEC			
0 PLC ± -		APPLICATION SPEC			
1 PLC ± -		WEIGHT			
2 PLC ± -		SCALE			
3 PLC ± .005		SHEET			
4 PLC ± -		REV			
ANGLES ± -		CUSTOMER DRAWING			
MATERIAL ALLOY CDA-194		SIZE A2		CAGE CODE 00779	DRAWING NO C=530518
FINISH 1 2		RESTRICTED TO		1 of 1	