

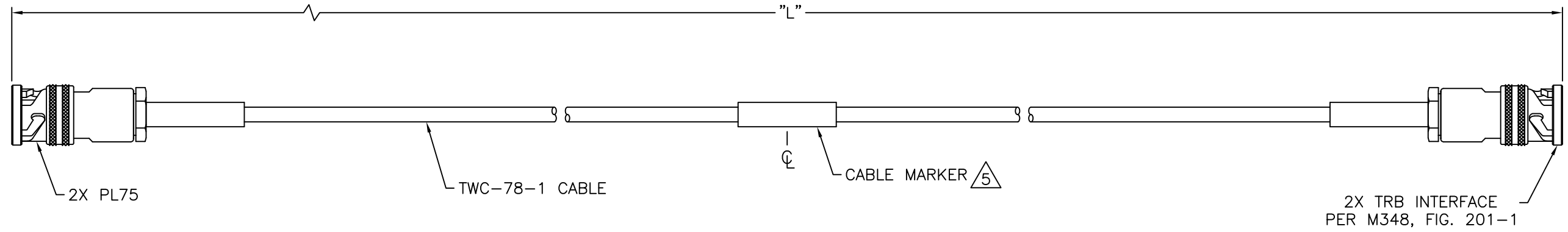

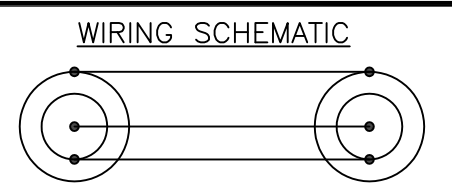

REV	ECO	DATE
001	57750	10/16/2020

TABLE 1		
MODEL NUMBER	"L"	MARKER 
21-20-M1.0	1.0 M	21-20-M1.0 14949 #####
21-20-M1.5	1.5 M	21-20-M1.5 14949 #####
21-20-M2.0	2.0 M	21-20-M2.0 14949 #####
21-20-M2.5	2.5 M	21-20-M2.5 14949 #####
21-20-M3.0	3.0 M	21-20-M3.0 14949 #####
21-20-M3.5	3.5 M	21-20-M3.5 14949 #####
21-20-M4.0	4.0 M	21-20-M4.0 14949 #####
21-20-M4.5	4.5 M	21-20-M4.5 14949 #####
21-20-M5.0	5.0 M	21-20-M5.0 14949 #####



NOTES: UNLESS OTHERWISE SPECIFIED.

1. WORKMANSHIP PER IPC/WHMA-A-620, CLASS 3, SECTION 13.
-  2. TOLERANCE PER IPC/WHMA-A-620, SECTION 11.1
3. TESTING:
 - 3.1 CONTINUITY
 - 3.2 DWV: 400 VRMS
4. BEND RADIUS (MIN): 1.5
-  5. MARKERS:
 - 5.1 MARKER PER TABLE 1.
 - 5.2 ##### = LOT CODE

 <small>NOTICE: The information in this drawing is PROPRIETARY and must not be used without the permission of Cinch Connectivity Solutions. It may contain data whose export is restricted. Verify status prior to exporting.</small> <small>INTERPRET DRAWING IN ACCORDANCE WITH ASME Y14.5-2018</small>	Model No.	21-20-MX.X	Title: TROMPETER	
	RoHS2	14949	CABLE ASSEMBLY, METRIC, TRB PLUG TO TRB PLUG	
	2011/65/EU	Cage Code	C_21-20-MX.X	
	UNLESS OTHERWISE SPECIFIED UNITS: INCH	3RD ANGLE PROJECTION	Rev.	001
	Drawn By:	C. MONAHAN	DATE:	10/15/2020
	SIZE	B	DO NOT SCALE DRAWING	Workmanship Std: SEE NOTES
				SHEET 1 OF 1