

REVISIONS				
P	LTR	DESCRIPTION	DATE	APVD
R1	ECR-22-138429		18MAY2022	LP DSC

**AMP**  
WIRE RANGE

---

26-24 AWG  
STRANDED

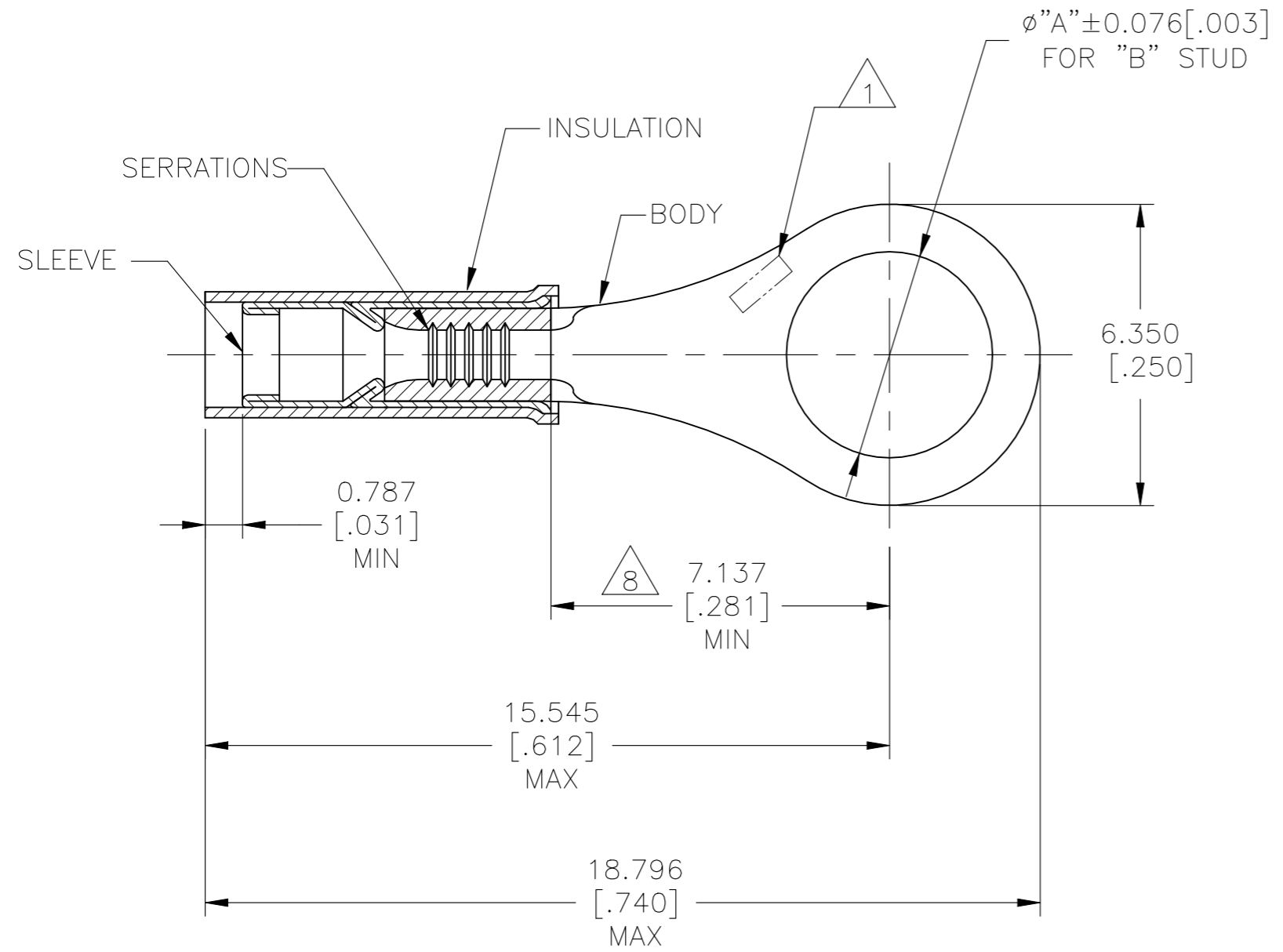

- 1 STAMP AMP, APPROX AS SHOWN
- 2 BODY MATERIAL THK:  $0.457 \pm 0.051 [.018 \pm .002]$
- 3 MATERIAL:  
BODY & SLEEVE - COPPER PER ASTM B152, ANNEALED  
INSULATION - PTFE PER ASTM D4895
- 4 FINISH:  
BODY - NICKEL PLATE  $0.00762 [.00030]$  AVG EXT THK PER  
SAE AMS-QQ-N-290  
SLEEVE - NICKEL PLATE  $0.001651 [.000065]$  AVG EXT THK  
PER SAE AMS-QQ-N-290  
INSULATION - COLOR BLACK
- 5 NOTE DELETED
- 6 FOR  $0.813 [.032]$  TO  $2.083 [.082]$  WIRE INSULATION DIA.
- 7 NOTE DELETED
- 8 DIMENSION APPLIES FROM EDGE OF METAL  
WIRE BARREL TO CENTER OF STUD HOLE

1000	4.343 [.171]	M4 [#8]	LOOSE PIECE	50830-1
1000	3.683 [.145]	M3.5 [#6]	LOOSE PIECE	50830
QTY	"A"	"B"	PACKAGE TYPE	PART NO

AMP INCORPORATED CUSTOMER SERVICE SYSTEMS		MAX RECOMMENDED OPERATING TEMPERATURE: 288°C [550°F]	THIS DRAWING IS A CONTROLLED DOCUMENT.		DWN JR RUTH 11AUG03	<b>STE</b> TE Connectivity					
FOR ADDITIONAL PRODUCT INFORMATION OR COPIES OF DRAWINGS AND TECHNICAL DOCUMENTS	PRODUCT INFORMATION CENTER 1-800-522-6752	VOLTAGE RATING: 300V MAX	DIMENSIONS: mm [INCHES]	TOLERANCES UNLESS OTHERWISE SPECIFIED:	CHK T MICHELUTTI 12AUG03				NAME TERMINAL, RING TONGUE, STRATO-THERM, PIDG, WIRE SIZE: 26-24 AWG		
FOR APPLICATION TOOLING INFORMATION	TOOLING ASSISTANCE CENTER 1-800-722-1111	CIRCULAR MIL AREA: 0.12-0.24mm <sup>2</sup> [238-475] STRANDED WIRE ONLY		0 PLC ± - 1 PLC ± - 2 PLC ± - 3 PLC ± 0.127 [.005] 4 PLC ± - ANGLES ± -	APVD T MICHELUTTI 12AUG03	PRODUCT SPEC	APPLICATION SPEC	SIZE	CAGE CODE	DRAWING NO	RESTRICTED TO
FOR ORDER ENTRY	1-800-526-5142		MATERIAL 3	FINISH 4	114 - 2162	—	114 - 2162	A3	00779	C-50830	—
					CUSTOMER DRAWING	SCALE	8:1	SHEET	1 OF 1	REV	R1