



*digital dna*™ 

*MC68HC(9)12D60*

*Advance Information*

*M68HC12*  
*Microcontrollers*

*MC68HC912D60/D*  
*Rev. 4, 11/2003*

[WWW.MOTOROLA.COM/SEMICONDUCTORS](http://WWW.MOTOROLA.COM/SEMICONDUCTORS)



# 68HC912D60

## Advance Information — Rev 4.0

---

---

*Motorola reserves the right to make changes without further notice to any products herein. Motorola makes no warranty, representation or guarantee regarding the suitability of its products for any particular purpose, nor does Motorola assume any liability arising out of the application or use of any product or circuit, and specifically disclaims any and all liability, including without limitation consequential or incidental damages. "Typical" parameters which may be provided in Motorola data sheets and/or specifications can and do vary in different applications and actual performance may vary over time. All operating parameters, including "Typicals" must be validated for each customer application by customer's technical experts. Motorola does not convey any license under its patent rights nor the rights of others. Motorola products are not designed, intended, or authorized for use as components in systems intended for surgical implant into the body, or other applications intended to support or sustain life, or for any other application in which the failure of the Motorola product could create a situation where personal injury or death may occur. Should Buyer purchase or use Motorola products for any such unintended or unauthorized application, Buyer shall indemnify and hold Motorola and its officers, employees, subsidiaries, affiliates, and distributors harmless against all claims, costs, damages, and expenses, and reasonable attorney fees arising out of, directly or indirectly, any claim of personal injury or death associated with such unintended or unauthorized use, even if such claim alleges that Motorola was negligent regarding the design or manufacture of the part. Motorola, Inc. is an Equal Opportunity/Affirmative Action Employer.*



## List of Paragraphs

List of Paragraphs . . . . .	5
Table of Contents . . . . .	7
List of Tables . . . . .	15
List of Figures . . . . .	19
Section 1. General Description . . . . .	23
Section 2. Central Processing Unit . . . . .	31
Section 3. Pinout and Signal Descriptions . . . . .	37
Section 4. Registers . . . . .	63
Section 5. Operating Modes and Resource Mapping . . . . .	73
Section 6. Bus Control and Input/Output . . . . .	87
Section 7. Flash Memory . . . . .	99
Section 8. EEPROM Memory . . . . .	115
Section 9. Resets and Interrupts . . . . .	123
Section 10. ROM . . . . .	133
Section 11. I/O Ports with Key Wake-up . . . . .	135
Section 12. Clock Functions . . . . .	143
Section 13. Pulse Width Modulator . . . . .	181
Section 14. Enhanced Capture Timer . . . . .	197
Section 15. Multiple Serial Interface . . . . .	237
Section 16. Motorola Interconnect Bus . . . . .	263

<b>Section 17. MSCAN Controller</b> . . . . .	<b>277</b>
<b>Section 18. Analog-to-Digital Converter</b> . . . . .	<b>323</b>
<b>Section 19. Development Support</b> . . . . .	<b>337</b>
<b>Section 20. Electrical Specifications</b> . . . . .	<b>365</b>
<b>Section 21. Appendix: CGM Practical Aspects</b> . . . . .	<b>387</b>
<b>Section 22. Appendix: 68HC912D60A Flash EEPROM</b>	<b>399</b>
<b>Section 23. Appendix: 68HC912D60A EEPROM</b> . . . . .	<b>407</b>
<b>Glossary</b> . . . . .	<b>419</b>
<b>Revision History</b> . . . . .	<b>429</b>

## Table of Contents

### List of Paragraphs

### Table of Contents

### List of Tables

### List of Figures

#### Section 1. General Description

1.1	Contents .....	23
1.2	Introduction .....	23
1.3	Features .....	24
1.4	Ordering Information .....	27
1.5	68HC(9)12D60 Block Diagrams .....	29

#### Section 2. Central Processing Unit

2.1	Contents .....	31
2.2	Introduction .....	31
2.3	Programming Model .....	31
2.4	Data Types .....	33
2.5	Addressing Modes .....	33
2.6	Indexed Addressing Modes .....	35
2.7	Opcodes and Operands .....	36

## Section 3. Pinout and Signal Descriptions

3.1	Contents . . . . .	37
3.2	68HC(9)12D60 Pin Assignments in 112-pin QFP . . . . .	38
3.3	68HC(9)12D60 Pin Assignments in 80-pin QFP . . . . .	40
3.4	Power Supply Pins . . . . .	42
3.5	Signal Descriptions . . . . .	44
3.6	Port Signals . . . . .	53

## Section 4. Registers

4.1	Contents . . . . .	63
4.2	Register Block . . . . .	63

## Section 5. Operating Modes and Resource Mapping

5.1	Contents . . . . .	73
5.2	Introduction . . . . .	73
5.3	Operating Modes . . . . .	73
5.4	Background Debug Mode . . . . .	76
5.5	Internal Resource Mapping . . . . .	79
5.6	Memory Maps . . . . .	86

## Section 6. Bus Control and Input/Output

6.1	Contents . . . . .	87
6.2	Introduction . . . . .	87
6.3	Detecting Access Type from External Signals . . . . .	87
6.4	Registers . . . . .	88

## Section 7. Flash Memory

7.1	Contents . . . . .	99
-----	--------------------	----



7.2	Introduction . . . . .	99
7.3	Overview . . . . .	100
7.4	Flash EEPROM Control Block . . . . .	100
7.5	Flash EEPROM Arrays . . . . .	100
7.6	Flash EEPROM Registers . . . . .	101
7.7	Operation . . . . .	105
7.8	Programming the Flash EEPROM . . . . .	108
7.9	Erasing the Flash EEPROM . . . . .	111
7.10	Program/Erase Protection Interlocks . . . . .	113
7.11	Stop or Wait Mode . . . . .	113

## **Section 8. EEPROM Memory**

8.1	Contents . . . . .	115
8.2	Introduction . . . . .	115
8.3	Future EEPROM Support . . . . .	116
8.4	EEPROM Programmer's Model . . . . .	117
8.5	EEPROM Control Registers . . . . .	118

## **Section 9. Resets and Interrupts**

9.1	Contents . . . . .	123
9.2	Introduction . . . . .	123
9.3	Maskable interrupts . . . . .	124
9.4	Latching of Interrupts . . . . .	125
9.5	Interrupt Control and Priority Registers . . . . .	127
9.6	Resets . . . . .	128
9.7	Effects of Reset . . . . .	130
9.8	Register Stacking . . . . .	131

9.9	Customer Information . . . . .	132
-----	--------------------------------	-----

## Section 10. ROM

10.1	Contents . . . . .	133
10.2	Introduction . . . . .	133
10.3	ROM Array . . . . .	133

## Section 11. I/O Ports with Key Wake-up

11.1	Contents . . . . .	135
11.2	Introduction . . . . .	135
11.3	Key Wake-up and Port Registers . . . . .	136
11.4	Key Wake-Up Input Filter . . . . .	140

## Section 12. Clock Functions

12.1	Contents . . . . .	143
12.2	Introduction . . . . .	143
12.3	Clock Sources . . . . .	144
12.4	Phase-Locked Loop (PLL) . . . . .	145
12.5	Acquisition and Tracking Modes . . . . .	147
12.6	Limp-Home and Fast STOP Recovery modes . . . . .	149
12.7	System Clock Frequency formulas . . . . .	167
12.8	Clock Divider Chains . . . . .	168
12.9	Computer Operating Properly (COP) . . . . .	172
12.10	Real-Time Interrupt . . . . .	173
12.11	Clock Monitor . . . . .	173
12.12	Clock Function Registers . . . . .	174

## Section 13. Pulse Width Modulator

13.1	Contents . . . . .	181
13.2	Introduction . . . . .	181
13.3	PWM Register Description . . . . .	184
13.4	PWM Boundary Cases . . . . .	196

## **Section 14. Enhanced Capture Timer**

14.1	Contents . . . . .	197
14.2	Introduction . . . . .	197
14.3	Enhanced Capture Timer Modes of Operation . . . . .	203
14.4	Timer Registers . . . . .	207
14.5	Timer and Modulus Counter Operation in Different Modes . .	235

## **Section 15. Multiple Serial Interface**

15.1	Contents . . . . .	237
15.2	Introduction . . . . .	237
15.3	Block diagram . . . . .	238
15.4	Serial Communication Interface (SCI) . . . . .	238
15.5	Serial Peripheral Interface (SPI) . . . . .	250
15.6	Port S . . . . .	260

## **Section 16. Motorola Interconnect Bus**

16.1	Contents . . . . .	263
16.2	Introduction . . . . .	263
16.3	Push-pull sequence . . . . .	264
16.4	Biphase coding . . . . .	265
16.5	Message validation . . . . .	266
16.6	Interfacing to MI Bus . . . . .	268

16.7	MI Bus clock rate	270
16.8	SCI0/MI Bus registers	270

## Section 17. MSCAN Controller

17.1	Contents	277
17.2	Introduction	277
17.3	External Pins	278
17.4	Message Storage	279
17.5	Identifier Acceptance Filter	284
17.6	Interrupts	287
17.7	Protocol Violation Protection	289
17.8	Low Power Modes	290
17.9	Timer Link	294
17.10	Clock System	295
17.11	Memory Map	298
17.12	Programmer's Model of Message Storage	298
17.13	Programmer's Model of Control Registers	303

## Section 18. Analog-to-Digital Converter

18.1	Contents	323
18.2	Introduction	323
18.3	Functional Description	324
18.4	ATD Registers	325
18.5	ATD Mode Operation	336

## Section 19. Development Support

19.1	Contents	337
------	----------	-----

19.2	Introduction . . . . .	337
19.3	Instruction Queue . . . . .	337
19.4	Background Debug Mode . . . . .	339
19.5	Breakpoints . . . . .	355
19.6	Instruction Tagging . . . . .	362

## **Section 20. Electrical Specifications**

20.1	Contents . . . . .	365
20.2	Introduction . . . . .	365
20.3	Tables of Data . . . . .	366

## **Section 21. Appendix: CGM Practical Aspects**

21.1	Contents . . . . .	387
21.2	Introduction . . . . .	387
21.3	A Few Hints For The CGM Crystal Oscillator Application. . . . .	387
21.4	Practical Aspects For The PLL Usage . . . . .	390
21.5	Printed Circuit Board Guidelines . . . . .	395

## **Section 22. Appendix: 68HC912D60A Flash EEPROM**

22.1	Contents . . . . .	399
22.2	Introduction . . . . .	399
22.3	Overview . . . . .	400
22.4	Flash EEPROM Control Block . . . . .	400
22.5	Flash EEPROM Arrays . . . . .	400
22.6	Flash EEPROM Registers . . . . .	401
22.7	Operation . . . . .	403
22.8	Programming the Flash EEPROM . . . . .	404

22.9 Erasing the Flash EEPROM . . . . .	405
22.10 Stop or Wait Mode . . . . .	405

## **Section 23. Appendix: 68HC912D60A EEPROM**

23.1 Contents . . . . .	407
23.2 Introduction . . . . .	407
23.3 EEPROM Programmer's Model . . . . .	408
23.4 EEPROM Control Registers . . . . .	409
23.5 Program/Erase Operation . . . . .	415
23.6 Shadow Word Mapping . . . . .	415
23.7 Programming EEDIVH and EEDIVL Registers . . . . .	416

## **Glossary**

## **Revision History**

23.8 Changes from Rev 3.0 to Rev 4.0 . . . . .	429
23.9 Changes from Rev 2.0 to Rev 3.0 . . . . .	429
23.10 Changes from Rev 1.0 to Rev 2.0 . . . . .	430

## List of Tables

Table	Title	Page
1-1	Device Ordering Information . . . . .	27
1-2	68HC(9)12D60 Development Tools Ordering Information . . . . .	28
2-1	M68HC12 Addressing Mode Summary . . . . .	34
2-2	Summary of Indexed Operations . . . . .	35
3-1	68HC(9)12D60 Power and Ground Connection Summary . . . . .	44
3-2	68HC(9)12D60 Signal Description Summary . . . . .	51
3-3	68HC(9)12D60 Port Description Summary . . . . .	60
3-4	Port Pull-Up, Pull-Down and Reduced Drive Summary . . . . .	61
4-1	68HC(9)12D60 Register Map . . . . .	64
5-1	Mode Selection . . . . .	74
5-2	Mapping Precedence . . . . .	80
5-3	RFSTR Stretch Bit Definition . . . . .	85
5-4	EXSTR Stretch Bit Definition . . . . .	85
7-1	Effects of ENPE, LAT and ERAS on Array Reads . . . . .	105
8-1	1K byte EEPROM Block Protection . . . . .	120
8-2	Erase Selection . . . . .	121
9-1	Interrupt Vector Map . . . . .	126
9-2	Stacking Order on Entry to Interrupts . . . . .	132
12-1	Summary of STOP Mode Exit Conditions . . . . .	161
12-2	Summary of Pseudo STOP Mode Exit Conditions . . . . .	161
12-3	Clock Monitor Time-Outs . . . . .	173
12-4	Real Time Interrupt Rates . . . . .	175
12-5	COP Watchdog Rates . . . . .	178
13-1	Clock A and Clock B Prescaler . . . . .	186
13-2	PWM Left-Aligned Boundary Conditions . . . . .	196
13-3	PWM Center-Aligned Boundary Conditions . . . . .	196
14-1	Compare Result Output Action . . . . .	212
14-2	Edge Detector Circuit Configuration . . . . .	212
14-3	Prescaler Selection . . . . .	214

## List of Tables

15-1	Baud Rate Generation	240
15-2	Loop Mode Functions	243
15-3	SS Output Selection	253
15-4	SPI Clock Rate Selection	257
16-1	MI Bus Delay	275
17-1	msCAN12 Interrupt Vectors	289
17-2	msCAN12 vsCPU operating modes	291
17-3	CAN Standard Compliant Bit Time Segment Settings	297
17-4	Data length codes	302
17-5	Synchronization jump width	307
17-6	Baud rate prescaler	307
17-7	Time segment syntax	308
17-8	Time segment values	309
17-9	Identifier Acceptance Mode Settings	315
17-10	Identifier Acceptance Hit Indication	316
18-1	ATD Response to Background Debug Enable	327
18-2	Final Sample Time Selection	328
18-3	Clock Prescaler Values	329
18-4	Multichannel Mode Result Register Assignment	331
19-1	IPIPE Decoding	338
19-2	Hardware Commands	344
19-3	BDM Firmware Commands	345
19-4	BDM registers	347
19-5	TTAGO Decoding	352
19-6	TTAGO Value	352
19-7	Instruction	352
19-8	REGN Decoding	352
19-9	Breakpoint Mode Control	358
19-10	Breakpoint Address Range Control	359
19-11	Breakpoint Read/Write Control	361
19-12	Tag Pin Function	363
20-1	Maximum Ratings	366
20-2	Thermal Characteristics	367
20-3	DC Electrical Characteristics	368
20-4	Supply Current	369
20-5	ATD DC Electrical Characteristics	369
20-6	Analog Converter Characteristics (Operating)	370
20-7	ATD AC Characteristics (Operating)	371



20-8	ATD Maximum Ratings . . . . .	371
20-9	EEPROM Characteristics . . . . .	372
20-10	Flash EEPROM Characteristics (68HC912D60 only) . . . . .	372
20-11	Pulse Width Modulator Characteristics . . . . .	374
20-12	Control Timing . . . . .	374
20-13	Peripheral Port Timing . . . . .	380
20-14	Multiplexed Expansion Bus Timing . . . . .	381
20-15	SPI Timing . . . . .	383
20-16	CGM Characteristics . . . . .	386
20-17	Key Wake-up . . . . .	386
20-18	msCAN12 Wake-up Time from Sleep Mode . . . . .	386
21-1	Suggested 8MHz Synthesis PLL Filter Elements (Tracking Mode) . . . . .	393
21-2	Suggested 8MHz Synthesis PLL Filter Elements (Acquisition Mode) . . . . .	394
23-1	EEDIV Selection . . . . .	410
23-2	2K byte EEPROM Block Protection . . . . .	412
23-3	Erase Selection . . . . .	413
23-4	Shadow word mapping . . . . .	415

## List of Tables

## List of Figures

Figure	Title	Page
1-1	68HC(9)12D60 112-pin QFP Block Diagram . . . . .	29
1-2	68HC(9)12D60 80-pin QFP Block Diagram . . . . .	30
2-1	Programming Model . . . . .	32
3-1	Pin Assignments in 112-pin TQFP for 68HC(9)12D60 . . . . .	38
3-2	112-pin TQFP Mechanical Dimensions (case no987) . . . . .	39
3-3	Pin Assignments in 80-pin QFP for 68HC(9)12D60 . . . . .	40
3-4	80-pin QFP Mechanical Dimensions (case no841B) . . . . .	41
3-5	PLL Loop Filter Connections . . . . .	43
3-6	Common Crystal Connections . . . . .	45
3-7	External Oscillator Connections . . . . .	45
5-1	68HC(9)12D60 Memory Map . . . . .	86
6-1	Access Type vs Bus Control Pins . . . . .	88
7-1	Program Sequence Flow . . . . .	110
7-2	Erase Sequence Flow. . . . .	112
11-1	STOP Key Wake-up Filter (falling edge trigger) timing. . . . .	141
12-1	Internal Clock Relationships . . . . .	145
12-2	PLL Functional Diagram . . . . .	146
12-3	Clock Loss during Normal Operation . . . . .	150
12-4	No Clock at Power-On Reset . . . . .	152
12-5	STOP Exit and Fast STOP Recovery . . . . .	155
12-6	Clock Generation Chain . . . . .	169
12-7	Clock Chain for SCI0, SCI1, RTI, COP. . . . .	170
12-8	Clock Chain for ECT. . . . .	171
12-9	Clock Chain for MSCAN, SPI, ATD0, ATD1 and BDM. . . . .	172
13-1	Block Diagram of PWM Left-Aligned Output Channel . . . . .	182
13-2	Block Diagram of PWM Center-Aligned Output Channel . . . . .	183
13-3	PWM Clock Sources. . . . .	184
14-1	Timer Block Diagram in Latch Mode. . . . .	199
14-2	Timer Block Diagram in Queue Mode. . . . .	200

## List of Figures

14-3	8-Bit Pulse Accumulators Block Diagram . . . . .	201
14-4	16-Bit Pulse Accumulators Block Diagram . . . . .	202
14-5	Block Diagram for Port7 with Output compare / Pulse Accumulator A . . . . .	203
14-6	C3F-C0F Interrupt Flag Setting . . . . .	203
15-1	Multiple Serial Interface Block Diagram . . . . .	238
15-2	Serial Communications Interface Block Diagram . . . . .	239
15-3	Serial Peripheral Interface Block Diagram . . . . .	251
15-4	SPI Clock Format 0 (CPHA = 0) . . . . .	252
15-5	SPI Clock Format 1 (CPHA = 1) . . . . .	253
15-6	Normal Mode and Bidirectional Mode. . . . .	254
16-1	MI Bus timing . . . . .	264
16-2	Biphase coding and error detection . . . . .	266
16-3	MI BUS Block Diagram . . . . .	267
16-4	A typical MI Bus interface . . . . .	269
17-1	The CAN System . . . . .	279
17-2	User Model for Message Buffer Organization. . . . .	282
17-3	32-bit Maskable Identifier Acceptance Filters . . . . .	286
17-4	16-bit Maskable Acceptance Filters . . . . .	286
17-5	8-bit Maskable Acceptance Filters . . . . .	287
17-6	SLEEP Request / Acknowledge Cycle . . . . .	293
17-7	Clocking Scheme . . . . .	295
17-8	Segments within the Bit Time . . . . .	297
17-9	msCAN12 Memory Map . . . . .	298
17-10	Message Buffer Organization . . . . .	299
17-11	Receive/Transmit Message Buffer Extended Identifier. . . . .	300
17-12	Standard Identifier Mapping . . . . .	301
18-1	Analog-to-Digital Converter Block Diagram . . . . .	324
19-1	BDM Host to Target Serial Bit Timing. . . . .	341
19-2	BDM Target to Host Serial Bit Timing (Logic 1) . . . . .	341
19-3	BDM Target to Host Serial Bit Timing (Logic 0) . . . . .	342
20-1	V <sub>FP</sub> Conditioning Circuit . . . . .	373
20-2	V <sub>FP</sub> Operating Range . . . . .	373
20-3	Timer Inputs . . . . .	375
20-4	POR and External Reset Timing Diagram . . . . .	376
20-5	STOP Recovery Timing Diagram . . . . .	377
20-6	WAIT Recovery Timing Diagram . . . . .	378
20-7	Interrupt Timing Diagram . . . . .	379

20-8	Port Read Timing Diagram . . . . .	380
20-9	Port Write Timing Diagram . . . . .	380
20-10	Multiplexed Expansion Bus Timing Diagram . . . . .	382
20-11	SPI Timing Diagram (1 of 2) . . . . .	384
20-12	SPI Timing Diagram (2 of 2) . . . . .	385

# List of Figures

## Section 1. General Description

### 1.1 Contents

1.2	Introduction . . . . .	23
1.3	Features . . . . .	24
1.4	Ordering Information . . . . .	27
1.5	68HC(9)12D60 Block Diagrams . . . . .	29

### 1.2 Introduction

The 68HC(9)12D60 microcontroller unit (MCU) is a 16-bit device available in two package options, 80-pin QFP and 112-pin TQFP. On-chip peripherals include a 16-bit central processing unit (CPU12), 60K bytes of flash EEPROM (68HC912D60) or ROM (68HC12D60), 2K bytes of RAM, 1K bytes of EEPROM, two asynchronous serial communication interfaces (SCI), a serial peripheral interface (SPI), an enhanced capture timer (ECT), two (one on 80QFP) 8-channel, 10-bit analog-to-digital converters (ATD), a four-channel pulse-width modulator (PWM), and a CAN 2.0 A, B software compatible module (MSCAN12). System resource mapping, clock generation, interrupt control and bus interfacing are managed by the lite integration module (LIM). The 68HC(9)12D60 has full 16-bit data paths throughout, however, the external bus can operate in an 8-bit narrow mode so single 8-bit wide memory can be interfaced for lower cost systems. The inclusion of a PLL circuit allows power consumption and performance to be adjusted to suit operational requirements. In addition to the I/O ports available in each module, 16 (2 on 80QFP) I/O port pins are available with Key-Wake-Up capability from STOP or WAIT mode.

## 1.3 Features

- 16-bit CPU12
  - Upward compatible with M68HC11 instruction set
  - Interrupt stacking and programmer's model identical to M68HC11
  - 20-bit ALU
  - Instruction queue
  - Enhanced indexed addressing
- Multiplexed bus
  - Single chip or expanded
  - 16 address/16 data wide or 16 address/8 data narrow mode
- Two 8-bit ports with key wake-up interrupt (2 pins only are available on 80QFP) and one I<sup>2</sup>C start bit detector (112TQFP only)
- Memory
  - 60K byte flash EEPROM, made of a 28K module and a 32K module with 8K bytes protected BOOT section in each module (68HC912D60)
  - 60K byte ROM (68HC12D60)
  - 1K byte EEPROM
  - 2K byte RAM
- Analog-to-digital converters
  - 2 x 8-channels, 10-bit resolution in 112TQFP
  - 1 x 8-channels, 8-bit resolution in 80QFP
- 1M bit per second, CAN 2.0 A, B software compatible module
  - Two receive and three transmit buffers
  - Flexible identifier filter programmable as 2 x 32 bit, 4 x 16 bit or 8 x 8 bit
  - Four separate interrupt channels for Rx, Tx, error and wake-up



- Low-pass filter wake-up function
- In 80QFP, only TxCAN and RxCAN pins are available
- Loop-back for self test operation
- Programmable link to a timer input capture channel, for time-stamping and network synchronization.
- Enhanced capture timer (ECT)
  - 16-bit main counter with 7-bit prescaler
  - 8 programmable input capture or output compare channels; 4 of the 8 input captures with buffer
  - Input capture filters and buffers, three successive captures on four channels, or two captures on four channels with a capture/compare selectable on the remaining four
  - Four 8-bit or two 16-bit pulse accumulators
  - 16-bit modulus down-counter with 4-bit prescaler
  - Four user-selectable delay counters for signal filtering
- 4 PWM channels with programmable period and duty cycle
  - 8-bit 4-channel or 16-bit 2-channel
  - Separate control for each pulse width and duty cycle
  - Center- or left-aligned outputs
  - Programmable clock select logic with a wide range of frequencies
- Serial interfaces
  - Two asynchronous serial communications interfaces (SCI)
  - MI-Bus implemented on final devices
  - Synchronous serial peripheral interface (SPI)
- LIM (light integration module)
  - WCR (windowed COP watchdog, real time interrupt, clock monitor)
  - ROC (reset and clocks)

## General Description

- MEBI (multiplexed external bus interface)
- MBI (internal bus interface and map)
- INT (interrupt control)
- Clock generation
  - Phase-locked loop clock frequency multiplier
  - Limp home mode in absence of external clock
  - Slow mode divider
  - Low power 0.5 to 16 MHz crystal oscillator reference clock
- 112-Pin TQFP package or 80-pin QFP package
  - Up to 68 general-purpose I/O lines, plus up to 18 input-only lines in 112TQFP
  - or
  - Up to 48 general-purpose I/O lines, plus up to 10 input-only lines in 80QFP
- 8MHz operation at 5V
- Development support
  - Single-wire background debug™ mode (BDM)
  - On-chip hardware breakpoints

## 1.4 Ordering Information

**Table 1-1. Device Ordering Information**

Package	Temperature		Voltage	Frequency	Order Number
	Range	Designator			
112-Pin TQFP Single Tray 60 Pcs	0 to +70°C		4.5V–5.5V	8 MHz	XC68HC912D60PV8
	–40 to +85°C	C			XC68HC912D60CPV8
	–40 to +105°C	V			XC68HC912D60VPV8
	–40 to +125°C	M*			XC68HC912D60MPV8
80-Pin QFP Single Tray 84 Pcs	0 to +70°C		4.5V–5.5V	8 MHz	XC68HC912D60FU8
	–40 to +85°C	C			XC68HC912D60CFU8
	–40 to +105°C	V			XC68HC912D60VFU8
	–40 to +125°C	M*			XC68HC912D60MFU8
112-Pin TQFP Single Tray 60 Pcs	0 to +70°C		4.5V–5.5V	8 MHz	XC68HC12D60PV8
	–40 to +85°C	C			XC68HC12D60CPV8
	–40 to +105°C	V			XC68HC12D60VPV8
	–40 to +125°C	M*			XC68HC12D60MPV8
80-Pin QFP Single Tray 84 Pcs	0 to +70°C		4.5V–5.5V	8 MHz	XC68HC12D60FU8
	–40 to +85°C	C			XC68HC12D60CFU8
	–40 to +105°C	V			XC68HC12D60VFU8
	–40 to +125°C	M*			XC68HC12D60MFU8

\* **Important:** M temperature operation is available only for **single chip modes**

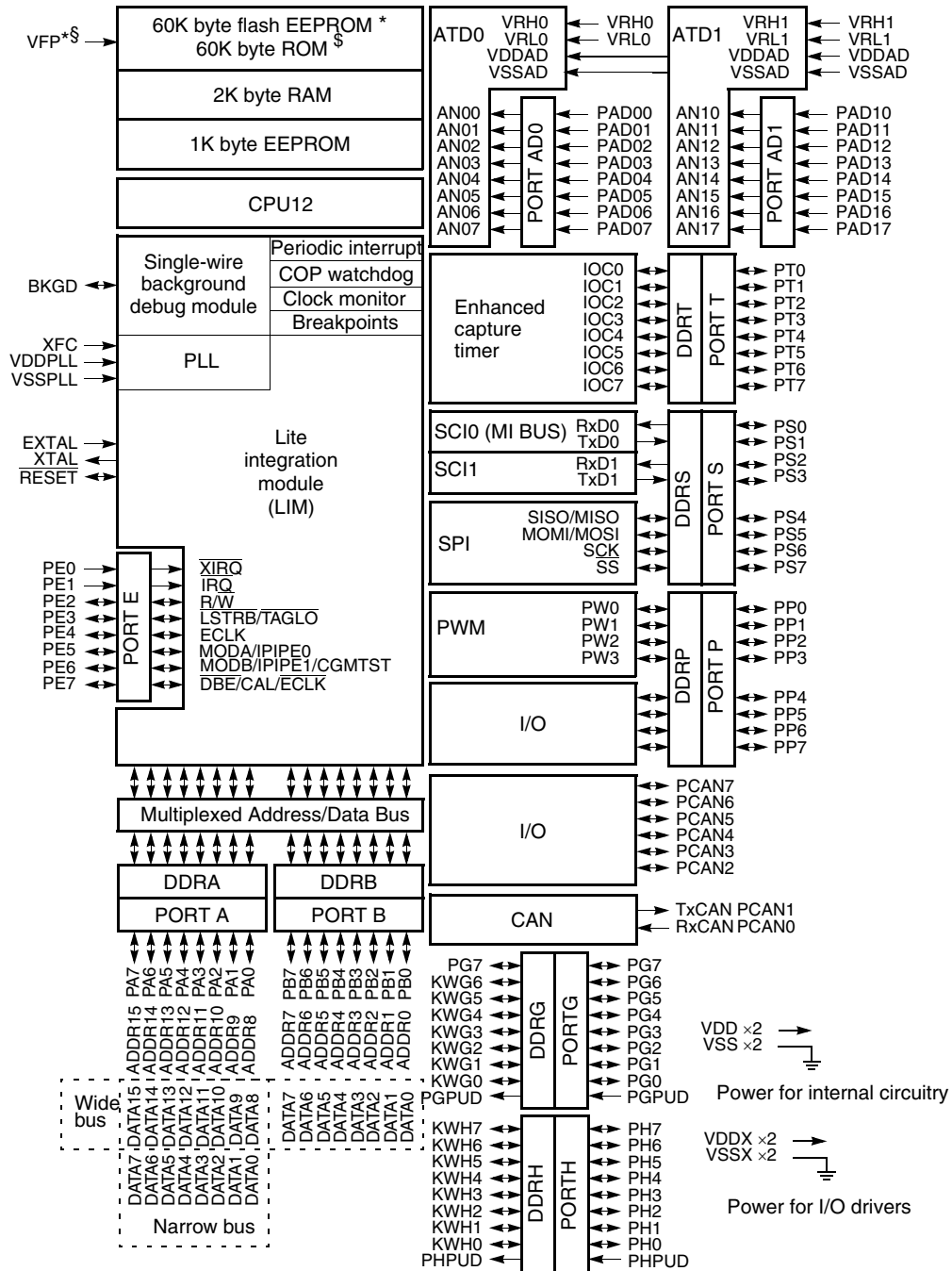
**Table 1-2. 68HC(9)12D60 Development Tools Ordering Information**

Description	Name	Order Number
MCUez		Free from World Wide Web
Serial Debug Interface	SDI	M68SDIL (3–5V), M68DIL12 (SDIL + MCUez + SDEBUG12)
Evaluation board	EVB	M68EVB912D60 (EVB only) M68KIT912D60 (EVB + SDIL12)

**NOTE:** *SDEBUG12 is a P & E Micro Product. It can be obtained from P & E from their web site (<http://www.pemicro.com>) for approximately \$100.*

Third party tools: [http://www.mcu.motsps.com/dev\\_tools/3rd/index.html](http://www.mcu.motsps.com/dev_tools/3rd/index.html)

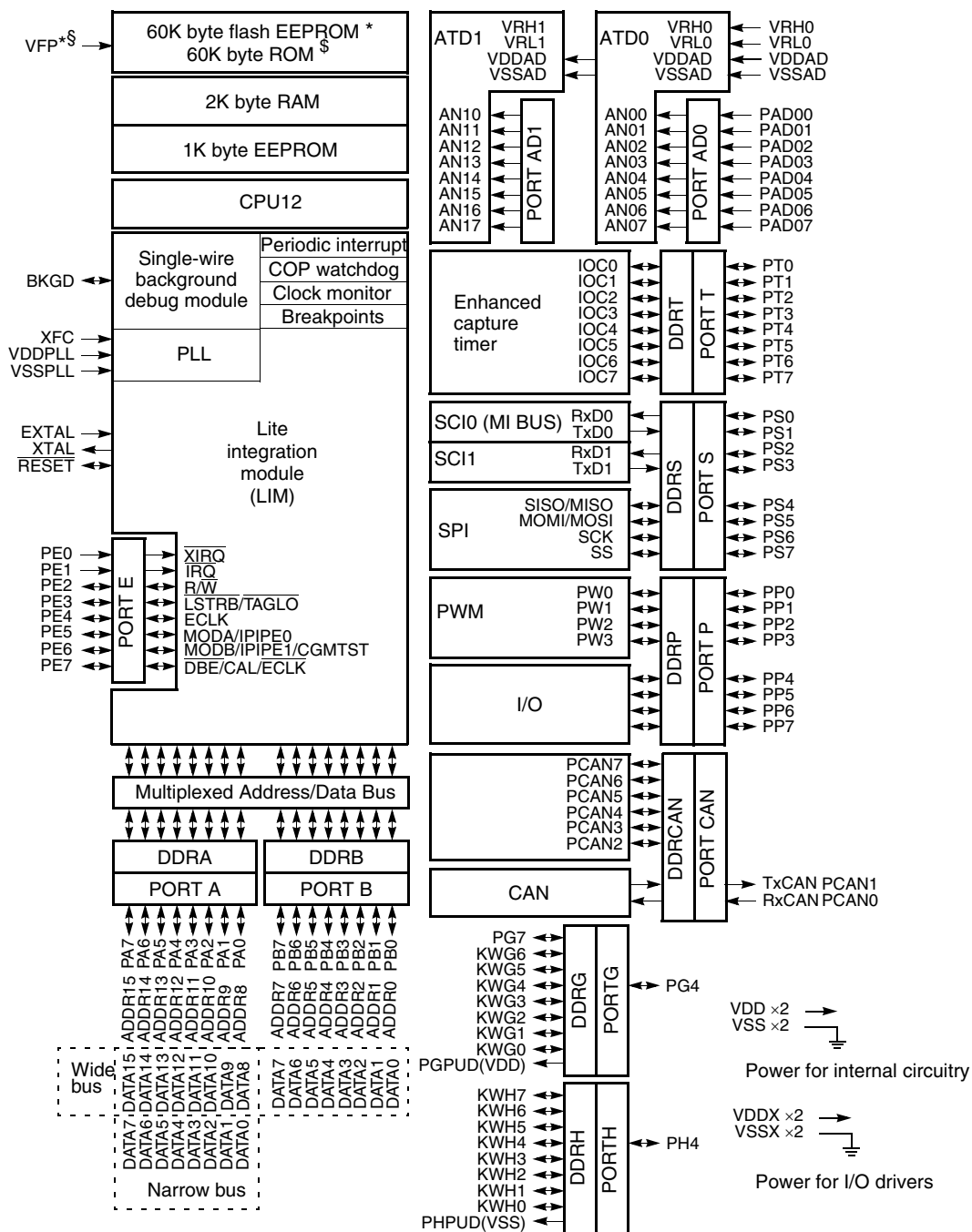
## 1.5 68HC(9)12D60 Block Diagrams



**Notes:** \* 68HC912D60 only  
 \$ 68HC12D60 only  
 § On the 68HC12D60 this pin is not connected and can be tied to 5V or 12V without effect.

**Figure 1-1. 68HC(9)12D60 112-pin QFP Block Diagram**

# General Description



**Notes:** \* 68HC912D60 only  
 \$ 68HC12D60 only  
 § On the 68HC12D60 this pin is not connected and can be tied to 5V or 12V without effect.

Several I/O on ports G, H and CAN are unavailable externally on the 80-pin QFP package. These internal pins should either be defined as outputs or have their pull-ups/downs enabled.

**Figure 1-2. 68HC(9)12D60 80-pin QFP Block Diagram**

## Section 2. Central Processing Unit

### 2.1 Contents

2.2	Introduction . . . . .	31
2.3	Programming Model . . . . .	31
2.4	Data Types . . . . .	33
2.5	Addressing Modes . . . . .	33
2.6	Indexed Addressing Modes . . . . .	35
2.7	Opcodes and Operands . . . . .	36

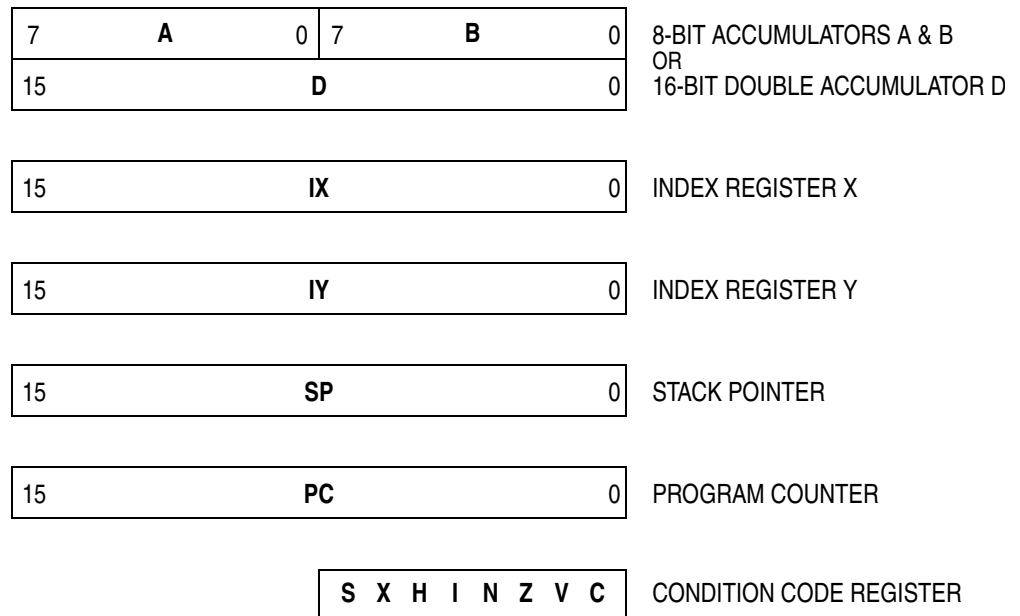
### 2.2 Introduction

The CPU12 is a high-speed, 16-bit processing unit. It has full 16-bit data paths and wider internal registers (up to 20 bits) for high-speed extended math instructions. The instruction set is a proper superset of the M68HC11 instruction set. The CPU12 allows instructions with odd byte counts, including many single-byte instructions. This provides efficient use of ROM space. An instruction queue buffers program information so the CPU always has immediate access to at least three bytes of machine code at the start of every instruction. The CPU12 also offers an extensive set of indexed addressing capabilities.

### 2.3 Programming Model

CPU12 registers are an integral part of the CPU and are not addressed as if they were memory locations.

# Central Processing Unit



**Figure 2-1. Programming Model**

**Accumulators** A and B are general-purpose 8-bit accumulators used to hold operands and results of arithmetic calculations or data manipulations. Some instructions treat the combination of these two 8-bit accumulators as a 16-bit double accumulator (accumulator D).

**Index registers** X and Y are used for indexed addressing mode. In the indexed addressing mode, the contents of a 16-bit index register are added to 5-bit, 9-bit, or 16-bit constants or the content of an accumulator to form the effective address of the operand to be used in the instruction.

**Stack pointer** (SP) points to the last stack location used. The CPU12 supports an automatic program stack that is used to save system context during subroutine calls and interrupts, and can also be used for temporary storage of data. The stack pointer can also be used in all indexed addressing modes.

**Program counter** is a 16-bit register that holds the address of the next instruction to be executed. The program counter can be used in all indexed addressing modes except autoincrement/decrement.



**Condition Code Register (CCR)** contains five status indicators, two interrupt masking bits, and a STOP disable bit. The five flags are half carry (H), negative (N), zero (Z), overflow (V), and carry/borrow (C). The half-carry flag is used only for BCD arithmetic operations. The N, Z, V, and C status bits allow for branching based on the results of a previous operation.

After a reset, the CPU fetches a vector from the appropriate address and begins executing instructions. The X and I interrupt mask bits are set to mask any interrupt requests. The S bit is also set to inhibit the STOP instruction.

## 2.4 Data Types

The CPU12 supports the following data types:

- Bit data
- 8-bit and 16-bit signed and unsigned integers
- 16-bit unsigned fractions
- 16-bit addresses

A byte is eight bits wide and can be accessed at any byte location. A word is composed of two consecutive bytes with the most significant byte at the lower value address. There are no special requirements for alignment of instructions or operands.

## 2.5 Addressing Modes

Addressing modes determine how the CPU accesses memory locations to be operated upon. The CPU12 includes all of the addressing modes of the M68HC11 CPU as well as several new forms of indexed addressing. [Table 2-1](#) is a summary of the available addressing modes.

**Table 2-1. M68HC12 Addressing Mode Summary**

Addressing Mode	Source Format	Abbreviation	Description
Inherent	<b>INST</b> (no externally supplied operands)	INH	Operands (if any) are in CPU registers
Immediate	<b>INST #opr8i</b> or <b>INST #opr16i</b>	IMM	Operand is included in instruction stream 8- or 16-bit size implied by context
Direct	<b>INST opr8a</b>	DIR	Operand is the lower 8-bits of an address in the range \$0000 – \$00FF
Extended	<b>INST opr16a</b>	EXT	Operand is a 16-bit address
Relative	<b>INST rel8</b> or <b>INST rel16</b>	REL	An 8-bit or 16-bit relative offset from the current pc is supplied in the instruction
Indexed (5-bit offset)	<b>INST oprx5,xysp</b>	IDX	5-bit signed constant offset from x, y, sp, or pc
Indexed (auto pre-decrement)	<b>INST oprx3,-xys</b>	IDX	Auto pre-decrement x, y, or sp by 1 ~ 8
Indexed (auto pre-increment)	<b>INST oprx3,+xys</b>	IDX	Auto pre-increment x, y, or sp by 1 ~ 8
Indexed (auto post-decrement)	<b>INST oprx3,xys-</b>	IDX	Auto post-decrement x, y, or sp by 1 ~ 8
Indexed (auto post-increment)	<b>INST oprx3,xys+</b>	IDX	Auto post-increment x, y, or sp by 1 ~ 8
Indexed (accumulator offset)	<b>INST abd,xysp</b>	IDX	Indexed with 8-bit (A or B) or 16-bit (D) accumulator offset from x, y, sp, or pc
Indexed (9-bit offset)	<b>INST oprx9,xysp</b>	IDX1	9-bit signed constant offset from x, y, sp, or pc (lower 8-bits of offset in one extension byte)
Indexed (16-bit offset)	<b>INST oprx16,xysp</b>	IDX2	16-bit constant offset from x, y, sp, or pc (16-bit offset in two extension bytes)
Indexed-Indirect (16-bit offset)	<b>INST [opr16,xysp]</b>	[IDX2]	Pointer to operand is found at... 16-bit constant offset from x, y, sp, or pc (16-bit offset in two extension bytes)
Indexed-Indirect (D accumulator offset)	<b>INST [D,xysp]</b>	[D,IDX]	Pointer to operand is found at... x, y, sp, or pc plus the value in D

## 2.6 Indexed Addressing Modes

The CPU12 indexed modes reduce execution time and eliminate code size penalties for using the Y index register. CPU12 indexed addressing uses a postbyte plus zero, one, or two extension bytes after the instruction opcode. The postbyte and extensions do the following tasks:

- Specify which index register is used.
- Determine whether a value in an accumulator is used as an offset.
- Enable automatic pre- or post-increment or decrement
- Specify use of 5-bit, 9-bit, or 16-bit signed offsets.

**Table 2-2. Summary of Indexed Operations**

Postbyte Code (xb)	Source Code Syntax	Comments
rr0nnnnn	,r n,r -n,r	<b>5-bit constant offset</b> n = -16 to +15 rr can specify X, Y, SP, or PC
111rr0zs	n,r -n,r	<b>Constant offset</b> (9- or 16-bit signed) z=0 = 9-bit with sign in LSB of postbyte(s) 1 = 16-bit if z = s = 1, 16-bit offset indexed-indirect (see below) rr can specify X, Y, SP, or PC
111rr011	[n,r]	<b>16-bit offset indexed-indirect</b> rr can specify X, Y, SP, or PC
rr1pnrrr	n,-r n,+r n,r- n,r+	<b>Auto pre-decrement/increment or Auto post-decrement/increment;</b> p = pre-(0) or post-(1), n = -8 to -1, +1 to +8 rr can specify X, Y, or SP (PC not a valid choice)
111rr1aa	A,r B,r D,r	<b>Accumulator offset</b> (unsigned 8-bit or 16-bit) aa-00 = A 01 = B 10 = D (16-bit) 11 = see accumulator D offset indexed-indirect rr can specify X, Y, SP, or PC
111rr111	[D,r]	<b>Accumulator D offset indexed-indirect</b> rr can specify X, Y, SP, or PC

## 2.7 Opcodes and Operands

The CPU12 uses 8-bit opcodes. Each opcode identifies a particular instruction and associated addressing mode to the CPU. Several opcodes are required to provide each instruction with a range of addressing capabilities.

Only 256 opcodes would be available if the range of values were restricted to the number that can be represented by 8-bit binary numbers. To expand the number of opcodes, a second page is added to the opcode map. Opcodes on the second page are preceded by an additional byte with the value \$18.

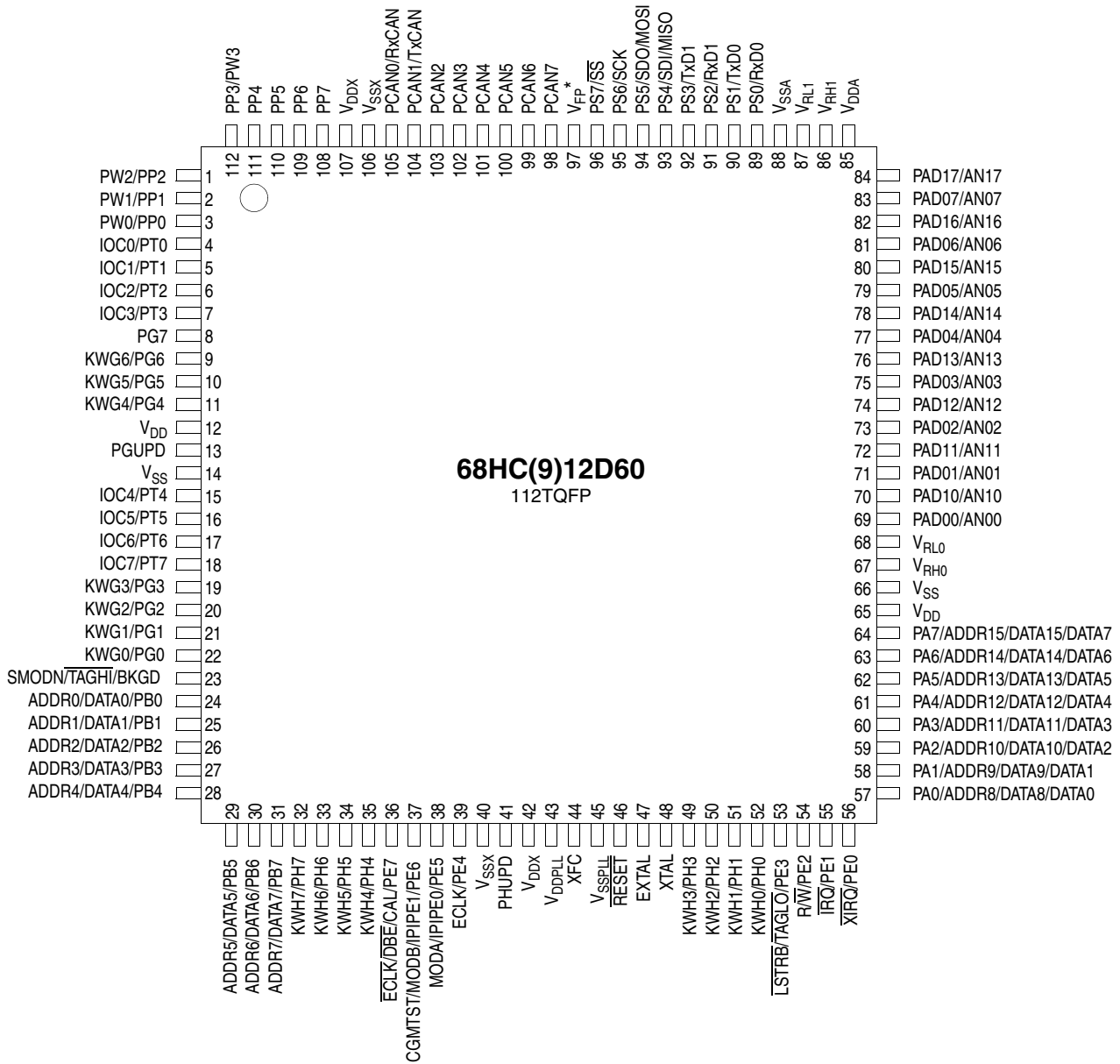
To provide additional addressing flexibility, opcodes can also be followed by a postbyte or extension bytes. Postbytes implement certain forms of indexed addressing, transfers, exchanges, and loop primitives. Extension bytes contain additional program information such as addresses, offsets, and immediate data.

## Section 3. Pinout and Signal Descriptions

### 3.1 Contents

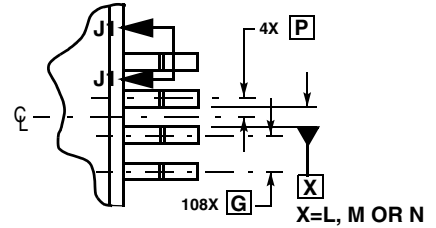
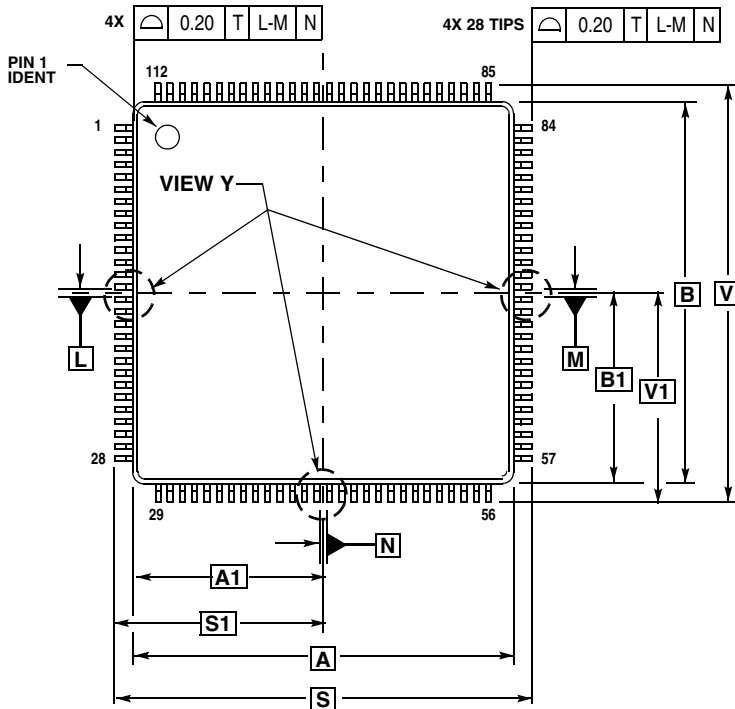
3.2	68HC(9)12D60 Pin Assignments in 112-pin QFP. . . . .	38
3.3	68HC(9)12D60 Pin Assignments in 80-pin QFP. . . . .	40
3.4	Power Supply Pins . . . . .	42
3.5	Signal Descriptions. . . . .	44
3.6	Port Signals . . . . .	53

## 3.2 68HC(9)12D60 Pin Assignments in 112-pin QFP

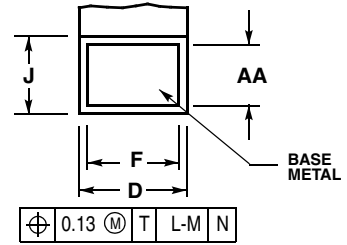


**Figure 3-1. Pin Assignments in 112-pin TQFP for 68HC(9)12D60**

\* Available on 68HC912D60 only. On the 68HC12D60 this pin is not connected and can be tied to 5V or 12V without effect.



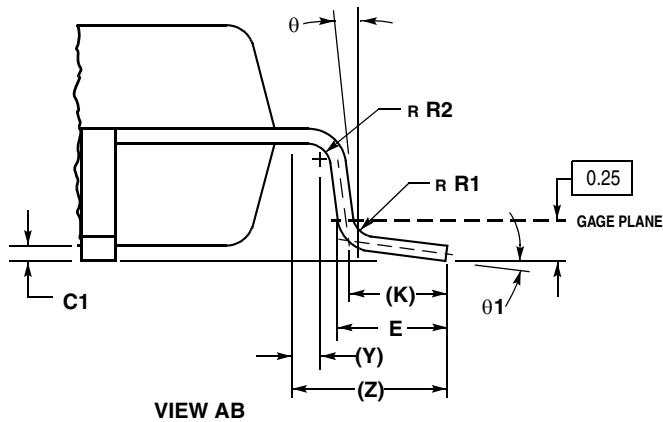
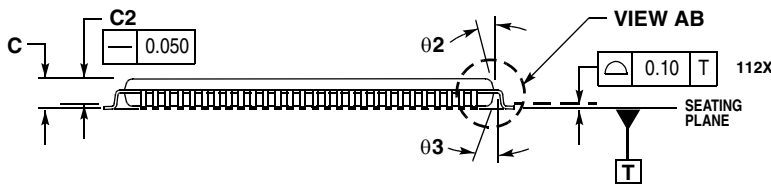
VIEW Y



SECTION J1-J1  
ROTATED 90° COUNTERCLOCKWISE

NOTES:

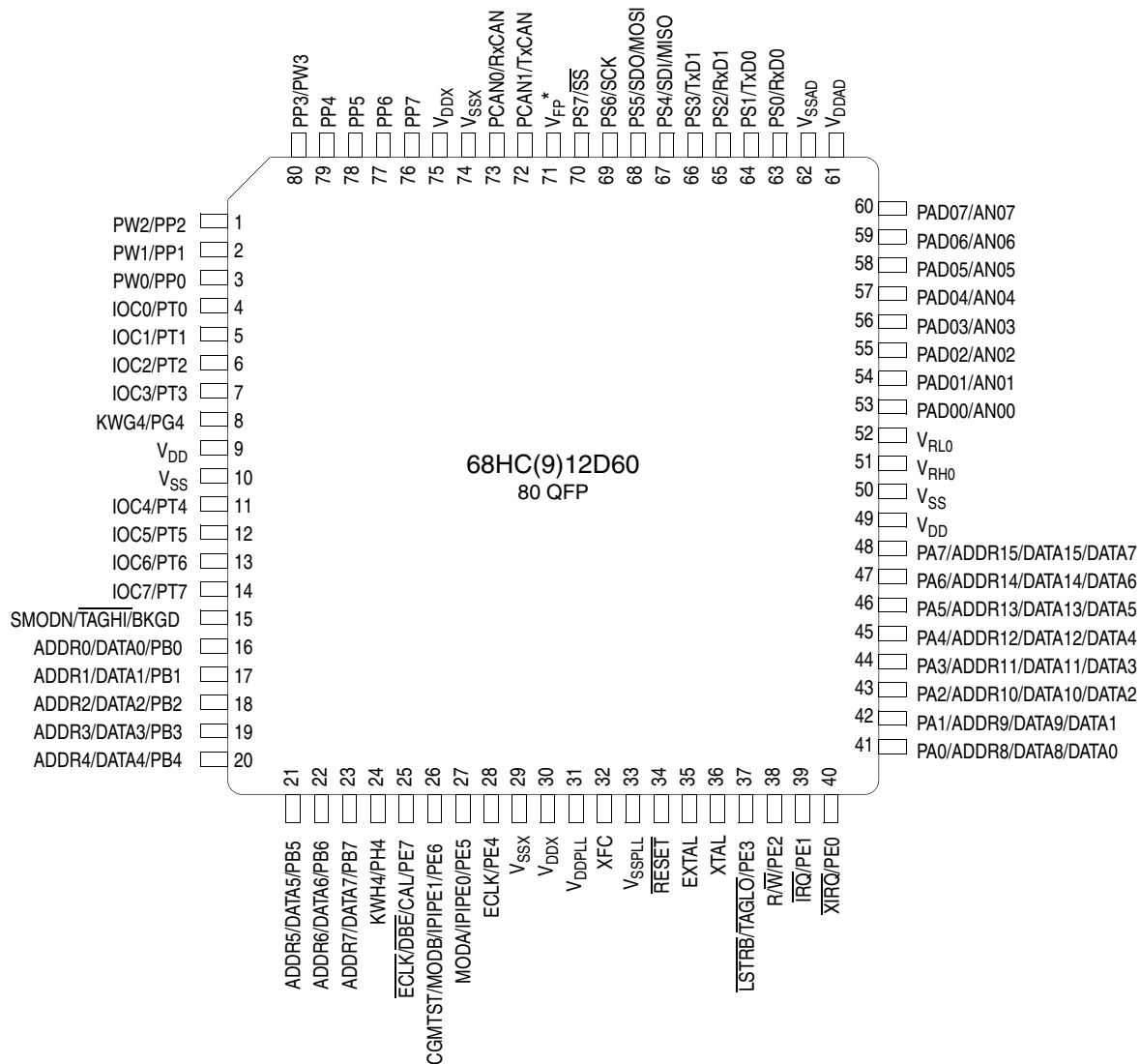
1. DIMENSIONING AND TOLERANCING PER ASME Y14.5M, 1994.
2. DIMENSIONS IN MILLIMETERS.
3. DATUMS L, M AND N TO BE DETERMINED AT SEATING PLANE, DATUM T.
4. DIMENSIONS S AND V TO BE DETERMINED AT SEATING PLANE, DATUM T.
5. DIMENSIONS A AND B DO NOT INCLUDE MOLD PROTRUSION. ALLOWABLE PROTRUSION IS 0.25 PER SIDE. DIMENSIONS A AND B INCLUDE MOLD MISMATCH.
6. DIMENSION D DOES NOT INCLUDE DAMBAR PROTRUSION. ALLOWABLE DAMBAR PROTRUSION SHALL NOT CAUSE THE D DIMENSION TO EXCEED 0.46.



MILLIMETERS		
DIM	MIN	MAX
A	20.000	BSC
A1	10.000	BSC
B	20.000	BSC
B1	10.000	BSC
C	---	1.600
C1	0.050	0.150
C2	1.350	1.450
D	0.270	0.370
E	0.450	0.750
F	0.270	0.330
G	0.650	BSC
J	0.090	0.170
K	0.500	REF
P	0.325	BSC
R1	0.100	0.200
R2	0.100	0.200
S	22.000	BSC
S1	11.000	BSC
V	22.000	BSC
V1	11.000	BSC
Y	0.250	REF
Z	1.000	REF
AA	0.090	0.160
theta	0°	8°
theta 1	3°	7°
theta 2	11°	13°
theta 3	11°	13°

Figure 3-2. 112-pin TQFP Mechanical Dimensions (case no. 987)

## 3.3 68HC(9)12D60 Pin Assignments in 80-pin QFP



**Figure 3-3. Pin Assignments in 80-pin QFP for 68HC(9)12D60**

\* Available on 68HC912D60 only. On the 68HC12D60 this pin is not connected and can be tied to 5V or 12V without effect.



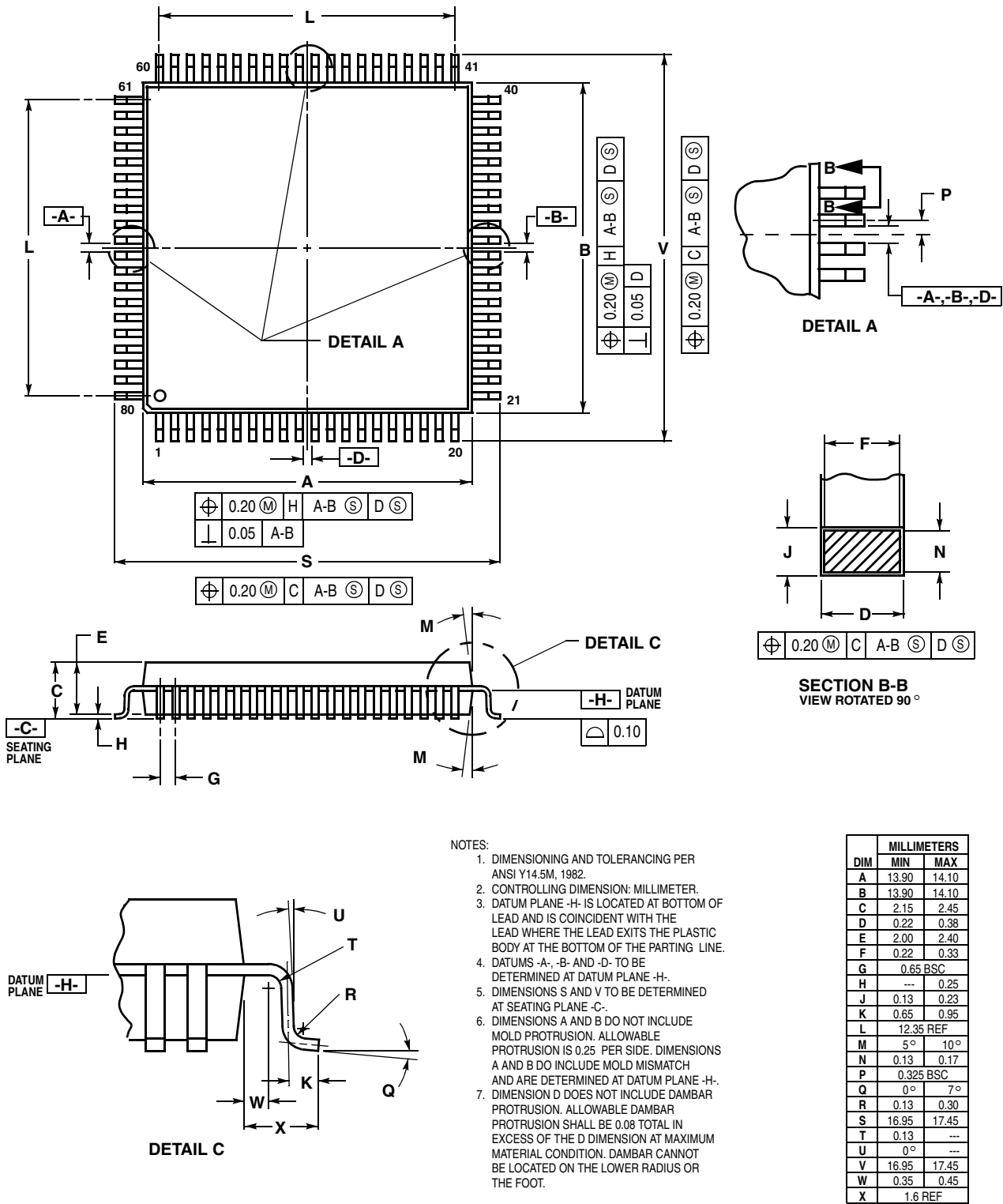


Figure 3-4. 80-pin QFP Mechanical Dimensions (case no. 841B)

### 3.4 Power Supply Pins

68HC(9)12D60 power and ground pins are described below and summarized in [Table 3-1](#).

#### 3.4.1 Internal Power ( $V_{DD}$ ) and Ground ( $V_{SS}$ )

Power is supplied to the MCU through  $V_{DD}$  and  $V_{SS}$ . Because fast signal transitions place high, short-duration current demands on the power supply, use bypass capacitors with high-frequency characteristics and place them as close to the MCU as possible. Bypass requirements depend on how heavily the MCU pins are loaded.

#### 3.4.2 External Power ( $V_{DDX}$ ) and Ground ( $V_{SSX}$ )

External power and ground for I/O drivers. Because fast signal transitions place high, short-duration current demands on the power supply, use bypass capacitors with high-frequency characteristics and place them as close to the MCU as possible. Bypass requirements depend on how heavily the MCU pins are loaded.

#### 3.4.3 $V_{DDA}$ , $V_{SSA}$

Provides operating voltage and ground for the analog-to-digital converter. This allows the supply voltage to the ATD to be bypassed independently. Connecting  $V_{DDA}$  to  $V_{DD}$  if the ATD modules are not used will not result in an increase of power consumption.

#### 3.4.4 Analog to Digital Reference Voltages ( $V_{RH}$ , $V_{RL}$ )

$V_{RH0}$ ,  $V_{RL0}$ : reference voltage high and low for ATD converter 0.

$V_{RH1}$ ,  $V_{RL1}$ : reference voltage high and low for ATD converter 1.

If the ATD modules are not used, leaving  $V_{RH}$  connected to  $V_{DD}$  will not result in an increase of power consumption.

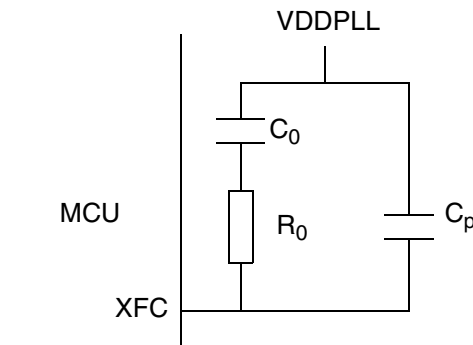
### 3.4.5 $V_{DDPLL}$ , $V_{SSPLL}$

Provides operating voltage and ground for the Phased-Locked Loop. This allows the supply voltage to the PLL to be bypassed independently.

**NOTE:** *The  $V_{SSPLL}$  pin should always be grounded even if the PLL is not used. The  $V_{DDPLL}$  pin should not be left floating. It is recommended to connect the  $V_{DDPLL}$  pin to ground if the PLL is not used.*

### 3.4.6 XFC

PLL loop filter. Please see [Appendix: CGM Practical Aspects](#) for information on how to calculate PLL loop filter elements. Any current leakage on this pin must be avoided.



**Figure 3-5. PLL Loop Filter Connections**

If  $V_{DDPLL}$  is connected to  $V_{SS}$  (this is normal case), then the XFC pin should either be left floating or connected to  $V_{SS}$  (**never** to  $V_{DD}$ ). If  $V_{DDPLL}$  is tied to  $V_{DD}$  but the PLL is switched off (PLLON bit cleared), then the XFC pin should be connected preferably to  $V_{DDPLL}$  (i.e. ready for VCO minimum frequency).

### 3.4.7 $V_{FP}$

Flash EEPROM programming voltage and supply voltage during normal operation (68HC912D60 only – on the 68HC12D60 this pin is not connected and can be tied to 5V or 12V without effect).

**Table 3-1. 68HC(9)12D60 Power and Ground Connection Summary**

Mnemonic	Pin Number		Description
	80-pin QFP	112-pin QFP	
$V_{DD}$	9, 49	12, 65	Internal power and ground.
$V_{SS}$	10, 50	14, 66	
$V_{DDX}$	30, 75	42, 107	External power and ground, supply to pin drivers.
$V_{SSX}$	29, 74	40, 106	
$V_{DDA}$	61	85	Operating voltage and ground for the analog-to-digital converter, allows the supply voltage to the A/D to be bypassed independently.
$V_{SSA}$	62	88	
$V_{RH1}$	—	86	Reference voltages for the analog-to-digital converter 1
$V_{RL1}$	—	87	
$V_{RH0}$	51	67	Reference voltages for the analog-to-digital converter 0.
$V_{RL0}$	52	68	
$V_{DDPLL}$	31	43	Provides operating voltage and ground for the Phased-Locked Loop. This allows the supply voltage to the PLL to be bypassed independently.
$V_{SSPLL}$	33	45	
$V_{FP}$	71	97	Programming voltage for the Flash EEPROM and required supply for normal operation. (68HC912D60 only – on the 68HC12D60 this pin is not connected and can be tied to 5V or 12V without effect)

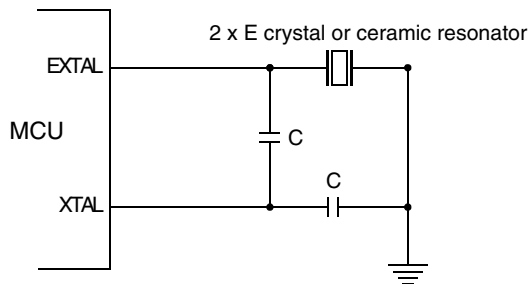
## 3.5 Signal Descriptions

### 3.5.1 Crystal Driver and External Clock Input (XTAL, EXTAL)

These pins provide the interface for either a crystal or a CMOS compatible clock to control the internal clock generator circuitry. Out of reset the frequency applied to EXTAL is twice the desired E-clock rate. All the device clocks are derived from the EXTAL input frequency.

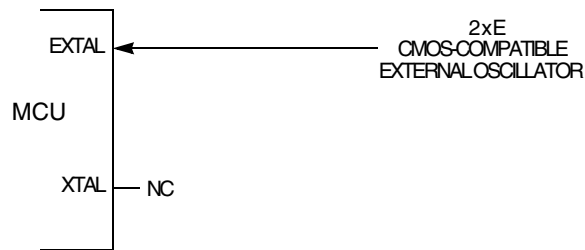
**NOTE:** *CRYSTAL CIRCUIT IS CHANGED FROM STANDARD.*

**NOTE:** The internal return path for the oscillator is the VSSPLL pin. Therefore it is recommended to connect the common node of the resonator and the capacitor directly to the VSSPLL pin.



**Figure 3-6. Common Crystal Connections**

**NOTE:** When selecting a crystal, it is recommended to use one with the lowest possible frequency in order to minimise EMC emissions.



**Figure 3-7. External Oscillator Connections**

XTAL is the crystal output. The XTAL pin must be left unterminated when an external CMOS compatible clock input is connected to the EXTAL pin. The XTAL output is normally intended to drive only a crystal. The XTAL output can be buffered with a high-impedance buffer to drive the EXTAL input of another device.

In all cases take extra care in the circuit board layout around the oscillator pins. Load capacitances in the oscillator circuits include all stray layout capacitances. Refer to [Figure 3-6](#) and [Figure 3-7](#) for diagrams of oscillator circuits.

### 3.5.2 E-Clock Output (ECLK)

ECLK is the output connection for the internal bus clock and is used to demultiplex the address and data and is used as a timing reference. ECLK frequency is equal to 1/2 the crystal frequency out of reset. The E-clock output is turned off in single chip user mode to reduce the effects of RFI. It can be turned on if necessary. In single-chip special mode, the E-clock is turned ON at reset and can be turned OFF. In special peripheral mode the E-clock is an input to the MCU. All clocks, including the E clock, are halted when the MCU is in STOP mode. It is possible to configure the MCU to interface to slow external memory. ECLK can be stretched for such accesses.

### 3.5.3 Reset ( $\overline{\text{RESET}}$ )

An active low bidirectional control signal,  $\overline{\text{RESET}}$ , acts as an input to initialize the MCU to a known start-up state. It also acts as an open-drain output to indicate that an internal failure has been detected in either the clock monitor or COP watchdog circuit. The MCU goes into reset asynchronously and comes out of reset synchronously. This allows the part to reach a proper reset state even if the clocks have failed, while allowing synchronized operation when starting out of reset.

It is important to use an external low-voltage reset circuit (such as MC34064 or MC34164) to prevent corruption of RAM or EEPROM due to power transitions.

The reset sequence is initiated by any of the following events:

- Power-on-reset (POR)
- COP watchdog enabled and watchdog timer times out
- Clock monitor enabled and Clock monitor detects slow or stopped clock
- User applies a low level to the reset pin

External circuitry connected to the reset pin should not include a large capacitance that would interfere with the ability of this signal to rise to a valid logic one within nine bus cycles after the low drive is released.

Upon detection of any reset, an internal circuit drives the reset pin low and a clocked reset sequence controls when the MCU can begin normal processing. In the case of POR or a clock monitor error, a 4096 cycle oscillator startup delay is imposed before the reset recovery sequence starts (reset is driven low throughout this 4096 cycle delay). The internal reset recovery sequence then drives reset low for 16 to 17 cycles and releases the drive to allow reset to rise. Nine cycles later this circuit samples the reset pin to see if it has risen to a logic one level. If reset is low at this point, the reset is assumed to be coming from an external request and the internally latched states of the COP timeout and clock monitor failure are cleared so the normal reset vector (\$FFFE:FFFF) is taken when reset is finally released. If reset is high after this nine cycle delay, the reset source is tentatively assumed to be either a COP failure or a clock monitor fail. If the internally latched state of the clock monitor fail circuit is true, processing begins by fetching the clock monitor vector (\$FFFC:FFFD). If no clock monitor failure is indicated, and the latched state of the COP timeout is true, processing begins by fetching the COP vector (\$FFFA:FFFB). If neither clock monitor fail nor COP timeout are pending, processing begins by fetching the normal reset vector (\$FFFE:FFFF).

### 3.5.4 Maskable Interrupt Request ( $\overline{\text{IRQ}}$ )

The  $\overline{\text{IRQ}}$  input provides a means of applying asynchronous interrupt requests to the MCU. Either falling edge-sensitive triggering or level-sensitive triggering is program selectable (INTCR register).  $\overline{\text{IRQ}}$  is always enabled and configured to level-sensitive triggering at reset. It can be disabled by clearing the IRQEN bit (INTCR register). When the MCU is reset the  $\overline{\text{IRQ}}$  function is masked in the condition code register.

This pin is always an input and can always be read. There is an active pull-up on this pin while in reset and immediately out of reset. The pull-up can be turned off by clearing PUPE in the PUCR register.

### 3.5.5 Nonmaskable Interrupt ( $\overline{XIRQ}$ )

The  $\overline{XIRQ}$  input provides a means of requesting a nonmaskable interrupt after reset initialization. During reset, the X bit in the condition code register (CCR) is set and any interrupt is masked until MCU software enables it. Because the  $\overline{XIRQ}$  input is level sensitive, it can be connected to a multiple-source wired-OR network. This pin is always an input and can always be read. There is an active pull-up on this pin while in reset and immediately out of reset. The pull-up can be turned off by clearing PUPE in the PUCR register.  $\overline{XIRQ}$  is often used as a power loss detect interrupt.

Whenever  $\overline{XIRQ}$  or  $\overline{IRQ}$  are used with multiple interrupt sources ( $\overline{IRQ}$  must be configured for level-sensitive operation if there is more than one source of  $\overline{IRQ}$  interrupt), each source must drive the interrupt input with an open-drain type of driver to avoid contention between outputs. There must also be an interlock mechanism at each interrupt source so that the source holds the interrupt line low until the MCU recognizes and acknowledges the interrupt request. If the interrupt line is held low, the MCU will recognize another interrupt as soon as the interrupt mask bit in the MCU is cleared (normally upon return from an interrupt).

### 3.5.6 Mode Select (SMODN, MODA, and MODB)

The state of these pins during reset determine the MCU operating mode. After reset, MODA and MODB can be configured as instruction queue tracking signals IPIPE0 and IPIPE1. MODA and MODB have active pull-downs during reset.

The SMODN pin has an active pull-up when configured as input. This pin can be used as BKGD or  $\overline{TAGHI}$  after reset.

### 3.5.7 Single-Wire Background Mode Pin (BKGD)

The BKGD pin receives and transmits serial background debugging commands. A special self-timing protocol is used. The BKGD pin has an active pull-up when configured as input; BKGD has no pull-up control. Refer to [Development Support](#).



### 3.5.8 External Address and Data Buses (ADDR[15:0] and DATA[15:0])

External bus pins share function with general-purpose I/O ports A and B. In single-chip operating modes, the pins can be used for I/O; in expanded modes, the pins are used for the external buses.

In expanded wide mode, ports A and B are used for multiplexed 16-bit data and address buses. PA[7:0] correspond to ADDR[15:8]/DATA[15:8]; PB[7:0] correspond to ADDR[7:0]/DATA[7:0].

In expanded narrow mode, ports A and B are used for the 16-bit address bus, and an 8-bit data bus is multiplexed with the most significant half of the address bus on port A. In this mode, 16-bit data is handled as two back-to-back bus cycles, one for the high byte followed by one for the low byte. PA[7:0] correspond to ADDR[15:8] and to DATA[15:8] or DATA[7:0], depending on the bus cycle. The state of the address pin should be latched at the rising edge of E. To allow for maximum address setup time at external devices, a transparent latch should be used.

### 3.5.9 Read/Write ( $\overline{R/W}$ )

In all modes this pin can be used as general-purpose I/O and is an input with an active pull-up out of reset. If the read/write function is required it should be enabled by setting the RDWE bit in the PEAR register. External writes will not be possible until enabled.

### 3.5.10 Low-Byte Strobe ( $\overline{LSTRB}$ )

In all modes this pin can be used as general-purpose I/O and is an input with an active pull-up out of reset. If the strobe function is required, it should be enabled by setting the LSTRE bit in the PEAR register. This signal is used in write operations and so external low byte writes will not be possible until this function is enabled. This pin is also used as  $\overline{TAGLO}$  in Special Expanded modes and is multiplexed with the  $\overline{LSTRB}$  function.

### 3.5.11 Instruction Queue Tracking Signals (IPIPE1 and IPIPE0)

These signals are used to track the state of the internal instruction execution queue. Execution state is time-multiplexed on the two signals. Refer to [Development Support](#).

### 3.5.12 Data Bus Enable ( $\overline{\text{DBE}}$ )

The  $\overline{\text{DBE}}$  pin (PE7) is an active low signal that will be asserted low during E-clock high time.  $\overline{\text{DBE}}$  provides separation between output of a multiplexed address and the input of data. When an external address is stretched,  $\overline{\text{DBE}}$  is asserted during what would be the last quarter cycle of the last E-clock cycle of stretch. In expanded modes this pin is used to enable the drive control of external buses during external reads. Use of the  $\overline{\text{DBE}}$  is controlled by the NDBE bit in the PEAR register.  $\overline{\text{DBE}}$  is enabled out of reset in expanded modes. This pin has an active pull-up during and after reset in single chip modes.

### 3.5.13 Inverted E clock ( $\overline{\text{ECLK}}$ )

The  $\overline{\text{ECLK}}$  pin (PE7) can be used to latch the address for de-multiplexing. It has the same behavior as the ECLK, except is inverted. In expanded modes this pin is used to enable the drive control of external buses during external reads. Use of the  $\overline{\text{ECLK}}$  is controlled by the NDBE and DBENE bits in the PEAR register.

### 3.5.14 Calibration reference (CAL)

The CAL pin (PE7) is the output of the Slow Mode programmable clock divider, SLWCLK, and is used as a calibration reference. The SLWCLK frequency is equal to the crystal frequency out of reset and always has a 50% duty. If the  $\overline{\text{DBE}}$  function is enabled it will override the enabled CAL output. The CAL pin output is disabled by clearing CALE bit in the PEAR register.

### 3.5.15 Clock generation module test (CGMTST)

The CGMTST pin (PE6) is the output of the clocks tested when CGMTE bit is set in PEAR register. The PIPOE bit must be cleared for the clocks to be tested.

**Table 3-2. 68HC(9)12D60 Signal Description Summary**

Pin Name	Pin Number		Description
	80-pin	112-pin	
EXTAL	35	47	Crystal driver and external clock input pins. On reset all the device clocks are derived from the EXTAL input frequency. XTAL is the crystal output.
XTAL	36	48	
$\overline{\text{RESET}}$	34	46	An active low bidirectional control signal, $\overline{\text{RESET}}$ acts as an input to initialize the MCU to a known start-up state, and an output when COP or clock monitor causes a reset.
ADDR[7:0] DATA[7:0]	23–16	31–24	External bus pins share function with general-purpose I/O ports A and B. In single chip modes, the pins can be used for I/O. In expanded modes, the pins are used for the external buses.
ADDR[15:8] DATA[15:8]	48–41	64–57	
$\overline{\text{DBE}}$	25	36	Data bus control and, in expanded mode, enables the drive control of external buses during external reads.
$\overline{\text{ECLK}}$	25	36	Inverted E clock used to latch the address.
CAL	25	36	CAL is the output of the Slow Mode programmable clock divider, SLWCLK, and is used as a calibration reference for functions such as time of day. It is overridden when DBE function is enabled. It always has a 50% duty cycle.
CGMTST	26	37	Clock generation module test output.
MODB/ IPIPE1, MODA/ IPIPE0	26, 27	37, 38	State of mode select pins during reset determine the initial operating mode of the MCU. After reset, MODB and MODA can be configured as instruction queue tracking signals IPIPE1 and IPIPE0 or as general-purpose I/O pins.
ECLK	28	39	E Clock is the output connection for the external bus clock. ECLK is used as a timing reference and for address demultiplexing.
$\overline{\text{LSTRB}}$ / $\overline{\text{TAGLO}}$	37	53	Low byte strobe (0 = low byte valid), in all modes this pin can be used as I/O. The low strobe function is the exclusive-NOR of A0 and the internal $\overline{\text{SZ8}}$ signal. (The $\overline{\text{SZ8}}$ internal signal indicates the size 16/8 access.) Pin function $\overline{\text{TAGLO}}$ used in instruction tagging. See <a href="#">Development Support</a> .
R/ $\overline{\text{W}}$	38	54	Indicates direction of data on expansion bus. Shares function with general-purpose I/O. Read/write in expanded modes.
$\overline{\text{IRQ}}$	39	55	Maskable interrupt request input provides a means of applying asynchronous interrupt requests to the MCU. Either falling edge-sensitive triggering or level-sensitive triggering is program selectable (INTCR register).

**Table 3-2. 68HC(9)12D60 Signal Description Summary**

Pin Name	Pin Number		Description
	80-pin	112-pin	
$\overline{\text{XIRQ}}$	40	56	Provides a means of requesting asynchronous nonmaskable interrupt requests after reset initialization
SMODN/BK GD/ $\overline{\text{TAGHI}}$	15	23	Single-wire background interface pin is dedicated to the background debug function. During reset, this pin determines special or normal operating mode. Pin function $\overline{\text{TAGHI}}$ used in instruction tagging. See <a href="#">Development Support</a> .
PW[3:0]	80, 1–3	112, 1–3	Pulse Width Modulator channel outputs.
$\overline{\text{SS}}$	70	96	Slave select output for SPI master mode, input for slave mode or master mode.
SCK	69	95	Serial clock for SPI system.
SDO/MOSI	68	94	Master out/slave in pin for serial peripheral interface
SDI/MISO	67	93	Master in/slave out pin for serial peripheral interface
TxD1	66	92	SCI1 transmit pin
RxD1	65	91	SCI1 receive pin
TxD0	64	90	SCI0 transmit pin
RxD0	63	89	SCI0 receive pin
IOC[7:0]	14–11, 7–4	18–15, 7–4	Pins used for input capture and output compare in the timer and pulse accumulator subsystem.
AN1[7:0]	N/A	84/82/80/78/ 76/74/72/70	Analog inputs for the analog-to-digital conversion module 1
AN0[7:0]	60–53	83/81/79/77/ 75/73/71/69	Analog inputs for the analog-to-digital conversion module 0
TxCAN	72	104	MSCAN transmit pin
RxCAN	73	105	MSCAN receive pin
KWG[6:0]	8 (KWG4 only)	9–11, 19–22	Key wake-up and general purpose I/O; can cause an interrupt when an input transitions from high to low. On 80-pin QFP all 8 I/O should be initialised.
PGUPD	(1)	13	Defines if I/O port resistive load is a pull-up or a pull-down, when enabled.
KWH[7:0]	24 (KWH4 only)	32–35, 49–52	Key wake-up and general purpose I/O; can cause an interrupt when an input transitions from high to low. On 80-pin QFP all 8 I/O should be initialised.
PHUPD	(2)	41	Defines if I/O port resistive load is a pull-up or a pull-down, when enabled.

1. In the 80-pin version PGUPD is connected internally to VDD

2. In the 80-pin version PHUPD is connected internally to VSS

## 3.6 Port Signals

The 68HC(9)12D60 incorporates eight ports which are used to control and access the various device subsystems. When not used for these purposes, port pins may be used for general-purpose I/O. In addition to the pins described below, each port consists of a data register which can be read and written at any time, and, with the exception of port AD0, port AD1 (available only in 112TQFP), PE[1:0], RxCAN and TxCAN, a data direction register which controls the direction of each pin. After reset all general purpose I/O pins are configured as input.

### 3.6.1 Port A

Port A pins are used for address and data in expanded modes. In single chip modes, the pins can be used as I/O. The port data register is not in the address map during expanded and peripheral mode operation. When it is in the map, port A can be read or written at anytime.

Register DDRA determines whether each port A pin is an input or output. DDRA is not in the address map during expanded and peripheral mode operation. Setting a bit in DDRA makes the corresponding bit in port A an output; clearing a bit in DDRA makes the corresponding bit in port A an input. The default reset state of DDRA is all zeros.

When the PUPA bit in the PUCR register is set, all port A input pins are pulled-up internally by an active pull-up device. This bit has no effect if the port is being used in expanded modes as the pull-ups are inactive.

Setting the RDPA bit in register RDRIV causes all port A outputs to have reduced drive level. RDRIV can be written once after reset. RDRIV is not in the address map in peripheral mode. Refer to [Bus Control and Input/Output](#).

### 3.6.2 Port B

Port B pins are used for address and data in expanded modes. In single chip modes, the pins can be used as I/O. The port data register is not in the address map during expanded and peripheral mode operation. When it is in the map, port B can be read or written at anytime.

Register DDRB determines whether each port B pin is an input or output. DDRB is not in the address map during expanded and peripheral mode operation. Setting a bit in DDRB makes the corresponding bit in port B an output; clearing a bit in DDRB makes the corresponding bit in port B an input. The default reset state of DDRB is all zeros.

When the PUPB bit in the PUCR register is set, all port B input pins are pulled-up internally by an active pull-up device. This bit has no effect if the port is being used in expanded modes as the pull-ups are inactive.

Setting the RDPB bit in register RDRIV causes all port B outputs to have reduced drive level. RDRIV can be written once after reset. RDRIV is not in the address map in peripheral mode. Refer to [Bus Control and Input/Output](#).

### 3.6.3 Port E

Port E pins operate differently from port A and B pins. Port E pins are used for bus control signals and interrupt service request signals. When a pin is not used for one of these specific functions, it can be used as general-purpose I/O. However, two of the pins (PE[1:0]) can only be used for input, and the states of these pins can be read in the port data register even when they are used for  $\overline{\text{IRQ}}$  and  $\overline{\text{XIRQ}}$ .

The PEAR register determines pin function, and register DDRE determines whether each pin is an input or output when it is used for general-purpose I/O. PEAR settings override DDRE settings. Because PE[1:0] are input-only pins, only DDRE[7:2] have effect. Setting a bit in the DDRE register makes the corresponding bit in port E an output; clearing a bit in the DDRE register makes the corresponding bit in port E an input. The default reset state of DDRE is all zeros.

When the PUPE bit in the PUCR register is set, PE7 and PE[3:0] are pulled up by active devices.

Neither port E nor DDRE is in the map in peripheral mode; neither is in the internal map in expanded modes with EME set.

Setting the RDPE bit in register RDRIV causes all port E outputs to have reduced drive level. RDRIV can be written once after reset. RDRIV is not in the address map in peripheral mode. Refer to [Bus Control and Input/Output](#).

### 3.6.4 Port G

Port G pins are used for key wake-ups that can be used with the pins configured as inputs or outputs. The key wake-ups are triggered with a falling edge signal (KWPG). An interrupt is generated if the corresponding bit is enabled (KWIEG). If any of the interrupts is not enabled, the corresponding pin can be used as a general purpose I/O pin. Refer to [I/O Ports with Key Wake-up](#).

Register DDRG determines pin direction of port G when used for general-purpose I/O. When DDRG bits are set, the corresponding pin is configured for output. On reset the DDRG bits are cleared and the corresponding pin is configured for input.

Port PGUPD determines what type of resistive load is used for port G input pins when PUPG bit is set in the PUCR register. When PGUPD pin is low, it loads a pull-down in all port G input pins. When PGUPD pin is high, it loads a pull-up in all port G input pins.

In 80-pin version, the PGUPD is connected internally to VDD. The PG4 will have a pull-up. All port G pins should either be defined as outputs or have their pull-ups enabled.

Setting the RDPG bit in register RDRIV causes all port G outputs to have reduced drive level. RDRIV can be written once after reset. RDRIV is not in the address map in peripheral mode. Refer to [Bus Control and Input/Output](#).

### 3.6.5 Port H

Port H pins are used for key wake-ups that can be used with the pins configured as inputs or outputs. The key wake-ups are triggered with a falling edge signal (KWPH). An interrupt is generated if the corresponding bit is enabled (KWIEH). If any of the interrupts is not enabled, the corresponding pin can be used as a general purpose I/O pin. Refer to [I/O Ports with Key Wake-up](#).

Register DDRH determines pin direction of Port H when used for general-purpose I/O. When DDRH bits are set, the corresponding pin is configured for output. On reset the DDRH bits are cleared and the corresponding pin is configured for input.

Port PHUPD determines what type of resistive load is used for Port H input pins when PUPH bit is set in the PUCR register. When PHUPD pin is low, it loads a pull-down in all Port H input pins. When PHUPD pin is high, it loads a pull-up in all Port H input pins.

In 80-pin version, the PHUPD is connected internally to VSS. The PH4 will have a pull-down. All port H pins should either be defined as outputs or have their pull-downs enabled.

Setting the RDPH bit in register RDRIV causes all Port H outputs to have reduced drive level. RDRIV can be written once after reset. RDRIV is not in the address map in peripheral mode. Refer to [Bus Control and Input/Output](#).

### 3.6.6 Port CAN

The MSCAN12 uses two external pins, one input (RxCAN) and one output (TxCAN). The TxCAN output pin represents the logic level on the CAN: '0' is for a dominant state, and '1' is for a recessive state.

RxCAN is on bit 0 of Port CAN, TxCAN is on bit 1. The remaining six pins of Port CAN, available only in the 112-pin package, are controlled by registers in the MSCAN12 address space.

In 80QFP all PortCAN[2:7] pins should either be defined as outputs or have their pull-ups enabled.



### 3.6.7 Port AD1

Input to the analog-to-digital subsystem and general-purpose input. When analog-to-digital functions are not enabled, the port has eight general-purpose input pins, PAD1[7:0]. The ADPU bit in the ATD1CTL2 register enables the A/D function.

Port AD1 pins are inputs; no data direction register is associated with this port. The port has no resistive input loads and no reduced drive controls. Refer to [Analog-to-Digital Converter](#).

Port AD1 is not available in the 80-pin package.

### 3.6.8 Port AD0

Input to the analog-to-digital subsystem and general-purpose input. When analog-to-digital functions are not enabled, the port has eight general-purpose input pins, PAD0[7:0]. The ADPU bit in the ATD0CTL2 register enables the A/D function.

Port AD0 pins are inputs; no data direction register is associated with this port. The port has no resistive input loads and no reduced drive controls. Refer to [Analog-to-Digital Converter](#).

### 3.6.9 Port P

The four pulse-width modulation channel outputs share general-purpose port P pins. The PWM function is enabled with the PWEN register. Enabling PWM pins takes precedence over the general-purpose port. When pulse-width modulation is not in use, the port pins may be used for general-purpose I/O.

Register DDRP determines pin direction of port P when used for general-purpose I/O. When DDRP bits are set, the corresponding pin is configured for output. On reset the DDRP bits are cleared and the corresponding pin is configured for input.

When the PUPP bit in the PWCTL register is set, all input pins are pulled up internally by an active pull-up device. Pull-ups are disabled after reset.

Setting the RDPP bit in the PWCTL register configures all port P outputs to have reduced drive levels. Levels are at normal drive capability after reset. The PWCTL register can be read or written anytime after reset. Refer to [Pulse Width Modulator](#).

### 3.6.10 Port S

Port S is the 8-bit interface to the standard serial interface consisting of the two serial communications interfaces (SCI1 and SCI0) and the serial peripheral interface (SPI) subsystems. Port S pins are available for general-purpose parallel I/O when standard serial functions are not enabled.

Port S pins serve several functions depending on the various internal control registers. If WOMS bit in the SC0CR1 register is set, the P-channel drivers of the output buffers are disabled for bits 0 through 1 for the SCI1 (2 through 3 for the SCI0). If SWOM bit in the SP0CR1 register is set, the P-channel drivers of the output buffers are disabled for bits 4 through 7 (wire-ORed mode). The open drain control effects to both the serial and the general-purpose outputs. If the RDPSx bits in the PURDS register are set, the appropriate Port S pin drive capabilities are reduced. If PUPSx bits in the PURDS register are set, the appropriate pull-up device is connected to each port S pin which is programmed as a general-purpose input. If the pin is programmed as a general-purpose output, the pull-up is disconnected from the pin regardless of the state of the individual PUPSx bits. See [Multiple Serial Interface](#).

### 3.6.11 Port T

This port provides eight general-purpose I/O pins when not enabled for input capture and output compare in the timer and pulse accumulator subsystem. The TEN bit in the TSCR register enables the timer function. The pulse accumulator subsystem is enabled with the PAEN bit in the PACTL register.

Register DDRT determines pin direction of port T when used for general-purpose I/O. When DDRT bits are set, the corresponding pin is

configured for output. On reset the DDRT bits are cleared and the corresponding pin is configured for input.

When the PUPT bit in the TMSK2 register is set, all input pins are pulled up internally by an active pull-up device. Pull-ups are disabled after reset.

Setting the RDPT bit in the TMSK2 register configures all port T outputs to have reduced drive levels. Levels are at normal drive capability after reset. The TMSK2 register can be read or written anytime after reset. Refer to [Enhanced Capture Timer](#).

**Table 3-3. 68HC(9)12D60 Port Description Summary**

Port Name	Pin Numbers		Data Direction Register (Address)	Description
	80-pin	112-pin		
Port A PA[7:0]	48–41	64–57	In/Out DDRA (\$0002)	Port A and port B pins are used for address and data in expanded modes. The port data registers are not in the address map during expanded and peripheral mode operation. When in the map, port A and port B can be read or written any time.  DDRA and DDRB are not in the address map in expanded or peripheral modes.
Port B PB[7:0]	23–16	31–24	In/Out DDRDB (\$0003)	
Port AD1 PAD1[7:0]	N/A	84/82/80 /78/76/7 4/72/70	In	Analog-to-digital converter 1 and general-purpose I/O.
Port AD0 PAD0[7:0]	60–53	83/81/79 /77/75/7 3/71/69	In	Analog-to-digital converter 0 and general-purpose I/O.
Port CAN PCAN[7:0]	72, 73 <sup>(1)</sup>	98–105	In/Out	General purpose I/O. PCAN[1:0] are used with the MSCAN12 module and cannot be used as I/O.
Port E PE[7:0]	25–28, 37–40	36–39, 53–56	PE[1:0] In PE[7:2] In/Out DDRE (\$0009)	Mode selection, bus control signals and interrupt service request signals; or general-purpose I/O.
Port P PP[7:0]	76–80, 1–3	108–112 , 1–3	In/Out DDRP (\$0057)	General-purpose I/O. PP[3:0] are used with the pulse-width modulator when enabled.
Port S PS[7:0]	70–63	96–89	In/Out DDRS (\$00D7)	Serial communications interfaces 1 and 0 and serial peripheral interface subsystems and general-purpose I/O.
Port T PT[7:0]	14–11, 7–4	18–15, 7–4	In/Out DDRT (\$00AF)	General-purpose I/O when not enabled for input capture and output compare in the timer and pulse accumulator subsystem.

1. In 80-pin QFP package only TxCAN and RxCAN are available. PortCAN[2:7] pins should either be defined as outputs or have their pull-ups enabled.

### 3.6.12 Port Pull-Up Pull-Down and Reduced Drive

MCU ports can be configured for internal pull-up. To reduce power consumption and RFI, the pin output drivers can be configured to operate at a reduced drive level. Reduced drive causes a slight increase in transition time depending on loading and should be used only for ports which have a light loading. [Table 3-4](#) summarizes the port pull-up/pull-down default status and controls.

**Table 3-4. Port Pull-Up, Pull-Down and Reduced Drive Summary**

Port Name	Resistive Input Loads	Enable Bit			Reduced Drive Control Bit		
		Register (Address)	Bit Name	Reset State	Register (Address)	Bit Name	Reset State
Port A	Pull-up	PUCR (\$000C)	PUPA	Disabled	RDRIV (\$000D)	RDPA	Full drive
Port B	Pull-up	PUCR (\$000C)	PUPB	Disabled	RDRIV (\$000D)	RDPB	Full drive
Port E:							
PE7, PE[3:2]	Pull-up	PUCR (\$000C)	PUPE	Enabled	RDRIV (\$000D)	RDPE	Full drive
PE[1:0]	Pull-up	PUCR (\$000C)	PUPE	Enabled	—		
PE[6:4]	None	—			RDRIV (\$000D)	RDPE	Full drive
Port G	Pull-up or Pull-down <sup>(1)</sup>	PUCR (\$000C)	PUPG	Enabled	RDRIV (\$000D)	RDPG	Full drive
Port H	Pull-up or Pull-down <sup>(2)</sup>	PUCR (\$000C)	PUPH	Enabled	RDRIV (\$000D)	RDPH	Full drive
Port P	Pull-up	PWCONT (\$0054)	PUPP	Disabled	PWCONT (\$0054)	RDPP	Full drive
PS[1:0]	Pull-up	PURDS (\$00D9)	PUPS0	Disabled	PURDS (\$00DB)	RDPS0	Full drive
PS[3:2]	Pull-up	PURDS (\$00D9)	PUPS1	Disabled	PURDS (\$00DB)	RDPS1	Full drive
PS[7:4]	Pull-up	PURDS (\$00D9)	PUPS2	Disabled	PURDS (\$00DB)	RDPS2	Full drive
Port T	Pull-up	TMSK2 (\$008D)	PUPT	Disabled	TMSK2 (\$008D)	TDRB	Full drive
PortCAN[1]: TxCAN	None	—			—		
PortCAN[0]: RxCAN	Pull-up	Always enabled			—		
Port CAN[7:2]	Pull-up	PCTLCAN (\$013D)	PUPCAN	Disabled	PCTLCAN (\$013D)	RDPCAN	Full drive
Port AD0	None	—			—		
Port AD1	None	—			—		

1. Pull-Up when PGUPD input pin is high, Pull-down when PGUPD input pin is low. In the 80-pin version, PGUPD is internally tied to VDD, hence PG4 is pulled up.
2. Pull-Up when PHUPD input pin is high, Pull-down when PHUPD input pin is low. In the 80-pin version, PHUPD is internally tied to VSS, hence PH4 is pulled down.



## Section 4. Registers

### 4.1 Contents

4.2	Register Block. . . . .	63
-----	-------------------------	----

### 4.2 Register Block

The register block can be mapped to any 2K byte boundary within the standard 64K byte address space by manipulating bits REG[15:11] in the INITRG register. INITRG establishes the upper five bits of the register block's 16-bit address. The register block occupies the first 512 bytes of the 2K byte block. Default addressing (after reset) is indicated in [Table 4-1](#). For additional information refer to [Operating Modes and Resource Mapping](#).

# Registers

Address	Bit 7	6	5	4	3	2	1	Bit 0	Name
\$0000	PA7	PA6	PA5	PA4	PA3	PA2	PA1	PA0	PORTA <sup>(1)</sup>
\$0001	PB7	PB6	PB5	PB4	PB3	PB2	PB1	PB0	PORTB <sup>(1)</sup>
\$0002	DDA7	DDA6	DDA5	DDA4	DDA3	DDA2	DDA1	DDA0	DDRA <sup>(1)</sup>
\$0003	DDB7	DDB6	DDB5	DDB4	DDB3	DDB2	DDB1	DDB0	DDRB <sup>(1)</sup>
\$0004	0	0	0	0	0	0	0	0	Reserved <sup>(3)</sup>
\$0005	0	0	0	0	0	0	0	0	Reserved <sup>(3)</sup>
\$0006	0	0	0	0	0	0	0	0	Reserved <sup>(3)</sup>
\$0007	0	0	0	0	0	0	0	0	Reserved <sup>(3)</sup>
\$0008	PE7	PE6	PE5	PE4	PE3	PE2	PE1	PE0	PORTE <sup>(2)</sup>
\$0009	DDE7	DDE6	DDE5	DDE4	DDE3	DDE2	0	0	DDRE <sup>(2)</sup>
\$000A	NDBE	CGMTE	PIPOE	NECLK	LSTRE	RDWE	CALE	DBENE	PEAR <sup>(3)</sup>
\$000B	SMODN	MODB	MODA	ESTR	IVIS	EBSWAI	0	EME	MODE <sup>(3)</sup>
\$000C	PUPH	PUPG	0	PUPE	0	0	PUPB	PUPA	PUCR <sup>(3)</sup>
\$000D	0	RDPH	RDPG	0	RDPE	0	RDPB	RDPA	RDRIV <sup>(3)</sup>
\$000E	0	0	0	0	0	0	0	0	Reserved <sup>(3)</sup>
\$000F	0	0	0	0	0	0	0	0	Reserved <sup>(3)</sup>
\$0010	RAM15	RAM14	RAM13	RAM12	RAM11	0	0	0	INITRM
\$0011	REG15	REG14	REG13	REG12	REG11	0	0	MMSWAI	INITRG
\$0012	EE15	EE14	EE13	EE12	0	0	0	EEON	INITEE
\$0013	MAPROM	NDRF	RFSTR1	RFSTR0	EXSTR1	EXSTR0	ROMON28	ROMON32	MISC
\$0014	RTIE	RSWAI	RSBCK	Reserved	RTBYP	RTR2	RTR1	RTR0	RTICTL
\$0015	RTIF	0	0	0	0	0	0	0	RTIFLG
\$0016	CME	FCME	FCMCOP	WCOP	DISR	CR2	CR1	CR0	COPCTL
\$0017	Bit 7	6	5	4	3	2	1	Bit 0	COPRST
\$0018	0	0	0	0	0	0	0	0	Reserved
\$0019	0	0	0	0	0	0	0	0	Reserved
\$001A	0	0	0	0	0	0	0	0	Reserved
\$001B	0	0	0	0	0	0	0	0	Reserved
\$001C	0	0	0	0	0	0	0	0	Reserved
\$001D	0	0	0	0	0	0	0	0	Reserved
\$001E	IRQE	IRQEN	DLY	0	0	0	0	0	INTCR
\$001F	1	1	PSEL5	PSEL4	PSEL3	PSEL2	PSEL1	0	HPRIO
\$0020	BKEN1	BKEN0	BKPM	0	BK1ALE	BK0ALE	0	0	BRKCT0
\$0021	0	BKDBE	BKMBH	BKMBL	BK1RWE	BK1RW	BK0RWE	BK0RW	BRKCT1
\$0022	Bit 15	14	13	12	11	10	9	Bit 8	BRKAH

**Table 4-1. 68HC(9)12D60 Register Map (Sheet 1 of 8)**



Address	Bit 7	6	5	4	3	2	1	Bit 0	Name
\$0023	Bit 7	6	5	4	3	2	1	Bit 0	BRKAL
\$0024	Bit 15	14	13	12	11	10	9	Bit 8	BRKDH
\$0025	Bit 7	6	5	4	3	2	1	Bit 0	BRKDL
\$0026	0	0	0	0	0	0	0	0	reserved
\$0027	0	0	0	0	0	0	0	0	reserved
\$0028	PG7	PG6	PG5	PG4	PG3	PG2	PG1	PG0	PORTG
\$0029	PH7	PH6	PH5	PH4	PH3	PH2	PH1	PH0	PORTH
\$002A	DDG7	DDG6	DDG5	DDG4	DDG3	DDG2	DDG1	DDG0	DDRG
\$002B	DDH7	DDH6	DDH5	DDH4	DDH3	DDH2	DDH1	DDH0	DDRH
\$002C	WI2CE	KWIEG6	KWIEG5	KWIEG4	KWIEG3	KWIEG2	KWIEG1	KWIEG0	KWIEG
\$002D	KWIEH7	KWIEH6	KWIEH5	KWIEH4	KWIEH3	KWIEH2	KWIEH1	KWIEH0	KWIEH
\$002E	0	KWIFG6	KWIFG5	KWIFG4	KWIFG3	KWIFG2	KWIFG1	KWIFG0	KWIFG
\$002F	KWIFH7	KWIFH6	KWIFH5	KWIFH4	KWIFH3	KWIFH2	KWIFH1	KWIFH0	KWIFH
\$0030–\$0037	Unimplemented <sup>(4)</sup>								Reserved
\$0038	0	0	SYN5	SYN4	SYN3	SYN2	SYN1	SYN0	SYNR
\$0039	0	0	0	0	0	REFDV2	REFDV1	REFDV0	REFDV
\$003A	0	0	0	0	0	0	0	0	Reserved
\$003B	LOCKIF	LOCK	0	0	0	0	LHIF	LHOME	PLLFLG
\$003C	LOCKIE	PLLON	AUTO	ACQ	0	PSTP	LHIE	NOLHM	PLLCR
\$003D	0	BCSP	BCSS	0	0	MCS	0	0	CLKSEL
\$003E	0	0	SLDV5	SLDV4	SLDV3	SLDV2	SLDV1	SLDV0	SLOW
\$003F	0	0	0	0	0	0	0	0	Reserved
\$0040	CON23	CON01	PCKA2	PCKA1	PCKA0	PCKB2	PCKB1	PCKB0	PWCLK
\$0041	PCLK3	PCLK2	PCLK1	PCLK0	PPOL3	PPOL2	PPOL1	PPOL0	PWPOL
\$0042	0	0	0	0	PWEN3	PWEN2	PWEN1	PWEN0	PWEN
\$0043	0	Bit 6	5	4	3	2	1	Bit 0	PWPRES
\$0044	Bit 7	6	5	4	3	2	1	Bit 0	PWSCAL0
\$0045	Bit 7	6	5	4	3	2	1	Bit 0	PWSCNT0
\$0046	Bit 7	6	5	4	3	2	1	Bit 0	PWSCAL1
\$0047	Bit 7	6	5	4	3	2	1	Bit 0	PWSCNT1
\$0048	Bit 7	6	5	4	3	2	1	Bit 0	PWCNT0
\$0049	Bit 7	6	5	4	3	2	1	Bit 0	PWCNT1
\$004A	Bit 7	6	5	4	3	2	1	Bit 0	PWCNT2
\$004B	Bit 7	6	5	4	3	2	1	Bit 0	PWCNT3
\$004C	Bit 7	6	5	4	3	2	1	Bit 0	PWPER0
\$004D	Bit 7	6	5	4	3	2	1	Bit 0	PWPER1
\$004E	Bit 7	6	5	4	3	2	1	Bit 0	PWPER2

Table 4-1. 68HC(9)12D60 Register Map (Sheet 2 of 8)

# Registers

Address	Bit 7	6	5	4	3	2	1	Bit 0	Name
\$004F	Bit 7	6	5	4	3	2	1	Bit 0	PWPER3
\$0050	Bit 7	6	5	4	3	2	1	Bit 0	PWDTY0
\$0051	Bit 7	6	5	4	3	2	1	Bit 0	PWDTY1
\$0052	Bit 7	6	5	4	3	2	1	Bit 0	PWDTY2
\$0053	Bit 7	6	5	4	3	2	1	Bit 0	PWDTY3
\$0054	0	0	0	PSWAI	CENTR	RDPP	PUPP	PSBCK	PWCTL
\$0055	DISCR	DISCP	DISCAL	0	0	0	0	0	PWTST
\$0056	PP7	PP6	PP5	PP4	PP3	PP2	PP1	PP0	PORTP
\$0057	DDP7	DDP6	DDP5	DDP4	DDP3	DDP2	DDP1	DDP0	DDRP
\$0058	0	0	0	0	0	0	0	0	Reserved
\$0059	0	0	0	0	0	0	0	0	Reserved
\$005A	0	0	0	0	0	0	0	0	Reserved
\$005B	0	0	0	0	0	0	0	0	Reserved
\$005C	0	0	0	0	0	0	0	0	Reserved
\$005D	0	0	0	0	0	0	0	0	Reserved
\$005E	0	0	0	0	0	0	0	0	Reserved
\$005F	0	0	0	0	0	0	0	0	Reserved
\$0060	Reserved								ATD0CTL0
\$0061									ATD0CTL1
\$0062	ADPU	AFFC	AWAI	0	0	0	ASCIE	ASCIF	ATD0CTL2
\$0063	0	0	0	0	0	0	FRZ1	FRZ0	ATD0CTL3
\$0064	S10BM	SMP1	SMP0	PRS4	PRS3	PRS2	PRS1	PRS0	ATD0CTL4
\$0065	0	S8CM	SCAN	MULT	CD	CC	CB	CA	ATD0CTL5
\$0066	SCF	0	0	0	0	CC2	CC1	CC0	ATD0STAT0
\$0067	CCF7	CCF6	CCF5	CCF4	CCF3	CCF2	CCF1	CCF0	ATD0STAT1
\$0068	SAR9	SAR8	SAR7	SAR6	SAR5	SAR4	SAR3	SAR2	ATD0TEST H
\$0069	SAR1	SAR0	RST	TSTOUT	TST3	TST2	TST1	TST0	ATD0TESTL
\$006A–\$006E	0	0	0	0	0	0	0	0	Reserved
\$006F	PAD07	PAD06	PAD05	PAD04	PAD03	PAD02	PAD01	PAD00	PORTAD0
\$0070	Bit 15	14	13	12	11	10	9	Bit 8	ADR00H
\$0071	Bit 7	Bit 6	0	0	0	0	0	0	ADR00L
\$0072	Bit 15	14	13	12	11	10	9	Bit 8	ADR01H
\$0073	Bit 7	Bit 6	0	0	0	0	0	0	ADR01L
\$0074	Bit 15	14	13	12	11	10	9	Bit 8	ADR02H
\$0075	Bit 7	Bit 6	0	0	0	0	0	0	ADR02L
\$0076	Bit 15	14	13	12	11	10	9	Bit 8	ADR03H
\$0077	Bit 7	Bit 6	0	0	0	0	0	0	ADR03L

**Table 4-1. 68HC(9)12D60 Register Map (Sheet 3 of 8)**

Address	Bit 7	6	5	4	3	2	1	Bit 0	Name
\$0078	Bit 15	14	13	12	11	10	9	Bit 8	ADR04H
\$0079	Bit 7	Bit 6	0	0	0	0	0	0	ADR04L
\$007A	Bit 15	14	13	12	11	10	9	Bit 8	ADR05H
\$007B	Bit 7	Bit 6	0	0	0	0	0	0	ADR05L
\$007C	Bit 15	14	13	12	11	10	9	Bit 8	ADR06H
\$007D	Bit 7	Bit 6	0	0	0	0	0	0	ADR06L
\$007E	Bit 15	14	13	12	11	10	9	Bit 8	ADR07H
\$007F	Bit 7	Bit 6	0	0	0	0	0	0	ADR07L
\$0080	IOS7	IOS6	IOS5	IOS4	IOS3	IOS2	IOS1	IOS0	TIOS
\$0081	FOC7	FOC6	FOC5	FOC4	FOC3	FOC2	FOC1	FOC0	CFORC
\$0082	OC7M7	OC7M6	OC7M5	OC7M4	OC7M3	OC7M2	OC7M1	OC7M0	OC7M
\$0083	OC7D7	OC7D6	OC7D5	OC7D4	OC7D3	OC7D2	OC7D1	OC7D0	OC7D
\$0084	Bit 15	14	13	12	11	10	9	Bit 8	TCNT
\$0085	Bit 7	6	5	4	3	2	1	Bit 0	TCNT
\$0086	TEN	TSWAI	TSBCK	TFFCA	Reserved				TSCR
\$0087	Reserved								TQCR
\$0088	OM7	OL7	OM6	OL6	OM5	OL5	OM4	OL4	TCTL1
\$0089	OM3	OL3	OM2	OL2	OM1	OL1	OM0	OL0	TCTL2
\$008A	EDG7B	EDG7A	EDG6B	EDG6A	EDG5B	EDG5A	EDG4B	EDG4A	TCTL3
\$008B	EDG3B	EDG3A	EDG2B	EDG2A	EDG1B	EDG1A	EDG0B	EDG0A	TCTL4
\$008C	C7I	C6I	C5I	C4I	C3I	C2I	C1I	C0I	TMSK1
\$008D	TOI	0	PUPT	RDPT	TCRE	PR2	PR1	PR0	TMSK2
\$008E	C7F	C6F	C5F	C4F	C3F	C2F	C1F	C0F	TFLG1
\$008F	TOF	0	0	0	0	0	0	0	TFLG2
\$0090	Bit 15	14	13	12	11	10	9	Bit 8	TC0
\$0091	Bit 7	6	5	4	3	2	1	Bit 0	TC0
\$0092	Bit 15	14	13	12	11	10	9	Bit 8	TC1
\$0093	Bit 7	6	5	4	3	2	1	Bit 0	TC1
\$0094	Bit 15	14	13	12	11	10	9	Bit 8	TC2
\$0095	Bit 7	6	5	4	3	2	1	Bit 0	TC2
\$0096	Bit 15	14	13	12	11	10	9	Bit 8	TC3
\$0097	Bit 7	6	5	4	3	2	1	Bit 0	TC3
\$0098	Bit 15	14	13	12	11	10	9	Bit 8	TC4
\$0099	Bit 7	6	5	4	3	2	1	Bit 0	TC4
\$009A	Bit 15	14	13	12	11	10	9	Bit 8	TC5
\$009B	Bit 7	6	5	4	3	2	1	Bit 0	TC5
\$009C	Bit 15	14	13	12	11	10	9	Bit 8	TC6
\$009D	Bit 7	6	5	4	3	2	1	Bit 0	TC6

**Table 4-1. 68HC(9)12D60 Register Map (Sheet 4 of 8)**

# Registers

Address	Bit 7	6	5	4	3	2	1	Bit 0	Name
\$009E	Bit 15	14	13	12	11	10	9	Bit 8	TC7
\$009F	Bit 7	6	5	4	3	2	1	Bit 0	TC7
\$00A0	0	PAEN	PAMOD	PEDGE	CLK1	CLK0	PAOVI	PAI	PACTL
\$00A1	0	0	0	0	0	0	PAOVF	PAIF	PAFLG
\$00A2	Bit 7	6	5	4	3	2	1	Bit 0	PACN3
\$00A3	Bit 7	6	5	4	3	2	1	Bit 0	PACN2
\$00A4	Bit 7	6	5	4	3	2	1	Bit 0	PACN1
\$00A5	Bit 7	6	5	4	3	2	1	Bit 0	PACN0
\$00A6	MCZI	MODMC	RDMCL	ICLAT	FLMC	MCEN	M CPR1	M CPR0	MCCTL
\$00A7	MCZF	0	0	0	POL F3	POL F2	POL F1	POL F0	MCFLG
\$00A8	0	0	0	0	PA3EN	PA2EN	PA1EN	PA0EN	ICPACR
\$00A9	0	0	0	0	0	0	DLY1	DLY0	DLYCT
\$00AA	NOVW7	NOVW6	NOVW5	NOVW4	NOVW3	NOVW2	NOVW1	NOVW0	ICOVW
\$00AB	SH37	SH26	SH15	SH04	TFMOD	PACMX	BUFEN	LATQ	ICSYS
\$00AC	0	0	0	0	0	0	0	0	Reserved
\$00AD	0	0	0	0	0	0	TCBYP	0	TIMTST
\$00AE	PT7	PT6	PT5	PT4	PT3	PT2	PT1	PT0	PORTT
\$00AF	DDT7	DDT6	DDT5	DDT4	DDT3	DDT2	DDT1	DDT0	DDRT
\$00B0	0	PBEN	0	0	0	0	PBOVI	0	PBCTL
\$00B1	0	0	0	0	0	0	PBOVF	0	PBFLG
\$00B2	Bit 7	6	5	4	3	2	1	Bit 0	PA3H
\$00B3	Bit 7	6	5	4	3	2	1	Bit 0	PA2H
\$00B4	Bit 7	6	5	4	3	2	1	Bit 0	PA1H
\$00B5	Bit 7	6	5	4	3	2	1	Bit 0	PA0H
\$00B6	Bit 15	14	13	12	11	10	9	Bit 8	MCCNTH
\$00B7	Bit 7	6	5	4	3	2	1	Bit 0	MCCNTL
\$00B8	Bit 15	14	13	12	11	10	9	Bit 8	TC0H
\$00B9	Bit 7	6	5	4	3	2	1	Bit 0	TC0H
\$00BA	Bit 15	14	13	12	11	10	9	Bit 8	TC1H
\$00BB	Bit 7	6	5	4	3	2	1	Bit 0	TC1H
\$00BC	Bit 15	14	13	12	11	10	9	Bit 8	TC2H
\$00BD	Bit 7	6	5	4	3	2	1	Bit 0	TC2H
\$00BE	Bit 15	14	13	12	11	10	9	Bit 8	TC3H
\$00BF	Bit 7	6	5	4	3	2	1	Bit 0	TC3H
\$00C0	BTST	BSPL	BRLD	SBR12	SBR11	SBR10	SBR9	SBR8	SC0BDH
\$00C1	SBR7	SBR6	SBR5	SBR4	SBR3	SBR2	SBR1	SBR0	SC0BDL
\$00C2	LOOPS	WOMS	RSRC	M	WAKE	ILT	PE	PT	SC0CR1
\$00C3	TIE	TCIE	RIE	ILIE	TE	RE	RWU	SBK	SC0CR2

**Table 4-1. 68HC(9)12D60 Register Map (Sheet 5 of 8)**

Address	Bit 7	6	5	4	3	2	1	Bit 0	Name
\$00C4	TDRE	TC	RDRF	IDLE	OR	NF	FE	PF	SC0SR1
\$00C5	SCSWAI	MIE	MDL1	MDL0	0	0	0	RAF	SC0SR2
\$00C6	R8	T8	0	0	0	0	0	0	SC0DRH
\$00C7	R7/T7	R6/T6	R5/T5	R4/T4	R3/T3	R2/T2	R1/T1	R0/T0	SC0DRL
\$00C8	BTST	BSPL	BRLD	SBR12	SBR11	SBR10	SBR9	SBR8	SC1BDH
\$00C9	SBR7	SBR6	SBR5	SBR4	SBR3	SBR2	SBR1	SBR0	SC1BDL
\$00CA	LOOPS	WOMS	RSRC	M	WAKE	ILT	PE	PT	SC1CR1
\$00CB	TIE	TCIE	RIE	ILIE	TE	RE	RWU	SBK	SC1CR2
\$00CC	TDRE	TC	RDRF	IDLE	OR	NF	FE	PF	SC1SR1
\$00CD	SCSWAI	0	0	0	0	0	0	RAF	SC1SR2
\$00CE	R8	T8	0	0	0	0	0	0	SC1DRH
\$00CF	R7/T7	R6/T6	R5/T5	R4/T4	R3/T3	R2/T2	R1/T1	R0/T0	SC1DRL
\$00D0	SPIE	SPE	SWOM	MSTR	CPOL	CPHA	SSOE	LSBF	SP0CR1
\$00D1	0	0	0	0	0	0	SPSWAI	SPC0	SP0CR2
\$00D2	0	0	0	0	0	SPR2	SPR1	SPR0	SP0BR
\$00D3	SPIF	WCOL	0	MODF	0	0	0	0	SP0SR
\$00D4	0	0	0	0	0	0	0	0	Reserved
\$00D5	Bit 7	6	5	4	3	2	1	Bit 0	SP0DR
\$00D6	PS7	PS6	PS5	PS4	PS3	PS2	PS1	PS0	PORTS
\$00D7	DDS7	DDS6	DDS5	DDS4	DDS3	DDS2	DDS1	DDS0	DDRS
\$00D8	0	0	0	0	0	0	0	0	Reserved
\$00D9	0	RDPS2	RDPS1	RDPS0	0	PUPS2	PUPS1	PUPS0	PURDS
\$00DA– \$00DF	0	0	0	0	0	0	0	0	Reserved
\$00E0– \$00EF	Unimplemented <sup>(4)</sup>								Reserved
\$00F0	NOBDML	NOSHB	Reserved		1	EESWAI	PROTLCK	EERC	EEMCR
\$00F1	SHPROT	1	1	BPROT4	BPROT3	BPROT2	BPROT1	BPROT0	EEPROT
\$00F2	0	0	0	0	0	0	0	0	Reserved
\$00F3	BULKP	0	0	BYTE	ROW	ERASE	EELAT	EEPGM	EEPROM
\$00F4 <sup>(5)</sup>	0	0	0	0	0	0	0	LOCK	FEE32LCK
\$00F5 <sup>(5)</sup>	0	0	0	0	0	0	0	BOOTP	FEE32MCR
\$00F6 <sup>(5)</sup>	FSTE	GADR	HVT	FENLV	FDISVFP	VTCK	STRE	MWPR	FEETST
\$00F7 <sup>(5)</sup>	0	0	0	FEESWAI	SVFP	ERAS	LAT	ENPE	FEE32CTL
\$00F8 <sup>(5)</sup>	0	0	0	0	0	0	0	LOCK	FEE28LCK
\$00F9 <sup>(5)</sup>	0	0	0	0	0	0	0	BOOTP	FEE28MCR
\$00FA <sup>(5)</sup>	FSTE	GADR	HVT	FENLV	FDISVFP	VTCK	STRE	MWPR	FEETST

**Table 4-1. 68HC(9)12D60 Register Map (Sheet 6 of 8)**

# Registers

Address	Bit 7	6	5	4	3	2	1	Bit 0	Name
\$00FB <sup>(5)</sup>	0	0	0	FEESWAI	SVFP	ERAS	LAT	ENPE	FEE28CTL
\$00FC– \$00FF	Unimplemented <sup>(4)</sup>								Reserved
\$0100	0	0	CSWAI	SYNCH	TLNKEN	SLPAK	SLPRQ	SFTRES	CMCR0
\$0101	0	0	0	0	0	LOOPB	WUPM	CLKSRC	CMCR1
\$0102	SJW1	SJW0	BRP5	BRP4	BRP3	BRP2	BRP1	BRP0	CBTR0
\$0103	SAMP	TSEG22	TSEG21	TSEG20	TSEG13	TSEG12	TSEG11	TSEG10	CBTR1
\$0104	WUPIF	RWRNIF	TWRNIF	RERRIF	TERRIF	BOFFIF	OVRIF	RXF	CRFLG
\$0105	WUPIE	RWRNIE	TWRNIE	RERRIE	TERRIE	BOFFIE	OVRIE	RXFIE	CRIER
\$0106	0	ABTAK2	ABTAK1	ABTAK0	0	TXE2	TXE1	TXE0	CTFLG
\$0107	0	ABTRQ2	ABTRQ1	ABTRQ0	0	TXEIE2	TXEIE1	TXEIE0	CTCR
\$0108	0	0	IDAM1	IDAM0	0	IDHIT2	IDHIT1	IDHIT0	CIDAC
\$0109– \$010D	Unimplemented <sup>(4)</sup>								Reserved
\$010E	RXERR7	RXERR6	RXERR5	RXERR4	RXERR3	RXERR2	RXERR1	RXERR0	CRXERR
\$010F	TXERR7	TXERR6	TXERR5	TXERR4	TXERR3	TXERR2	TXERR1	TXERR0	CTXERR
\$0110	AC7	AC6	AC5	AC4	AC3	AC2	AC1	AC0	CIDAR0
\$0111	AC7	AC6	AC5	AC4	AC3	AC2	AC1	AC0	CIDAR1
\$0112	AC7	AC6	AC5	AC4	AC3	AC2	AC1	AC0	CIDAR2
\$0113	AC7	AC6	AC5	AC4	AC3	AC2	AC1	AC0	CIDAR3
\$0114	AM7	AM6	AM5	AM4	AM3	AM2	AM1	AM0	CIDMR0
\$0115	AM7	AM6	AM5	AM4	AM3	AM2	AM1	AM0	CIDMR1
\$0116	AM7	AM6	AM5	AM4	AM3	AM2	AM1	AM0	CIDMR2
\$0117	AM7	AM6	AM5	AM4	AM3	AM2	AM1	AM0	CIDMR3
\$0118	AC7	AC6	AC5	AC4	AC3	AC2	AC1	AC0	CIDAR4
\$0119	AC7	AC6	AC5	AC4	AC3	AC2	AC1	AC0	CIDAR5
\$011A	AC7	AC6	AC5	AC4	AC3	AC2	AC1	AC0	CIDAR6
\$011B	AC7	AC6	AC5	AC4	AC3	AC2	AC1	AC0	CIDAR7
\$011C	AM7	AM6	AM5	AM4	AM3	AM2	AM1	AM0	CIDMR4
\$011D	AM7	AM6	AM5	AM4	AM3	AM2	AM1	AM0	CIDMR5
\$011E	AM7	AM6	AM5	AM4	AM3	AM2	AM1	AM0	CIDMR6
\$011F	AM7	AM6	AM5	AM4	AM3	AM2	AM1	AM0	CIDMR7
\$0120– \$013C	Unimplemented <sup>(4)</sup>								Reserved
\$013D	0	0	0	0	0	0	PUPCAN	RDPCAN	PCTLCAN
\$013E	PCAN7	PCAN6	PCAN5	PCAN4	PCAN3	PCAN2	TxCAN	RxCAN	PORTCAN
\$013F	DDCAN7	DDCAN6	DDCAN5	DDCAN4	DDCAN3	DDCAN2	0	0	DDRCAN
\$0140– \$014F	RECEIVE BUFFER								RxFG

**Table 4-1. 68HC(9)12D60 Register Map (Sheet 7 of 8)**

Address	Bit 7	6	5	4	3	2	1	Bit 0	Name
\$0150– \$015F	TRANSMIT BUFFER 0								Tx0
\$0160– \$016F	TRANSMIT BUFFER 1								Tx1
\$0170– \$017F	TRANSMIT BUFFER 2								Tx2
\$0180– \$01DF	Unimplemented <sup>(4)</sup>								Reserved
\$01E0	Reserved								ATD1CTL0
\$01E1	Reserved								ATD1CTL1
\$01E2	ADPU	AFFC	AWAI	0	0	0	ASCIE	ASCIF	ATD1CTL2
\$01E3	0	0	0	0	0	0	FRZ1	FRZ0	ATD1CTL3
\$01E4	S10BM	SMP1	SMP0	PRS4	PRS3	PRS2	PRS1	PRS0	ATD1CTL4
\$01E5	0	S8CM	SCAN	MULT	CD	CC	CB	CA	ATD1CTL5
\$01E6	SCF	0	0	0	0	CC2	CC1	CC0	ATD1STAT0
\$01E7	CCF7	CCF6	CCF5	CCF4	CCF3	CCF2	CCF1	CCF0	ATD1STAT1
\$01E8	SAR9	SAR8	SAR7	SAR6	SAR5	SAR4	SAR3	SAR2	ATD1TESTH
\$01E9	SAR1	SAR0	RST	TSTOUT	TST3	TST2	TST1	TST0	ATD1TESTL
\$01EA–\$ 01EE	0	0	0	0	0	0	0	0	Reserved
\$01EF	PAD17	PAD16	PAD15	PAD14	PAD13	PAD12	PAD11	PAD10	PORTAD1
\$01F0	Bit 15	14	13	12	11	10	9	Bit 8	ADR10H
\$01F1	Bit 7	Bit 6	0	0	0	0	0	0	ADR10L
\$01F2	Bit 15	14	13	12	11	10	9	Bit 8	ADR11H
\$01F3	Bit 7	Bit 6	0	0	0	0	0	0	ADR11L
\$01F4	Bit 15	14	13	12	11	10	9	Bit 8	ADR12H
\$01F5	Bit 7	Bit 6	0	0	0	0	0	0	ADR12L
\$01F6	Bit 15	14	13	12	11	10	9	Bit 8	ADR13H
\$01F7	Bit 7	Bit 6	0	0	0	0	0	0	ADR13L
\$01F8	Bit 15	14	13	12	11	10	9	Bit 8	ADR14H
\$01F9	Bit 7	Bit 6	0	0	0	0	0	0	ADR14L
\$01FA	Bit 15	14	13	12	11	10	9	Bit 8	ADR15H
\$01FB	Bit 7	Bit 6	0	0	0	0	0	0	ADR15L
\$01FC	Bit 15	14	13	12	11	10	9	Bit 8	ADR16H
\$01FD	Bit 7	Bit 6	0	0	0	0	0	0	ADR16L
\$01FE	Bit 15	14	13	12	11	10	9	Bit 8	ADR17H
\$01FF	Bit 7	Bit 6	0	0	0	0	0	0	ADR17L



= Reserved or unimplemented bits.

**Table 4-1. 68HC(9)12D60 Register Map (Sheet 8 of 8)**

# Registers

1. Port A, port B and data direction registers DDRA, DDRB are not in map in expanded and peripheral modes.
2. Port E and DDRE not in map in peripheral mode; also not in map in expanded modes with EME set.
3. Registers also not in map in peripheral mode.
4. Data read at these locations is undefined.
5. Available on 68HC912D60 only. Registers are unimplemented on 68HC12D60 - data read at these locations is undefined.



## Section 5. Operating Modes and Resource Mapping

### 5.1 Contents

5.2	Introduction . . . . .	73
5.3	Operating Modes . . . . .	73
5.4	Background Debug Mode . . . . .	76
5.5	Internal Resource Mapping . . . . .	79
5.6	Memory Maps . . . . .	86

### 5.2 Introduction

Eight possible operating modes determine the operating configuration of the 68HC(9)12D60. Each mode has an associated default memory map and external bus configuration. After reset, most system resources can be mapped to other addresses by writing to the appropriate control registers.

### 5.3 Operating Modes

The operating mode out of reset is determined by the states of the BKGD, MODB, and MODA pins during reset.

The SMODN, MODB, and MODA bits in the MODE register show current operating mode and provide limited mode switching during operation.

## Operating Modes and Resource Mapping

The states of the BKGD, MODB, and MODA pins are latched into these bits on the rising edge of the reset signal.

**Table 5-1. Mode Selection**

BKGD	MODB	MODA	Mode	Port A	Port B
1	0	0	Normal Single Chip	G.P. I/O	G.P. I/O
1	0	1	Normal Expanded Narrow	ADDR/DATA	ADDR
1	1	0	Reserved (Forced to Peripheral)	—	—
1	1	1	Normal Expanded Wide	ADDR/DATA	ADDR/DATA
0	0	0	Special Single Chip	G.P. I/O	G.P. I/O
0	0	1	Special Expanded Narrow	ADDR/DATA	ADDR
0	1	0	Special Peripheral	ADDR/DATA	ADDR/DATA
0	1	1	Special Expanded Wide	ADDR/DATA	ADDR/DATA

There are two basic types of operating modes:

Normal modes — some registers and bits are protected against accidental changes.

Special modes — allow greater access to protected control registers and bits for special purposes such as testing and emulation.

For operation above 105°C, the 68HC(9)12D60 (M temperature range product only) is limited to single chip modes of operation.

A system development and debug feature, background debug mode (BDM), is available in all modes. In special single-chip mode, BDM is active immediately after reset.

### 5.3.1 Normal Operating Modes

These modes provide three operating configurations. Background debugging is available in all three modes, but must first be enabled for some operations by means of a BDM background command, then activated.

**Normal Single-Chip Mode** — There are no external address and data buses in this mode. The MCU operates as a stand-alone device and all program and data resources are on-chip. External port pins normally associated with address and data buses can be used for general-purpose I/O.

**Normal Expanded Wide Mode** — This is a normal mode of operation in which the expanded bus is present with a 16-bit data bus. Ports A and B are used for the 16-bit multiplexed address/data bus.

**Normal Expanded Narrow Mode** — This is a normal mode of operation in which the expanded bus is present with an 8-bit data bus. Ports A and B are used for the 16-bit address bus. Port A is used as the data bus, multiplexed with addresses. In this mode, 16-bit data is presented one byte at a time, the high byte followed by the low byte. The address is automatically incremented on the second cycle.

### 5.3.2 Special Operating Modes

There are three special operating modes that correspond to normal operating modes. These operating modes are commonly used in factory testing and system development. In addition, there is a special peripheral mode, in which an external master, such as an I.C. tester, can control the on-chip peripherals.

**Special Single-Chip Mode** — This mode can be used to force the MCU to active BDM mode to allow system debug through the BKGD pin. There are no external address and data buses in this mode. The MCU operates as a stand-alone device and all program and data space are on-chip. External port pins can be used for general-purpose I/O.

**Special Expanded Wide Mode** — This mode can be used for emulation of normal expanded wide mode and emulation of normal single-chip mode. Ports A and B are used for the 16-bit multiplexed address/data bus.

**Special Expanded Narrow Mode** — This mode can be used for emulation of normal expanded narrow mode. Ports A and B are used for the 16-bit address bus. Port A is used as the data bus, multiplexed with addresses. In this mode, 16-bit data is presented one byte at a time, the high byte followed by the low byte. The address is automatically incremented on the second cycle.

**Special Peripheral Mode** — The CPU is not active in this mode. An external master can control on-chip peripherals for testing purposes. It is not possible to change to or from this mode without going through reset. Background debugging should not be used while the MCU is in special peripheral mode as internal bus conflicts between BDM and the external master can cause improper operation of both modes.

### 5.4 Background Debug Mode

Background debug mode (BDM) is an auxiliary operating mode that is used for system development. BDM is implemented in on-chip hardware and provides a full set of debug operations. Some BDM commands can be executed while the CPU is operating normally. Other BDM commands are firmware based, and require the BDM firmware to be enabled and active for execution.

In special single-chip mode, BDM is enabled and active immediately out of reset. BDM is available in all other operating modes, but must be enabled before it can be activated. BDM should not be used in special peripheral mode because of potential bus conflicts.

Once enabled, background mode can be made active by a serial command sent via the BKGD pin or execution of a CPU12 BGND instruction. While background mode is active, the CPU can interpret special debugging commands, and read and write CPU registers, peripheral registers, and locations in memory.

While BDM is active, the CPU executes code located in a small on-chip ROM mapped to addresses \$FF20 to \$FFFF, and BDM control registers are accessible at addresses \$FF00 to \$FF06. The BDM ROM replaces

the regular system vectors while BDM is active. While BDM is active, the user memory from \$FF00 to \$FFFF is not in the map except through serial BDM commands.

	Bit 7	6	5	4	3	2	1	Bit 0	
	SMODN	MODB	MODA	ESTR	IVIS	EBSWAI	0	EME	
RESET:	0	0	0	1	1	0	0	1	Special Single Chip
RESET:	0	0	1	1	1	0	0	1	Special Exp Nar
RESET:	0	1	0	1	1	0	0	1	Peripheral
RESET:	0	1	1	1	1	0	0	1	Special Exp Wide
RESET:	1	0	0	1	0	0	0	0	Normal Single Chip
RESET:	1	0	1	1	0	0	0	0	Normal Exp Nar
RESET:	1	1	1	1	0	0	0	0	Normal Exp Wide

**MODE** — Mode Register

**\$000B**

MODE controls the MCU operating mode and various configuration options. This register is not in the map in peripheral mode

SMODN, MODB, MODA — Mode Select Special, B and A

These bits show the current operating mode and reflect the status of the BKGD, MODB and MODA input pins at the rising edge of reset.

SMODN is Read anytime. May only be written in special modes (SMODN = 0). The first write is ignored;

MODB, MODA may be written once in Normal modes (SMODN = 1). Write anytime in special modes (first write is ignored) – special peripheral and reserved modes cannot be selected.

### ESTR — E Clock Stretch Enable

Determines if the E Clock behaves as a simple free-running clock or as a bus control signal that is active only for external bus cycles. ESTR is always 1 in expanded modes since it is required for address and data bus de-multiplexing and must follow stretched cycles.

0 = E never stretches (always free running).

1 = E stretches high during external access cycles and low during non-visible internal accesses (IVIS=0).

Normal modes: write once; Special modes: write anytime. Read anytime.

### IVIS — Internal Visibility

This bit determines whether internal ADDR, DATA, R/W and LSTRB signals can be seen on the external bus during accesses to internal locations. In Special Narrow Mode if this bit is set and an internal access occurs the data will appear wide on Ports A and B. This serves the same function as the EMD bit of the non-multiplexed versions of the HC12 and allows for emulation. Visibility is not available when the part is operating in a single-chip mode.

0 = No visibility of internal bus operations on external bus.

1 = Internal bus operations are visible on external bus.

Normal modes: write once; Special modes: write anytime EXCEPT the first time. Read anytime.

### EBSWAI — External Bus Module Stop in Wait Control

This bit controls access to the external bus interface when in wait mode. The module will delay before shutting down in wait mode to allow for final bus activity to complete.

0 = External bus and registers continue functioning during wait mode.

1 = External bus is shut down during wait mode.

Normal modes: write anytime; Special modes: write never. Read anytime.

### EME — Emulate Port E

In single-chip mode PORTE and DDRE are always in the map regardless of the state of this bit.

0 = PORTE and DDRE are in the memory map.

1 = If in an expanded mode, PORTE and DDRE are removed from the internal memory map. Removing the registers from the map allows the user to emulate the function of these registers externally.

Normal modes: write once; special modes: write anytime EXCEPT the first time. Read anytime.

## 5.5 Internal Resource Mapping

The internal register block, RAM, and EEPROM have default locations within the 64K byte standard address space but may be reassigned to other locations during program execution by setting bits in mapping registers INITRG, INITRM, and INITEE. During normal operating modes these registers can be written once. It is advisable to explicitly establish these resource locations during the initialization phase of program execution, even if default values are chosen, in order to protect the registers from inadvertent modification later.

Writes to the mapping registers go into effect between the cycle that follows the write and the cycle after that. To assure that there are no unintended operations, a write to one of these registers should be followed with a NOP instruction.

If conflicts occur when mapping resources, the register block will take precedence over the other resources; RAM or EEPROM addresses occupied by the register block will not be available for storage. When active, BDM ROM takes precedence over other resources, although a conflict between BDM ROM and register space is not possible. The following table shows resource mapping precedence.

In expanded modes, all address space not used by internal resources is by default external memory.

The 68HC912D60 contains 60K bytes of Flash EEPROM nonvolatile memory which can be used to store program code or static data. It is

made of the 28K byte FEE28 array mapped from \$1000 to \$7FFF at reset and of the 32 K byte FEE32 array mapped from \$8000 to \$FFFF at reset. MAPROM bit in the MISC register allows the swapping of the two flash arrays.

The 68HC12D60 contains 60K bytes of ROM memory. It is made of a 28K byte array mapped from \$1000 to \$7FFF and a 32 K byte array mapped from \$8000 to \$FFFF at reset. The MAPROM bit in the MISC register allows the swapping of the two arrays.

**Table 5-2. Mapping Precedence**

<b>Precedence</b>	<b>Resource</b>
1	BDM ROM (if active)
2	Register Space
3	RAM
4	EEPROM
5	On-Chip Flash EEPROM (68HC912D60) ROM (68HC12D60)
6	External Memory



### 5.5.1 Register Block Mapping

After reset the 512 byte register block resides at location \$0000 but can be reassigned to any 2K byte boundary within the standard 64K byte address space. Mapping of internal registers is controlled by five bits in the INITRG register. The register block occupies the first 512 bytes of the 2K byte block.

	Bit 7	6	5	4	3	2	1	Bit 0
	REG15	REG14	REG13	REG12	REG11	0	0	MMSWAI
RESET:	0	0	0	0	0	0	0	0

**INITRG** — Initialization of Internal Register Position Register **\$0011**

**REG[15:11]** — Internal register map position

These bits specify the upper five bits of the 16-bit registers address.  
 Normal modes: write once; special modes: write anytime. Read anytime.

**MMSWAI** — Memory Mapping Interface Stop in Wait Control

This bit controls access to the memory mapping interface when in Wait mode.

Normal modes: write anytime; special modes: write never. Read anytime.

0 = Memory mapping interface continues to function during Wait mode.

1 = Memory mapping interface access is shut down during Wait mode.

## Operating Modes and Resource Mapping

### 5.5.2 RAM Mapping

The 68HC(9)12D60 has 2K byte of fully static RAM that is used for storing instructions, variables, and temporary data during program execution. After reset, RAM addressing begins at location \$0000 but can be assigned to any 2K byte boundary within the standard 64K byte address space. Mapping of internal RAM is controlled by five bits in the INITRM register.

After reset, the first 512 bytes of RAM have their access inhibited by the presence of the register address space. After initial MCU configuration, it is recommended to map the register space at location \$0800.

	Bit 7	6	5	4	3	2	1	Bit 0
	RAM15	RAM14	RAM13	RAM12	RAM11	0	0	0
RESET:	0	0	0	0	0	0	0	0

**INITRM** — Initialization of Internal RAM Position Register

**\$0010**

**RAM[15:11]** — Internal RAM map position

These bits specify the upper five bits of the 16-bit RAM address. Normal modes: write once; special modes: write anytime. Read anytime.

### 5.5.3 EEPROM Mapping

The 68HC(9)12D60 has 1K bytes of EEPROM which is activated by the EEON bit in the INITEE register. Mapping of internal EEPROM is controlled by four bits in the INITEE register. After reset EEPROM address space begins at location \$0C00 but can be mapped to any 4K byte boundary within the standard 64K byte address space.

	Bit 7	6	5	4	3	2	1	Bit 0
	EE15	EE14	EE13	EE12	0	0	0	EEON
RESET:	0	0	0	0	0	0	0	1

**INITEE**— Initialization of Internal EEPROM Position Register **\$0012**

**EE[15:12]** — Internal EEPROM map position

These bits specify the upper four bits of the 16-bit EEPROM address.  
 Normal modes: write once; special modes: write anytime. Read anytime.

**EEON** — internal EEPROM On (Enabled)

This bit is forced to one in single-chip modes.  
 Read or write anytime.  
 0 = Removes the EEPROM from the map.  
 1 = Places the on-chip EEPROM in the memory map at the address selected by EE[15:12].

# Operating Modes and Resource Mapping

## 5.5.4 Miscellaneous System Control Register

Additional mapping and external resource controls are available. To use external resources the part must be operated in one of the expanded modes.

	Bit 7	6	5	4	3	2	1	Bit 0	
	MAPROM	NDRF	RFSTR1	RFSTR0	EXSTR1	EXSTR0	ROMON28	ROMON32	
RESET:	0	0	0	0	1	1	0	0	Exp Modes
RESET:	0	0	0	0	1	1	1	1	SC Modes

**MISC** — Miscellaneous Mapping Control Register

**\$0013**

Normal modes: write once; Special modes: write anytime. Read anytime.

### MAPROM — Map Location of ROM

This bit is used to swap the location of the on-chip Flash EEPROM (68HC912D60) or ROM (68HC12D60) arrays.

0 = 28K byte array is mapped from \$1000 to \$7FFF, 32K byte array is mapped from \$8000 to \$FFFF.

1 = 28K byte is mapped from \$9000 to \$FFFF, 32K byte array is mapped from \$0000 to \$7FFF.

### NDRF — Narrow Data Bus for Register-Following Map Space

This bit enables a narrow bus feature for the 512 byte Register-Following Map. This is useful for accessing 8-bit peripherals and allows 8-bit and 16-bit external memory devices to be mixed in a system. In Expanded Narrow (eight bit) modes, Single Chip Modes, and Peripheral mode, this bit has no effect.

0 = Makes Register-Following MAP space act as a full 16 bit data bus.

1 = Makes the Register-Following MAP space act the same as an 8 bit only external data bus (data only goes through port A externally).

The Register-Following space is mapped from \$0200 to \$03FF after reset, which is next to the register map. If the registers are moved this space follows.

### RFSTR1, RFSTR0 — Register Following Stretch

This two bit field determines the amount of clock stretch on accesses to the 512 byte Register Following Map. It is valid regardless of the state of the NDRF bit. In Single Chip and Peripheral Modes this bit has no meaning or effect.

**Table 5-3. RFSTR Stretch Bit Definition**

RFSTR1	RFSTR0	Number of E Clocks Stretched
0	0	0
0	1	1
1	0	2
1	1	3

### EXSTR1, EXSTR0 — External Access Stretch

This two bit field determines the amount of clock stretch on accesses to the External Address Space. In Single Chip and Peripheral Modes this bit has no meaning or effect.

**Table 5-4. EXSTR Stretch Bit Definition**

EXSTR1	EXSTR0	Number of E Clocks Stretched
0	0	0
0	1	1
1	0	2
1	1	3

### ROMON28, ROMON32 — Enable bits for ROM

These bits are used to enable the Flash EEPROM arrays FEE28 and FEE32 (68HC912D60) or ROM arrays ROM28 and ROM32 (68HC12D60) respectively.

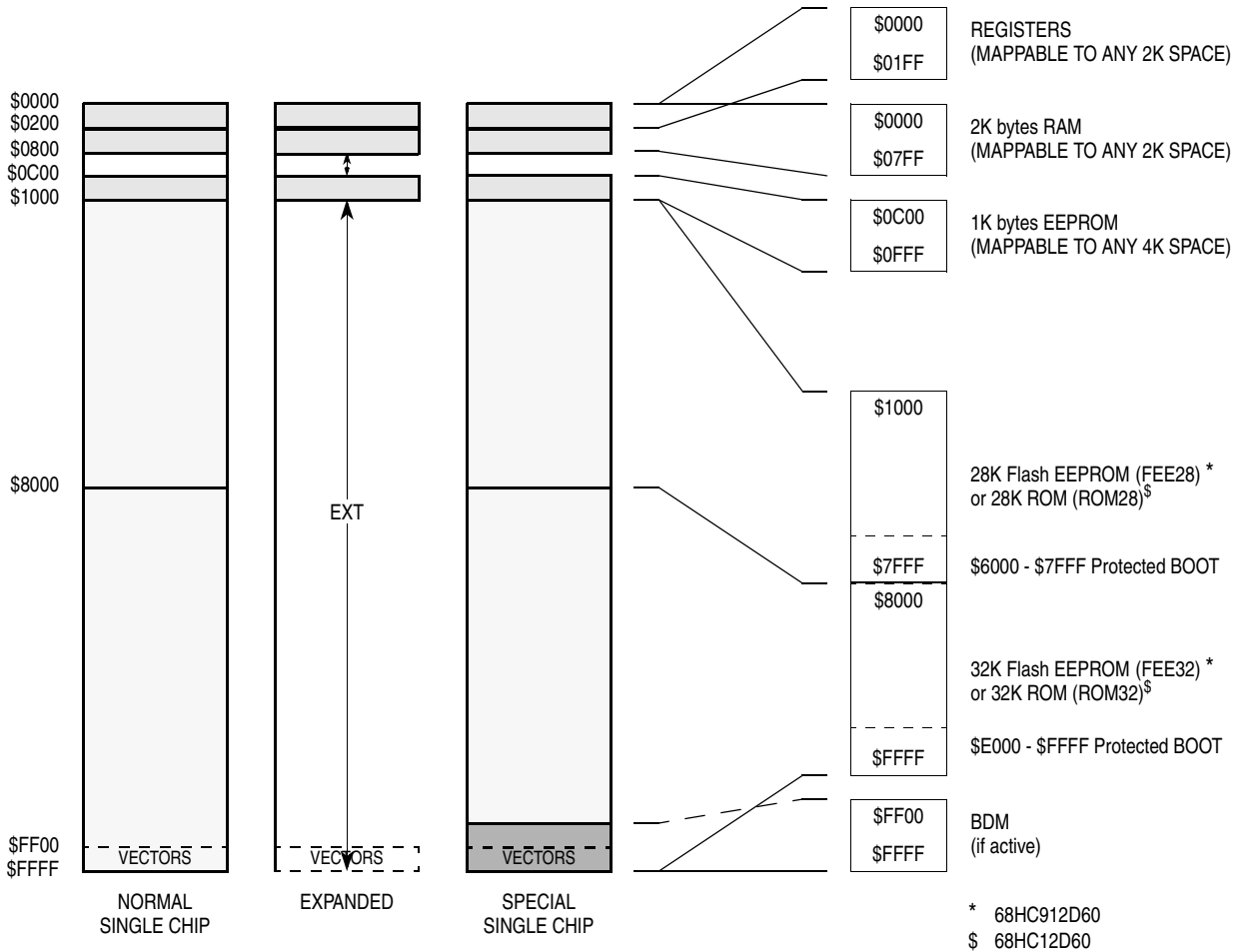
0 = Corresponding Flash EEPROM/ROM array disabled from the memory map.

1 = Corresponding Flash EEPROM/ROM array enabled in the memory map.

# Operating Modes and Resource Mapping

## 5.6 Memory Maps

The following diagrams illustrate the memory map for each mode of operation immediately after reset.



**Figure 5-1. 68HC(9)12D60 Memory Map**

## Section 6. Bus Control and Input/Output

### 6.1 Contents

6.2	Introduction . . . . .	87
6.3	Detecting Access Type from External Signals . . . . .	87
6.4	Registers . . . . .	88

### 6.2 Introduction

Internally the 68HC(9)12D60 has full 16-bit data paths, but depending upon the operating mode and control registers, the external multiplexed bus may be 8 or 16 bits. There are cases where 8-bit and 16-bit accesses can appear on adjacent cycles using the  $\overline{\text{LSTRB}}$  signal to indicate 8- or 16-bit data.

It is possible to have a mix of 8 and 16 bit peripherals attached to the external multiplexed bus, using the NDRF bit in the MISC register while in expanded wide modes.

### 6.3 Detecting Access Type from External Signals

The external signals  $\overline{\text{LSTRB}}$ ,  $\overline{\text{R/W}}$ , and  $\text{A0}$  can be used to determine the type of bus access that is taking place. Accesses to the internal RAM module are the only type of access that produce  $\overline{\text{LSTRB}} = \text{A0} = 1$ , because the internal RAM is specifically designed to allow misaligned 16-bit accesses in a single cycle. In these cases the data for the address

that was accessed is on the low half of the data bus and the data for address + 1 is on the high half of the data bus.

**Figure 6-1. Access Type vs. Bus Control Pins**

LSTRB	A0	R/W	Type of Access
1	0	1	8-bit read of an even address
0	1	1	8-bit read of an odd address
1	0	0	8-bit write of an even address
0	1	0	8-bit write of an odd address
0	0	1	16-bit read of an even address
1	1	1	16-bit read of an odd address (low/high data swapped)
0	0	0	16-bit write to an even address
1	1	0	16-bit write to an even address (low/high data swapped)

## 6.4 Registers

Not all registers are visible in the 68HC(9)12D60 memory map under certain conditions. In special peripheral mode the first 16 registers associated with bus expansion are removed from the memory map.

In expanded modes, some or all of port A, port B, and port E are used for expansion buses and control signals. In order to allow emulation of the single-chip functions of these ports, some of these registers must be rebuilt in an external port replacement unit. In any expanded mode, port A, and port B, are used for address and data lines so registers for these ports, as well as the data direction registers for these ports, are removed from the on-chip memory map and become external accesses.

In any expanded mode, port E pins may be needed for bus control (e.g., ECLK,  $\overline{R/W}$ ). To regain the single-chip functions of port E, the emulate port E (EME) control bit in the MODE register may be set. In this special case of expanded mode and EME set, PORTE and DDRE registers are removed from the on-chip memory map and become external accesses so port E may be rebuilt externally.



	Bit 7	6	5	4	3	2	1	Bit 0
Single Chip	PA7	PA6	PA5	PA4	PA3	PA2	PA1	PA0
RESET:	—	—	—	—	—	—	—	—
Expanded & Periph:	ADDR15/ DATA15	ADDR14/ DATA14	ADDR13/ DATA13	ADDR12/ DATA12	ADDR11/ DATA11	ADDR10/ DATA10	ADDR9/ DATA9	ADDR8/ DATA8
Expanded narrow	ADDR15/ DATA15/ DATA7	ADDR14/ DATA14/ DATA6	ADDR13/ DATA13/ DATA5	ADDR12/ DATA12/ DATA4	ADDR11/ DATA11/ DATA3	ADDR10/ DATA10/ DATA2	ADDR9/ DATA9/ DATA1	ADDR8/ DATA8/ DATA0

**PORTA** — Port A Register

**\$0000**

Bits PA[7:0] are associated respectively with addresses ADDR[15:8], DATA[15:8] and DATA[7:0], in narrow mode. When this port is not used for external addresses such as in single-chip mode, these pins can be used as general-purpose I/O. DDRA determines the primary direction of each pin. This register is not in the on-chip map in expanded and peripheral modes. Read and write anytime.

	Bit 7	6	5	4	3	2	1	Bit 0
	DDA7	DDA6	DDA5	DDA4	DDA3	DDA2	DDA1	DDA0
RESET:	0	0	0	0	0	0	0	0

**DDRA** — Port A Data Direction Register

**\$0002**

This register determines the primary direction for each port A pin when functioning as a general-purpose I/O port. DDRA is not in the on-chip map in expanded and peripheral modes. Read and write anytime.

- 0 = Associated pin is a high-impedance input
- 1 = Associated pin is an output

## Bus Control and Input/Output

	Bit 7	6	5	4	3	2	1	Bit 0
Single Chip	PB7	PB6	PB5	PB4	PB3	PB2	PB1	PB0
RESET:	—	—	—	—	—	—	—	—
Expanded & Periph:	ADDR7/ DATA7	ADDR6/ DATA6	ADDR5/ DATA5	ADDR4/ DATA4	ADDR3/ DATA3	ADDR2/ DATA2	ADDR1/ DATA1	ADDR0/ DATA0
Expanded narrow	ADDR7	ADDR6	ADDR5	ADDR4	ADDR3	ADDR2	ADDR1	ADDR0

**PORTB** — Port B Register

**\$0001**

Bits PB[7:0] are associated with addresses ADDR[7:0] and DATA[7:0] (except in narrow mode) respectively. When this port is not used for external addresses such as in single-chip mode, these pins can be used as general-purpose I/O. DDRB determines the primary direction of each pin. This register is not in the on-chip map in expanded and peripheral modes. Read and write anytime.

	Bit 7	6	5	4	3	2	1	Bit 0
	DDB7	DDB6	DDB5	DDB4	DDB3	DDB2	DDB1	DDB0
RESET:	0	0	0	0	0	0	0	0

**DDRB** — Port B Data Direction Register

**\$0003**

This register determines the primary direction for each port B pin when functioning as a general-purpose I/O port. DDRB is not in the on-chip map in expanded and peripheral modes. Read and write anytime.

0 = Associated pin is a high-impedance input

1 = Associated pin is an output

	BIT 7	6	5	4	3	2	1	BIT 0
	PE7	PE6	PE5	PE4	PE3	PE2	PE1	PE0
RESET:	—	—	—	—	—	—	—	—
Alt. Pin Function	$\overline{DBE}$ or $\overline{ECLK}$ or CAL	MODB or IPIPE1 or CGMTST	MODA or IPIPE0	ECLK	$\overline{LSTRB}$ or $\overline{BDTAGL}$ or $\overline{TAGLO}$	R/W	$\overline{IRQ}$	$\overline{XIRQ}$

**PORTE** — Port E Register

**\$0008**

This register is associated with external bus control signals and interrupt inputs, including data bus enable ( $\overline{DBE}$ ), mode select (MODB/IPIPE1, MODA/IPIPE0), E clock, size ( $\overline{LSTRB}$ ), read/write (R/W),  $\overline{IRQ}$ , and  $\overline{XIRQ}$ . When the associated pin is not used for one of these specific functions, the pin can be used as general-purpose I/O. The port E assignment register (PEAR) selects the function of each pin. DDRE determines the primary direction of each port E pin when configured to be general-purpose I/O.

Some of these pins have software selectable pull-ups ( $\overline{DBE}$ ,  $\overline{LSTRB}$ , R/W,  $\overline{IRQ}$ , and  $\overline{XIRQ}$ ). A single control bit enables the pull-ups for all these pins which are configured as inputs.

This register is not in the map in peripheral mode or expanded modes when the EME bit is set.

Read and write anytime.

	Bit 7	6	5	4	3	2	1	Bit 0
	DDE7	DDE6	DDE5	DDE4	DDE3	DDE2	0	0
RESET:	0	0	0	0	0	0	0	0

**DDRE** — Port E Data Direction Register

**\$0009**

This register determines the primary direction for each port E pin configured as general-purpose I/O.

## Bus Control and Input/Output

0 = Associated pin is a high-impedance input

1 = Associated pin is an output

PE[1:0] are associated with  $\overline{XIRQ}$  and  $\overline{IRQ}$  and cannot be configured as outputs. These pins can be read regardless of whether the alternate interrupt functions are enabled.

This register is not in the map in peripheral mode and expanded modes while the EME control bit is set.

Read and write anytime.

	BIT 7	6	5	4	3	2	1	BIT 0	
	NDBE	CGMTE	PIPOE	NECLK	LSTRE	RDWE	CALE	DBENE	
RESET:	0	0	0	0	0	0	0	0	Normal Expanded
RESET:	0	0	1	0	1	1	0	0	Special Expanded
RESET:	1	1	0	1	0	0	0	0	Peripheral
RESET:	1	0	0	1	0	0	0	0	Normal single chip
RESET:	0	0	1	0	1	1	0	0	Special single chip

**PEAR** — Port E Assignment Register

**\$000A**

The PEAR register is used to choose between the general-purpose I/O functions and the alternate bus control functions of port E. When an alternate control function is selected, the associated DDRE bits are overridden.

The reset condition of this register depends on the mode of operation because bus-control signals are needed immediately after reset in some modes.

In normal single-chip mode, no external bus control signals are needed so all of port E is configured for general-purpose I/O.

In normal expanded modes, the reset vector is located in external memory. The  $\overline{\text{DBE}}$  and E clock are required for de-multiplexing address and data, but  $\overline{\text{LSTRB}}$  and  $\overline{\text{R/W}}$  are only needed by the system when there are external writable resources. Therefore in normal expanded modes, only the  $\overline{\text{DBE}}$  and E clock are configured for their alternate bus control functions and the other bits of port E are configured for general-purpose I/O. If the normal expanded system needs any other bus-control signals, PEAR would need to be written before any access that needed the additional signals.

In special expanded modes,  $\overline{\text{DBE}}$ , IPIPE1, IPIPE0, E,  $\overline{\text{LSTRB}}$ , and  $\overline{\text{R/W}}$  are configured as bus-control signals.

In peripheral mode, the PEAR register is not accessible for reads or writes. However, the CGMTE control bit is reset to one to configure PE6 as a test output from the PLL module.

#### NDBE — No Data Bus Enable

Normal: write once; Special: write anytime EXCEPT the first. Read anytime.

0 = PE7 is used for  $\overline{\text{DBE}}$ , external control of data enable on memories, or inverted E clock.

1 = PE7 is the CAL function if CALE bit is set in PEAR register or general-purpose I/O.

NDBE controls the use of the  $\overline{\text{DBE}}$  pin of Port E. The NDBE bit has no effect in Single Chip or Peripheral Modes. The associated pin will default to the CAL function if the CALE bit is set in PEAR register or otherwise to an I/O.

#### CGMTE — Clock Generator Module Testing Enable

Normal: write never; Special: write anytime EXCEPT the first. Read anytime.

0 = PE6 is general-purpose I/O or pipe output.

1 = PE6 is a test signal output from the CGM module (no effect in single chip or normal expanded modes). PIPOE = 1 overrides this function and forces PE6 to be a pipe status output signal.

### PIPOE — Pipe Status Signal Output Enable

Normal: write once; Special: write anytime EXCEPT the first time.  
Read anytime.

0 = PE[6:5] are general-purpose I/O (if CGMTE = 1, PE6 is a test output signal from the CGM module).

1 = PE[6:5] are outputs and indicate the state of the instruction queue (only effective in expanded modes).

### NECLK — No External E Clock

Normal single chip: write once; special single chip: write anytime; all other modes: write never. Read anytime. In peripheral mode, E is an input and in all other modes, E is an output.

0 = PE4 is the external E-clock pin subject to the following limitation: In single-chip modes, to get an E clock output signal, it is necessary to have ESTR = 0 in addition to NECLK = 0.

1 = PE4 is a general-purpose I/O pin.

### LSTRE — Low Strobe ( $\overline{\text{LSTRB}}$ ) Enable

Normal: write once; Special: write anytime EXCEPT the first time.  
Read anytime. This bit has no effect in single-chip modes or normal expanded narrow mode.

0 = PE3 is a general-purpose I/O pin.

1 = PE3 is configured as the  $\overline{\text{LSTRB}}$  bus-control output, provided the MCU is not in single chip or normal expanded narrow modes.

$\overline{\text{LSTRB}}$  is used during external writes. After reset in normal expanded mode,  $\overline{\text{LSTRB}}$  is disabled. If needed, it should be enabled before external writes. External reads do not normally need  $\overline{\text{LSTRB}}$  because all 16 data bits can be driven even if the MCU only needs 8 bits of data.

In normal expanded narrow mode this pin is reset to an output driving high allowing the pin to be an output while in and immediately after reset.

$\overline{\text{TAGLO}}$  is a shared function of the PE3/ $\overline{\text{LSTRB}}$  pin. In special expanded modes with LSTRE set and the BDM tagging on, a zero at the falling edge of E tags the instruction word low byte being read into the instruction queue.

### RDWE — Read/Write Enable

Normal: write once; Special: write anytime EXCEPT the first time.  
Read anytime. This bit has no effect in single-chip modes.

0 = PE2 is a general-purpose I/O pin.

1 = PE2 is configured as the  $\overline{R/W}$  pin. In single chip modes, RDWE has no effect and PE2 is a general-purpose I/O pin.

$\overline{R/W}$  is used for external writes. After reset in normal expanded mode, it is disabled. If needed it should be enabled before any external writes.

### CALE — Calibration Reference Enable

Read and write anytime.

0 = Calibration reference is disabled and PE7 is general-purpose I/O in single chip or peripheral modes or if the NDBE bit is set.

1 = Calibration reference is enabled on PE7 in single chip and peripheral modes or if the NDBE bit is set.

### DBENE — $\overline{DBE}$ or Inverted E Clock on Port E[7]

Normal modes: write once. Special modes: write anytime EXCEPT the first; read anytime.

DBENE controls which signal is output on PE7 when NDBE control bit is cleared. The inverted E clock output can be used to latch the address for demultiplexing. It has the same behaviour as the E clock, except it is inverted. Please note that in the case of idle expansion bus, the 'not E clock' signal could stay high for many cycles.

The DBNE bit has no effect in single chip or peripheral modes and PE7 is defaulted to the CAL function if the CALE bit is set in the PEAR register or to an I/O otherwise.

0 = PE7 pin used for  $\overline{DBE}$  external control of data enable on memories in expanded modes when NDBE = 0

1 = PE7 pin used for inverted E clock output in expanded modes when NDBE = 0

## Bus Control and Input/Output

	Bit 7	6	5	4	3	2	1	Bit 0
	PUPH	PUPG	0	PUPE	0	0	PUPB	PUPA
RESET:	1	1	0	1	0	0	0	0

**PUCR** — Pull-Up Control Register

**\$000C**

These bits select pull-up resistors for any pin in the corresponding port that is currently configured as an input. This register is not in the map in peripheral mode.

Read and write anytime.

**PUPH** — Pull-Up or Pull-Down Port H Enable

0 = Port H pull-ups are disabled.

1 = Enable pull-up/down devices for all port H input pins.

**PUPG** — Pull-Up or Pull-Down Port G Enable

0 = Port G pull-ups are disabled.

1 = Enable pull-up/down devices for all port G input pins.

**PUPE** — Pull-Up Port E Enable

0 = Port E pull-ups on PE7 and PE[3:0] are disabled.

1 = Enable pull-up devices for port E input pins PE7 and PE[3:0].

**PUPB** — Pull-Up Port B Enable

0 = Port B pull-ups are disabled.

1 = Enable pull-up devices for all port B input pins.

This bit has no effect if port B is being used as part of the address/data bus (the pull-ups are inactive).

**PUPA** — Pull-Up Port A Enable

0 = Port A pull-ups are disabled.

1 = Enable pull-up devices for all port A input pins.

This bit has no effect if port A is being used as part of the address/data bus (the pull-ups are inactive).



	Bit 7	6	5	4	3	2	1	Bit 0
	0	RDPH	RDPG	0	RDPE	0	RDPB	RDPA
RESET:	0	0	0	0	0	0	0	0

**RDRIV** — Reduced Drive of I/O Lines

**\$000D**

These bits select reduced drive for the associated port pins. This gives reduced power consumption and reduced RFI with a slight increase in transition time (depending on loading). The reduced drive function is independent of which function is being used on a particular port.

This register is not in the map in peripheral mode.

Normal: write once; Special: write anytime EXCEPT the first time. Read anytime.

**RDPH** — Reduced Drive of Port H

0 = All port H output pins have full drive enabled.

1 = All port H output pins have reduced drive capability.

**RDPG** — Reduced Drive of Port G

0 = All port G output pins have full drive enabled.

1 = All port G output pins have reduced drive capability.

**RDPE** — Reduced Drive of Port E

0 = All port E output pins have full drive enabled.

1 = All port E output pins have reduced drive capability.

**RDPB** — Reduced Drive of Port B

0 = All port B output pins have full drive enabled.

1 = All port B output pins have reduced drive capability.

**RDPA** — Reduced Drive of Port A

0 = All port A output pins have full drive enabled.

1 = All port A output pins have reduced drive capability.



## Section 7. Flash Memory

### 7.1 Contents

7.2	Introduction . . . . .	99
7.3	Overview . . . . .	100
7.4	Flash EEPROM Control Block . . . . .	100
7.5	Flash EEPROM Arrays . . . . .	100
7.6	Flash EEPROM Registers . . . . .	101
7.7	Operation . . . . .	105
7.8	Programming the Flash EEPROM . . . . .	108
7.9	Erasing the Flash EEPROM . . . . .	111
7.10	Program/Erase Protection Interlocks . . . . .	113
7.11	Stop or Wait Mode . . . . .	113

### 7.2 Introduction

The two Flash EEPROM modules (32-Kbyte and 28-Kbyte) for the 68HC912D60 serve as electrically erasable and programmable, non-volatile ROM emulation memory. The modules can be used for program code that must either execute at high speed or is frequently executed, such as operating system kernels and standard subroutines, or they can be used for static data which is read frequently. The Flash EEPROM is ideal for program storage for single-chip applications allowing for field reprogramming.

## 7.3 Overview

The Flash EEPROM array is arranged in a 16-bit configuration and may be read as either bytes, aligned words or misaligned words. Access time is one bus cycle for byte and aligned word access and two bus cycles for misaligned word operations.

The Flash EEPROM module requires an external program/erase voltage ( $V_{FP}$ ) to program or erase the Flash EEPROM array. The external program/erase voltage is provided to the Flash EEPROM module via an external  $V_{FP}$  pin. To prevent damage to the flash array,  $V_{FP}$  should always be within the specification as defined in [Table 20-10](#) in [Electrical Specifications](#). Programming is by byte or aligned word. The Flash EEPROM module supports bulk erase only.

The Flash EEPROM module has hardware interlocks which protect stored data from accidental corruption. An erase- and program-protected 8-Kbyte block for boot routines is located at \$6000–\$7FFF or \$E000–\$FFFF depending upon the mapped location of the Flash EEPROM arrays.

## 7.4 Flash EEPROM Control Block

A 4-byte register block for each module controls the Flash EEPROM module operation. Configuration information is specified and programmed independently from the contents of the Flash EEPROM array. At reset, the 4-byte register section starts at address \$00F4/\$00F8.

## 7.5 Flash EEPROM Arrays

After reset, the 32K Flash EEPROM array is located from addresses \$8000 to \$FFFF and the 28K Flash EEPROM array is from \$1000 to \$7FFF. In expanded modes, the Flash EEPROM arrays are turned off. The Flash EEPROM can be mapped to an alternate address range. See [Operating Modes and Resource Mapping](#).

## 7.6 Flash EEPROM Registers

	Bit 7	6	5	4	3	2	1	Bit 0
	0	0	0	0	0	0	0	LOCK
RESET:	0	0	0	0	0	0	0	0

**FEE32LCK/FEE28LCK** — Flash EEPROM Lock Control Register

**\$00F4/\$00F8**

In normal modes the LOCK bit can only be written once after reset.

**LOCK** — Lock Register Bit

0 = Enable write to FEE<sub>xx</sub>MCR register

1 = Disable write to FEE<sub>xx</sub>MCR register

	Bit 7	6	5	4	3	2	1	Bit 0
	0	0	0	0	0	0	0	BOOTP
RESET:	0	0	0	0	0	0	0	1

**FEE32MCR/FEE28MCR** — Flash EEPROM Module Configuration Register

**\$00F5/\$00F9**

This register controls the operation of the Flash EEPROM array. BOOTP cannot be changed when the LOCK control bit in the FEE<sub>xx</sub>LCK register is set or if ENPE in the FEE<sub>xx</sub>CTL register is set.

**BOOTP** — Boot Protect

The boot blocks are located at \$6000–\$7FFF and \$E000–\$FFFF for each Flash EEPROM module.

0 = Enable erase and program of 8K byte boot block

1 = Disable erase and program of 8K byte boot block

	Bit 7	6	5	4	3	2	1	Bit 0
	FSTE	GADR	HVT	FENLV	FDISVFP	VTCK	STRE	MWPR
RESET:	0	0	0	0	0	0	0	0

**FEE32TST/FEE28TST** — Flash EEPROM Module Test Register

**\$00F6/\$00FA**

In normal mode, writes to FEETST control bits have no effect and always read zero. The Flash EEPROM module cannot be placed in test mode inadvertently during normal operation.

**FSTE** — Stress Test Enable

0 = Disables the gate/drain stress circuitry

1 = Enables the gate/drain stress circuitry

**GADR** — Gate/Drain Stress Test Select

0 = Selects the drain stress circuitry

1 = Selects the gate stress circuitry

**HVT** — Stress Test High Voltage Status

0 = High voltage not present during stress test

1 = High voltage present during stress test

**FENLV** — Enable Low Voltage

0 = Disables low voltage transistor in current reference circuit

1 = Enables low voltage transistor in current reference circuit

**FDISVFP** — Disable Status  $V_{FP}$  Voltage Lock

When the  $V_{FP}$  pin is below normal programming voltage the Flash module will not allow writing to the LAT bit; the user cannot erase or program the Flash module. The FDISVFP control bit enables writing to the LAT bit regardless of the voltage on the  $V_{FP}$  pin.

0 = Enable the automatic lock mechanism if  $V_{FP}$  is low

1 = Disable the automatic lock mechanism if  $V_{FP}$  is low

**VTCK —  $V_T$  Check Test Enable**

When VTCK is set, the Flash EEPROM module uses the  $V_{FP}$  pin to control the control gate voltage; the sense amp time-out path is disabled. This allows for indirect measurements of the bit cells program and erase threshold. If  $V_{FP} < V_{ZBRK}$  (breakdown voltage) the control gate will equal the  $V_{FP}$  voltage.

If  $V_{FP} > V_{ZBRK}$  the control gate will be regulated by the following equation:  $V_{control\ gate} = V_{ZBRK} + 0.44 \times (V_{FP} - V_{ZBRK})$

0 =  $V_T$  test disable

1 =  $V_T$  test enable

**STRE — Spare Test Row Enable**

The spare test row consists of one Flash EEPROM array row. The reserved word at location 31 contains production test information which must be maintained through several erase cycles. When STRE is set, the decoding for the spare test row overrides the address lines which normally select the other rows in the array.

0 = LIB accesses are to the Flash EEPROM array

1 = Spare test row in array enabled if SMOD is active

**MWPR — Multiple Word Programming**

Used primarily for testing, if MPWR = 1, the two least-significant address lines ADDR[1:0] will be ignored when programming a Flash EEPROM location. The word location addressed if ADDR[1:0] = 00, along with the word location addressed if ADDR[1:0] = 10, will both be programmed with the same word data from the programming latches. This bit should not be changed during programming.

0 = Multiple word programming disabled

1 = Program 32 bits of data

	Bit 7	6	5	4	3	2	1	Bit 0
	0	0	0	FEESWAI	SVFP	ERAS	LAT	ENPE
RESET:	0	0	0	0	0	0	0	0

**FEE32CTL/FEE28CTL** — Flash EEPROM Control Register

**\$00F7/\$00FB**

This register controls the programming and erasure of the Flash EEPROM.

**FEESWAI** — Flash EEPROM Stop in Wait Control

0 = Do not halt Flash EEPROM clock when the part is in wait mode.

1 = Halt Flash EEPROM clock when the part is in wait mode.

**NOTE:** *The FEESWAI bit cannot be asserted if the interrupt vector resides in the Flash EEPROM array.*

**SVFP** — Status  $V_{FP}$  Voltage

SVFP is a read only bit.

0 = Voltage of  $V_{FP}$  pin is below normal programming voltage levels

1 = Voltage of  $V_{FP}$  pin is above normal programming voltage levels

**ERAS** — Erase Control

This bit can be read anytime or written when ENPE = 0. When set, all locations in the array will be erased at the same time. The boot block will be erased only if BOOTP = 0. This bit also affects the result of attempted array reads. See [Table 7-1](#) for more information. Status of ERAS cannot change if ENPE is set.

0 = Flash EEPROM configured for programming

1 = Flash EEPROM configured for erasure

**LAT** — Latch Control

This bit can be read anytime or written when ENPE = 0. When set, the Flash EEPROM is configured for programming or erasure and, upon the next valid write to the array, the address and data will be latched for the programming sequence. See [Table 7-1](#) for the effects of LAT



on array reads. A high voltage detect circuit on the  $V_{FP}$  pin will prevent assertion of the LAT bit when the programming voltage is at normal levels.

0 = Programming latches disabled

1 = Programming latches enabled

ENPE — Enable Programming/Erase

0 = Disables program/erase voltage to Flash EEPROM

1 = Applies program/erase voltage to Flash EEPROM

ENPE can be asserted only after LAT has been asserted and a write to the data and address latches has occurred. If an attempt is made to assert ENPE when LAT is negated, or if the latches have not been written to after LAT was asserted, ENPE will remain negated after the write cycle is complete.

The LAT, ERAS and BOOTP bits cannot be changed when ENPE is asserted. A write to FEE<sub>xx</sub>CTL may only affect the state of ENPE. Attempts to read a Flash EEPROM array location in the Flash EEPROM module while ENPE is asserted will not return the data addressed. See [Table 7-1](#) for more information.

Flash EEPROM module control registers may be read or written while ENPE is asserted. If ENPE is asserted and LAT is negated on the same write access, no programming or erasure will be performed.

**Table 7-1. Effects of ENPE, LAT and ERAS on Array Reads**

ENPE	LAT	ERAS	Result of Read
0	0	–	Normal read of location addressed
0	1	0	Read of location being programmed
0	1	1	Normal read of location addressed
1	–	–	Read cycle is ignored

## 7.7 Operation

The Flash EEPROM can contain program and data. On reset, it can operate as a bootstrap memory to provide the CPU with internal initialization information during the reset sequence.

## 7.7.1 Bootstrap Operation Single-Chip Mode

After reset, the CPU controlling the system will begin booting up by fetching the first program address from address \$FFFE.

## 7.7.2 Normal Operation

The Flash EEPROM allows a byte or aligned word read/write in one bus cycle. Misaligned word read/write require an additional bus cycle. The Flash EEPROM array responds to read operations only. Write operations are ignored.

## 7.7.3 Program/Erase Operation

An unprogrammed Flash EEPROM bit has a logic state of one. A bit must be programmed to change its state from one to zero. Erasing a bit returns it to a logic one. The Flash EEPROM has a minimum program/erase life of 100 cycles. Programming or erasing the Flash EEPROM is accomplished by a series of control register writes and a write to a set of programming latches.

Programming is restricted to a single byte or aligned word at a time as determined by internal signal SZ8 and ADDR[0]. The Flash EEPROM must first be completely erased prior to programming final data values. It is possible to program a location in the Flash EEPROM without erasing the entire array if the new value does not require the changing of bit values from zero to one.

**Read/Write Accesses During Program/Erase** — During program or erase operations, read and write accesses may be different from those during normal operation and are affected by the state of the control bits in the Flash EEPROM control register (FEExxCTL). The next write to any valid address to the array after LAT is set will cause the address and data to be latched into the programming latches. Once the address and data are latched, write accesses to the array will be ignored while LAT is set. Writes to the control registers will occur normally.

**Program/Erase Verification** — When programming or erasing the Flash EEPROM array, a special verification method is required to ensure

that the program/erase process is reliable, and also to provide the longest possible life expectancy. This method requires stopping the program/erase sequence at periods of  $t_{PPULSE}$  ( $t_{EPULSE}$  for erasing) to determine if the Flash EEPROM is programmed/erased. After the location reaches the proper value, it must continue to be programmed/erased with additional margin pulses to ensure that it will remain programmed/erased. Failure to provide the margin pulses could lead to corrupted or unreliable data.

**Program/Erase Sequence** — To begin a program or erase sequence the external  $V_{FP}$  voltage must be applied and stabilized. The ERAS bit must be set or cleared, depending on whether a program sequence or an erase sequence is to occur. The LAT bit will be set to cause any subsequent data written to a valid address within the Flash EEPROM to be latched into the programming address and data latches. The next Flash array write cycle must be either to the location that is to be programmed if a programming sequence is being performed, or, if erasing, to any valid Flash EEPROM array location. Writing the new address and data information to the Flash EEPROM is followed by assertion of ENPE to turn on the program/erase voltage to program/erase the new location(s). The LAT bit must be asserted and the address and data latched to allow the setting of the ENPE control bit. If the data and address have not been latched, an attempt to assert ENPE will be ignored and ENPE will remain negated after the write cycle to FEEExCTL is completed. The LAT bit must remain asserted and the ERAS bit must remain in its current state as long as ENPE is asserted. A write to the LAT bit to clear it while ENPE is set will be ignored. That is, after the write cycle, LAT will remain asserted. Likewise, an attempt to change the state of ERAS will be ignored and the state of the ERAS bit will remain unchanged.

The programming software is responsible for all timing during a program sequence. This includes the total number of program pulses ( $n_{PP}$ ), the length of the program pulse ( $t_{PPULSE}$ ), the program margin pulses ( $p_m$ ) and the delay between turning off the high voltage and verifying the operation ( $t_{VPROG}$ ).

The erase software is responsible for all timing during an erase sequence. This includes the total number of erase pulses ( $e_m$ ), the

length of the erase pulse ( $t_{EPULSE}$ ), the erase margin pulse or pulses, and the delay between turning off the high voltage and verifying the operation ( $t_{VERASE}$ ).

Software also controls the supply of the proper program/erase voltage to the  $V_{FP}$  pin, and should be at the proper level before ENPE is set during a program/erase sequence.

A program/erase cycle should not be in progress when starting another program/erase, or while attempting to read from the array.

**NOTE:** *Although clearing ENPE disables the program/erase voltage ( $V_{FP}$ ) from the  $V_{FP}$  pin to the array, care must be taken to ensure that  $V_{FP}$  is at  $V_{DD}$  whenever programming/erasing is not in progress. Not doing so could damage the part. Ensuring that  $V_{FP}$  is always greater or equal to  $V_{DD}$  can be accomplished by controlling the  $V_{FP}$  power supply with the programming software via an output pin. Alternatively, all programming and erasing can be done prior to installing the device on an application circuit board which can always connect  $V_{FP}$  to  $V_{DD}$ . Programming can also be accomplished by plugging the board into a special programming fixture which provides program/erase voltage to the  $V_{FP}$  pin.*

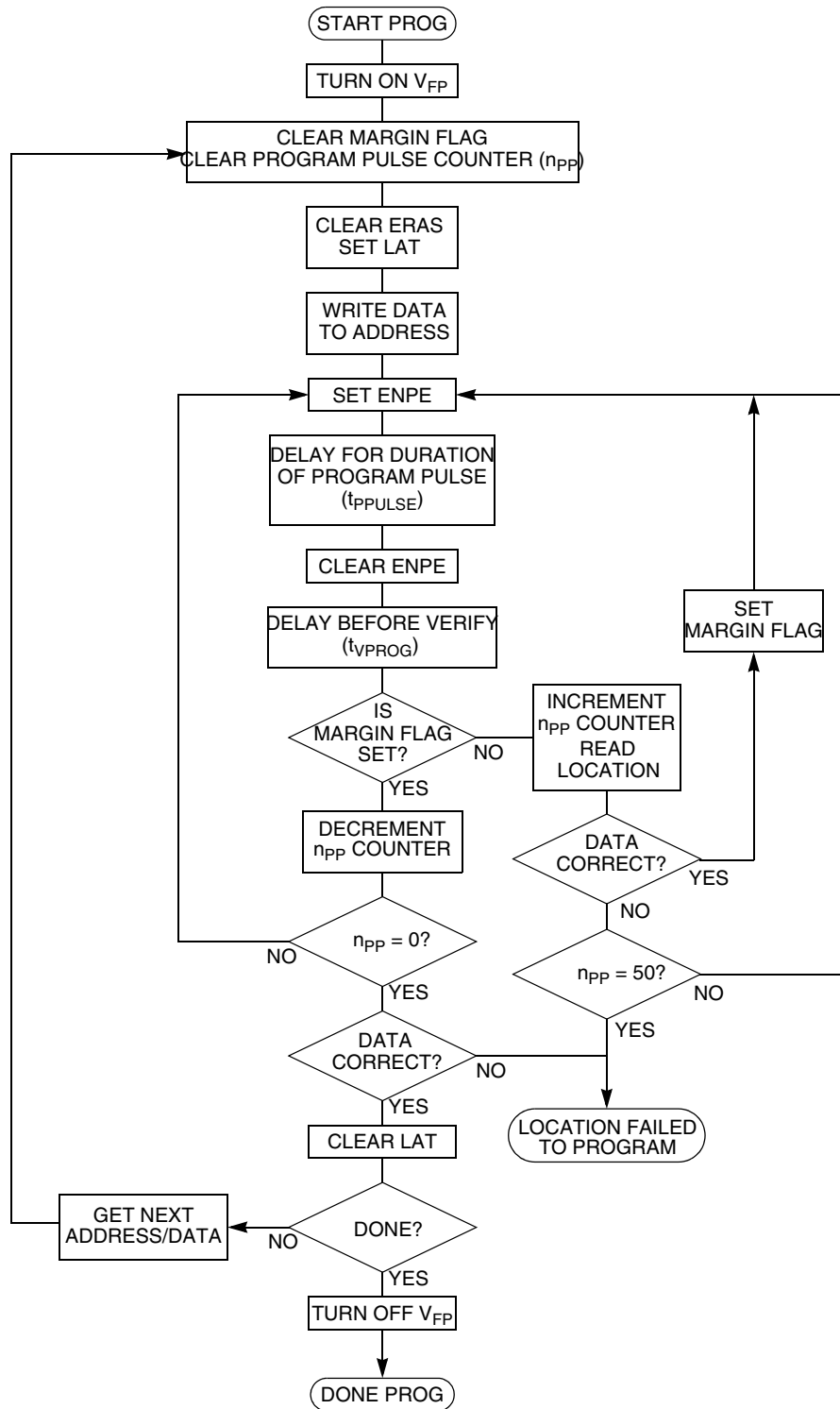
## 7.8 Programming the Flash EEPROM

Programming the Flash EEPROM is accomplished by the following sequence. The  $V_{FP}$  pin voltage must be at the proper level prior to executing step 4 the first time.

1. Apply program/erase voltage to the  $V_{FP}$  pin.
2. Clear ERAS and set the LAT bit in the FEExxCTL register to establish program mode and enable programming address and data latches.
3. Write data to a valid address. The address and data is latched. If BOOTP is asserted, an attempt to program an address in the boot block will be ignored.
4. Apply programming voltage by setting ENPE.
5. Delay for one programming pulse ( $t_{PPULSE}$ ).

6. Remove programming voltage by clearing ENPE.
7. Delay while high voltage is turning off ( $t_{V_{PROG}}$ ).
8. Read the address location to verify that it has been programmed
  - If the location is not programmed, repeat steps 4 through 7 until the location is programmed or until the specified maximum number of program pulses has been reached ( $n_{PP}$ )
  - If the location is programmed, repeat the same number of pulses as required to program the location. This provides 100% program margin.
9. Read the address location to verify that it remains programmed.
10. Clear LAT.
11. If there are more locations to program, repeat steps 2 through 10.
12. Turn off  $V_{FP}$  (reduce voltage on  $V_{FP}$  pin to  $V_{DD}$ ).

The flowchart in [Figure 7-1](#) demonstrates the recommended programming sequence.



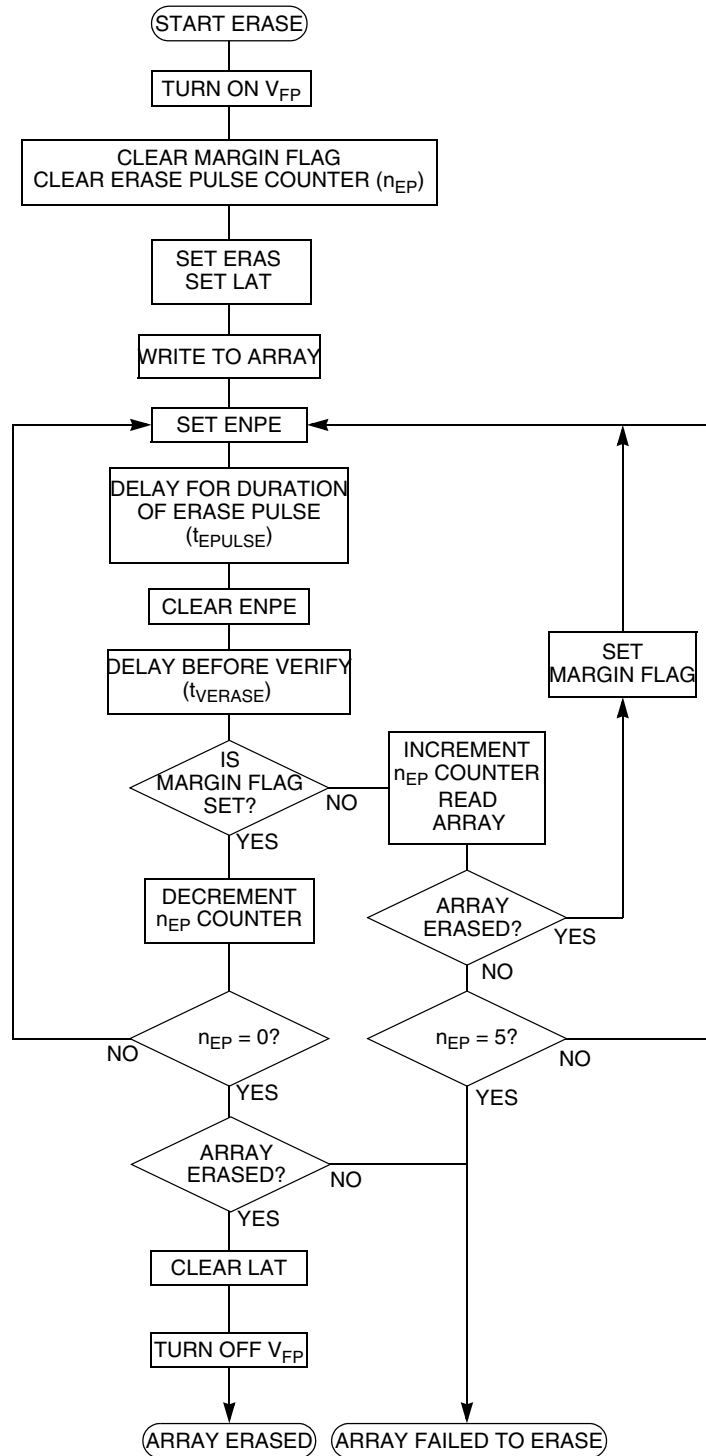
**Figure 7-1. Program Sequence Flow**

## 7.9 Erasing the Flash EEPROM

The following sequence demonstrates the recommended procedure for erasing the Flash EEPROM. The  $V_{FP}$  pin voltage must be at the proper level prior to executing step 4 the first time.

1. Turn on  $V_{FP}$  (apply program/erase voltage to the  $V_{FP}$  pin).
2. Set the LAT bit and ERAS bit to configure the Flash EEPROM for erasing.
3. Write to any valid address in the Flash array. This allows the erase voltage to be turned on; the data written and the address written are not important. The boot block will be erased only if the control bit BOOTP is negated.
4. Apply erase voltage by setting ENPE.
5. Delay for a single erase pulse ( $t_{EPULSE}$ ).
6. Remove erase voltage by clearing ENPE.
7. Delay while high voltage is turning off ( $t_{VERASE}$ ).
8. Read the entire array to ensure that the Flash EEPROM is erased.
  - If all of the Flash EEPROM locations are not erased, repeat steps 4 through 7 until either the remaining locations are erased, or until the maximum erase pulses have been applied ( $n_{EP}$ )
  - If all of the Flash EEPROM locations are erased, repeat the same number of pulses as required to erase the array. This provides 100% erase margin.
9. Read the entire array to ensure that the Flash EEPROM is erased.
10. Clear LAT.
11. Turn off  $V_{FP}$  (reduce voltage on  $V_{FP}$  pin to  $V_{DD}$ ).

The flowchart in [Figure 7-2](#) demonstrates the recommended erase sequence.



**Figure 7-2. Erase Sequence Flow**



## 7.10 Program/Erase Protection Interlocks

The Flash EEPROM program and erase mechanisms provide maximum protection from accidental programming or erasure.

The voltage required to program/erase the Flash EEPROM ( $V_{FP}$ ) is supplied via an external pin. If  $V_{FP}$  is not present, no programming/erasing will occur. Furthermore, the program/erase voltage will not be applied to the Flash EEPROM unless turned on by setting a control bit (ENPE). The ENPE bit may not be set unless the programming address and data latches have been written previously with a valid address. The latches may not be written unless enabled by setting a control bit (LAT). The LAT and ENPE control bits must be written on separate writes to the control register (FEEExxCTL) and must be separated by a write to the programming latches. The ERAS and LAT bits are also protected when ENPE is set. This prevents inadvertent switching between erase/program mode and also prevents the latched data and address from being changed after a program cycle has been initiated.

## 7.11 Stop or Wait Mode

When stop or wait commands are executed, the MCU puts the Flash EEPROM in stop or wait mode. In these modes the Flash module will cease erasure or programming immediately. It is advised not to enter stop or wait modes when programming the Flash array.

**CAUTION:** *The Flash EEPROM module requires a 250nsec delay for wake-up from STOP mode. If the operating bus frequency is greater than 4MHz, the Flash cannot be used when recovering from STOP mode when the DLY bit in the INTCR register is cleared.*



## Section 8. EEPROM Memory

### 8.1 Contents

8.2	Introduction . . . . .	115
8.3	Future EEPROM Support . . . . .	116
8.4	EEPROM Programmer's Model . . . . .	117
8.5	EEPROM Control Registers . . . . .	118

### 8.2 Introduction

The 68HC(9)12D60 EEPROM nonvolatile memory is arranged in a 16-bit configuration. The EEPROM array may be read as either bytes, aligned words or misaligned words. Access times are one bus cycle for byte and aligned word access and two bus cycles for misaligned word operations.

Programming is by byte or aligned word. Attempts to program or erase misaligned words will fail. Only the lower byte will be latched and programmed or erased. Programming and erasing of the user EEPROM can be done in all modes.

Each EEPROM byte or aligned word must be erased before programming. The EEPROM module supports byte, aligned word, row (32 bytes) or bulk erase, all using the internal charge pump. The erased state is \$FF. The EEPROM module has hardware interlocks which protect stored data from corruption by accidentally enabling the program/erase voltage. Programming voltage is derived from the internal  $V_{DD}$  supply with an internal charge pump.

## 8.3 Future EEPROM Support

Design is underway to introduce an improved EEPROM module with integrated state machine to simplify programming and erase. This will be introduced on the 68HC912D60A together with 5V programming Flash EEPROM.

[Appendix: 68HC912D60A EEPROM](#) contains detailed information to assist in software planning for future EEPROM compatibility and transition to the 68HC912D60A. Read, write and erase algorithms are fully compatible with the present EEPROM design. The key change comes in the form of a self timed state machine for erasing & writing data. This is implemented using a pre-scaler loaded from a new word register EEDIV (\$00EE) - located in a presently unused location this register can be written without effect, reading the location will return unpredictable data.

Adding 5 bytes of initialisation code to current software to load EEDIV (with value appropriate for the application's crystal frequency, EXTALi) will help ensure compatibility.

Other new features for performance improvement are disabled at reset providing a compatible algorithm for modifying the EEPROM.

**CAUTION:** *Other areas for consideration include:*

*Program/Erase is not guaranteed in Limp home mode. Clock monitor CME bit must be enabled during program/erase.*

*Program/erase should not be performed with input clock frequency <250 KHz.*

*Resonator/crystal frequency tolerance should be better than 2% total for < 2MHz, 3% total for >= 2MHz.*

*Successive writes to an EEPROM location must be preceded by an erase cycle.*

To ensure full compatibility it is recommended that all of [Appendix: 68HC912D60A EEPROM](#) be reviewed.

## 8.4 EEPROM Programmer's Model

The EEPROM module consists of two separately addressable sections. The first is a four-byte memory mapped control register block used for control, testing and configuration of the EEPROM array. The second section is the EEPROM array itself.

At reset, the four-byte register section starts at address \$00F0 and the EEPROM array is located from addresses \$0C00 to \$0FFF. For information on re-mapping the register block and EEPROM address space, refer to [Operating Modes and Resource Mapping](#).

Read/write access to the memory array section can be enabled or disabled by the EEON control bit in the INITEE register. This feature allows the access to memory mapped resources with lower priority than the EEPROM memory array. EEPROM control registers can be accessed regardless of the state of EEON. Any EEPROM erase or program operations already in progress will not be affected by modifying EEON.

Using the normal EEPROG control, it is possible to continue program/erase operations during WAIT. For lowest power consumption during WAIT, stop program/erase by turning off EEPGM.

If the STOP mode is entered during programming or erasing, program/erase voltage will be automatically turned off and the RC clock (if enabled) is stopped. However, the EEPGM control bit will remain set. When STOP mode is terminated, the program/erase voltage will be automatically turned back on if EEPGM is set.

At low bus frequencies, the RC clock must be turned on for program/erase.

The EEPROM module contains an extra byte called SHADOW byte which is loaded at reset into the EEMCR register. To program the SHADOW byte, when in special modes (SMODN=0), the NOSHB bit in EEMCR register must be cleared. Normal programming routines are used to program the SHADOW byte which becomes accessible at address \$0FC0 when NOSHB is cleared. At the next reset the SHADOW byte data is loaded into the EEMCR. The SHADOW byte can be protected from being programmed or erased by setting the SHPROT bit of EEPROT register.

## 8.5 EEPROM Control Registers

	Bit 7	6	5	4	3	2	1	Bit 0
	NOBDML	NOSHB	1 <sup>(1)</sup>	1 <sup>(1)</sup>	1	EESWAI	PROTLCK	EERC
RESET:	— <sup>(2)</sup>	— <sup>(2)</sup>	— <sup>(2)</sup>	— <sup>(2)</sup>	1	1	0	0

**EEMCR** — EEPROM Module Configuration

**\$00F0**

1. Bits 4 and 5 have test functions and should not be cleared (set to '0').
2. Loaded from SHADOW byte.

Bits[7:4] are loaded at reset from the EEPROM SHADOW byte.

**NOTE:** *Bits 5 and 4 are reserved for test purposes. These locations in the SHADOW byte should not be programmed otherwise some locations in the regular EEPROM array will no longer be visible.*

**NOBDML** — Background Debug Mode Lockout Disable

- 0 = The BDM lockout is enabled.
- 1 = The BDM lockout is disabled.

Loaded from SHADOW byte at reset.

Read anytime. Write anytime in special modes (SMODN=0).

**NOSHB** — SHADOW Byte Disable

- 0 = SHADOW byte enabled and accessible at address \$0FC0.
- 1 = Regular EEPROM array at address \$0FC0.

Loaded from SHADOW byte at reset.

Read anytime. Write anytime in special modes (SMODN=0).

When NOSHB cleared, the regular EEPROM array byte at address \$0FC0 is no longer visible. The SHADOW byte is accessed instead for both read and program/erase operations. BULK, ODD and EVEN program/erase only apply if the SHADOW byte is enabled.

**NOTE:** *Bit 6 of the SHADOW byte should not be cleared (set to '0') in order to have the full EEPROM array visible. If Bit 6 from the SHADOW byte is cleared then the following thirty-one bytes \$0FC1–\$0FFF have no meaning and are reserved by Motorola.*

**EESWAI** — EEPROM Stops in Wait Mode

- 0 = The module is not affected during WAIT mode
- 1 = The module ceases to be clocked during WAIT mode

Read and write anytime.

**NOTE:** *The EESWAI bit should be cleared if the WAIT mode vectors are mapped in the EEPROM array.*

**PROTLCK** — Block Protect Write Lock

- 0 = Block protect bits and bulk erase protection bit can be written
- 1 = Block protect bits are locked

Read anytime. Write once in normal modes (SMODN = 1), set and clear any time in special modes (SMODN = 0).

**EERC** — EEPROM Charge Pump Clock

- 0 = System clock is used as clock source for the internal charge pump. Internal RC oscillator is stopped.
- 1 = Internal RC oscillator drives the charge pump. The RC oscillator is required when the system bus clock is lower than  $f_{\text{PROG}}$ .

Read and write anytime.

Bit 7	6	5	4	3	2	1	Bit 0
SHPROT	1	1	BPROT4	BPROT3	BPROT2	BPROT1	BPROT0

RESET:      1      1      1      1      1      1      1      1

**EEPROT** — EEPROM Block Protect

**\$00F1**

Prevents accidental writes to EEPROM. Read anytime. Write anytime if EEPGM = 0 and PROTLCK = 0.

**SHPROT** — SHADOW Byte Protection

- 0 = The SHADOW byte can be programmed and erased.
- 1 = The SHADOW byte is protected from being programmed and erased.

# EEPROM Memory

## BPROT[4:0] — EEPROM Block Protection

0 = Associated EEPROM block can be programmed and erased.

1 = Associated EEPROM block is protected from being programmed and erased.

**Table 8-1. 1K byte EEPROM Block Protection**

Bit Name	Block Protected	Block Size
BPROT4	\$0C00 to \$0DFF	512 Bytes
BPROT3	\$0E00 to \$0EFF	256 Bytes
BPROT2	\$0F00 to \$0F7F	128 Bytes
BPROT1	\$0F80 to \$0FBF	64 Bytes
BPROT0	\$0FC0 to \$0FFF	64 Bytes

Bit 7	6	5	4	3	2	1	Bit 0
BULKP	0	0	BYTE	ROW	ERASE	EELAT	EEPGM

RESET:      1      0      0      0      0      0      0      0

**EEPROG** — EEPROM Control

**\$00F3**

## BULKP — Bulk Erase Protection

0 = EEPROM can be bulk erased.

1 = EEPROM is protected from being bulk or row erased.

Read anytime. Write anytime if EEPGM = 0 and PROTLCK = 0.

## BYTE — Byte and Aligned Word Erase

0 = Bulk or row erase is enabled.

1 = One byte or one aligned word erase only.

Read anytime. Write anytime if EEPGM = 0.

## ROW — Row or Bulk Erase (when BYTE = 0)

0 = Erase entire EEPROM array.

1 = Erase only one 32-byte row.

Read anytime. Write anytime if EEPGM = 0.

BYTE and ROW have no effect when ERASE = 0



**Table 8-2. Erase Selection**

BYTE	ROW	Block size
0	0	Bulk erase entire EEPROM array
0	1	Row erase 32 bytes
1	0	Byte or aligned word erase
1	1	Byte or aligned word erase

**ERASE — Erase Control**

0 = EEPROM configuration for programming.

1 = EEPROM configuration for erasure.

Read anytime. Write anytime if EEPGM = 0.

Configures the EEPROM for erasure or programming.

**EELAT — EEPROM Latch Control**

0 = EEPROM set up for normal reads.

1 = EEPROM address and data bus latches set up for programming or erasing.

Read anytime. Write anytime if EEPGM = 0.

BYTE, ROW, ERASE and EELAT bits can be written simultaneously or in any sequence.

**EEPGM — Program and Erase Enable**

0 = Disables program/erase voltage to EEPROM.

1 = Applies program/erase voltage to EEPROM.

The EEPGM bit can be set only after EELAT has been set. When EELAT and EEPGM are set simultaneously, EEPGM remains clear but EELAT is set.

The BULKP, BYTE, ROW, ERASE and EELAT bits cannot be changed when EEPGM is set. To complete a program or erase, two successive writes to clear EEPGM and EELAT bits are required before reading the programmed data. A write to an EEPROM location has no effect when EEPGM is set. Latched address and data cannot be modified during program or erase.

A program or erase operation should follow the sequence below:

1. Write BYTE, ROW and ERASE to the desired value, write EELAT = 1
2. Write a byte or an aligned word to an EEPROM address
3. Write EEPGM = 1
4. Wait for programming ( $t_{\text{PROG}}$ ) or erase ( $t_{\text{erase}}$ ) delay time
5. Write EEPGM = 0
6. Write EELAT = 0

It is possible to program/erase more bytes or words without intermediate EEPROM reads, by jumping from step 5 to step 2.

## Section 9. Resets and Interrupts

### 9.1 Contents

9.2	Introduction . . . . .	123
9.3	Maskable interrupts . . . . .	124
9.4	Latching of Interrupts . . . . .	125
9.5	Interrupt Control and Priority Registers . . . . .	127
9.6	Resets. . . . .	128
9.7	Effects of Reset . . . . .	130
9.8	Register Stacking . . . . .	131
9.9	Customer Information . . . . .	132

### 9.2 Introduction

CPU12 exceptions include resets and interrupts. Each exception has an associated 16-bit vector, which points to the memory location where the routine that handles the exception is located. Vectors are stored in the upper 128 bytes of the standard 64K byte address map.

The six highest vector addresses are used for resets and non-maskable interrupt sources. The remainder of the vectors are used for maskable interrupts, and all must be initialized to point to the address of the appropriate service routine.

### 9.2.1 Exception Priority

A hardware priority hierarchy determines which reset or interrupt is serviced first when simultaneous requests are made. Six sources are not maskable. The remaining sources are maskable, and any one of them can be given priority over other maskable interrupts.

The priorities of the non-maskable sources are:

1. POR or  $\overline{\text{RESET}}$  pin
2. Clock monitor reset
3. COP watchdog reset
4. Unimplemented instruction trap
5. Software interrupt instruction (SWI)
6.  $\overline{\text{XIRQ}}$  signal (if X bit in CCR = 0)

### 9.3 Maskable interrupts

Maskable interrupt sources include on-chip peripheral systems and external interrupt service requests. Interrupts from these sources are recognized when the global interrupt mask bit (I) in the CCR is cleared. The default state of the I bit out of reset is one, but it can be written at any time.

Interrupt sources are prioritized by default but any one maskable interrupt source may be assigned the highest priority by means of the HPRIO register. The relative priorities of the other sources remain the same.

An interrupt that is assigned highest priority is still subject to global masking by the I bit in the CCR, or by any associated local bits. Interrupt vectors are not affected by priority assignment. HPRIO can only be written while the I bit is set (interrupts inhibited). [Table 9-1](#) lists interrupt sources and vectors in default order of priority.

## 9.4 Latching of Interrupts

$\overline{XIRQ}$  is always level triggered and  $\overline{IRQ}$  can be selected as a level triggered interrupt. These level triggered interrupt pins should only be released during the appropriate interrupt service routine. Generally the interrupt service routine will handshake with the interrupting logic to release the pin. In this way, the MCU will start the interrupt service sequence only to determine that there is no longer an interrupt source. In the event that this does not occur, the trap vector will be taken.

If  $\overline{IRQ}$  is selected as an edge triggered interrupt, the hold time of the level after the active edge is independent of when the interrupt is serviced. As long as the minimum hold time is met, the interrupt will be latched inside the MCU. In this case the  $\overline{IRQ}$  edge interrupt latch is cleared automatically when the interrupt is serviced.

All of the remaining interrupts are latched by the MCU with a flag bit. These interrupt flags should be cleared during an interrupt service routine or when interrupts are masked by the I bit. By doing this, the MCU will never get an unknown interrupt source and take the trap vector.

**Table 9-1. Interrupt Vector Map**

Vector Address	Interrupt Source	CCR Mask	Local Enable	HPRIO Value to Elevate
\$FFFE, \$FFFF	Reset	None	None	–
\$FFFC, \$FFFD	Clock monitor fail reset	None	COPCTL (CME, FCME)	–
\$FFFA, \$FFFB	COP failure reset	None	COP rate selected	–
\$FFF8, \$FFF9	Unimplemented instruction trap	None	None	–
\$FFF6, \$FFF7	SWI	None	None	–
\$FFF4, \$FFF5	XIRQ	X bit	None	–
\$FFF2, \$FFF3	IRQ	I bit	INTCR (IRQEN)	\$F2
\$FFF0, \$FFF1	Real time interrupt	I bit	RTICTL (RTIE)	\$F0
\$FFEE, \$FFEF	Timer channel 0	I bit	TMSK1 (C0I)	\$EE
\$FFEC, \$FFED	Timer channel 1	I bit	TMSK1 (C1I)	\$EC
\$FFEA, \$FFEB	Timer channel 2	I bit	TMSK1 (C2I)	\$EA
\$FFE8, \$FFE9	Timer channel 3	I bit	TMSK1 (C3I)	\$E8
\$FFE6, \$FFE7	Timer channel 4	I bit	TMSK1 (C4I)	\$E6
\$FFE4, \$FFE5	Timer channel 5	I bit	TMSK1 (C5I)	\$E4
\$FFE2, \$FFE3	Timer channel 6	I bit	TMSK1 (C6I)	\$E2
\$FFE0, \$FFE1	Timer channel 7	I bit	TMSK1 (C7I)	\$E0
\$FFDE, \$FFDF	Timer overflow	I bit	TMSK2 (TOI)	\$DE
\$FFDC, \$FFDD	Pulse accumulator overflow	I bit	PACTL (PAOVI)	\$DC
\$FFDA, \$FFDB	Pulse accumulator input edge	I bit	PACTL (PAI)	\$DA
\$FFD8, \$FFD9	SPI serial transfer complete	I bit	SP0CR1 (SPIE)	\$D8
\$FFD6, \$FFD7	SCI 0	I bit	SC0CR2 (TIE, TCIE, RIE, ILIE)	\$D6
\$FFD4, \$FFD5	SCI 1	I bit	SC1CR2 (TIE, TCIE, RIE, ILIE)	\$D4
\$FFD2, \$FFD3	ATD0 or ATD1	I bit	ATDxCTL2 (ASCIE)	\$D2
\$FFD0, \$FFD1	MSCAN wake-up	I bit	CRIER (WUPIE)	\$D0
\$FFCE, \$FFCF	Key wake-up G or H	I bit	KWIEG[6:0] and KWIEH[7:0]	\$CE
\$FFCC, \$FFCD	Modulus down counter underflow	I bit	MCCTL (MCZI)	\$CC
\$FFCA, \$FFCB	Pulse Accumulator B Overflow	I bit	PBCTL (PBOVI)	\$CA
\$FFC8, \$FFC9	MSCAN errors	I bit	CRIER (RWRNIE, TWRNIE, RERRIE, TERRIE, BOFFIE, OVRIE)	\$C8
\$FFC6, \$FFC7	MSCAN receive	I bit	CRIER (RXFIE)	\$C6
\$FFC4, \$FFC5	MSCAN transmit	I bit	CTCR (TXEIE[2:0])	\$C4
\$FFC2, \$FFC3	CGM lock and limp home	I bit	PLLCR (LOCKIE, LHIE)	\$C2
\$FF80–\$FFC1	Reserved	I bit		\$80–\$C0

## 9.5 Interrupt Control and Priority Registers

	Bit 7	6	5	4	3	2	1	Bit 0
	IRQE	IRQEN	DLY	0	0	0	0	0
RESET:	0	1	1	0	0	0	0	0

**INTCR** — Interrupt Control Register

**\$001E**

**IRQE** —  $\overline{\text{IRQ}}$  Select Edge Sensitive Only

0 =  $\overline{\text{IRQ}}$  configured for low-level recognition.

1 =  $\overline{\text{IRQ}}$  configured to respond only to falling edges (on pin PE1/ $\overline{\text{IRQ}}$ ).

IRQE can be read anytime and written once in normal modes. In special modes, IRQE can be read anytime and written anytime, except the first write is ignored.

**IRQEN** — External  $\overline{\text{IRQ}}$  Enable

The  $\overline{\text{IRQ}}$  pin has an active pull-up. See [Table 3-4](#).

0 = External  $\overline{\text{IRQ}}$  pin is disconnected from interrupt logic.

1 = External  $\overline{\text{IRQ}}$  pin is connected to interrupt logic.

IRQEN can be read and written anytime in all modes.

**DLY** — Enable Oscillator Start-up Delay on Exit from STOP

The delay time of about 4096 cycles is based on the X clock rate chosen.

0 = No stabilization delay imposed on exit from STOP mode. A stable external oscillator must be supplied.

1 = Stabilization delay is imposed before processing resumes after STOP.

DLY can be read anytime and written once in normal modes. In special modes, DLY can be read and written anytime.

	Bit 7	6	5	4	3	2	1	Bit 0
	1	1	PSEL5	PSEL4	PSEL3	PSEL2	PSEL1	0
RESET:	1	1	1	1	0	0	1	0

**HPRIO** — Highest Priority I Interrupt

**\$001F**

Write only if I mask in CCR = 1 (interrupts inhibited). Read anytime.

To give a maskable interrupt source highest priority, write the low byte of the vector address to the HPRIO register. For example, writing \$F0 to HPRIO would assign highest maskable interrupt priority to the real-time interrupt timer (\$FFF0). If an un-implemented vector address or a non-I-masked vector address (value higher than \$F2) is written, then  $\overline{\text{IRQ}}$  will be the default highest priority interrupt.

## 9.6 Resets

There are four possible sources of reset. Power-on reset (POR), and external reset on the  $\overline{\text{RESET}}$  pin share the normal reset vector. The computer operating properly (COP) reset and the clock monitor reset each has a vector. Entry into reset is asynchronous and does not require a clock but the MCU cannot sequence out of reset without a system clock.

### 9.6.1 Power-On Reset

A positive transition on  $V_{DD}$  causes a power-on reset (POR). An external voltage level detector, or other external reset circuits, are the usual source of reset in a system. The POR circuit only initializes internal circuitry during cold starts and cannot be used to force a reset as system voltage drops.

It is important to use an external low voltage reset circuit (for example: MC34064 or MC33464) to prevent power transitions or corruption of RAM or EEPROM.



## 9.6.2 External Reset

The CPU distinguishes between internal and external reset conditions by sensing whether the reset pin rises to a logic one in less than eight E-clock cycles after an internal device releases reset. When a reset condition is sensed, the  $\overline{\text{RESET}}$  pin is driven low by an internal device for about 16 E-clock cycles, then released. Eight E-clock cycles later it is sampled. If the pin is still held low, the CPU assumes that an external reset has occurred. If the pin is high, it indicates that the reset was initiated internally by either the COP system or the clock monitor.

To prevent a COP or clock monitor reset from being detected during an external reset, hold the reset pin low for at least 32 cycles. An external RC power-up delay circuit on the reset pin is not recommended as circuit charge time can cause the MCU to misinterpret the type of reset that has occurred.

## 9.6.3 COP Reset

The MCU includes a computer operating properly (COP) system to help protect against software failures. When COP is enabled, software must write \$55 and \$AA (in this order) to the COPRST register in order to keep a watchdog timer from timing out. Other instructions may be executed between these writes. A write of any value other than \$55 or \$AA or software failing to execute the sequence properly causes a COP reset to occur. In addition, windowed COP operation can be selected. In this mode, a write to the COPRST register must occur in the last 25% of the selected period. A premature write will also reset the part.

## 9.6.4 Clock Monitor Reset

If clock frequency falls below a predetermined limit when the clock monitor is enabled, a reset occurs.

## 9.7 Effects of Reset

When a reset occurs, MCU registers and control bits are changed to known start-up states, as follows.

### 9.7.1 Operating Mode and Memory Map

Operating mode and default memory mapping are determined by the states of the BKGD, MODA, and MODB pins during reset. The SMODN, MODA, and MODB bits in the MODE register reflect the status of the mode-select inputs at the rising edge of reset. Operating mode and default maps can subsequently be changed according to strictly defined rules.

### 9.7.2 Clock and Watchdog Control Logic

The COP watchdog system is enabled, with the CR[2:0] bits set for the longest duration time-out. The clock monitor is disabled. The RTIF flag is cleared and automatic hardware interrupts are masked. The rate control bits are cleared, and must be initialized before the RTI system is used. The DLY control bit is set to specify an oscillator start-up delay upon recovery from STOP mode.

### 9.7.3 Interrupts

PSEL is initialized in the HPRIO register with the value \$F2, causing the external  $\overline{\text{IRQ}}$  pin to have the highest I-bit interrupt priority. The  $\overline{\text{IRQ}}$  pin is configured for level-sensitive operation (for wired-OR systems). However, the interrupt mask bits in the CPU12 CCR are set to mask X- and I-related interrupt requests.

### 9.7.4 Parallel I/O

If the MCU comes out of reset in a single-chip mode, all ports are configured as general-purpose high-impedance inputs.

If the MCU comes out of reset in an expanded mode, port A and port B are used for the address/data bus, and port E pins are normally used to control the external bus (operation of port E pins can be affected by the PEAR register). Out of reset, port G, port H, port P, port S, port T, port CAN[7:2], port AD0 and port AD1 are all configured as general-purpose inputs.

### 9.7.5 Central Processing Unit

After reset, the CPU fetches a vector from the appropriate address, then begins executing instructions. The stack pointer and other CPU registers are indeterminate immediately after reset. The CCR X and I interrupt mask bits are set to mask any interrupt requests. The S bit is also set to inhibit the STOP instruction.

### 9.7.6 Memory

After reset, the internal register block is located from \$0000 to \$01FF, RAM is at \$0000 to \$07FF, and EEPROM is at \$0C00 to \$0FFF. In single chip mode the two FLASH EEPROM(68HC912D60)/ROM(68HC12D60) modules are located from \$1000 to \$7FFF and \$8000 to \$FFFF.

### 9.7.7 Other Resources

The enhanced capture timer (ECT), pulse width modulation timer (PWM), serial communications interfaces (SCI0 and SCI1), serial peripheral interface (SPI), Motorola Scalable CAN (MSCAN) and analog-to-digital converters (ATD0 and ATD1) are off after reset.

## 9.8 Register Stacking

Once enabled, an interrupt request can be recognized at any time after the I bit in the CCR is cleared. When an interrupt service request is recognized, the CPU responds at the completion of the instruction being executed. Interrupt latency varies according to the number of cycles

required to complete the instruction. Some of the longer instructions can be interrupted and will resume normally after servicing the interrupt.

When the CPU begins to service an interrupt, the instruction queue is cleared, the return address is calculated, and then it and the contents of the CPU registers are stacked as shown in [Table 9-2](#).

**Table 9-2. Stacking Order on Entry to Interrupts**

Memory Location	CPU Registers
SP - 2	RTN <sub>H</sub> : RTN <sub>L</sub>
SP - 4	Y <sub>H</sub> : Y <sub>L</sub>
SP - 6	X <sub>H</sub> : X <sub>L</sub>
SP - 8	B : A
SP - 9	CCR

After the CCR is stacked, the I bit (and the X bit, if an  $\overline{\text{XIRQ}}$  interrupt service request is pending) is set to prevent other interrupts from disrupting the interrupt service routine. The interrupt vector for the highest priority source that was pending at the beginning of the interrupt sequence is fetched, and execution continues at the referenced location. At the end of the interrupt service routine, an RTI instruction restores the content of all registers from information on the stack, and normal program execution resumes.

If another interrupt is pending at the end of an interrupt service routine, the register unstacking and restacking is bypassed and the vector of the interrupt is fetched.

## 9.9 Customer Information

Before disabling an interrupt using a local interrupt control bit, set the I mask bit in the CCR. Failing to do so may cause an SWI interrupt to be fetched instead of the vector for the interrupt source that was disabled.

## Section 10. ROM

### 10.1 Contents

10.2	Introduction .....	133
10.3	ROM Array .....	133

### 10.2 Introduction

The 68HC12D60 contains 60 Kbytes of read-only memory (ROM). The ROM array is arranged in a 16-bit configuration and may be read as either bytes, aligned words or misaligned words. Access time is one bus cycle for byte and aligned word access and two bus cycles for misaligned word operations.

### 10.3 ROM Array

The ROM is made of a 28K byte array mapped from \$1000 to \$7FFF and of a 32 K byte array mapped from \$8000 to \$FFFF at reset. The MAPROM bit in the MISC register allows the swapping of the two arrays. ROMON28 and ROMON32 enable or disable the ROM module.



## Section 11. I/O Ports with Key Wake-up

### 11.1 Contents

11.2	Introduction . . . . .	135
11.3	Key Wake-up and Port Registers . . . . .	136
11.4	Key Wake-Up Input Filter . . . . .	140

### 11.2 Introduction

The 112QFP 68HC(9)12D60 offers 16 additional I/O port pins with key wake-up capability on 15 of them (KWG7 is used for I<sup>2</sup>C start detect). Only two (KWG4 and KWH4) are available on the 80QFP package. All Port G and Port H pins should either be defined as outputs or have their pull-ups/downs enabled.

The key wake-up feature of the 68HC(9)12D60 issues an interrupt that will wake up the CPU when it is in the STOP or WAIT mode. Two ports are associated with the key wake-up function: port G and port H. Port G and port H wake-ups are triggered with a falling signal edge. For each pin which has an interrupt enabled, there is a path to the interrupt request signal which has no clocked devices when the part is in stop mode. This allows an active edge to bring the part out of stop.

Digital filtering is included to prevent pulses shorter than a specified value from waking the part from STOP.

An interrupt is generated when a bit in the KWIFG or KWIFH register and its corresponding KWIEG or KWIEH bit are both set. All 15 bits/pins share the same interrupt vector. Key wake-ups can be used with the pins configured as inputs or outputs.

Pull-up/down status is selected by PGUPD and PHUPD input pins: pull-up when PxUPD pin is high, pull-down when PxUPD pin is low. On 80QFP these pins are tied internally so that KWG4 is pull-up and KWH4 is pull-down.

Default register addresses, as established after reset, are indicated in the following descriptions. For information on re-mapping the register block, refer to [Operating Modes and Resource Mapping](#).

## 11.3 Key Wake-up and Port Registers

	Bit 7	6	5	4	3	2	1	Bit 0
	PG7	PG6	PG5	PG4	PG3	PG2	PG1	PG0
RESET:	—	—	—	—	—	—	—	—
Alt. Pin Function	—	KWG6	KWG5	KWG4	KWG3	KWG2	KWG1	KWG0

**PORTG** — Port G Register

**\$0028**

Read and write anytime.

	Bit 7	6	5	4	3	2	1	Bit 0
	PH7	PH6	PH5	PH4	PH3	PH2	PH1	PH0
RESET:	—	—	—	—	—	—	—	—
Alt. Pin Function	KWH7	KWH6	KWH5	KWH4	KWH3	KWH2	KWH1	KWH0

**PORTH** — Port H Register

**\$0029**

Read and write anytime.



	Bit 7	6	5	4	3	2	1	Bit 0
	DDG7	DDG6	DDG5	DDG4	DDG3	DDG2	DDG1	DDG0
RESET:	0	0	0	0	0	0	0	0

**DDRG** — Port G Data Direction Register

**\$002A**

Data direction register G is associated with port G and designates each pin as an input or output.

Read and write anytime

0 = Associated pin is an input

1 = Associated pin is an output

	Bit 7	6	5	4	3	2	1	Bit 0
	DDH7	DDH6	DDH5	DDH4	DDH3	DDH2	DDH1	DDH0
RESET:	0	0	0	0	0	0	0	0

**DDRH** — Port H Data Direction Register

**\$002B**

Data direction register H is associated with port H and designates each pin as an input or output.

Read and write anytime.

0 = Associated pin is an input

1 = Associated pin is an output

## I/O Ports with Key Wake-up

Bit 7	6	5	4	3	2	1	Bit 0
WI2CE	KWIEG6	KWIEG5	KWIEG4	KWIEG3	KWIEG2	KWIEG1	KWIEG0

RESET: 0 0 0 0 0 0 0 0

**KWIEG** — Key Wake-up Port G Interrupt Enable Register

**\$002C**

Read and write anytime.

**WI2CE** — Wake-up I<sup>2</sup>C Enable

0 = PG6 default key wake-up on falling edge

1 = I<sup>2</sup>C Start condition detection on PG7 and PG6

When WI2CE is set, PG6 and PG7 operate in wired-OR or open-drain mode.

The I<sup>2</sup>C Start condition is defined as a high to low transition of the SDA line when SCL is high. When WI2CE is set, a falling edge on PG6 (SDA) is recognized only if PG7 (SCL) is high.

Depending on WI2CE bit, KWIEG6 enables either falling edge or I<sup>2</sup>C Start condition interrupt.

**KWIEG[6:0]** — Key Wake-up Port G Interrupt Enables

0 = Interrupt for the associated bit is disabled

1 = Interrupt for the associated bit is enabled

Bit 7	6	5	4	3	2	1	Bit 0
KWIEH7	KWIEH6	KWIEH5	KWIEH4	KWIEH3	KWIEH2	KWIEH1	KWIEH0

RESET: 0 0 0 0 0 0 0 0

**KWIEH** — Key Wake-up Port H Interrupt Enable Register

**\$002D**

Read and write anytime.

**KWIEH[7:0]** — Key Wake-up Port H Interrupt Enables

0 = Interrupt for the associated bit is disabled

1 = Interrupt for the associated bit is enabled

	Bit 7	6	5	4	3	2	1	Bit 0
	0	KWIFG6	KWIFG5	KWIFG4	KWIFG3	KWIFG2	KWIFG1	KWIFG0
RESET:	0	0	0	0	0	0	0	0

**KWIFG** — Key Wake-up Port G Flag Register

**\$002E**

Each flag, except bit 6, is set by a falling edge on its associated input pin. To clear the flag, write one to the corresponding bit in KWIFG.

Read and write anytime

Bit 7 always reads zero.

**KWIFG6** — Key Wake-up Port G Flag 6

0 = Falling edge on the associated bit or I2C Start condition has not occurred

1 = Falling edge on the associated bit or I2C Start condition has occurred (an interrupt will occur if the associated enable bit is set)

Depending on WI2CE bit in KWIEG register, KWIFG6 flags either falling edge or I2C Start condition.

**KWIFG[5:0]** — Key Wake-up Port G Flags

0 = Falling edge on the associated bit has not occurred

1 = Falling edge on the associated bit has occurred (an interrupt will occur if the associated enable bit is set).

Bit 7	6	5	4	3	2	1	Bit 0
KWIFH7	KWIFH6	KWIFH5	KWIFH4	KWIFH3	KWIFH2	KWIFH1	KWIFH0

RESET:      0      0      0      0      0      0      0      0

**KWIFH** — Key Wake-up Port H Flag Register

**\$002F**

Read and write anytime.

Each flag is set by a falling edge on its associated input pin. To clear the flag, write one to the corresponding bit in KWIFH.

**KWIFH[7:0]** — Key Wake-up Port H Flags

0 = Falling edge on the associated bit has not occurred

1 = Falling edge on the associated bit has occurred (an interrupt will occur if the associated enable bit is set)

## 11.4 Key Wake-Up Input Filter

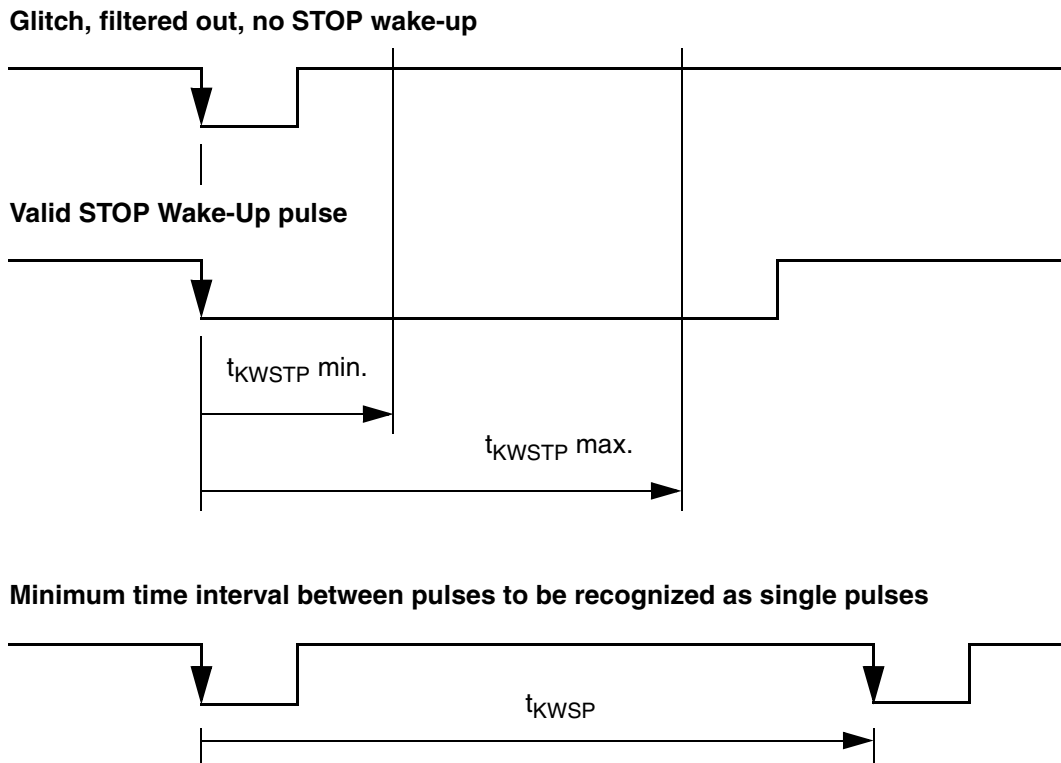
The KWU input signals are filtered by a digital filter which is active only during STOP mode. The purpose of the filter is to prevent single pulses shorter than a specified value from waking the part from STOP.

The filter is composed of an internal oscillator and a majority voting logic. The filter oscillator starts the oscillation by detecting a triggering edge on an input if the corresponding interrupt enable bit is set. The majority voting logic takes three samples of an asserted input pin at each filter oscillator period and if two samples are taken at the triggering level, the filter recognizes a valid triggering level and sets the corresponding interrupt flag. In this way the majority voting logic rejects the short non-triggering state between two incoming triggering pulses. As the filter is shared with all KWU inputs, the filter considers any pulse coming from any input pin for which the corresponding interrupt enable bit is set.

The timing specification is given for a single pulse. The time interval between the triggering edges of two following pulses should be greater than the  $t_{KWSP}$  in order to be considered as a single pulse by the filter. If

this time interval is shorter than  $t_{KWSP}$ , the majority voting logic may treat the two consecutive pulses as a single valid pulse.

The filter is shared by all the KWU pins. Hence any valid triggering level on any KWU pin is seen by the filter. The timing specification applies to the input of the filter.



**Figure 11-1. STOP Key Wake-up Filter (falling edge trigger) timing**



## Section 12. Clock Functions

### 12.1 Contents

12.2	Introduction . . . . .	143
12.3	Clock Sources . . . . .	144
12.4	Phase-Locked Loop (PLL) . . . . .	145
12.5	Acquisition and Tracking Modes . . . . .	147
12.6	Limp-Home and Fast STOP Recovery modes . . . . .	149
12.7	System Clock Frequency formulas . . . . .	167
12.8	Clock Divider Chains . . . . .	168
12.9	Computer Operating Properly (COP) . . . . .	172
12.10	Real-Time Interrupt . . . . .	173
12.11	Clock Monitor . . . . .	173
12.12	Clock Function Registers . . . . .	174

### 12.2 Introduction

Clock generation circuitry generates the internal and external E-clock signals as well as internal clock signals used by the CPU and on-chip peripherals. A clock monitor circuit, a computer operating properly (COP) watchdog circuit, and a periodic interrupt circuit are also incorporated into the 68HC(9)12D60.

### 12.3 Clock Sources

A compatible external clock signal can be applied to the EXTAL pin or the MCU can generate a clock signal using an on-chip oscillator circuit and an external crystal or ceramic resonator. The MCU uses several types of internal clock signals derived from the primary clock signal:

TxCLK clocks are used by the CPU.

ECLK and PCLK are used by the bus interfaces, SPI, PWM, ATD0 and ATD1.

MCLK is either PCLK or XCLK, and drives on-chip modules such as SCI0, SCI1 and ECT.

XCLK drives on-chip modules such as RTI, COP and restart-from-stop delay time.

SLWCLK is used as a calibration output signal.

The MSCAN module is clocked by EXTALi or SYSCLK, under control of an MSCAN bit.

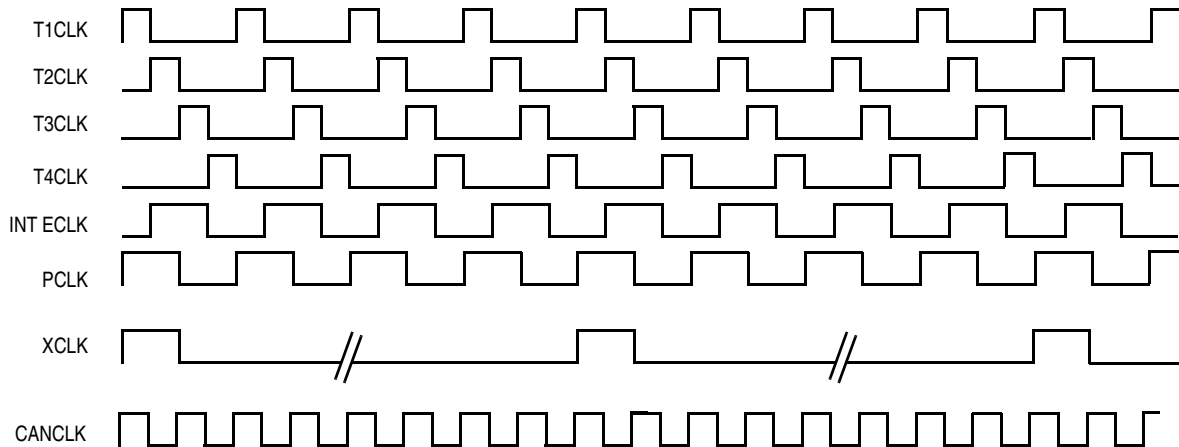
The clock monitor is clocked by EXTALi.

The BDM system is clocked by BCLK or ECLK, under control of a BDM bit.

A slow mode clock divider is included to deliver a lower clock frequency for the SCI baud rate generators, the ECT timer module, and the RTI and COP clocks. The slow clock bus frequencies divide the crystal frequency in a programmable range of 4 to 252, with steps of 4.

[Figure 12-1](#) shows some of the timing relationships. See the [Clock Divider Chains](#) section for further details.





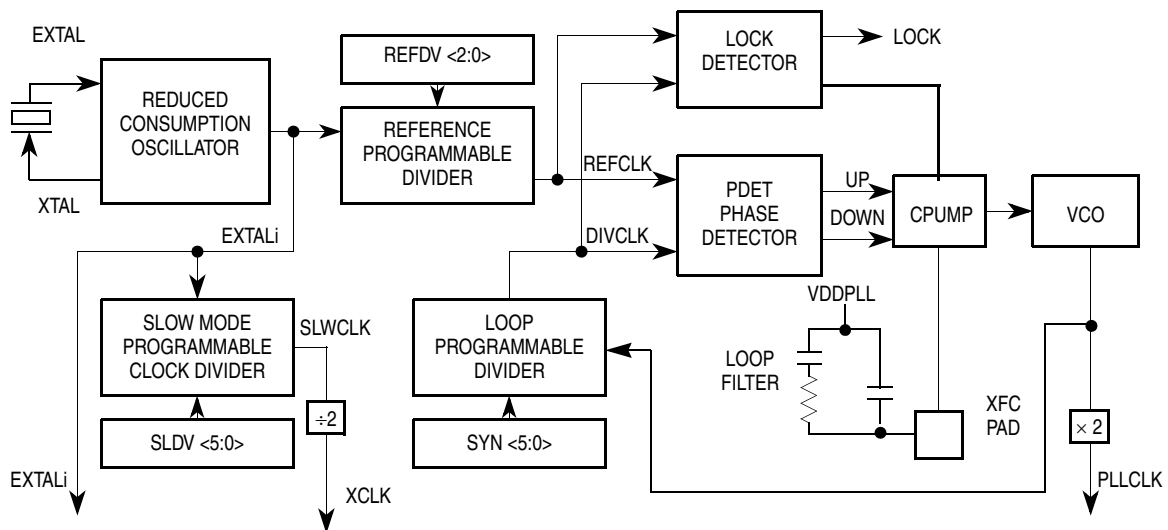
**Figure 12-1. Internal Clock Relationships**

## 12.4 Phase-Locked Loop (PLL)

The phase-locked loop (PLL) of the 68HC(9)12D60 is designed for robust operation in an Automotive environment. The allowed PLL crystal or ceramic resonator reference of 0.5 to 8MHz is selected for the wide availability of components with good stability over the automotive temperature range. Please refer to [Figure 12-6](#) in section [Clock Divider Chains](#) for an overview of system clocks.

**NOTE:** *When selecting a crystal, it is recommended to use one with the lowest possible frequency in order to minimise EMC emissions.*

An oscillator design with reduced power consumption allows for slow wait operation with a typical power supply current less than a milli-ampere. The PLL circuitry can be bypassed when the VDDPLL supply is at VSS level. In this case, the PLL module is powered down and the oscillator output transistor has a stronger transconductance for improved drive of higher frequency resonators (as the crystal frequency needs to be twice the maximum bus frequency). Refer to [Figure 3-5](#) in [Pinout and Signal Descriptions](#).



**Figure 12-2. PLL Functional Diagram**

The PLL may be used to run the MCU from a different time base than the incoming crystal value. It creates an integer multiple of a reference frequency. For increased flexibility, the crystal clock can be divided by values in a range of 1 – 8 (in unit steps) to generate the reference frequency. The PLL can multiply this reference clock in a range of 1 to 64. Although it is possible to set the divider to command a very high clock frequency, do not exceed the specified bus frequency limit for the MCU.

If the PLL is selected, it will continue to run when in WAIT mode resulting in more power consumption than normal. To take full advantage of the reduced power consumption of WAIT mode, turn off the PLL before going into WAIT. Please note that in this case the PLL stabilization time applies.

The PLL operation is suspended in STOP mode. After STOP exit followed by the stabilization time, it resumes operation at the same frequency, provided the AUTO bit is set.

A passive external loop filter must be placed on the control line (XFC pad). The filter is a second-order, low-pass filter to eliminate the VCO input ripple. Values of components in the diagram are dependent upon the desired VCO operation. See [XFC](#) description.

## 12.5 Acquisition and Tracking Modes

The lock detector compares the frequencies of the VCO feedback clock, DIVCLK, and the final reference clock, REFCLK. Therefore, the speed of the lock detector is directly proportional to the final reference frequency. The circuit determines the mode of the PLL and the lock condition based on this comparison.

The PLL filter is manually or automatically configurable into one of two operating modes:

- Acquisition mode — In acquisition mode, the filter can make large frequency corrections to the VCO. This mode is used at PLL start-up or when the PLL has suffered a severe noise hit and the VCO frequency is far off the desired frequency. This mode can also be desired in harsh environments when the leakage levels on the filter pin (XFC) can overcome the tracking currents of the PLL charge pump. When in acquisition mode, the  $\overline{ACQ}$  bit in the PLL control register is clear.
- Tracking mode — In tracking mode, the filter makes only small corrections to the frequency of the VCO. The PLL enters tracking mode when the VCO frequency is nearly correct. The PLL is automatically in tracking mode when not in acquisition mode or when the  $\overline{ACQ}$  bit is set.

The PLL can change the bandwidth or operational mode of the loop filter manually or automatically. With an identical filtering time constant, the PLL bandwidth is larger in acquisition mode than in tracking by a ratio of about 3.

In automatic bandwidth control mode (AUTO = 1), the lock detector automatically switches between acquisition and tracking modes. Automatic bandwidth control mode also is used to determine when the VCO clock, PLLCLK, is safe to use as the source for the base clock, SYSCLK. If PLL LOCK interrupt requests are enabled, the software can wait for an interrupt request and then check the LOCK bit. If CPU interrupts are disabled, software can poll the LOCK bit continuously (during PLL start-up, usually) or at periodic intervals. In either case, when the LOCK bit is set, the PLLCLK clock is safe to use as the source

for the base clock. See [Clock Divider Chains](#). If the VCO is selected as the source for the base clock and the LOCK bit is clear, the PLL has suffered a severe noise hit and the software must take appropriate action, depending on the application.

The following conditions apply when the PLL is in automatic bandwidth control mode:

- The  $\overline{ACQ}$  bit is a read-only indicator of the mode of the filter.
- The  $\overline{ACQ}$  bit is set when the VCO frequency is within a certain tolerance,  $\Delta_{\text{trk}}$ , and is cleared when the VCO frequency is out of a certain tolerance,  $\Delta_{\text{unt}}$ . See 19 Electrical Characteristics.
- The LOCK bit is a read-only indicator of the locked state of the PLL.
- The LOCK bit is set when the VCO frequency is within a certain tolerance,  $\Delta_{\text{Lock}}$ , and is cleared when the VCO frequency is out of a certain tolerance,  $\Delta_{\text{unl}}$ . See 19 Electrical Characteristics.
- CPU interrupts can occur if enabled (LOCKIE = 1) when the lock condition changes, toggling the LOCK bit.

The PLL also can operate in manual mode (AUTO = 0). All LOCK features described above are active in this mode, only the bandwidth control is disabled. Manual mode is used mainly for systems operating under harsh conditions (e.g. uncoated PCBs in automotive environments). When this is the case, the PLL is likely to remain in acquisition mode. The following conditions apply when in manual mode:

- $\overline{ACQ}$  is a writable control bit that controls the mode of the filter. Before turning on the PLL in manual mode, the  $\overline{ACQ}$  bit must be clear.
- In case tracking is desired (ACQ = 1), the software must wait a given time,  $t_{\text{acq}}$ , after turning on the PLL by setting PLLON in the PLL control register. This is to avoid switching to tracking mode too early while the XFC voltage level is still too far away from its quiescent value corresponding to the target frequency. This operation would be very detrimental to the stabilization time.

## 12.6 Limp-Home and Fast STOP Recovery modes

If the crystal frequency is not available due to a crystal failure or a long crystal start-up time, the MCU system clock can be supplied by the VCO at its minimum operating frequency,  $f_{VCOMIN}$ . This mode of operation is called Limp-Home Mode and is only available when the VDDPLL supply voltage is at VDD level (i.e. power supply for the PLL module is present). Upon power-up, the ability of the system to start in Limp-Home Mode is restricted to normal MCU modes only.

The Clock Monitor circuit (see section Clock Monitor) can detect the loss of EXTALi, the external clock input signal, regardless of whether this signal is used as the source for MCU clocks or as the PLL reference clock. The clock monitor control bits, CME and FCME, are used to enable or disable external clock detection.

A missing external clock may occur in the three following instances:

- During normal clock operation.
- At Power-On Reset.
- In the STOP exit sequence

### 12.6.1 Clock Loss during Normal Operation

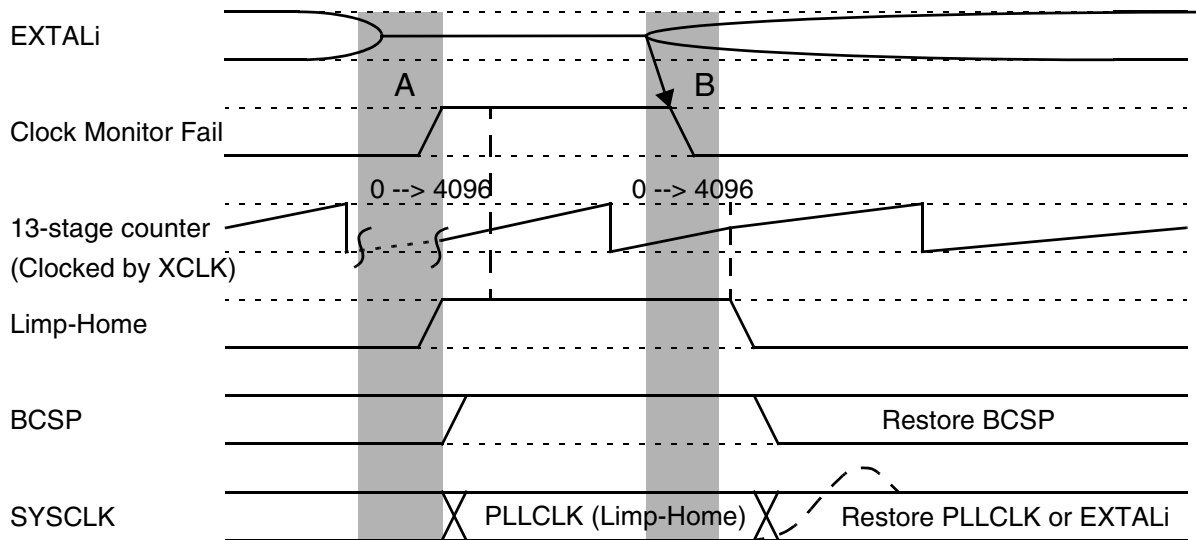
The 'no limp-home mode' bit, NOLHM, determines how the MCU responds to an external clock loss in this case.

With limp home mode disabled (NOLHM bit set) and the clock monitor enabled (CME or FCME bits set), on a loss of clock the MCU is reset via the clock monitor reset vector. A latch in the PLL control section prevents the chip exiting reset in Limp Home Mode (this is required as the NOLHM bit gets cleared by reset). Only external clock activity can bring the MCU out from this reset state. Once reset has been exited, the latch is cleared and another session, with or without Limp Home Mode enabled, can take place. This is the same behavior as standard M68HC12 circuits without PLL or operation with VDDPLL at VSS level.

With limp home mode enabled (NOLHM bit cleared) and the clock monitor enabled (CME or FCME bits set), on a loss of clock, the PLL

VCO clock at its minimum frequency,  $f_{VCOMIN}$ , is provided as the system clock, allowing the MCU to continue operating.

The MCU is said to be operating in “**limp-home**” mode with the forced VCO clock as the system clock. PLLON and BCSP (‘bus clock select PLL’) signals are forced high and the MCS (‘module clock select’) signal is forced low. The LHOME flag in the PLLFLG register is set to indicate that the MCU is running in limp-home mode. A change of this flag sets the limp-home interrupt flag, LHIF, and if enabled by the LHIE bit, the limp-home mode interrupt is requested. The Clock Monitor is enabled irrespective of CME and FCME bit settings. Module clocks to the RTI & COP (XCLK), BDM (BCLK) and ECT & SCI (MCLK) are forced to be PCLK (at  $f_{VCOMIN}$ ) and ECLK is also equal to  $f_{VCOMIN}$ . MSCAN clock select is unaffected.



**Figure 12-3. Clock Loss during Normal Operation**

The clock monitor is polled each time the 13-stage free running counter reaches a count of 4096 XCLK cycles i.e. mid-count, hence the clock status gets checked once every 8192 XCLK cycles. When the presence of an external clock is detected, the MCU exits limp-home mode, clearing the LHOME flag and setting the limp-home interrupt flag. Upon leaving limp-home mode, BCSP and MCS signals are restored to their

values before the clock loss. All clocks return to their normal settings and Clock Monitor control is returned to the CME & FCME bits. If AUTO and BCSP bits were set before the clock loss (selecting the PLL to provide a system clock) the SYSCLK ramps-up and the PLL locks at the previously selected frequency. To prevent PLL operation when the external clock frequency comes back, software should clear the BCSP bit while running in limp-home mode.

The two shaded regions **A** and **B** in [Figure 12-3](#) present a of code run away due to incorrect clocks on SYSCLK if the MCU is clocked by EXTALi and the PLL is not used.

In region **A**, there is a delay between the loss of clock and its detection by the clock monitor. When the EXTALi clock signal is disturbed, the clock generation circuitry may receive an out of spec signal and drive the CPU with irregular clocks. This may lead to code runaway.

In region **B**, as the 13-stage counter is free running, the count of 4096 may be reached when the amplitude of the EXTALi clock has not stabilized. In this case, an improper EXTALi is sent to the clock generation circuitry when limp-home mode is exited. This may also cause code runaway.

**If the MCU is clocked by the PLL, the risk of code runaway is very low, but it can still occur under certain conditions due to irregular clocks from the clock source appearing on the SYSCLK.**

**CAUTION:** *The COP watch dog should always be enabled in order to reset the MCU in case of a code runaway situation.*

**NOTE:** *It is always advisable to take additional precautions within the application software to trap such situations.*

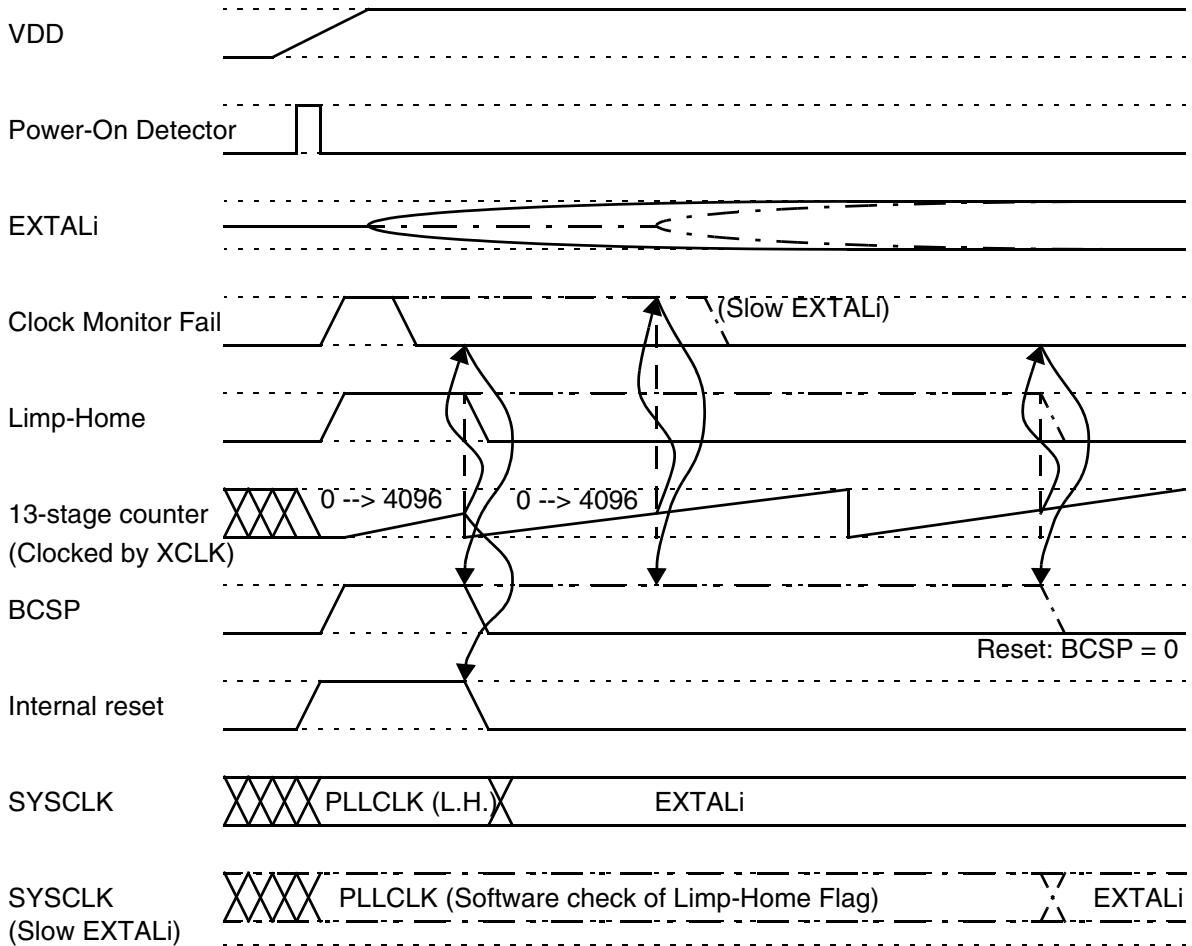
### 12.6.2 No Clock at Power-On Reset

The voltage level on VDDPLL determines how the MCU responds to an external clock loss in this case.

With the VDDPLL supply voltage at VDD level, any reset sets the Clock Monitor Enable bit (CME) and the PLLON bit and clears the NOLHM bit.

# Clock Functions

Therefore, if the MCU is powered up without an external clock, limp-home mode is entered provided the MCU is in a normal mode of operation.



**Figure 12-4. No Clock at Power-On Reset**



During this power up sequence, after the POR pulse falling edge, the VCO supplies the limp-home clock frequency to the 13-stage counter, as the BCSP output is forced high and MCS is forced low. XCLK, BCLK and MCLK are forced to be PCLK, which is supplied by the VCO at  $f_{VCOMIN}$ . The initial period taken for the 13-stage counter to reach 4096 defines the internal reset period.

If the clock monitor indicates the presence of an external clock during the internal reset period, limp-home mode is de-asserted and the 13-stage counter is then driven by EXTALi clock. After the 13-stage counter reaches a count of 4096 XCLK cycles, the internal reset is released, the 13-stage counter is reset and the MCU exits reset normally using EXTALi clock.

However, if the crystal start-up time is longer than the initial count of 4096 XCLK cycles, or in the absence of an external clock, the MCU will leave the reset state in limp-home mode. The LHOME flag is set and LHIF limp-home interrupt request is set, to indicate it is not operating at the desired frequency. Then after yet another 4096 XCLK cycles followed regularly by 8192 XCLK cycles (corresponding to the 13-stage counter timing out), a check of the clock monitor status is performed. When the presence of an external clock is detected limp-home mode is exited generating a limp-home interrupt if enabled.

**CAUTION:** *The clock monitor circuit can be misled by the EXTALi clock into reporting a good signal before it has fully stabilised. Under these conditions improper EXTALi clock cycles can occur on SYSCLK. This may lead to a code runaway. To ensure that this situation does not occur, the external Reset period should be longer than the oscillator stabilisation time - this is an application dependent parameter.*

With the VDDPLL supply voltage at VSS level, the PLL module and hence limp-home mode are disabled, the device will remain effectively in a static state whilst there is no activity on EXTALi. The internal reset period and MCU operation will execute only on EXTALi clock.

**NOTE:** *The external clock signal must stabilise within the initial 4096 reset counter cycles.*

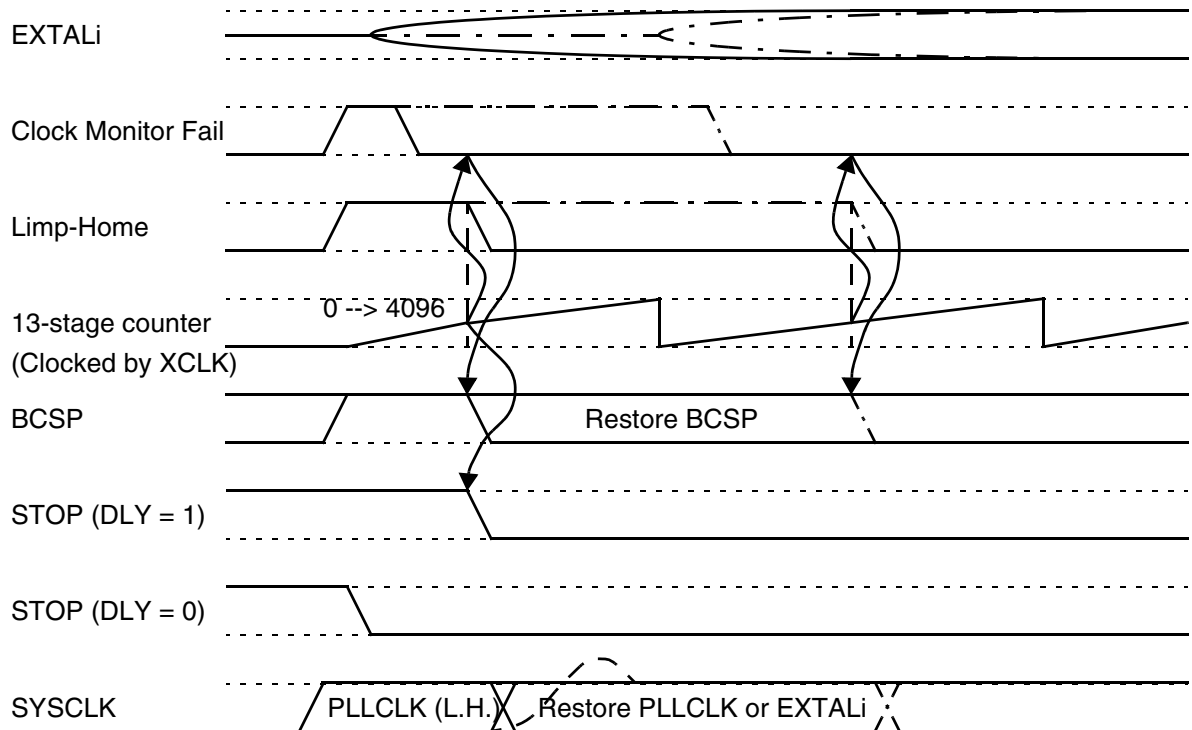
### 12.6.3 STOP Exit and Fast STOP Recovery

Stop mode is entered when a STOP instruction is executed. Recovery from STOP depends primarily on the state of the three status bits NOLHM, CME & DLY.

The DLY bit controls the duration of the waiting period between the actual exit for some key blocks (e.g. clock monitor, clock generators) and the effective exit from stop for all the rest of the MCU. DLY=1 enables the 13-stage counter to generate a 4096 count delay. DLY=0 selects no delay. As the XCLK is derived from the slow mode divider, the value in the SLOW register modifies the actual delay time.

**NOTE:** *DLY=0 is only recommended when there is a good signal available at the EXTAL pin (e.g. an external square wave source).*

STOP mode is exited with an external reset, an external interrupt from IRQ or XIRQ, a Key Wake-Up interrupt from port J or port H, or an MSCAN Wake-Up interrupt.



**Figure 12-5. STOP Exit and Fast STOP Recovery**

#### 12.6.4 STOP exit without Limp Home mode, clock monitor disabled

**(NOLHM=1, CME=0, DLY=X)**

If Limp home mode is disabled ( $V_{DDPLL}=V_{SS}$  or NOLHM bit set) and the CME (or FCME) bit is cleared, the MCU goes into STOP mode when a STOP instruction is executed.

If EXTALi clock is present then exit from STOP will occur normally using this clock. Under this condition, DLY should always be set to allow the crystal to stabilise and minimise the risk of code runaway. With DLY=1 execution resumes after a delay of 4096 XCLK cycles.

**NOTE:** *The external clock signal should stabilise within the 4096 reset counter cycles. Use of DLY=0 is not recommended due to this requirement.*

### 12.6.5 Executing the STOP instruction without Limp Home mode, clock monitor enabled

**(NOLHM=1, CME=1, DLY=X)**

If the NOLHM bit and the CME (or FCME) bits are set, a clock monitor failure is detected when a STOP instruction is executed and the MCU resets via the clock monitor reset vector.

### 12.6.6 STOP exit in Limp Home mode with Delay

**(NOLHM=0, CME=X, DLY=1)**

If the NOLHM bit is cleared, then the CME (or FCME) bit is masked when a STOP instruction is executed to prevent a clock monitor failure. When coming out of STOP mode, the MCU goes into limp-home mode where CME and FCME signals are asserted.

When using a crystal oscillator, a normal STOP exit sequence requires the DLY bit to be set to allow for the crystal stabilization period.

With the 13-stage counter clocked by the VCO (at  $f_{VCOMIN}$ ), following a delay of 4096 XCLK cycles at the limp-home frequency, if the clock monitor indicates the presence of an external clock, the limp-home mode is de-asserted and the MCU exits STOP normally using EXTALi clock. Where the crystal start-up time is longer than the initial count of 4096 XCLK cycles, or in the absence of an external clock, the MCU recovers from STOP following the 4096 count in limp-home mode with both the LHOME flag set and the LHIF limp-home interrupt request set to indicate it is not operating at the desired frequency. Each time the 13-stage counter reaches a count of 4096 XCLK cycles, a check of the clock monitor status is performed.

When the presence of an external clock is detected, limp-home mode is exited and the LHOME flag is cleared. This sets the limp-home interrupt flag and if enabled by the LHIE bit, the limp-home mode interrupt is requested.

**CAUTION:** *The clock monitor circuit can be misled by EXTALi clock into reporting a good signal before it has fully stabilised. Under these conditions, improper EXTALi clock cycles can occur on SYSCLK. This may lead to a code runaway.*

### 12.6.7 STOP exit in Limp Home mode without Delay (Fast Stop Recovery)

**(NOLHM=0, CME=X, DLY=0)**

Fast STOP recovery refers to any exit from STOP using DLY=0.

If the NOLHM bit is cleared, then the CME (or FCME) bit is masked when a STOP instruction is executed to prevent a clock monitor failure. When coming out of STOP mode, the MCU goes into limp-home mode where CME and FCME signals are asserted.

When using a crystal oscillator, it is possible to exit STOP with the DLY bit cleared. In this case, STOP is de-asserted without delay and the MCU will execute software in limp-home mode, giving the crystal oscillator time to stabilise.

**CAUTION:** *This mode is not recommended since the risk of the clock monitor detecting incorrect clocks is high.*

Each time the 13-stage counter reaches a count of 4096 XCLK cycles (every 8192 cycles), a check of the clock monitor status is performed. If the clock monitor indicates the presence of an external clock limp-home mode is de-asserted, the LHOME flag is cleared and the limp-home interrupt flag is set. Upon leaving limp-home mode, BCSP and MCS are restored to their values before the loss of clock, and all clocks return to their previous frequencies. If AUTO and BCSP were set before the clock loss, the SYSCLK ramps-up and the PLL locks at the previously selected frequency.

To prevent PLL operation when the external clock frequency comes back, the software should clear the BCSP bit while running in limp-home mode.

When using an external clock, i.e. a square wave source, it is possible to exit STOP with the DLY bit cleared. In this case the LHOME flag is never set and STOP is de-asserted without delay.

### 12.6.8 Pseudo-STOP

Pseudo-STOP is a low power mode similar to STOP where the external oscillator is allowed to run (at reduced amplitude) whilst the rest of the part is in STOP. This increases the current consumption over STOP mode by the amount of current in the oscillator, but reduces wear and mechanical stress on the crystal.

If the PSTP bit in the PLLCR register is set, the MCU goes into Pseudo-STOP mode when a STOP instruction is executed.

Pseudo-STOP mode is exited the same as STOP with an external reset, an external interrupt from IRQ or XIRQ, a Key Wake-Up interrupt from port J or port H, or an MSCAN Wake-Up interrupt.

The effect of the DLY bit is the same as noted above in [STOP Exit and Fast STOP Recovery](#).

### 12.6.9 Pseudo-STOP exit in Limp Home mode with Delay

**(NOLHM=0, CME=X, DLY=1)**

When coming out of Pseudo-STOP mode with the NOLHM bit cleared and the DLY bit set, the MCU goes into limp-home mode (regardless of the state of the CME or FCME bits).

The VCO supplies the limp-home clock frequency to the 13-stage counter (XCLK). The BCSP output is forced high and MCS is forced low. After the 13-stage counter reaches a count of 4096 XCLK cycles, a check of the clock monitor is performed and as the crystal oscillator was kept running due to the Pseudo-stop mode, the MCU exits STOP normally, using the EXTALi clock. In the case where a crystal failure occurred during pseudo-stop, then the MCU exits STOP using the limp home clock ( $f_{VCOMIN}$ ) with both the LHOME flag set and the LHIF limp-home interrupt request set to indicate it is not operating at the desired frequency. Each time the 13-stage counter reaches a count of 4096 XCLK cycles, a check of the clock monitor is performed. If the clock monitor indicates the presence of an external clock, limp-home mode is de-asserted, the LHOME flag is cleared and the LHIF limp-home

interrupt request is set to indicate a return to normal operation using EXTALi clock.

#### 12.6.10 Pseudo-STOP exit in Limp Home mode without Delay (Fast Stop Recovery)

**(NOLHM=0, CME=X, DLY=0)**

If Pseudo-STOP is exited with the NOLHM bit set to 0 and the DLY bit is cleared then the exit from Pseudo-STOP is accomplished without delay as in Fast STOP recovery.

**CAUTION:** *Where Pseudo-STOP recovers using the Limp Home Clock the VCO - which has been held in STOP - must be restarted in order to supply the limp home frequency. This restart, which occurs at a high frequency and ramps toward the limp home frequency, is almost immediately supplied to the CPU before it may have reached the steady state frequency. It is possible that the initial clock frequency may be high enough to cause the CPU to function incorrectly with a resultant risk of code runaway.*

#### 12.6.11 Pseudo-STOP exit without Limp Home mode, clock monitor enabled

**(NOLHM=1, CME=1, DLY=X)**

If the NOLHM bit is set and the CME (or FCME) bits are set, a clock monitor failure is detected when a STOP instruction is executed and the MCU resets via the clock monitor reset vector.

#### 12.6.12 Pseudo-STOP exit without Limp Home mode, clock monitor disabled

**(NOLHM=1, CME=0, DLY=1)**

If NOLHM is set to 1 and the CME and FCME bits are cleared, the limp home clock is not used. In this mode, crystal activity is the only method by which the device may recover from Pseudo-STOP. The device will start execution with the EXTALi clock following 4096 XCLK cycles.

**(NOLHM=1, CME=0, DLY=0)**

If NOLHM is set to 1 and the CME and FCME bits are cleared, the limp home clock is not used. In this mode, crystal activity is the only method by which the device may recover from Pseudo-STOP. The device will start execution with the EXTALi clock following 16 XCLK cycles.

**CAUTION:** *Due to switching of the clock this configuration is not recommended.*

### 12.6.13 Summary of STOP and pseudo-STOP Mode Exit Conditions

[Table 12-1](#) and [Table 12-2](#) summarise the exit conditions from STOP and pseudo-STOP modes using Interrupt, Key-interrupt and XIRQ.

A short RESET pulse should not be used to exit stop or pseudo-STOP mode because Limp Home mode is automatically entered after RESET (when  $V_{DDPLL}=V_{DD}$ ). The RESET wakeup pulse must be longer than the oscillator startup time (as in power on reset) in order to remove the risk of code runaway.



**Table 12-1. Summary of STOP Mode Exit Conditions**

Mode	Conditions	Summary
STOP exit without Limp Home mode, clock monitor disabled	NOLHM=1 CME=0 DLY=X	Oscillator must be stable within 4096 XCLK cycles. XCLK can be modified by SLOW divider register. Use of DLY=0 only recommended with external clock.
Executing the STOP instruction without Limp Home mode, clock monitor enabled	NOLHM=1 CME=1 DLY=X	When a STOP instruction is executed the MCU resets via the clock monitor reset vector.
STOP exit in Limp Home mode with Delay	NOLHM=0 CME=X DLY=1	Oscillator must be stable within 4096 $f_{VCOMIN}$ cycles or there is a possibility of code runaway as the clock monitor circuit can be misled by EXTALi clock into reporting a good signal before it has fully stabilised
STOP exit in Limp Home mode without Delay (Fast Stop Recovery)	NOLHM=0 CME=X DLY=0	This mode is only recommended for use with an external clock source.

**Table 12-2. Summary of Pseudo STOP Mode Exit Conditions**

Mode	Conditions	Summary
Pseudo-STOP exit in Limp Home mode with Delay	NOLHM=0 CME=X DLY=1	CPU exits stop in limp home mode and oscillator running. If the oscillator fails during pseudo-STOP and then recovers there is a possibility of code runaway as the clock monitor circuit can be misled by EXTALi clock into reporting a good signal before it has fully stabilised
Pseudo-STOP exit in Limp Home mode without Delay (Fast Stop Recovery)	NOLHM=0 CME=X DLY=0	This mode is not recommended as it is possible that the initial VCO clock frequency may be high enough to cause code runaway.
Pseudo-STOP exit without Limp Home mode, clock monitor enabled	NOLHM=1 CME=1 DLY=X	When a STOP instruction is executed the MCU resets via the clock monitor reset vector.
Pseudo-STOP exit without Limp Home mode, clock monitor disabled, with Delay	NOLHM=1 CME=0 DLY=1	Oscillator starts operation following 4096 XCLK cycles (actual controlled by SLOW mode divider).
Pseudo-STOP exit without Limp Home mode, clock monitor disabled, without Delay	NOLHM=1 CME=0 DLY=0	This mode is only recommended for use with an external clock source.

## 12.6.14 PLL Register Descriptions

	Bit 7	6	5	4	3	2	1	Bit 0
	0	0	SYN5	SYN4	SYN3	SYN2	SYN1	SYN0
RESET:	0	0	0	0	0	0	0	0

**SYNR** — Synthesizer Register

**\$0038**

Read anytime, write anytime, except when BCSP = 1 (PLL selected as bus clock).

If the PLL is on, the count in the loop divider (SYNR) register effectively multiplies up the bus frequency from the PLL reference frequency by SYNR + 1. Internally, SYSCCLK runs at twice the bus frequency. Caution should be used not to exceed the maximum rated operating frequency for the CPU.

	Bit 7	6	5	4	3	2	1	Bit 0
	0	0	0	0	0	REFDV2	REFDV1	REFDV0
RESET:	0	0	0	0	0	0	0	0

**REFDV** — Reference Divider Register

**\$0039**

Read anytime, write anytime, except when BCSP = 1.

The reference divider bits provides a finer granularity for the PLL multiplier steps. The reference frequency is divided by REFDV + 1.

	Bit 7	6	5	4	3	2	1	Bit 0
	TSTOUT7	TSTOUT6	TSTOUT5	TSTOUT4	TSTOUT3	TSTOUT2	TSTOUT1	TSTOUT0
RESET:	0	0	0	0	0	0	0	0

**CGTFLG** — Clock Generator Test Register

**\$003A**

Always reads zero, except in test modes.

	Bit 7	6	5	4	3	2	1	Bit 0
	LOCKIF	LOCK	0	0	0	0	LHIF	LHOME
RESET:	0	0	0	0	0	0	0	0

**PLLFLG** — PLL Flags

**\$003B**

Read anytime, refer to each bit for write conditions.

**LOCKIF** — PLL Lock Interrupt Flag

0 = No change in LOCK bit.

1 = LOCK condition has changed, either from a locked state to an unlocked state or vice versa.

To clear the flag, write one to this bit in PLLFLG. Cleared in limp-home mode.

**LOCK** — Locked Phase Lock Loop Circuit

Regardless of the bandwidth control mode (automatic or manual):

0 = PLL VCO is not within the desired tolerance of the target frequency.

1 = After the phase lock loop circuit is turned on, indicates the PLL VCO is within the desired tolerance of the target frequency.

Write has no effect on LOCK bit. This bit is cleared in limp-home mode as the lock detector cannot operate without the reference frequency.

**LHIF** — Limp-Home Interrupt Flag

0 = No change in LHOME bit.

1 = LHOME condition has changed, either entered or exited limp-home mode.

To clear the flag, write one to this bit in PLLFLG.

**LHOME** — Limp-Home Mode Status

0 = MCU is operating normally, with EXTALi clock available for generating clocks or as PLL reference.

1 = Loss of reference clock. CGM delivers PLL VCO limp-home frequency to the MCU.

For Limp-Home mode, see [Limp-Home and Fast STOP Recovery modes](#).

# Clock Functions

	Bit 7	6	5	4	3	2	1	Bit 0
	LOCKIE	PLLON	AUTO	$\overline{ACQ}$	0	PSTP	LHIE	NOLHM
RESET:	0	—(1)	1	0	0	0	0	—(2)

## PLLCR — PLL Control Register

**\$003C**

1. Set when VDDPLL power supply is high. Forced to 0 when VDDPLL is low.
2. Cleared when VDDPLL power supply is high. Forced to 1 when VDDPLL is low.

Read and write anytime. Exceptions are listed below for each bit.

### LOCKIE — PLL LOCK Interrupt Enable

- 0 = PLL LOCK interrupt is disabled
- 1 = PLL LOCK interrupt is enabled

Forced to 0 when VDDPLL=0.

### PLLON — Phase Lock Loop On

- 0 = Turns the PLL off.
- 1 = Turns on the phase lock loop circuit. If AUTO is set, the PLL will lock automatically.

Cannot be cleared when BCSP = 1 (PLL selected as bus clock).  
 Forced to 0 when VDDPLL is at VSS level. In limp-home mode, the output of PLLON is forced to 1, but the PLLON bit reads the latched value.

### AUTO — Automatic Bandwidth Control

- 0 = Automatic Mode Control is disabled and the PLL is under software control, using  $\overline{ACQ}$  bit.
- 1 = Automatic Mode Control is enabled.  $\overline{ACQ}$  bit is read only.

Automatic bandwidth control selects either the high bandwidth (acquisition) mode or the low bandwidth (tracking) mode depending on how close to the desired frequency the VCO is running. See [Electrical Specifications](#).

$\overline{ACQ}$  — Not in Acquisition

If AUTO = 1 ( $\overline{ACQ}$  is Read Only)

0 = PLL VCO is not within the desired tolerance of the target frequency. The loop filter is in high bandwidth, acquisition mode.

1 = After the phase lock loop circuit is turned on, indicates the PLL VCO is within the desired tolerance of the target frequency. The loop filter is in low bandwidth, tracking mode.

If AUTO = 0

0 = High bandwidth PLL loop selected

1 = Low bandwidth PLL loop selected

PSTP — Pseudo-STOP Enable

0 = Pseudo-STOP oscillator mode is disabled

1 = Pseudo-STOP oscillator mode is enabled

In Pseudo-STOP mode, the oscillator is still running while the MCU is maintained in STOP mode. This allows for a faster STOP recovery and reduces the mechanical stress and aging of the resonator in case frequent STOP conditions at the expense of a slightly increased power consumption.

LHIE — Limp-Home Interrupt Enable

0 = Limp-Home interrupt is disabled

1 = Limp-Home interrupt is enabled

Forced to 0 when VDDPLL is at VSS level.

NOLHM — No Limp-Home Mode

0 = Loss of reference clock forces the MCU in limp-home mode.

1 = Loss of reference clock causes standard Clock Monitor reset.

Read anytime; Normal modes: write once; Special modes: write anytime. Forced to 1 when VDDPLL is at VSS level.

# Clock Functions

	Bit 7	6	5	4	3	2	1	Bit 0
	0	BCSP	BCSS	0	0	MCS	0	0
RESET:	0	0	0	0	0	0	0	0

**CLKSEL** — Clock Generator Clock select Register

**\$003D**

Read and write anytime. Exceptions are listed below for each bit.

BCSP and BCSS bits determine the clock used by the main system including the CPU and buses.

**BCSP** — Bus Clock Select PLL

- 0 = SYSCLK is derived from the crystal clock or from SLWCLK.
- 1 = SYSCLK source is the PLL.

Cannot be set when PLLON = 0. In limp-home mode, the output of BCSP is forced to 1, but the BCSP bit reads the latched value.

**BCSS** — Bus Clock Select Slow

- 0 = SYSCLK is derived from the crystal clock EXTALi.
- 1 = SYSCLK source is the Slow clock SLWCLK.

This bit has no effect when BCSP is set.

**MCS** — Module Clock Select

- 0 = M clock is the same as PCLK.
- 1 = M clock is derived from Slow clock SLWCLK.

This bit determines the clock used by the ECT module and the baud rate generators of the SCIs. In limp-home mode, the output of MCS is forced to 0, but the MCS bit reads the latched value.

	Bit 7	6	5	4	3	2	1	Bit 0
	0	0	SLDV5	SLDV4	SLDV3	SLDV2	SLDV1	SLDV0
RESET:	0	0	0	0	0	0	0	0

**SLOW** — Slow mode Divider Register

**\$003E**

Read and write anytime.

A write to this register changes the SLWCLK frequency with minimum delay (less than one SLWCLK cycle), thus allowing immediate tune-up of the performance versus power consumption for the modules using this clock. The frequency divide ratio is 2 times (SLOW), hence the divide range is 2 to 126 (not on first pass products). When SLOW = 0, the divider is bypassed. The generation of E, P and M clocks further divides SLWCLK by 2. Hence, the final ratio of Bus to EXTALi Frequency is programmable to 2, 4, 8, 12, 16, 20, ..., 252, by steps of 4. SLWCLK is a 50% duty cycle signal.

## 12.7 System Clock Frequency formulas

See [Figure 12-6](#):

$$\text{SLWCLK} = \text{EXTALi} / ( 2 \times \text{SLOW} ) \qquad \text{SLOW} = 1,2,..63$$

$$\text{SLWCLK} = \text{EXTALi} \qquad \text{SLOW} = 0$$

$$\text{PLLCLK} = 2 \times \text{EXTALi} \times (\text{SYNR} + 1) / (\text{REFDV} + 1)$$

$$\text{ECLK} = \text{SYSCLK} / 2$$

$$\text{XCLK} = \text{SLWCLK} / 2$$

$$\text{PCLK} = \text{SYSCLK} / 2$$

$$\text{BCLK}^{(1)} = \text{EXTALi} / 2$$

Boolean equations:

1. If SYSCLK is slower than EXTALi (BCSS=1, BCSP=0, SLOW>0), BCLK becomes ECLK.

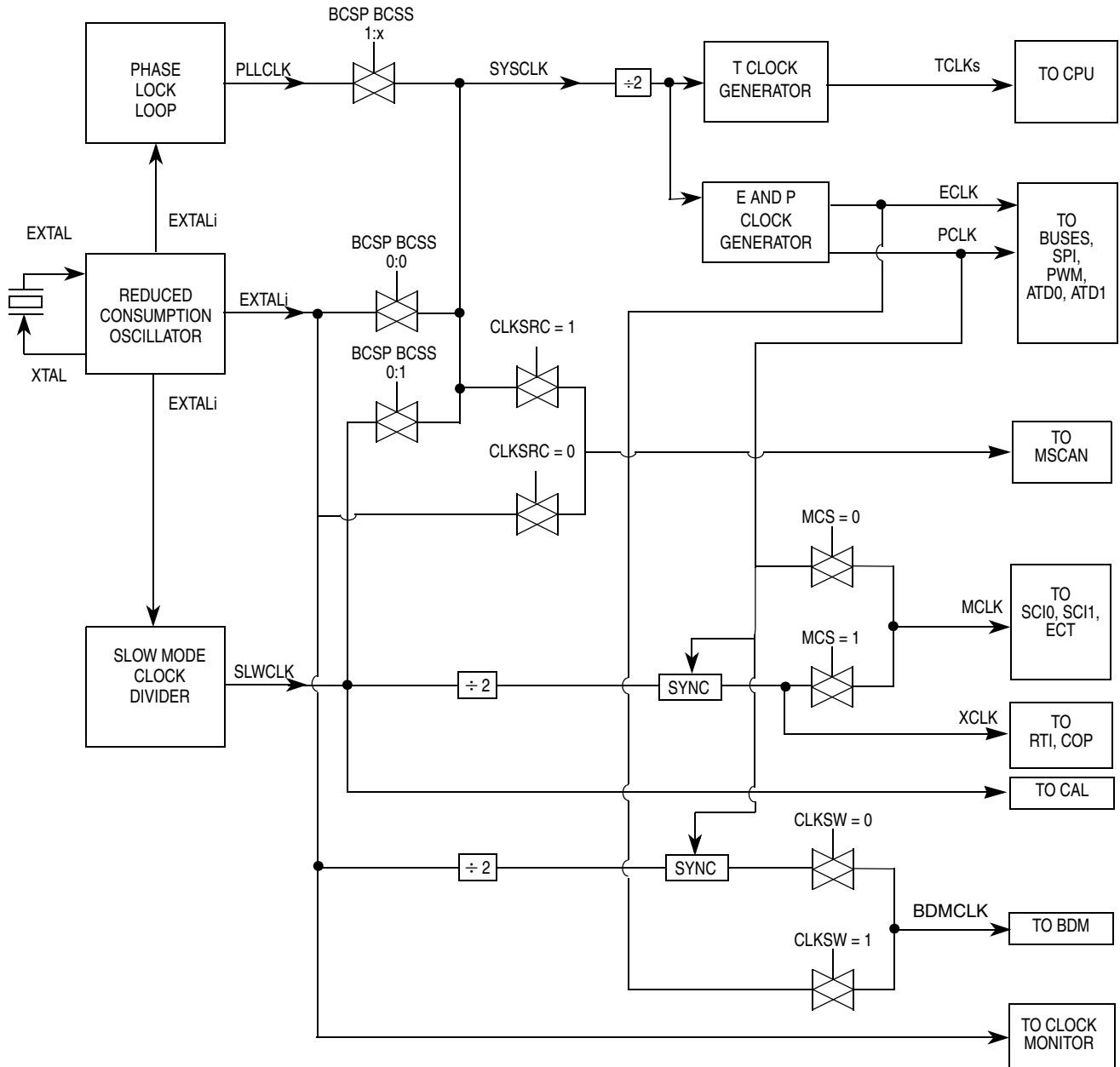
$$\text{SYSCLK} = (\text{BCSP} \& \text{PLLCLK}) \mid (\overline{\text{BCSP}} \& \overline{\text{BCSS}} \& \text{EXTALi}) \mid (\overline{\text{BCSP}} \& \text{BCSS} \& \text{SLWCLK})$$
$$\text{MCLK} = (\text{PCLK} \& \overline{\text{MCS}}) \mid (\text{XCLK} \& \text{MCS})$$
$$\text{MSCAN system} = (\text{EXTALi} \& \overline{\text{CLKSRC}}) \mid (\text{SYSCLK} \& \text{CLKSRC})$$
$$\text{BDM system} = (\text{BCLK} \& \overline{\text{CLKSW}}) \mid (\text{ECLK} \& \text{CLKSW})$$

**NOTE:** *During limp-home mode PCLK, ECLK, BCLK, MCLK and XCLK are supplied by VCO (PLLCLK).*

## 12.8 Clock Divider Chains

[Figure 12-6](#), [Figure 12-7](#), [Figure 12-8](#), and [Figure 12-9](#) summarize the clock divider chains for the various peripherals on the 68HC(9)12D60.





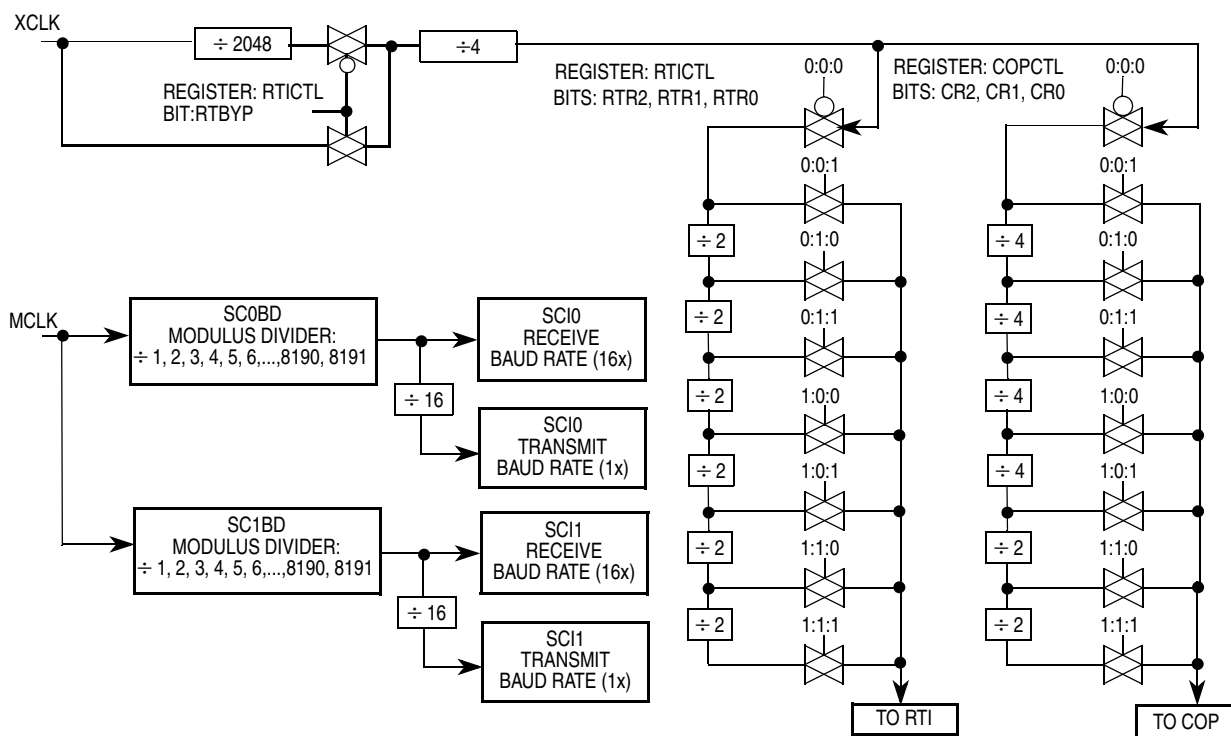
**Figure 12-6. Clock Generation Chain**

Bus clock select bits BCSP and BCSS in the clock select register (CLKSEL) determine which clock drives SYSCLK for the main system including the CPU and buses. BCSS has no effect if BCSP is set. During

# Clock Functions

the transition, the clock select output will be held low and all CPU activity will cease until the transition is complete.

The Module Clock Select bit MCS determines the clock used by the ECT module and the baud rate generators of the SCIs. In limp-home mode, the output of MCS is forced to 0, but the MCS bit reads the latched value. It allows normal operation of the serial and timer subsystems at a fixed reference frequency while allowing the CPU to operate at a higher, variable frequency.



**Figure 12-7. Clock Chain for SCI0, SCI1, RTI, COP**

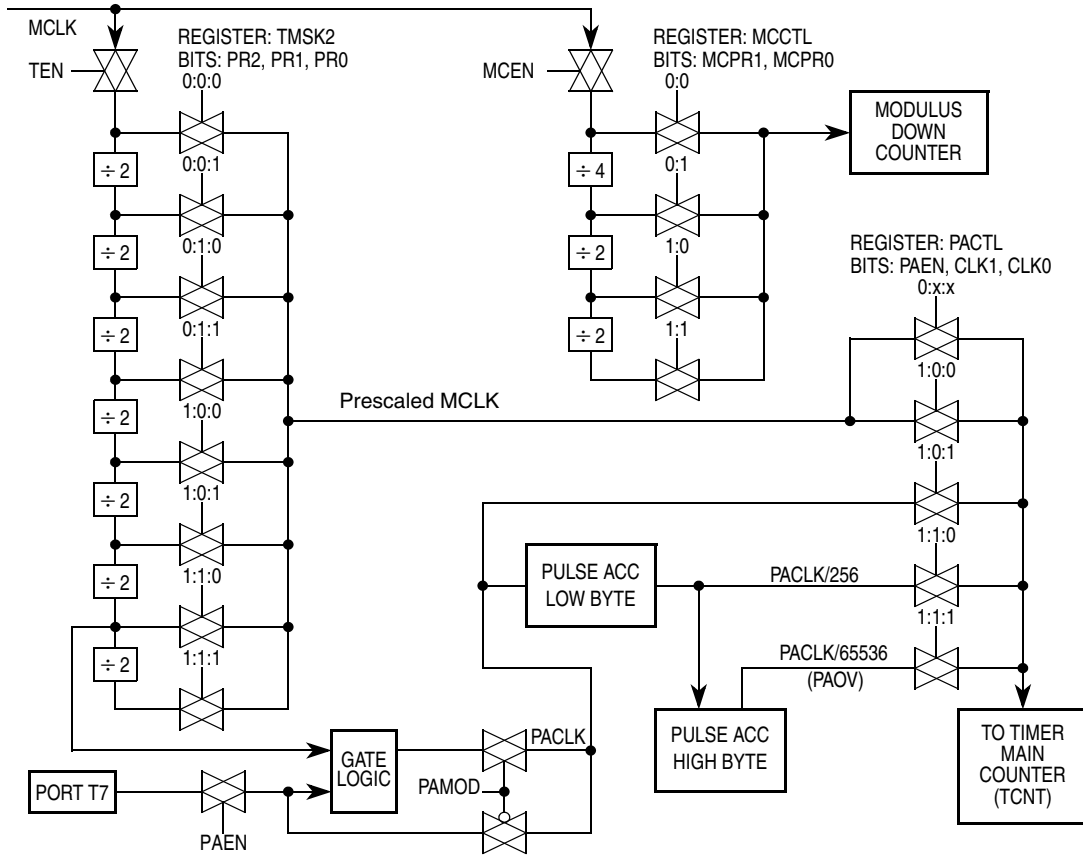


Figure 12-8. Clock Chain for ECT

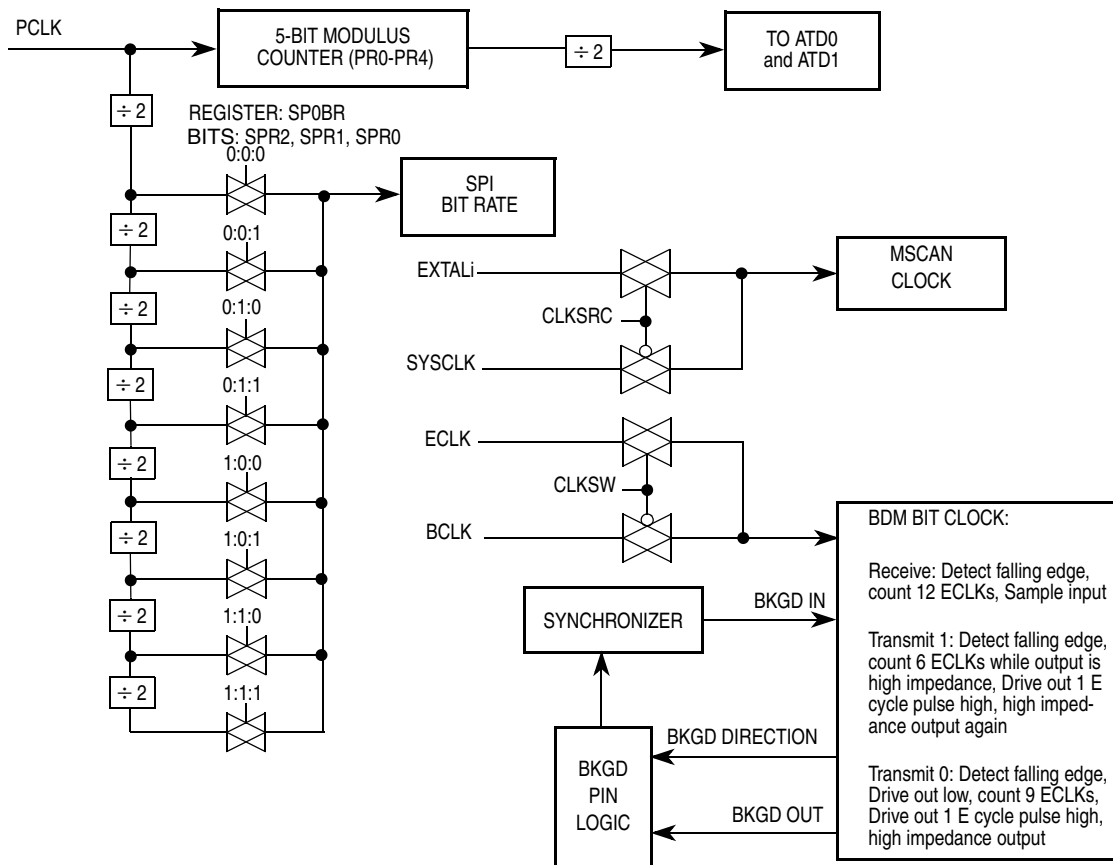


Figure 12-9. Clock Chain for MSCAN, SPI, ATD0, ATD1 and BDM

## 12.9 Computer Operating Properly (COP)

The COP or watchdog timer is an added check that a program is running and sequencing properly. When the COP is being used, software is responsible for keeping a free running watchdog timer from timing out. If the watchdog timer times out it is an indication that the software is no longer being executed in the intended sequence; thus a system reset is initiated. Three control bits allow selection of seven COP time-out periods. When COP is enabled, sometime during the selected period the program must write \$55 and \$AA (in this order) to the COPRST register. If the program fails to do this the part will reset. If any value other than \$55 or \$AA is written, the part is reset.

In addition, windowed COP operation can be selected. In this mode, writes to the COPRST register must occur in the last 25% of the selected period. A premature write will also reset the part.

## 12.10 Real-Time Interrupt

There is a real time (periodic) interrupt available to the user. This interrupt will occur at one of seven selected rates. An interrupt flag and an interrupt enable bit are associated with this function. There are three bits for the rate select.

## 12.11 Clock Monitor

The clock monitor circuit is based on an internal resistor-capacitor (RC) time delay. If no EXTALi clock edges are detected within this RC time delay, the clock monitor can optionally generate a system reset. The clock monitor function is enabled/disabled by the CME control bit in the COPCTL register. This time-out is based on an RC delay so that the clock monitor can operate without any EXTALi clock.

Clock monitor time-outs are shown in [Table 12-3](#). The corresponding EXTALi clock period with an ideal 50% duty cycle is twice this time-out value.

**Table 12-3. Clock Monitor Time-Outs**

Supply	Range
5 V +/- 10%	2–20 $\mu$ S

## 12.12 Clock Function Registers

All register addresses shown reflect the reset state. Registers may be mapped to any 2K byte space.

	Bit 7	6	5	4	3	2	1	Bit 0
	RTIE	RSWAI	RSBCK	Reserved	RTBYP	RTR2	RTR1	RTR0
RESET:	0	0	0	0	0	0	0	0

**RTICTL** — Real-Time Interrupt Control Register

**\$0014**

**RTIE** — Real Time Interrupt Enable

Read and write anytime.

0 = Interrupt requests from RTI are disabled.

1 = Interrupt will be requested whenever RTIF is set.

**RSWAI** — RTI and COP Stop While in Wait

Write once in normal modes, anytime in special modes. Read anytime.

0 = Allows the RTI and COP to continue running in wait.

1 = Disables both the RTI and COP whenever the part goes into Wait.

**RSBCK** — RTI and COP Stop While in Background Debug Mode

Write once in normal modes, anytime in special modes. Read anytime.

0 = Allows the RTI and COP to continue running while in background mode.

1 = Disables both the RTI and COP when the part is in background mode. This is useful for emulation.

**RTBYP** — Real Time Interrupt Divider Chain Bypass

Write not allowed in normal modes, anytime in special modes. Read anytime.

0 = Divider chain functions normally.

1 = Divider chain is bypassed, allows faster testing (the divider chain is normally XCLK divided by  $2^{13}$ , when bypassed becomes XCLK divided by 4).

RTR2, RTR1, RTR0 — Real-Time Interrupt Rate Select

Read and write anytime.

Rate select for real-time interrupt. The clock used for this module is the XCLK.

**Table 12-4. Real Time Interrupt Rates**

RTR2	RTR1	RTR0	Divide X By:	Time-Out Period X = 125 KHz	Time-Out Period X = 500 KHz	Time-Out Period X = 2.0 MHz	Time-Out Period X = 8.0 MHz
0	0	0	OFF	OFF	OFF	OFF	OFF
0	0	1	2 <sup>13</sup>	65.536 ms	16.384 ms	4.096 ms	1.024 ms
0	1	0	2 <sup>14</sup>	131.72 ms	32.768 ms	8.196 ms	2.048 ms
0	1	1	2 <sup>15</sup>	263.44 ms	65.536 ms	16.384 ms	4.096 ms
1	0	0	2 <sup>16</sup>	526.88 ms	131.72 ms	32.768 ms	8.196 ms
1	0	1	2 <sup>17</sup>	1.05 s	263.44 ms	65.536 ms	16.384 ms
1	1	0	2 <sup>18</sup>	2.11 s	526.88 ms	131.72 ms	32.768 ms
1	1	1	2 <sup>19</sup>	4.22 s	1.05 s	263.44 ms	65.536 ms

Bit 7	6	5	4	3	2	1	Bit 0
RTIF	0	0	0	0	0	0	0
RESET:	0	0	0	0	0	0	0

**RTIFLG** — Real Time Interrupt Flag Register

**\$0015**

**RTIF** — Real Time Interrupt Flag

This bit is cleared automatically by a write to this register with this bit set.

0 = Time-out has not yet occurred.

1 = Set when the time-out period is met.

## Clock Functions

	Bit 7	6	5	4	3	2	1	Bit 0	
	CME	FCME	FCMCOP	WCOP	DISR	CR2	CR1	CR0	
RESET:	0/1	0	0	0	0	1	1	1	Normal
RESET:	0/1	0	0	0	1	1	1	1	Special

**COPCTL** — COP Control Register

**\$0016**

### CME — Clock Monitor Enable

Read and write anytime.

If FCME is set, this bit has no meaning nor effect.

0 = Clock monitor is disabled. Slow clocks and stop instruction may be used.

1 = Slow or stopped clocks (including the stop instruction) will cause a clock reset sequence or limp-home mode. See [Limp-Home and Fast STOP Recovery modes](#).

On reset

CME is 1 if VDDPLL is high

CME is 0 if VDDPLL is low.

**NOTE:** *The VDDPLL-dependent reset operation is not implemented on first pass products.*

*In this case the state of CME on reset is 0.*

### FCME — Force Clock Monitor Enable

Write once in normal modes, anytime in special modes. Read anytime.

In normal modes, when this bit is set, the clock monitor function cannot be disabled until a reset occurs.

0 = Clock monitor follows the state of the CME bit.

1 = Slow or stopped clocks will cause a clock reset sequence or limp-home mode.

See [Limp-Home and Fast STOP Recovery modes](#).



### FCMCOP — Force Clock Monitor Reset or COP Watchdog Reset

Writes are not allowed in normal modes, anytime in special modes.  
Read anytime.

If DISR is set, this bit has no effect.

0 = Normal operation.

1 = A clock monitor failure reset or a COP failure reset is forced depending on the state of CME and if COP is enabled.

CME	COP enabled	Forced reset
0	0	none
0	1	COP failure
1	0	Clock monitor failure
1	1	Both <sup>(1)</sup>

1. Highest priority interrupt vector is serviced.

### WCOP — Window COP mode

Write once in normal modes, anytime in special modes. Read anytime.

0 = Normal COP operation

1 = Window COP operation

When set, a write to the COPRST register must occur in the last 25% of the selected period. A premature write will also reset the part. As long as all writes occur during this window, \$55 can be written as often as desired. Once \$AA is written the time-out logic restarts and the user must wait until the next window before writing to COPRST. Please note, there is a fixed time uncertainty about the exact COP counter state when reset, as the initial prescale clock divider in the RTI section is not cleared when the COP counter is cleared. This means the effective window is reduced by this uncertainty. [Table 12-5](#) below shows the exact duration of this window for the seven available COP rates.

**Table 12-5. COP Watchdog Rates**

CR2	CR1	CR0	Divide X clock by	8.0 MHz X clock. Time-out	Window COP enabled:		
					Window start (1)	Window end	Effective Window (2)
0	0	0	OFF	OFF	OFF	OFF	OFF
0	0	1	$2^{13}$	1.024 ms -0/+0.256 ms	0.768 ms	0.768 ms	0 % (3)
0	1	0	$2^{15}$	4.096 ms -0/+0.256 ms	3.072 ms	3.840 ms	18.8 %
0	1	1	$2^{17}$	16.384 ms -0/+0.256 ms	12.288 ms	16.128 ms	23.4 %
1	0	0	$2^{19}$	65.536 ms -0/+1.024 ms	49.152 ms	64.512 ms	23.4 %
1	0	1	$2^{21}$	262.144 ms -0/+1.024 ms	196.608 ms	261.120 ms	24.6 %
1	1	0	$2^{22}$	524.288 ms -0/+1.024 ms	393.216 ms	523.264 ms	24.8 %
1	1	1	$2^{23}$	1.048576 ms -0/+1.024 ms	786.432 ms	1.047552 ms	24.9 %

1. Time for writing \$55 following previous COP restart of time-out logic due to writing \$AA.

2. Please refer to WCOP bit description above.

3. Window COP cannot be used at this rate.

### DISR — Disable Resets from COP Watchdog and Clock Monitor

Writes are not allowed in normal modes, anytime in special modes.

Read anytime.

0 = Normal operation.

1 = Regardless of other control bit states, COP and clock monitor will not generate a system reset.

### CR2, CR1, CR0 — COP Watchdog Timer Rate select bits

These bits select the COP time-out rate. The clock used for this module is the XCLK.

Write once in normal modes, anytime in special modes. Read anytime.

	Bit 7	6	5	4	3	2	1	Bit 0
	Bit 7	6	5	4	3	2	1	Bit 0
RESET:	0	0	0	0	0	0	0	0

**COPRST** — Arm/Reset COP Timer Register

**\$0017**

Always reads \$00.

Writing \$55 to this address is the first step of the COP watchdog sequence.

Writing \$AA to this address is the second step of the COP watchdog sequence. Other instructions may be executed between these writes but both must be completed in the correct order prior to time-out to avoid a watchdog reset. Writing anything other than \$55 or \$AA causes a COP reset to occur.



## Section 13. Pulse Width Modulator

### 13.1 Contents

13.2	Introduction . . . . .	181
13.3	PWM Register Description . . . . .	184
13.4	PWM Boundary Cases . . . . .	196

### 13.2 Introduction

The pulse-width modulator (PWM) subsystem provides four independent 8-bit PWM waveforms or two 16-bit PWM waveforms or a combination of one 16-bit and two 8-bit PWM waveforms. Each waveform channel has a programmable period and a programmable duty-cycle as well as a dedicated counter. A flexible clock select scheme allows four different clock sources to be used with the counters. Each of the modulators can create independent, continuous waveforms with software-selectable duty rates from 0 percent to 100 percent. The PWM outputs can be programmed as left-aligned outputs or center-aligned outputs.

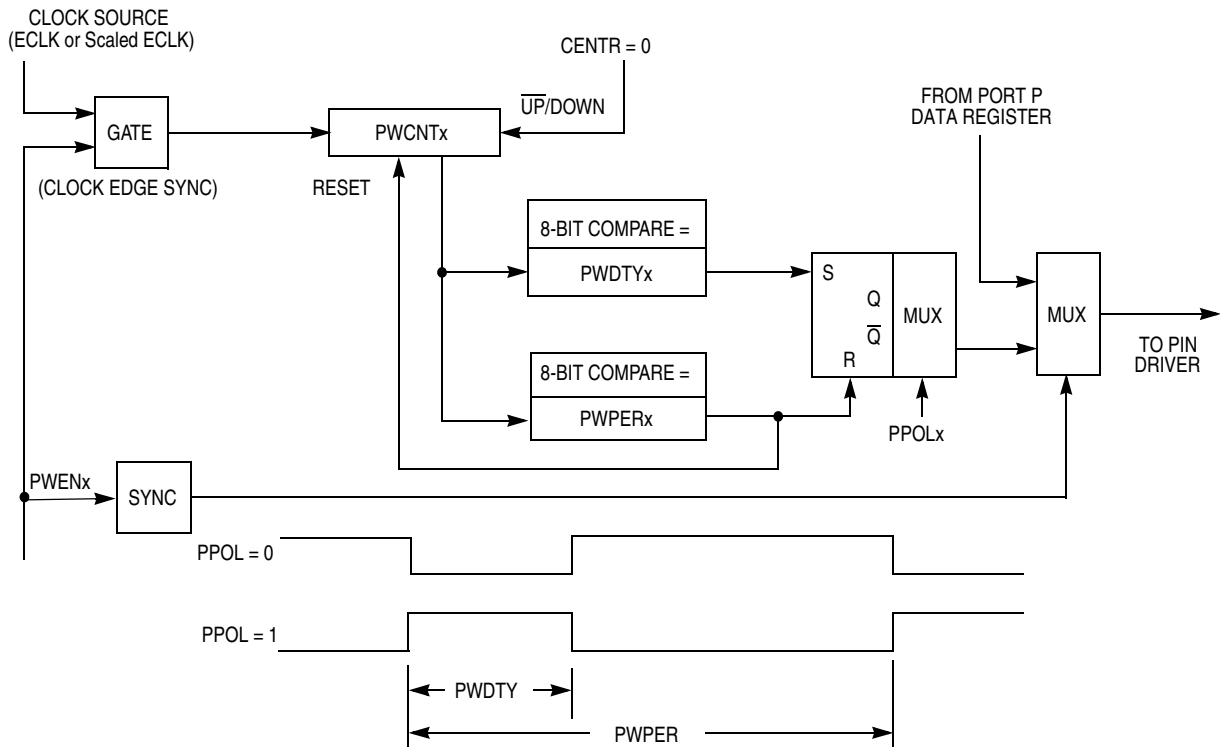
The period and duty registers are double buffered so that if they change while the channel is enabled, the change will not take effect until the counter rolls over or the channel is disabled. If the channel is not enabled, then writes to the period and/or duty register will go directly to the latches as well as the buffer, thus ensuring that the PWM output will always be either the old waveform or the new waveform, not some variation in between.

A change in duty or period can be forced into immediate effect by writing the new value to the duty and/or period registers and then writing to the counter. This causes the counter to reset and the new duty and/or period values to be latched. In addition, since the counter is readable it is

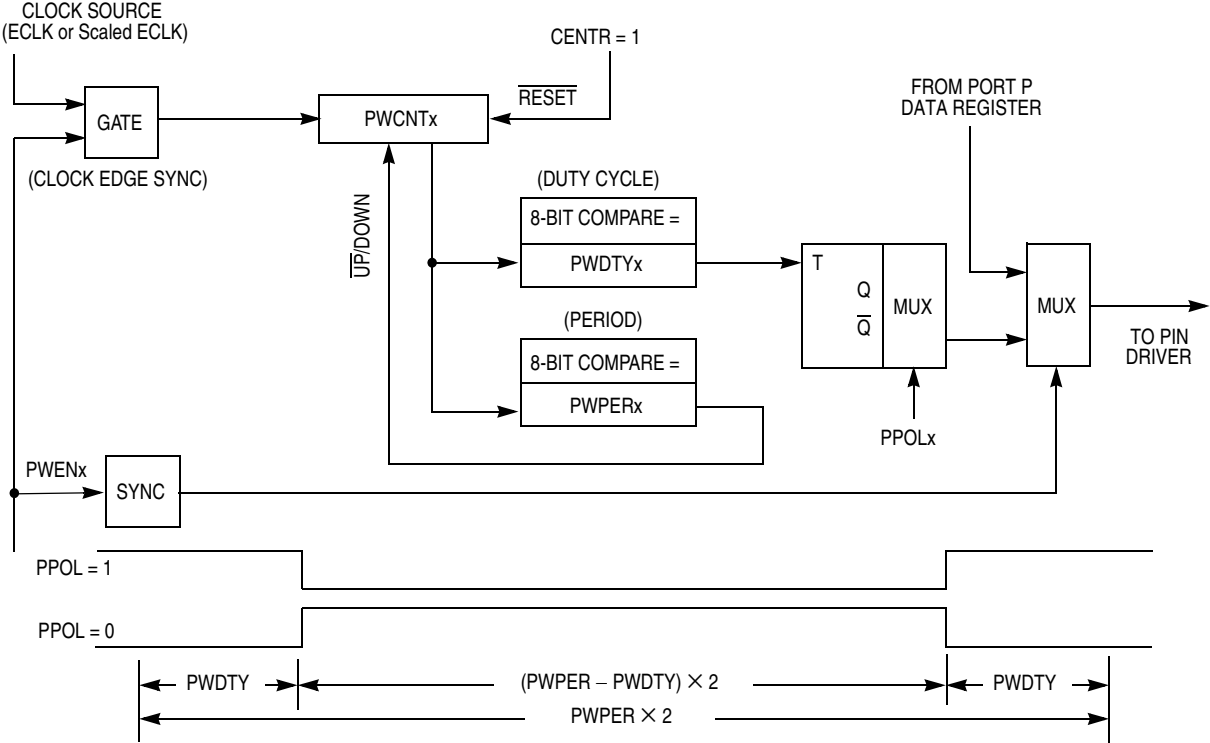
# Pulse Width Modulator

possible to know where the count is with respect to the duty value and software can be used to make adjustments by turning the enable bit off and on.

The four PWM channel outputs share general-purpose port P pins. Enabling PWM pins takes precedence over the general-purpose port. When PWM channels are not in use, the port pins may be used for discrete input/output.



**Figure 13-1. Block Diagram of PWM Left-Aligned Output Channel**



**Figure 13-2. Block Diagram of PWM Center-Aligned Output Channel**





### CON23 — Concatenate PWM Channels 2 and 3

When concatenated, channel 2 becomes the high-order byte and channel 3 becomes the low-order byte. Channel 2 output pin is used as the output for this 16-bit PWM (bit 2 of port P). Channel 3 clock-select control bits determines the clock source. Channel 3 output pin becomes a general purpose I/O.

0 = Channels 2 and 3 are separate 8-bit PWMs.

1 = Channels 2 and 3 are concatenated to create one 16-bit PWM channel.

### CON01 — Concatenate PWM Channels 0 and 1

When concatenated, channel 0 becomes the high-order byte and channel 1 becomes the low-order byte. Channel 0 output pin is used as the output for this 16-bit PWM (bit 0 of port P). Channel 1 clock-select control bits determine the clock source. Channel 1 output pin becomes a general purpose I/O.

0 = Channels 0 and 1 are separate 8-bit PWMs.

1 = Channels 0 and 1 are concatenated to create one 16-bit PWM channel.

### PCKA2 – PCKA0 — Prescaler for Clock A

Clock A is one of two clock sources which may be used for channels 0 and 1. These three bits determine the rate of clock A, as shown in [Table 13-1](#).

## PCKB2 – PCKB0 — Prescaler for Clock B

Clock B is one of two clock sources which may be used for channels 2 and 3. These three bits determine the rate of clock B, as shown in [Table 13-1](#).

**Table 13-1. Clock A and Clock B Prescaler**

PCKA2 (PCKB2)	PCKA1 (PCKB1)	PCKA0 (PCKB0)	Value of Clock A (B)
0	0	0	P
0	0	1	$P \div 2$
0	1	0	$P \div 4$
0	1	1	$P \div 8$
1	0	0	$P \div 16$
1	0	1	$P \div 32$
1	1	0	$P \div 64$
1	1	1	$P \div 128$

Bit 7	6	5	4	3	2	1	Bit 0
PCLK3	PCLK2	PCLK1	PCLK0	PPOL3	PPOL2	PPOL1	PPOL0
RESET: 0	0	0	0	0	0	0	0

**PWPOL** — PWM Clock Select and Polarity

**\$0041**

Read and write anytime.

### PCLK3 — PWM Channel 3 Clock Select

- 0 = Clock B is the clock source for channel 3.
- 1 = Clock S1 is the clock source for channel 3.

### PCLK2 — PWM Channel 2 Clock Select

- 0 = Clock B is the clock source for channel 2.
- 1 = Clock S1 is the clock source for channel 2.

### PCLK1 — PWM Channel 1 Clock Select

- 0 = Clock A is the clock source for channel 1.
- 1 = Clock S0 is the clock source for channel 1.

**PCLK0 — PWM Channel 0 Clock Select**

0 = Clock A is the clock source for channel 0.

1 = Clock S0 is the clock source for channel 0.

If a clock select is changed while a PWM signal is being generated, a truncated or stretched pulse may occur during the transition.

The following four bits apply in left-aligned mode only:

**PPOL3 — PWM Channel 3 Polarity**

0 = Channel 3 output is low at the beginning of the period; high when the duty count is reached.

1 = Channel 3 output is high at the beginning of the period; low when the duty count is reached.

**PPOL2 — PWM Channel 2 Polarity**

0 = Channel 2 output is low at the beginning of the period; high when the duty count is reached.

1 = Channel 2 output is high at the beginning of the period; low when the duty count is reached.

**PPOL1 — PWM Channel 1 Polarity**

0 = Channel 1 output is low at the beginning of the period; high when the duty count is reached.

1 = Channel 1 output is high at the beginning of the period; low when the duty count is reached.

**PPOL0 — PWM Channel 0 Polarity**

0 = Channel 0 output is low at the beginning of the period; high when the duty count is reached.

1 = Channel 0 output is high at the beginning of the period; low when the duty count is reached.

Depending on the polarity bit, the duty registers may contain the count of either the high time or the low time. If the polarity bit is zero and left alignment is selected, the duty registers contain a count of the low time. If the polarity bit is one, the duty registers contain a count of the high time.

# Pulse Width Modulator

Bit 7	6	5	4	3	2	1	Bit 0
0	0	0	0	PWEN3	PWEN2	PWEN1	PWEN0

RESET: 0 0 0 0 0 0 0 0

**PWEN** — PWM Enable

**\$0042**

Setting any of the PWENx bits causes the associated port P line to become an output regardless of the state of the associated data direction register (DDRP) bit. This does not change the state of the data direction bit. When PWENx returns to zero, the data direction bit controls I/O direction. On the front end of the PWM channel, the scaler clock is enabled to the PWM circuit by the PWENx enable bit being high. When all four PWM channels are disabled, the prescaler counter shuts off to save power. There is an edge-synchronizing gate circuit to guarantee that the clock will only be enabled or disabled at an edge.

Read and write anytime.

## PWEN3 — PWM Channel 3 Enable

The pulse modulated signal will be available at port P, bit 3 when its clock source begins its next cycle.

0 = Channel 3 is disabled.

1 = Channel 3 is enabled.

## PWEN2 — PWM Channel 2 Enable

The pulse modulated signal will be available at port P, bit 2 when its clock source begins its next cycle.

0 = Channel 2 is disabled.

1 = Channel 2 is enabled.

## PWEN1 — PWM Channel 1 Enable

The pulse modulated signal will be available at port P, bit 1 when its clock source begins its next cycle.

0 = Channel 1 is disabled.

1 = Channel 1 is enabled.

### PWEN0 — PWM Channel 0 Enable

The pulse modulated signal will be available at port P, bit 0 when its clock source begins its next cycle.

0 = Channel 0 is disabled.

1 = Channel 0 is enabled.

	Bit 7	6	5	4	3	2	1	Bit 0
	0	Bit 6	5	4	3	2	1	Bit 0
RESET:	0	0	0	0	0	0	0	0

### PWPRES — PWM Prescale Counter

**\$0043**

PWPRES is a free-running 7-bit counter. Read anytime. Write only in special mode (SMOD = 1).

	Bit 7	6	5	4	3	2	1	Bit 0
	Bit 7	6	5	4	3	2	1	Bit 0
RESET:	0	0	0	0	0	0	0	0

### PWSCAL0 — PWM Scale Register 0

**\$0044**

Read and write anytime. A write will cause the scaler counter PWSCNT0 to load the PWSCAL0 value unless in special mode with DISCAL = 1 in the PWTST register.

PWM channels 0 and 1 can select clock S0 (scaled) as its input clock by setting the control bit PCLK0 and PCLK1 respectively. Clock S0 is generated by dividing clock A by the value in the PWSCAL0 register + 1 and dividing again by two. When PWSCAL0 = \$FF, clock A is divided by 256 then divided by two to generate clock S0.

# Pulse Width Modulator



RESET: 0 0 0 0 0 0 0 0

**PWSCNT0** — PWM Scale Counter 0 Value

**\$0045**

PWSCNT0 is a down-counter that, upon reaching \$00, loads the value of PWSCAL0. Read any time.



RESET: 0 0 0 0 0 0 0 0

**PWSCAL1** — PWM Scale Register 1

**\$0046**

Read and write anytime. A write will cause the scaler counter PWSCNT1 to load the PWSCAL1 value unless in special mode with DISCAL = 1 in the PWTST register.

PWM channels 2 and 3 can select clock S1 (scaled) as its input clock by setting the control bit PCLK2 and PCLK3 respectively. Clock S1 is generated by dividing clock B by the value in the PWSCAL1 register + 1 and dividing again by two. When PWSCAL1 = \$FF, clock B is divided by 256 then divided by two to generate clock S1.



RESET: 0 0 0 0 0 0 0 0

**PWSCNT1** — PWM Scale Counter 1 Value

**\$0047**

PWSCNT1 is a down-counter that, upon reaching \$00, loads the value of PWSCAL1. Read any time.

	Bit 7	6	5	4	3	2	1	Bit 0	
<b>PWCNT0</b>	Bit 7	6	5	4	3	2	1	Bit 0	<b>\$0048</b>
<b>PWCNT1</b>	Bit 7	6	5	4	3	2	1	Bit 0	<b>\$0049</b>
<b>PWCNT2</b>	Bit 7	6	5	4	3	2	1	Bit 0	<b>\$004A</b>
<b>PWCNT3</b>	Bit 7	6	5	4	3	2	1	Bit 0	<b>\$004B</b>
RESET:	0	0	0	0	0	0	0	0	

**PWCNTx** — PWM Channel Counters

Read and write anytime. A write will cause the PWM counter to reset to \$00.

In special mode, if DISCR = 1, a write does not reset the PWM counter.

The PWM counters are not reset when PWM channels are disabled. The counters must be reset prior to a new enable.

Each counter may be read any time without affecting the count or the operation of the corresponding PWM channel. Writes to a counter cause the counter to be reset to \$00 and force an immediate load of both duty and period registers with new values. To avoid a truncated PWM period, write to a counter while the counter is disabled. In left-aligned output mode, resetting the counter and starting the waveform output is controlled by a match between the period register and the value in the counter. In center-aligned output mode the counters operate as up/down counters, where a match in period changes the counter direction. The duty register changes the state of the output during the period to determine the duty.

When a channel is enabled, the associated PWM counter starts at the count in the PWCNTx register using the clock selected for that channel.

In special mode, when DISCP = 1 and configured for left-aligned output, a match of period does not reset the associated PWM counter.

# Pulse Width Modulator

	Bit 7	6	5	4	3	2	1	Bit 0	
<b>PWPER0</b>	Bit 7	6	5	4	3	2	1	Bit 0	<b>\$004C</b>
<b>PWPER1</b>	Bit 7	6	5	4	3	2	1	Bit 0	<b>\$004D</b>
<b>PWPER2</b>	Bit 7	6	5	4	3	2	1	Bit 0	<b>\$004E</b>
<b>PWPER3</b>	Bit 7	6	5	4	3	2	1	Bit 0	<b>\$004F</b>
RESET:	1	1	1	1	1	1	1	1	

**PWPERx** — PWM Channel Period Registers

Read and write anytime.

The value in the period register determines the period of the associated PWM channel. If written while the channel is enabled, the new value will not take effect until the existing period terminates, forcing the counter to reset. The new period is then latched and is used until a new period value is written. Reading this register returns the most recent value written. To start a new period immediately, write the new period value and then write the counter forcing a new period to start with the new period value.

$$\begin{aligned} \text{Period} &= \text{Channel-Clock-Period} \times (\text{PWPER} + 1) && (\text{CENTR} = 0) \\ \text{Period} &= \text{Channel-Clock-Period} \times (2 \times \text{PWPER}) && (\text{CENTR} = 1) \end{aligned}$$

	Bit 7	6	5	4	3	2	1	Bit 0	
<b>PWDY0</b>	Bit 7	6	5	4	3	2	1	Bit 0	<b>\$0050</b>
<b>PWDY1</b>	Bit 7	6	5	4	3	2	1	Bit 0	<b>\$0051</b>
<b>PWDY2</b>	Bit 7	6	5	4	3	2	1	Bit 0	<b>\$0052</b>
<b>PWDY3</b>	Bit 7	6	5	4	3	2	1	Bit 0	<b>\$0053</b>
RESET:	1	1	1	1	1	1	1	1	

**PWDYx** — PWM Channel Duty Registers

Read and write anytime.



The value in each duty register determines the duty of the associated PWM channel. When the duty value is equal to the counter value, the output changes state. If the register is written while the channel is enabled, the new value is held in a buffer until the counter rolls over or the channel is disabled. Reading this register returns the most recent value written.

If the duty register is greater than or equal to the value in the period register, there will be no duty change in state. If the duty register is set to \$FFF the output will always be in the state which would normally be the state opposite the PPOLx value.

Left-Aligned-Output Mode (CENTR = 0):

$$\text{Duty cycle} = [(PWDTYx + 1) / (PWPERx + 1)] \times 100\% \quad (\text{PPOLx} = 1)$$

$$\text{Duty cycle} = [(PWPERx - PWDTYx) / (PWPERx + 1)] \times 100\% \quad (\text{PPOLx} = 0)$$

Center-Aligned-Output Mode (CENTR = 1):

$$\text{Duty cycle} = [(PWPERx - PWDTYx) / PWPERx] \times 100\% \quad (\text{PPOLx} = 0)$$

$$\text{Duty cycle} = [PWDTYx / PWPERx] \times 100\% \quad (\text{PPOLx} = 1)$$

	Bit 7	6	5	4	3	2	1	Bit 0
	0	0	0	PSWAI	CENTR	RDPP	PUPP	PSBCK
RESET:	0	0	0	0	0	0	0	0

**PWCTL** — PWM Control Register

**\$0054**

Read and write anytime.

**PSWAI** — PWM Halts while in Wait Mode

0 = Allows PWM main clock generator to continue while in wait mode.

1 = Halt PWM main clock generator when the part is in wait mode.

**CENTR** — Center-Aligned Output Mode

To avoid irregularities in the PWM output mode, write the CENTR bit only when PWM channels are disabled.

0 = PWM channels operate in left-aligned output mode

1 = PWM channels operate in center-aligned output mode

## Pulse Width Modulator

RDPP — Reduced Drive of Port P

0 = All port P output pins have normal drive capability.

1 = All port P output pins have reduced drive capability.

PUPP — Pull-Up Port P Enable

0 = All port P pins have an active pull-up device disabled.

1 = All port P pins have an active pull-up device enabled.

PSBCK — PWM Stops while in Background Mode

0 = Allows PWM to continue while in background mode.

1 = Disable PWM input clock when the part is in background mode.

	Bit 7	6	5	4	3	2	1	Bit 0
	DISCR	DISCP	DISCAL	0	0	0	0	0
RESET:	0	0	0	0	0	0	0	0

**PWTST** — PWM Special Mode Register (“Test”)

**\$0055**

Read anytime but write only in special mode (SMODN = 0). These bits are available only in special mode and are reset in normal mode.

DISCR — Disable Reset of Channel Counter on Write to Channel Counter

0 = Normal operation. Write to PWM channel counter will reset channel counter.

1 = Write to PWM channel counter does not reset channel counter.

DISCP — Disable Compare Count Period

0 = Normal operation

1 = In left-aligned output mode, match of period does not reset the associated PWM counter register.

DISCAL — Disable Load of Scale-Counters on Write to the Associated Scale-Registers

0 = Normal operation

1 = Write to PWSCAL0 and PWSCAL1 does not load scale counters

	Bit 7	6	5	4	3	2	1	Bit 0
	PP7	PP6	PP5	PP4	PP3	PP2	PP1	PP0
PWM	–	–	–	–	PWM3	PWM2	PWM1	PWM0
RESET:	–	–	–	–	–	–	–	–

**PORTP** — Port P Data Register

**\$0056**

PORTP can be read anytime.

PWM functions share port P pins 3 to 0 and take precedence over the general-purpose port when enabled.

When configured as input, a read will return the pin level.

When configured as output, a read will return the latched output data. A write will drive associated pins only if configured for output and the corresponding PWM channel is not enabled.

After reset, all pins are general-purpose, high-impedance inputs.

	Bit 7	6	5	4	3	2	1	Bit 0
	DDP7	DDP6	DDP5	DDP4	DDP3	DDP2	DDP1	DDP0
RESET:	0	0	0	0	0	0	0	0

**DDRP** — Port P Data Direction Register

**\$0057**

DDRP determines pin direction of port P when used for general-purpose I/O.

Read and write anytime.

DDRP[7:0] — Data Direction Port P pin 7-0

0 = I/O pin configured as high impedance input

1 = I/O pin configured for output.

## 13.4 PWM Boundary Cases

The boundary conditions for the PWM channel duty registers and the PWM channel period registers cause these results:

**Table 13-2. PWM Left-Aligned Boundary Conditions**

PWDTYx	PWPERx	PPOLx	Output
\$FF	>\$00	1	Low
\$FF	>\$00	0	High
≥PWPERx	–	1	High
≥PWPERx	–	0	Low
–	\$00	1	High
–	\$00	0	Low

**Table 13-3. PWM Center-Aligned Boundary Conditions**

PWDTYx	PWPERx	PPOLx	Output
\$00	>\$00	1	Low
\$00	>\$00	0	High
≥PWPERx	–	1	High
≥PWPERx	–	0	Low
–	\$00	1	High
–	\$00	0	Low

## Section 14. Enhanced Capture Timer

### 14.1 Contents

14.2	Introduction . . . . .	197
14.3	Enhanced Capture Timer Modes of Operation . . . . .	203
14.4	Timer Registers . . . . .	207
14.5	Timer and Modulus Counter Operation in Different Modes . .	235

### 14.2 Introduction

The HC12 Enhanced Capture Timer module has the features of the HC12 Standard Timer module enhanced by additional features in order to enlarge the field of applications, in particular for automotive ABS applications.

The additional features permit the operation of this timer module in a mode similar to the Input Control Timer implemented on MC68HC11NB4.

These additional features are:

- 16-Bit Buffer Register for four Input Capture (IC) channels.
- Four 8-Bit Pulse Accumulators with 8-bit buffer registers associated with the four buffered IC channels. Configurable also as two 16-Bit Pulse Accumulators.
- 16-Bit Modulus Down-Counter with 4-bit Prescaler.
- Four user selectable Delay Counters for input noise immunity increase.
- Main Timer Prescaler extended to 7-bit.

## Enhanced Capture Timer

This design specification describes the standard timer as well as the additional features.

The basic timer consists of a 16-bit, software-programmable counter driven by a prescaler. This timer can be used for many purposes, including input waveform measurements while simultaneously generating an output waveform. Pulse widths can vary from microseconds to many seconds.

A full access for the counter registers or the input capture/output compare registers should take place in one clock cycle. Accessing high byte and low byte separately for all of these registers may not yield the same result as accessing them in one word.

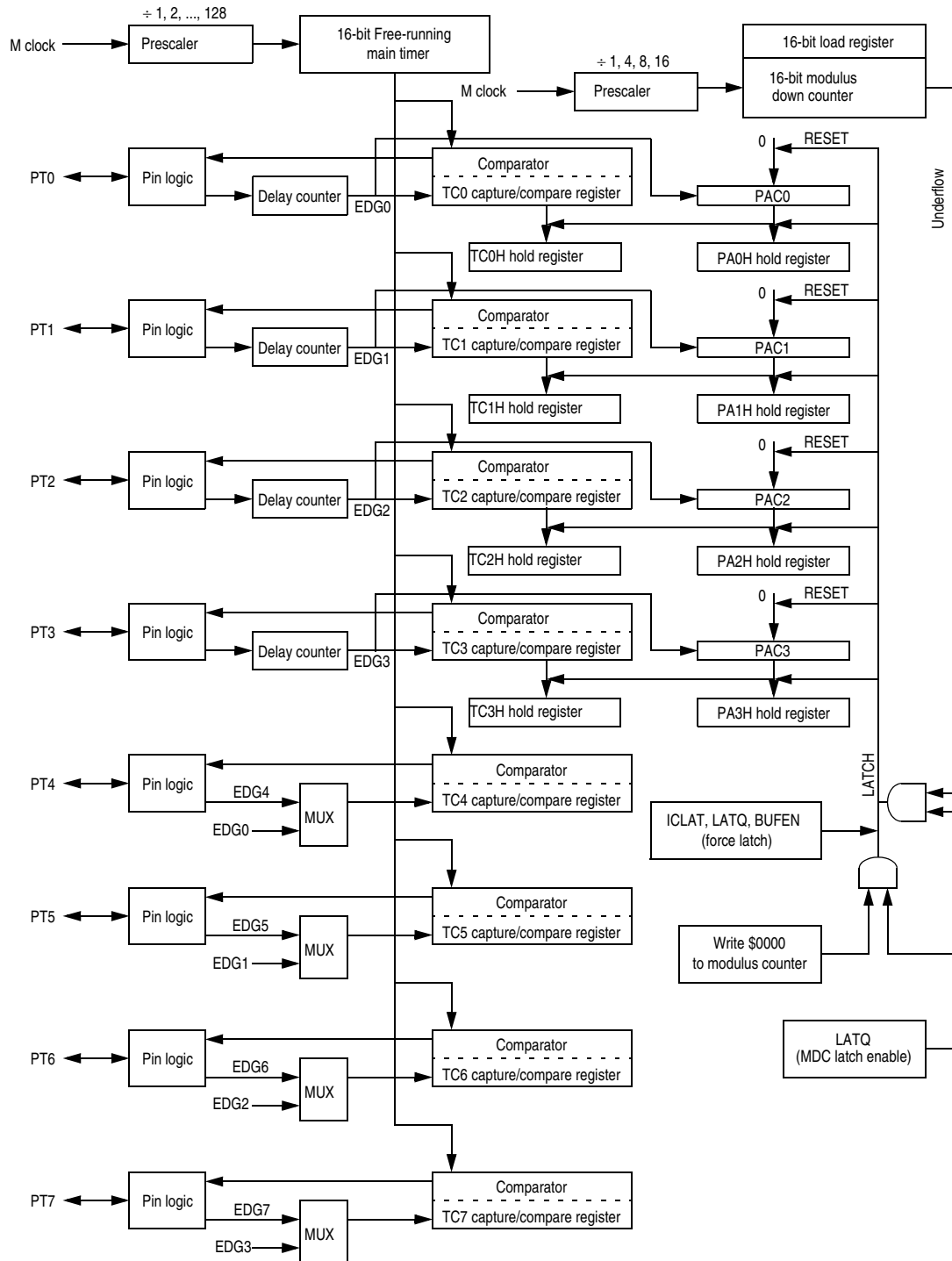
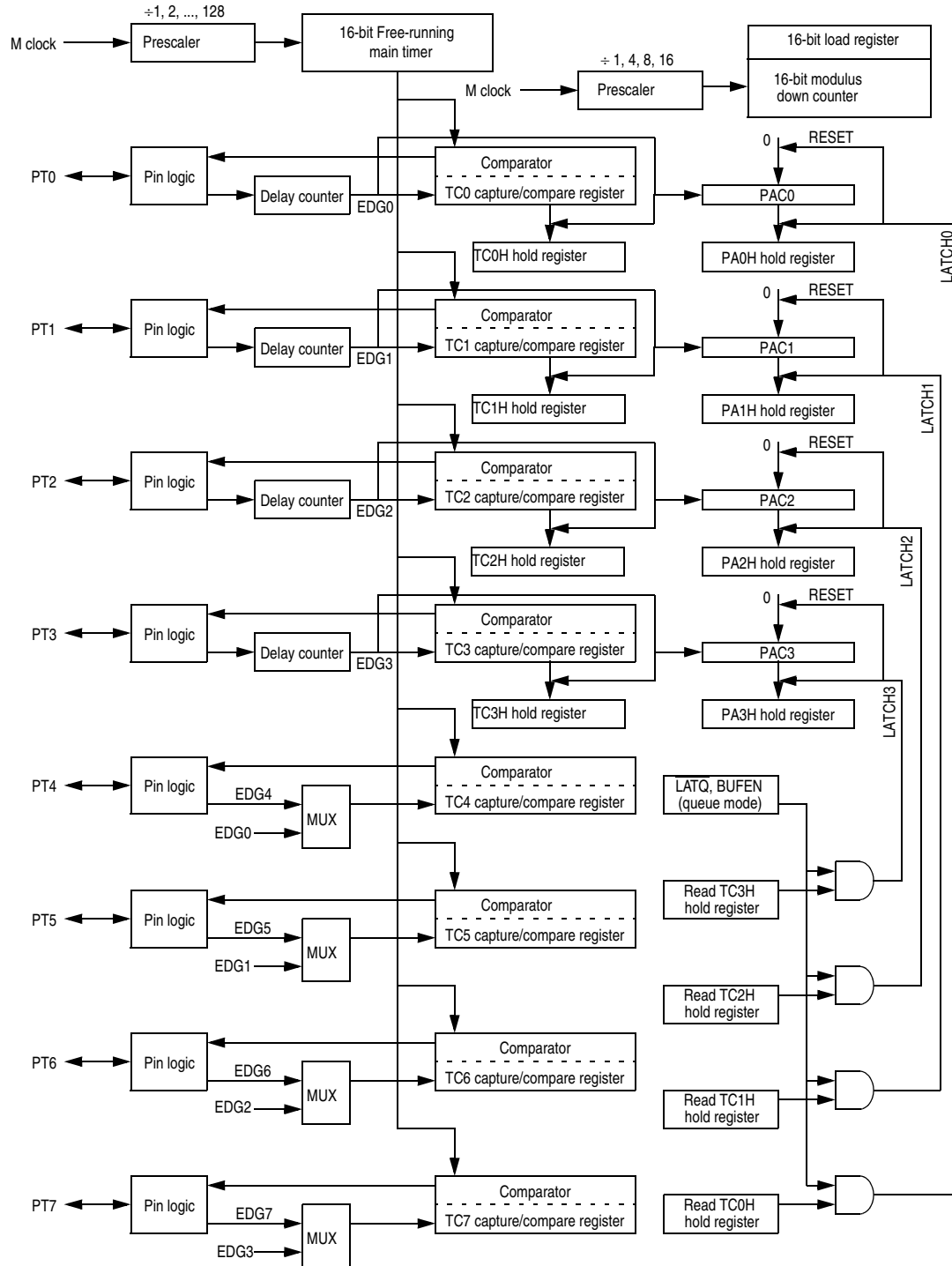


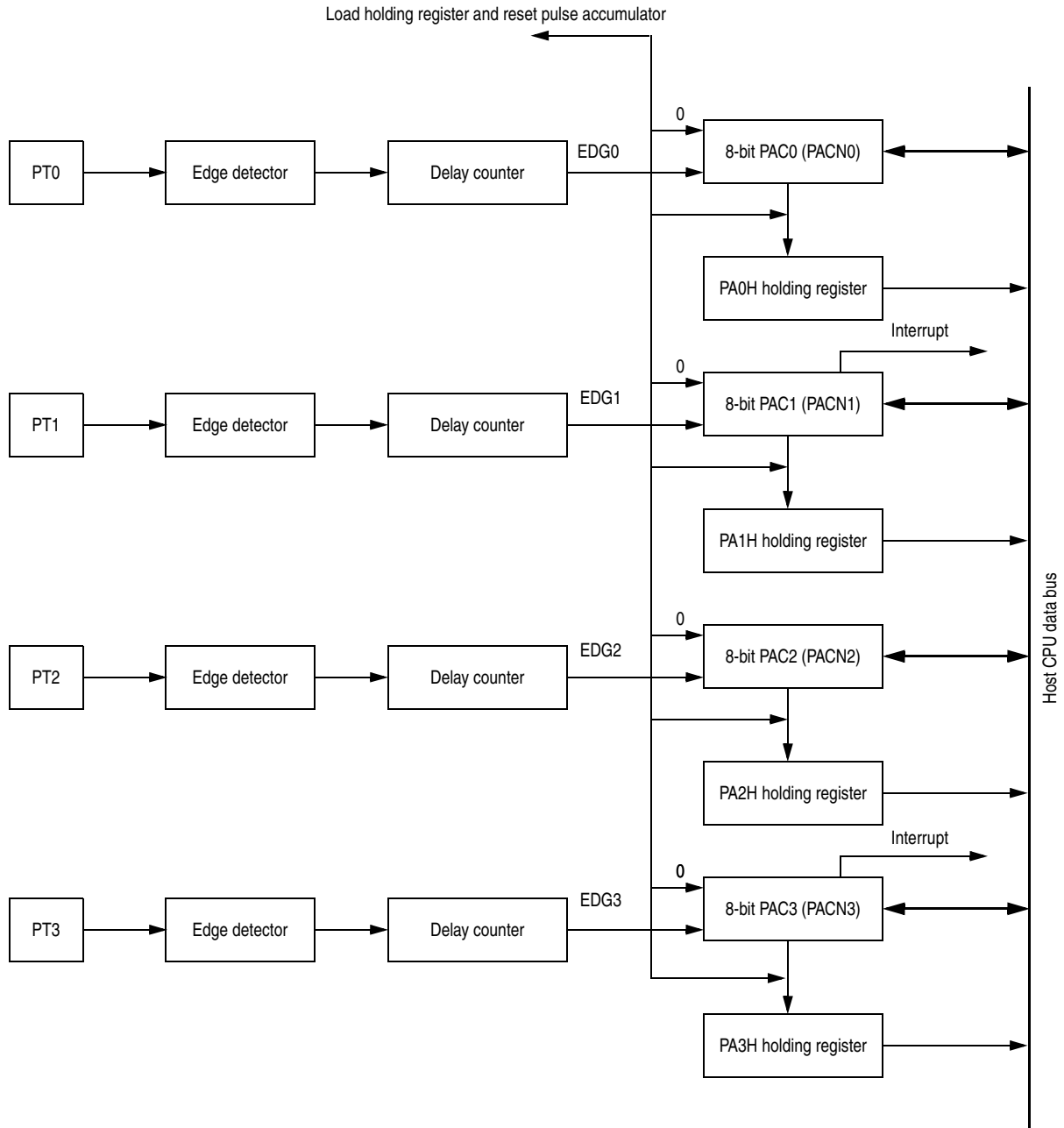
Figure 14-1. Timer Block Diagram in Latch Mode

# Enhanced Capture Timer



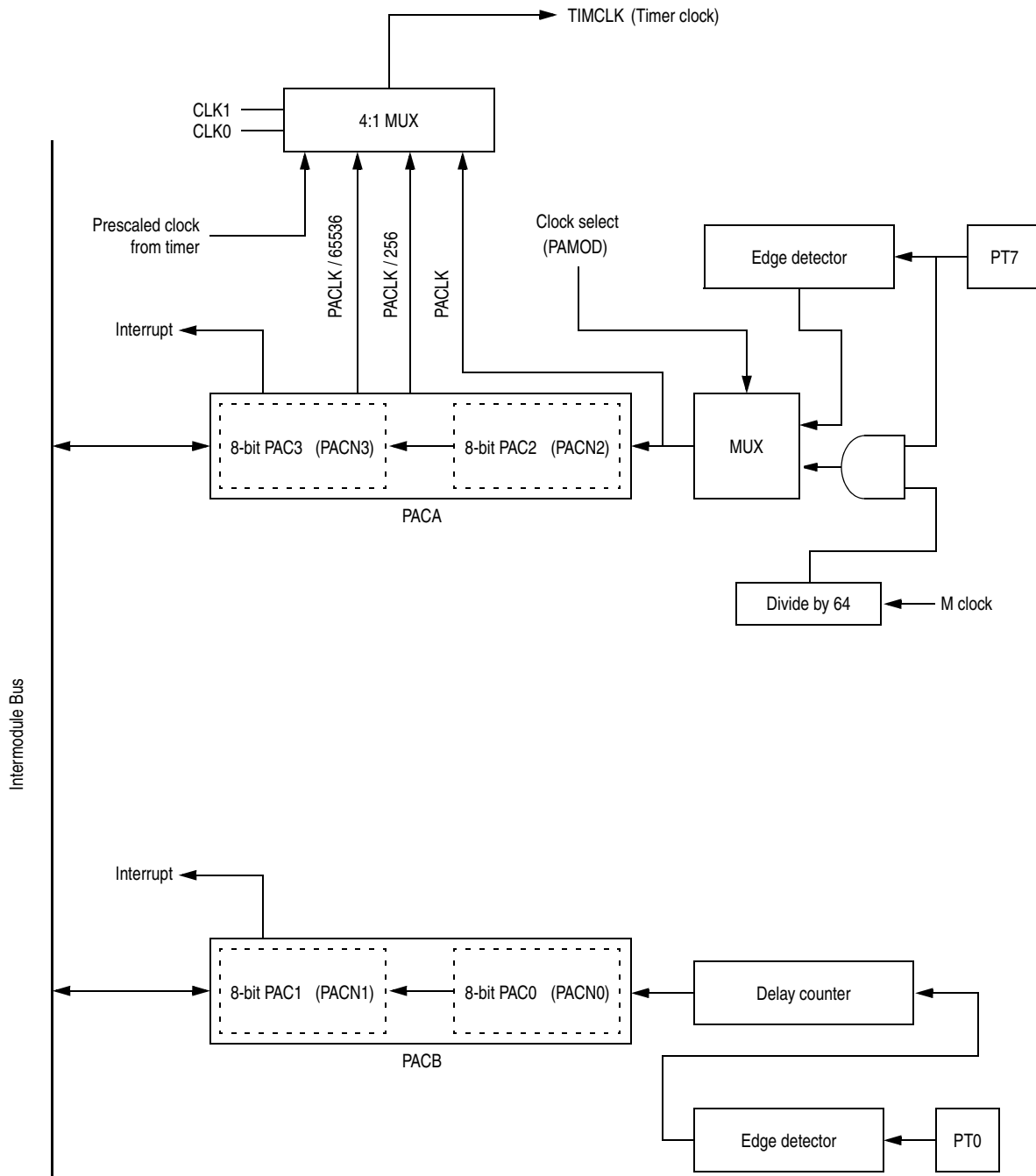
**Figure 14-2. Timer Block Diagram in Queue Mode**



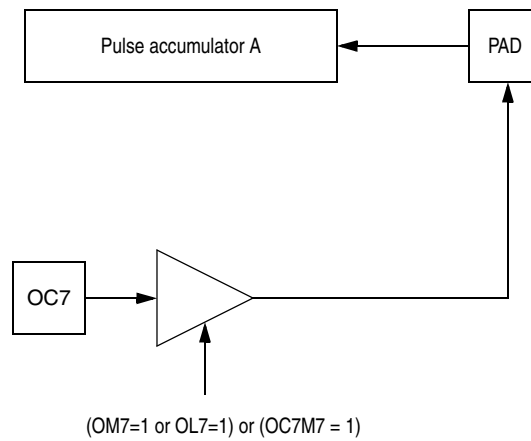


**Figure 14-3. 8-Bit Pulse Accumulators Block Diagram**

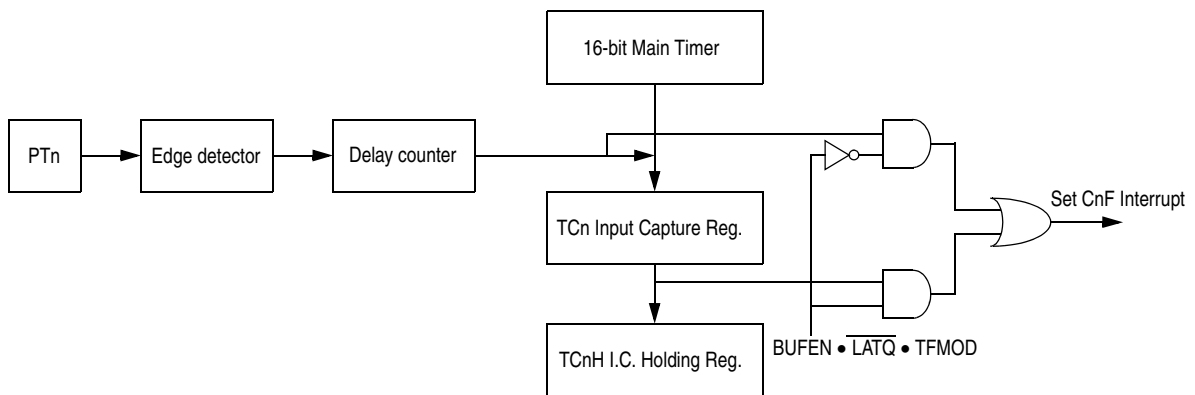
# Enhanced Capture Timer



**Figure 14-4. 16-Bit Pulse Accumulators Block Diagram**



**Figure 14-5. Block Diagram for Port7 with Output compare / Pulse Accumulator A**



**Figure 14-6. C3F-C0F Interrupt Flag Setting**

### 14.3 Enhanced Capture Timer Modes of Operation

The Enhanced Capture Timer has 8 Input Capture, Output Compare (IC/OC) channels same as on the HC12 standard timer (timer channels TC0 to TC7). When channels are selected as input capture by selecting

the IOSx bit in TIOS register, they are called Input Capture (IC) channels.

Four IC channels are the same as on the standard timer with one capture register which memorizes the timer value captured by an action on the associated input pin.

Four other IC channels, in addition to the capture register, have also one buffer called holding register. This permits to memorize two different timer values without generation of any interrupt.

Four 8-bit pulse accumulators are associated with the four buffered IC channels. Each pulse accumulator has a holding register to memorize their value by an action on its external input. Each pair of pulse accumulators can be used as a 16-bit pulse accumulator.

The 16-bit modulus down-counter can control the transfer of the IC registers contents and the pulse accumulators to the respective holding registers for a given period, every time the count reaches zero.

The modulus down-counter can also be used as a stand-alone time base with periodic interrupt capability.

### 14.3.1 IC Channels

The IC channels are composed of four standard IC registers and four buffered IC channels.

An **IC register** is **empty** when it has been read or latched into the holding register.

A **holding register** is **empty** when it has been read.

#### 14.3.1.1 Non-Buffered IC Channels

The main timer value is memorized in the IC register by a valid input pin transition. If the corresponding NOVWx bit of the ICOVW register is cleared, with a new occurrence of a capture, the contents of IC register are overwritten by the new value.

If the corresponding NOVWx bit of the ICOVW register is set, the capture register cannot be written unless it is empty.

This will prevent the captured value to be overwritten until it is read.

#### 14.3.1.2 Buffered IC Channels

There are two modes of operations for the buffered IC channels.

- **IC Latch Mode:**

When enabled (LATQ=1), the main timer value is memorized in the IC register by a valid input pin transition.

The value of the buffered IC register is latched to its holding register by the Modulus counter for a given period when the count reaches zero, by a write \$0000 to the modulus counter or by a write to ICLAT in the MCCTL register.

If the corresponding NOVWx bit of the ICOVW register is cleared, with a new occurrence of a capture, the contents of IC register are overwritten by the new value. In case of latching, the contents of its holding register are overwritten.

If the corresponding NOVWx bit of the ICOVW register is set, the capture register or its holding register cannot be written by an event unless they are empty (see [IC Channels](#)). This will prevent the captured value to be overwritten until it is read or latched in the holding register.

- **IC Queue Mode:**

When enabled (LATQ=0), the main timer value is memorized in the IC register by a valid input pin transition.

If the corresponding NOVWx bit of the ICOVW register is cleared, with a new occurrence of a capture, the value of the IC register will be transferred to its holding register and the IC register memorizes the new timer value.

If the corresponding NOVWx bit of the ICOVW register is set, the capture register or its holding register cannot be written by an event unless they are empty (see [IC Channels](#)).

In queue mode, reads of holding register will latch the corresponding pulse accumulator value to its holding register.

### 14.3.2 Pulse Accumulators

There are four 8-bit pulse accumulators with four 8-bit holding registers associated with the four IC buffered channels. A pulse accumulator counts the number of active edges at the input of its channel.

The user can prevent 8-bit pulse accumulators counting further than \$FF by PACMX control bit in ICSYS (\$AB). In this case a value of \$FF means that 255 counts or more have occurred.

Each pair of pulse accumulators can be used as a 16-bit pulse accumulator.

There are two modes of operation for the pulse accumulators.

#### 14.3.2.1 Pulse Accumulator latch mode

The value of the pulse accumulator is transferred to its holding register when the modulus down-counter reaches zero, a write \$0000 to the modulus counter or when the force latch control bit ICLAT is written.

At the same time the pulse accumulator is cleared.

#### 14.3.2.2 Pulse Accumulator queue mode

When queue mode is enabled, reads of an input capture holding register will transfer the contents of the associated pulse accumulator to its holding register.

At the same time the pulse accumulator is cleared.

### 14.3.3 Modulus Down-Counter

The modulus down-counter can be used as a time base to generate a periodic interrupt. It can also be used to latch the values of the IC registers and the pulse accumulators to their holding registers.

The action of latching can be programmed to be periodic or only once.

## 14.4 Timer Registers

Input/output pins default to general-purpose I/O lines until an internal function which uses that pin is specifically enabled. The timer overrides the state of the DDR to force the I/O state of each associated port line when an output compare using a port line is enabled. In these cases the data direction bits will have no affect on these lines.

When a pin is assigned to output an on-chip peripheral function, writing to this PORTT bit does not affect the pin but the data is stored in an internal latch such that if the pin becomes available for general-purpose output the driven level will be the last value written to the PORTT bit.

	Bit 7	6	5	4	3	2	1	Bit 0
	IOS7	IOS6	IOS5	IOS4	IOS3	IOS2	IOS1	IOS0
RESET:	0	0	0	0	0	0	0	0

**TIOS** — Timer Input Capture/Output Compare Select **\$0080**

Read or write anytime.

IOS[7:0] — Input Capture or Output Compare Channel Configuration  
 0 = The corresponding channel acts as an input capture  
 1 = The corresponding channel acts as an output compare.

## Enhanced Capture Timer

Bit 7	6	5	4	3	2	1	Bit 0
FOC7	FOC6	FOC5	FOC4	FOC3	FOC2	FOC1	FOC0

RESET: 0 0 0 0 0 0 0 0

**CFORC** — Timer Compare Force Register

**\$0081**

Read anytime but will always return \$00 (1 state is transient). Write anytime.

**FOC[7:0]** — Force Output Compare Action for Channel 7-0

A write to this register with the corresponding data bit(s) set causes the action which is programmed for output compare “n” to occur immediately. The action taken is the same as if a successful comparison had just taken place with the TCn register except the interrupt flag does not get set.

Bit 7	6	5	4	3	2	1	Bit 0
OC7M7	OC7M6	OC7M5	OC7M4	OC7M3	OC7M2	OC7M1	OC7M0

RESET: 0 0 0 0 0 0 0 0

**OC7M** — Output Compare 7 Mask Register

**\$0082**

Read or write anytime.

The bits of OC7M correspond bit-for-bit with the bits of timer port (PORTT). Setting the OC7Mn will set the corresponding port to be an output port regardless of the state of the DDRTn bit when the corresponding IOSn bit is set to be an output compare. This does not change the state of the DDRT bits. At successful OC7, for each bit that is set in OC7M, the corresponding data bit OC7D is stored to the corresponding bit of the timer port.

**NOTE:** *OC7M has priority over output action on the timer port enabled by OMn and OLn bits in TCTL1 and TCTL2. If an OC7M bit is set, it prevents the action of corresponding OM and OL bits on the selected timer port.*



Bit 7	6	5	4	3	2	1	Bit 0
OC7D7	OC7D6	OC7D5	OC7D4	OC7D3	OC7D2	OC7D1	OC7D0

RESET: 0 0 0 0 0 0 0 0

**OC7D** — Output Compare 7 Data Register

**\$0083**

Read or write anytime.

The bits of OC7D correspond bit-for-bit with the bits of timer port (PORTT). When a successful OC7 compare occurs, for each bit that is set in OC7M, the corresponding data bit in OC7D is stored to the corresponding bit of the timer port.

When the OC7Mn bit is set, a successful OC7 action will override a successful OC[6:0] compare action during the same cycle; therefore, the OCn action taken will depend on the corresponding OC7D bit.

Bit 7	6	5	4	3	2	1	Bit 0
Bit 15	14	13	12	11	10	9	Bit 8
Bit 7	6	5	4	3	2	1	Bit 0

RESET: 0 0 0 0 0 0 0 0

**TCNT** — Timer Count Register

**\$0084–\$0085**

The 16-bit main timer is an up counter.

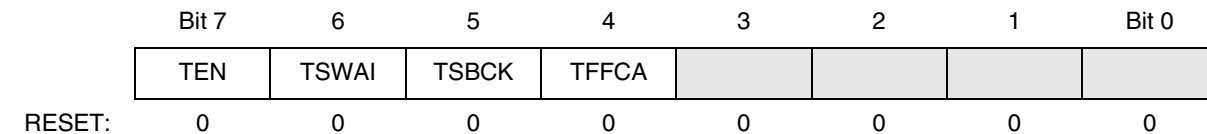
A full access for the counter register should take place in one clock cycle. A separate read/write for high byte and low byte will give a different result than accessing them as a word.

Read anytime.

Write has no meaning or effect in the normal mode; only writable in special modes (SMODN = 0).

## Enhanced Capture Timer

The period of the first count after a write to the TCNT registers may be a different size because the write is not synchronized with the prescaler clock.



**TSCR** — Timer System Control Register

**\$0086**

Read or write anytime.

**TEN** — Timer Enable

0 = Disables the main timer, including the counter. Can be used for reducing power consumption.

1 = Allows the timer to function normally.

If for any reason the timer is not active, there is no  $\div 64$  clock for the pulse accumulator since the  $E\div 64$  is generated by the timer prescaler.

**TSWAI** — Timer Module Stops While in Wait

0 = Allows the timer module to continue running during wait.

1 = Disables the timer module when the MCU is in the wait mode. Timer interrupts cannot be used to get the MCU out of wait.

TSWAI also affects pulse accumulators and modulus down counters.

**TSBCK** — Timer and Modulus Counter Stop While in Background Mode

0 = Allows the timer and modulus counter to continue running while in background mode.

1 = Disables the timer and modulus counter whenever the MCU is in background mode. This is useful for emulation.

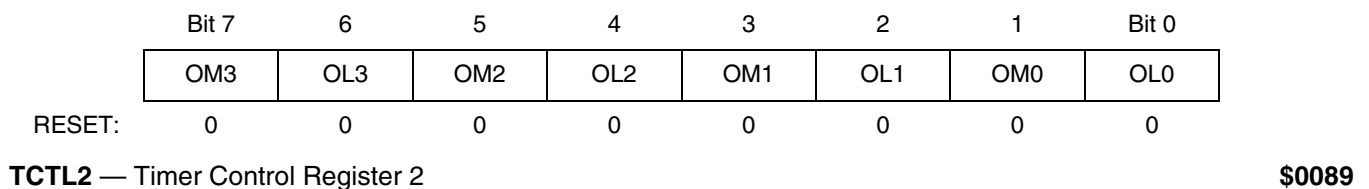
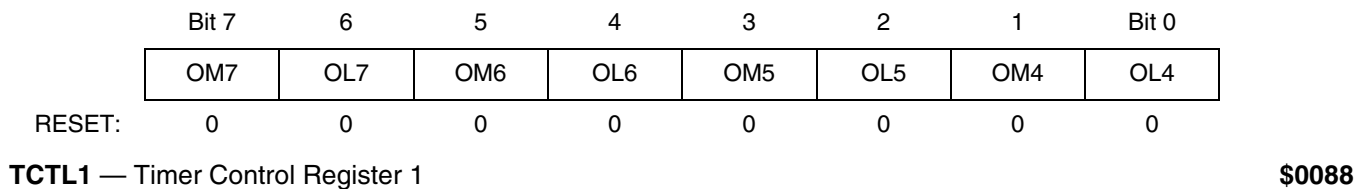
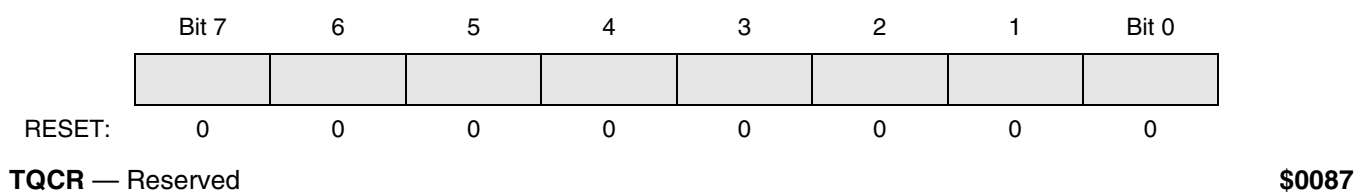
TBSCK does not stop the pulse accumulator.

**TFFCA** — Timer Fast Flag Clear All

0 = Allows the timer flag clearing to function normally.

1 = For TFLG1 (\$8E), a read from an input capture or a write to the output compare channel (\$90–\$9F) causes the corresponding channel flag, CnF, to be cleared. For TFLG2 (\$8F), any access to the TCNT register (\$84, \$85) clears the TOF flag. Any access to the PACN3 and PACN2 registers (\$A2, \$A3) clears

the PAOVF and PAIF flags in the PAFLG register (\$A1). Any access to the PACN1 and PACN0 registers (\$A4, \$A5) clears the PBOVF flag in the PBFLG register (\$B1). Any access to the MCCNT register (\$B6, \$B7) clears the MCZF flag in the MCFLG register (\$A7). This has the advantage of eliminating software overhead in a separate clear sequence. Extra care is required to avoid accidental flag clearing due to unintended accesses.



Read or write anytime.

OM<sub>n</sub> — Output Mode

OL<sub>n</sub> — Output Level

These eight pairs of control bits are encoded to specify the output action to be taken as a result of a successful OC<sub>n</sub> compare. When either OM<sub>n</sub> or OL<sub>n</sub> is one, the pin associated with OC<sub>n</sub> becomes an output tied to OC<sub>n</sub> regardless of the state of the associated DDRT bit.

**NOTE:** To enable output action by OM<sub>n</sub> and OL<sub>n</sub> bits on the timer port, the corresponding bit in OC7M should be cleared.

**Table 14-1. Compare Result Output Action**

OMn	OLn	Action
0	0	Timer disconnected from output pin logic
0	1	Toggle OCn output line
1	0	Clear OCn output line to zero
1	1	Set OCn output line to one

To operate the 16-bit pulse accumulators A and B (PACA and PACB) independently of input capture or output compare 7 and 0 respectively the user must set the corresponding bits IOSn = 1, OMn = 0 and OLn = 0. OC7M7 or OC7M0 in the OC7M register must also be cleared.

Bit 7	6	5	4	3	2	1	Bit 0
EDG7B	EDG7A	EDG6B	EDG6A	EDG5B	EDG5A	EDG4B	EDG4A

RESET: 0 0 0 0 0 0 0 0

**TCTL3** — Timer Control Register 3

**\$008A**

Bit 7	6	5	4	3	2	1	Bit 0
EDG3B	EDG3A	EDG2B	EDG2A	EDG1B	EDG1A	EDG0B	EDG0A

RESET: 0 0 0 0 0 0 0 0

**TCTL4** — Timer Control Register 4

**\$008B**

Read or write anytime.

**EDGnB, EDGnA** — Input Capture Edge Control

These eight pairs of control bits configure the input capture edge detector circuits.

**Table 14-2. Edge Detector Circuit Configuration**

EDGnB	EDGnA	Configuration
0	0	Capture disabled
0	1	Capture on rising edges only
1	0	Capture on falling edges only
1	1	Capture on any edge (rising or falling)

Bit 7	6	5	4	3	2	1	Bit 0
C7I	C6I	C5I	C4I	C3I	C2I	C1I	C0I

RESET: 0 0 0 0 0 0 0 0

**TMSK1** — Timer Interrupt Mask 1

**\$008C**

Read or write anytime.

The bits in TMSK1 correspond bit-for-bit with the bits in the TFLG1 status register. If cleared, the corresponding flag is disabled from causing a hardware interrupt. If set, the corresponding flag is enabled to cause a hardware interrupt.

Read or write anytime.

C7I–C0I — Input Capture/Output Compare “x” Interrupt Enable.

Bit 7	6	5	4	3	2	1	Bit 0
TOI	0	PUPT	RDPT	TCRE	PR2	PR1	PR0

RESET: 0 0 0 0 0 0 0 0

**TMSK2** — Timer Interrupt Mask 2

**\$008D**

Read or write anytime.

TOI — Timer Overflow Interrupt Enable

0 = Interrupt inhibited

1 = Hardware interrupt requested when TOF flag set

PUPT — Timer Port Pull-Up Resistor Enable

This enable bit controls pull-up resistors on the timer port pins when the pins are configured as inputs.

0 = Disable pull-up resistor function

1 = Enable pull-up resistor function

## RDPT — Timer Port Drive Reduction

This bit reduces the effective output driver size which can reduce power supply current and generated noise depending upon pin loading.

0 = Normal output drive capability

1 = Enable output drive reduction function

## TCRE — Timer Counter Reset Enable

This bit allows the timer counter to be reset by a successful output compare 7 event. This mode of operation is similar to an up-counting modulus counter.

0 = Counter reset inhibited and counter free runs

1 = Counter reset by a successful output compare 7

If TC7 = \$0000 and TCRE = 1, TCNT will stay at \$0000 continuously. If TC7 = \$FFFF and TCRE = 1, TOF will never be set when TCNT is reset from \$FFFF to \$0000.

## PR2, PR1, PR0 — Timer Prescaler Select

These three bits specify the number of ÷2 stages that are to be inserted between the module clock and the main timer counter.

**Table 14-3. Prescaler Selection**

PR2	PR1	PR0	Prescale Factor
0	0	0	1
0	0	1	2
0	1	0	4
0	1	1	8
1	0	0	16
1	0	1	32
1	1	0	64
1	1	1	128

The newly selected prescale factor will not take effect until the next synchronized edge where all prescale counter stages equal zero.

Bit 7	6	5	4	3	2	1	Bit 0
C7F	C6F	C5F	C4F	C3F	C2F	C1F	C0F

RESET: 0 0 0 0 0 0 0 0

**TFLG1** — Main Timer Interrupt Flag 1

**\$008E**

TFLG1 indicates when interrupt conditions have occurred. To clear a bit in the flag register, write a one to the bit.

Use of the TFMOD bit in the ICSYS register (\$AB) in conjunction with the use of the ICOVW register (\$AA) allows a timer interrupt to be generated after capturing two values in the capture and holding registers instead of generating an interrupt for every capture.

Read anytime. Write used in the clearing mechanism (set bits cause corresponding bits to be cleared). Writing a zero will not affect current status of the bit.

When TFFCA bit in TSCR register is set, a read from an input capture or a write into an output compare channel (\$90–\$9F) will cause the corresponding channel flag CnF to be cleared.

C7F–C0F — Input Capture/Output Compare Channel “n” Flag.

Bit 7	6	5	4	3	2	1	Bit 0
TOF	0	0	0	0	0	0	0

RESET: 0 0 0 0 0 0 0 0

**TFLG2** — Main Timer Interrupt Flag 2

**\$008F**

TFLG2 indicates when interrupt conditions have occurred. To clear a bit in the flag register, set the bit to one.

Read anytime. Write used in clearing mechanism (set bits cause corresponding bits to be cleared).

Any access to TCNT will clear TFLG2 register if the TFFCA bit in TSCR register is set.

## Enhanced Capture Timer

### TOF — Timer Overflow Flag

Set when 16-bit free-running timer overflows from \$FFFF to \$0000. This bit is cleared automatically by a write to the TFLG2 register with bit 7 set. (See also TCRE control bit explanation.)

Bit 7	6	5	4	3	2	1	Bit 0
Bit 15	14	13	12	11	10	9	Bit 8
Bit 7	6	5	4	3	2	1	Bit 0

**TC0** — Timer Input Capture/Output Compare Register 0

**\$0090–\$0091**

Bit 7	6	5	4	3	2	1	Bit 0
Bit 15	14	13	12	11	10	9	Bit 8
Bit 7	6	5	4	3	2	1	Bit 0

**TC1** — Timer Input Capture/Output Compare Register 1

**\$0092–\$0093**

Bit 7	6	5	4	3	2	1	Bit 0
Bit 15	14	13	12	11	10	9	Bit 8
Bit 7	6	5	4	3	2	1	Bit 0

**TC2** — Timer Input Capture/Output Compare Register 2

**\$0094–\$0095**

Bit 7	6	5	4	3	2	1	Bit 0
Bit 15	14	13	12	11	10	9	Bit 8
Bit 7	6	5	4	3	2	1	Bit 0

**TC3** — Timer Input Capture/Output Compare Register 3

**\$0096–\$0097**

Bit 7	6	5	4	3	2	1	Bit 0
Bit 15	14	13	12	11	10	9	Bit 8
Bit 7	6	5	4	3	2	1	Bit 0

**TC4** — Timer Input Capture/Output Compare Register 4

**\$0098–\$0099**

Bit 7	6	5	4	3	2	1	Bit 0
Bit 15	14	13	12	11	10	9	Bit 8
Bit 7	6	5	4	3	2	1	Bit 0

**TC5** — Timer Input Capture/Output Compare Register 5

**\$009A–\$009B**



Bit 7	6	5	4	3	2	1	Bit 0
Bit 15	14	13	12	11	10	9	Bit 8
Bit 7	6	5	4	3	2	1	Bit 0

**TC6** — Timer Input Capture/Output Compare Register 6 **\$009C–\$009D**

Bit 7	6	5	4	3	2	1	Bit 0
Bit 15	14	13	12	11	10	9	Bit 8
Bit 7	6	5	4	3	2	1	Bit 0

**TC7** — Timer Input Capture/Output Compare Register 7 **\$009E–\$009F**

Depending on the TIOS bit for the corresponding channel, these registers are used to latch the value of the free-running counter when a defined transition is sensed by the corresponding input capture edge detector or to trigger an output action for output compare.

Read anytime. Write anytime for output compare function. Writes to these registers have no meaning or effect during input capture. All timer input capture/output compare registers are reset to \$0000.

BIT 7	6	5	4	3	2	1	BIT 0
0	PAEN	PAMOD	PEDGE	CLK1	CLK0	PAOVI	PAI

RESET:      0            0            0            0            0            0            0            0

**PACTL** — 16-Bit Pulse Accumulator A Control Register **\$00A0**

16-Bit Pulse Accumulator A (PACA) is formed by cascading the 8-bit pulse accumulators PAC3 and PAC2.

When PAEN is set, the PACA is enabled. The PACA shares the input pin with IC7.

Read: any time

Write: any time

## PAEN — Pulse Accumulator A System Enable

0 = 16-Bit Pulse Accumulator A system disabled. 8-bit PAC3 and PAC2 can be enabled when their related enable bits in ICPACR (\$A8) are set.

Pulse Accumulator Input Edge Flag (PAIF) function is disabled.

1 = Pulse Accumulator A system enabled. The two 8-bit pulse accumulators PAC3 and PAC2 are cascaded to form the PACA 16-bit pulse accumulator. When PACA is enabled, the PACN3 and PACN2 registers contents are respectively the high and low byte of the PACA.

PA3EN and PA2EN control bits in ICPACR (\$A8) have no effect.

Pulse Accumulator Input Edge Flag (PAIF) function is enabled.

PAEN is independent from TEN. With timer disabled, the pulse accumulator can still function unless pulse accumulator is disabled.

## PAMOD — Pulse Accumulator Mode

0 = event counter mode

1 = gated time accumulation mode

## PEDGE — Pulse Accumulator Edge Control

For PAMOD bit = 0 (event counter mode).

0 = falling edges on PT7 pin cause the count to be incremented

1 = rising edges on PT7 pin cause the count to be incremented

For PAMOD bit = 1 (gated time accumulation mode).

0 = PT7 input pin high enables M divided by 64 clock to Pulse Accumulator and the trailing falling edge on PT7 sets the PAIF flag.

1 = PT7 input pin low enables M divided by 64 clock to Pulse Accumulator and the trailing rising edge on PT7 sets the PAIF flag.

PAMOD	PEDGE	Pin Action
0	0	Falling edge
0	1	Rising edge
1	0	Div. by 64 clock enabled with pin high level
1	1	Div. by 64 clock enabled with pin low level

If the timer is not active (TEN = 0 in TSCR), there is no divide-by-64 since the E-64 clock is generated by the timer prescaler.

**CLK1, CLK0 — Clock Select Bits**

CLK1	CLK0	Clock Source
0	0	Use timer prescaler clock as timer counter clock
0	1	Use PCLK as input to timer counter clock
1	0	Use PCLK/256 as timer counter clock frequency
1	1	Use PCLK/65536 as timer counter clock frequency

If the pulse accumulator is disabled (PAEN = 0), the prescaler clock from the timer is always used as an input clock to the timer counter. The change from one selected clock to the other happens immediately after these bits are written.

**PAOVI — Pulse Accumulator A Overflow Interrupt enable**

- 0 = interrupt inhibited
- 1 = interrupt requested if PAOVF is set

**PAI — Pulse Accumulator Input Interrupt enable**

- 0 = interrupt inhibited
- 1 = interrupt requested if PAIF is set

BIT 7	6	5	4	3	2	1	BIT 0
0	0	0	0	0	0	PAOVF	PAIF
RESET:	0	0	0	0	0	0	0

**PAFLG — Pulse Accumulator A Flag Register**

**\$00A1**

Read or write anytime. When the TFFCA bit in the TSCR register is set, any access to the PACNT register will clear all the flags in the PAFLG register.

**PAOVF — Pulse Accumulator A Overflow Flag**

Set when the 16-bit pulse accumulator A overflows from \$FFFF to \$0000, or when 8-bit pulse accumulator 3 (PAC3) overflows from \$FF to \$00.

## Enhanced Capture Timer

This bit is cleared automatically by a write to the PAFLG register with bit 1 set.

### PAIF — Pulse Accumulator Input edge Flag

Set when the selected edge is detected at the PT7 input pin. In event mode the event edge triggers PAIF and in gated time accumulation mode the trailing edge of the gate signal at the PT7 input pin triggers PAIF.

This bit is cleared by a write to the PAFLG register with bit 0 set. Any access to the PACN3, PACN2 registers will clear all the flags in this register when TFFCA bit in register TSCR(\$86) is set.

	BIT 7	6	5	4	3	2	1	BIT 0	
\$00A2	Bit 7	6	5	4	3	2	1	Bit 0	PACN3 (hi)
\$00A3	Bit 7	6	5	4	3	2	1	Bit 0	PACN2 (lo)
RESET:	0	0	0	0	0	0	0	0	

**PACN3, PACN2** — Pulse Accumulators Count Registers

**\$00A2, \$00A3**

Read: any time

Write: any time

The two 8-bit pulse accumulators PAC3 and PAC2 are cascaded to form the PACA 16-bit pulse accumulator. When PACA is enabled (PAEN=1 in PACTL, \$A0) the PACN3 and PACN2 registers contents are respectively the high and low byte of the PACA.

When PACN3 overflows from \$FF to \$00, the Interrupt flag PAOVF in PAFLG (\$A1) is set.

Full count register access should take place in one clock cycle. A separate read/write for high byte and low byte will give a different result than accessing them as a word.

	BIT 7	6	5	4	3	2	1	BIT 0	
\$00A4	Bit 7	6	5	4	3	2	1	Bit 0	PACN1 (hi)
\$00A5	Bit 7	6	5	4	3	2	1	Bit 0	PACN0 (lo)
RESET:	0	0	0	0	0	0	0	0	

**PACN1, PACN0** — Pulse Accumulators Count Registers

**\$00A4, \$00A5**

Read: any time

Write: any time

The two 8-bit pulse accumulators PAC1 and PAC0 are cascaded to form the PACB 16-bit pulse accumulator. When PACB is enabled, (PBEN=1 in PBCTL, \$B0) the PACN1 and PACN0 registers contents are respectively the high and low byte of the PACB.

When PACN1 overflows from \$FF to \$00, the Interrupt flag PBOVF in PBFLG (\$B1) is set.

Full count register access should take place in one clock cycle. A separate read/write for high byte and low byte will give a different result than accessing them as a word.

	BIT 7	6	5	4	3	2	1	BIT 0
	MCZI	MODMC	RDMCL	ICLAT	FLMC	MCEN	MCPRI	MCPRI
RESET:	0	0	0	0	0	0	0	0

**MCCTL** — 16-Bit Modulus Down-Counter Control Register

**\$00A6**

Read: any time

Write: any time

**MCZI** — Modulus Counter Underflow Interrupt Enable

0 = Modulus counter interrupt is disabled.

1 = Modulus counter interrupt is enabled.

### MODMC — Modulus Mode Enable

- 0 = The counter counts once from the value written to it and will stop at \$0000.
- 1 = Modulus mode is enabled. When the counter reaches \$0000, the counter is loaded with the latest value written to the modulus count register.

**NOTE:** *For proper operation, the MCEN bit should be cleared before modifying the MODMC bit in order to reset the modulus counter to \$FF.*

### RDMCL — Read Modulus Down-Counter Load

- 0 = Reads of the modulus count register will return the present value of the count register.
- 1 = Reads of the modulus count register will return the contents of the load register.

### ICLAT — Input Capture Force Latch Action

When input capture latch mode is enabled (LATQ and BUFEN bit in ICSYS (\$AB) are set), a write one to this bit immediately forces the contents of the input capture registers TC0 to TC3 and their corresponding 8-bit pulse accumulators to be latched into the associated holding registers. The pulse accumulators will be automatically cleared when the latch action occurs.

Writing zero to this bit has no effect. Read of this bit will return always zero.

### FLMC — Force Load Register into the Modulus Counter Count Register

This bit is active only when the modulus down-counter is enabled (MCEN=1).

A write one into this bit loads the load register into the modulus counter count register. This also resets the modulus counter prescaler.

Write zero to this bit has no effect.

When MODMC=0, counter starts counting and stops at \$0000.

Read of this bit will return always zero.

**MCEN — Modulus Down-Counter Enable**

0 = Modulus counter disabled.

1 = Modulus counter is enabled.

When MCEN=0, the counter is preset to \$FFFF. This will prevent an early interrupt flag when the modulus down-counter is enabled.

**MCPR1, MCPR0 — Modulus Counter Prescaler select**

These two bits specify the division rate of the modulus counter prescaler.

The newly selected prescaler division rate will not be effective until a load of the load register into the modulus counter count register occurs.

MCPR1	MCPR0	Prescaler division rate
0	0	1
0	1	4
1	0	8
1	1	16

BIT 7	6	5	4	3	2	1	BIT 0
MCZF	0	0	0	POLF3	POLF2	POLF1	POLF0
RESET:	0	0	0	0	0	0	0

**MCFLG — 16-Bit Modulus Down-Counter FLAG Register**

**\$00A7**

Read: any time

Write: Only for clearing bit 7

**MCZF — Modulus Counter Underflow Interrupt Flag**

The flag is set when the modulus down-counter reaches \$0000.

Writing a 1 to this bit clears the flag (if TFFCA=0). Writing zero has no effect.

Any access to the MCCNT register will clear the MCZF flag in this register when TFFCA bit in register TSCR(\$86) is set.

## Enhanced Capture Timer

### POLF3 – POLF0 — First Input Capture Polarity Status

These are read only bits. Write to these bits has no effect.

Each status bit gives the polarity of the first edge which has caused an input capture to occur after capture latch has been read.

Each POLFx corresponds to a timer PORTx input.

0 = The first input capture has been caused by a falling edge.

1 = The first input capture has been caused by a rising edge.

	BIT 7	6	5	4	3	2	1	BIT 0
	0	0	0	0	PA3EN	PA2EN	PA1EN	PA0EN
RESET:	0	0	0	0	0	0	0	0

**ICPACR** — Input Control Pulse Accumulators Control Register

**\$00A8**

The 8-bit pulse accumulators PAC3 and PAC2 can be enabled only if PAEN in PATCL (\$A0) is cleared. If PAEN is set, PA3EN and PA2EN have no effect.

The 8-bit pulse accumulators PAC1 and PAC0 can be enabled only if PBEN in PBTCL (\$B0) is cleared. If PBEN is set, PA1EN and PA0EN have no effect.

Read: any time

Write: any time

**PAXEN** — 8-Bit Pulse Accumulator 'x' Enable

0 = 8-Bit Pulse Accumulator is disabled.

1 = 8-Bit Pulse Accumulator is enabled.



BIT 7	6	5	4	3	2	1	BIT 0
0	0	0	0	0	0	DLY1	DLY0

RESET: 0 0 0 0 0 0 0 0

**DLYCT** — Delay Counter Control Register

**\$00A9**

Read: any time

Write: any time

If enabled, after detection of a valid edge on input capture pin, the delay counter counts the pre-selected number of M clock (module clock) cycles, then it will generate a pulse on its output. The pulse is generated only if the level of input signal, after the preset delay, is the opposite of the level before the transition. This will avoid reaction to narrow input pulses.

After counting, the counter will be cleared automatically.

Delay between two active edges of the input signal period should be longer than the selected counter delay.

DLYx — Delay Counter Select

DLY1	DLY0	Delay
0	0	Disabled (bypassed)
0	1	256 M clock cycles
1	0	512 M clock cycles
1	1	1024 M clock cycles

BIT 7	6	5	4	3	2	1	BIT 0
NOVW7	NOVW6	NOVW5	NOVW4	NOVW3	NOVW2	NOVW1	NOVW0

RESET: 0 0 0 0 0 0 0 0

**ICOVW** — Input Control Overwrite Register

**\$00AA**

Read: any time

Write: any time

## Enhanced Capture Timer

An IC register is empty when it has been read or latched into the holding register.

A holding register is empty when it has been read.

**NOVW<sub>x</sub>** — No Input Capture Overwrite

0 = The contents of the related capture register or holding register can be overwritten when a new input capture or latch occurs.

1 = The related capture register or holding register cannot be written by an event unless they are empty (see [IC Channels](#)). This will prevent the captured value to be overwritten until it is read or latched in the holding register.

	BIT 7	6	5	4	3	2	1	BIT 0
	SH37	SH26	SH15	SH04	TFMOD	PACMX	BUFEN	LATQ
RESET:	0	0	0	0	0	0	0	0

**ICSYS** — Input Control System Control Register

**\$00AB**

Read: any time

Write: May be written once (SMODN=1). Writes are always permitted when SMODN=0.

**SH<sub>xy</sub>** — Share Input action of Input Capture Channels x and y

0 = Normal operation

1 = The channel input 'x' causes the same action on the channel 'y'. The port pin 'x' and the corresponding edge detector is used to be active on the channel 'y'.

**TFMOD** — Timer Flag-setting Mode

Use of the TFMOD bit in the ICSYS register (\$AB) in conjunction with the use of the ICOVW register (\$AA) allows a timer interrupt to be generated after capturing two values in the capture and holding registers instead of generating an interrupt for every capture.

By setting TFMOD in queue mode, when NOVW bit is set and the corresponding capture and holding registers are emptied, an input capture event will first update the related input capture register with

the main timer contents. At the next event the TCn data is transferred to the TCnH register, The TCn is updated and the CnF interrupt flag is set. See [Figure 14-6](#).

In all other input capture cases the interrupt flag is set by a valid external event on PTn.

0 = The timer flags C3F–C0F in TFLG1 (\$8E) are set when a valid input capture transition on the corresponding port pin occurs.

1 = If in queue mode (BUFEN=1 and LATQ=0), the timer flags C3F–C0F in TFLG1 (\$8E) are set only when a latch on the corresponding holding register occurs.

If the queue mode is not engaged, the timer flags C3F–C0F are set the same way as for TFMOD=0.

#### PACMX — 8-Bit Pulse Accumulators Maximum Count

0 = Normal operation. When the 8-bit pulse accumulator has reached the value \$FF, with the next active edge, it will be incremented to \$00.

1 = When the 8-bit pulse accumulator has reached the value \$FF, it will not be incremented further. The value \$FF indicates a count of 255 or more.

#### BUFEN — IC Buffer Enable

0 = Input Capture and pulse accumulator holding registers are disabled.

1 = Input Capture and pulse accumulator holding registers are enabled. The latching mode is defined by LATQ control bit. Write one into ICLAT bit in MCCTL (\$A6), when LATQ is set will produce latching of input capture and pulse accumulators registers into their holding registers.

#### LATQ — Input Control Latch or Queue Mode Enable

The BUFEN control bit should be set in order to enable the IC and pulse accumulators holding registers. Otherwise LATQ latching modes are disabled.

Write one into ICLAT bit in MCCTL (\$A6), when LATQ and BUFEN are set will produce latching of input capture and pulse accumulators registers into their holding registers.

## Enhanced Capture Timer

0 = Queue Mode of Input Capture is enabled.

The main timer value is memorized in the IC register by a valid input pin transition.

With a new occurrence of a capture, the value of the IC register will be transferred to its holding register and the IC register memorizes the new timer value.

1 = Latch Mode is enabled. Latching function occurs when modulus down-counter reaches zero or a zero is written into the count register MCCNT (see [Buffered IC Channels](#)).

With a latching event the contents of IC registers and 8-bit pulse accumulators are transferred to their holding registers. 8-bit pulse accumulators are cleared.

	BIT 7	6	5	4	3	2	1	BIT 0
	0	0	0	0	0	0	TCBYP	0
RESET:	0	0	0	0	0	0	0	0

**TIMTST** — Timer Test Register

**\$00AD**

Read: any time

Write: only in special mode (SMOD = 1).

**TCBYP** — Main Timer Divider Chain Bypass

0 = Normal operation

1 = For testing only. The 16-bit free-running timer counter is divided into two 8-bit halves and the prescaler is bypassed. The clock drives both halves directly.

When the high byte of timer counter TCNT (\$84) overflows from \$FF to \$00, the TOF flag in TFLG2 (\$8F) will be set.

	BIT 7	6	5	4	3	2	1	BIT 0
PORT	PT7	PT6	PT5	PT4	PT3	PT2	PT1	PT0
TIMER	I/OC7	I/OC6	I/OC5	I/OC4	I/OC3	I/OC2	I/OC1	I/OC0
RESET:	0	0	0	0	0	0	0	0

**PORTT** — Timer Port Data Register

**\$00AE**

Read: any time (inputs return pin level; outputs return data register contents)

Write: data stored in an internal latch (drives pins only if configured for output)

Since the Output Compare 7 shares the pin with Pulse Accumulator input, the only way for Pulse accumulator to receive an independent input from Output Compare 7 is setting both OM7 & OL7 to be zero, and also OC7M7 in OC7M register to be zero.

OC7 is still able to reset the counter if enabled while PT7 is used as input to Pulse Accumulator.

PORTT can be read anytime. When configured as an input, a read will return the pin level. When configured as an output, a read will return the latched output data.

**NOTE:** *Writes do not change pin state when the pin is configured for timer output. The minimum pulse width for pulse accumulator input should always be greater than the width of two module clocks due to input synchronizer circuitry. The minimum pulse width for the input capture should always be greater than the width of two module clocks due to input synchronizer circuitry.*

## Enhanced Capture Timer

	BIT 7	6	5	4	3	2	1	BIT 0
	DDT7	DDT6	DDT5	DDT4	DDT3	DDT2	DDT1	DDT0

RESET: 0 0 0 0 0 0 0 0

**DDRT** — Data Direction Register for Timer Port

**\$00AF**

Read or write any time.

0 = Configures the corresponding I/O pin for input only

1 = Configures the corresponding I/O pin for output.

The timer forces the I/O state to be an output for each timer port line associated with an enabled output compare. In these cases the data direction bits will not be changed, but have no effect on the direction of these pins. The DDRT will revert to controlling the I/O direction of a pin when the associated timer output compare is disabled. Input captures do not override the DDRT settings.

	BIT 7	6	5	4	3	2	1	BIT 0
	0	PBEN	0	0	0	0	PBOVI	0

RESET: 0 0 0 0 0 0 0 0

**PBCTL** — 16-Bit Pulse Accumulator B Control Register

**\$00B0**

Read: any time

Write: any time

16-Bit Pulse Accumulator B (PACB) is formed by cascading the 8-bit pulse accumulators PAC1 and PAC0.

When PBEN is set, the PACB is enabled. The PACB shares the input pin with IC0.

**PBEN** — Pulse Accumulator B System Enable

0 = 16-bit Pulse Accumulator system disabled. 8-bit PAC1 and PAC0 can be enabled when their related enable bits in ICPACR (\$A8) are set.

1 = Pulse Accumulator B system enabled. The two 8-bit pulse accumulators PAC1 and PAC0 are cascaded to form the PACB 16-bit pulse accumulator. When PACB is enabled, the PACN1 and PACN0 registers contents are respectively the high and low byte of the PACB.  
PA1EN and PA0EN control bits in ICPACR (\$A8) have no effect.

PBEN is independent from TEN. With timer disabled, the pulse accumulator can still function unless pulse accumulator is disabled.

PBOVI — Pulse Accumulator B Overflow Interrupt enable

0 = interrupt inhibited

1 = interrupt requested if PBOVF is set

	BIT 7	6	5	4	3	2	1	BIT 0
	0	0	0	0	0	0	PBOVF	0
RESET:	0	0	0	0	0	0	0	0

**PBFLG** — Pulse Accumulator B Flag Register

**\$00B1**

Read: any time

Write: any time

PBOVF — Pulse Accumulator B Overflow Flag

This bit is set when the 16-bit pulse accumulator B overflows from \$FFFF to \$0000, or when 8-bit pulse accumulator 1 (PAC1) overflows from \$FF to \$00.

This bit is cleared by a write to the PBFLG register with bit 1 set.

Any access to the PACN1 and PACN0 registers will clear the PBOVF flag in this register when TFFCA bit in register TSCR(\$86) is set.

## Enhanced Capture Timer

	BIT 7	6	5	4	3	2	1	BIT 0	
\$00B2	Bit 7	6	5	4	3	2	1	Bit 0	PA3H
\$00B3	Bit 7	6	5	4	3	2	1	Bit 0	PA2H
\$00B4	Bit 7	6	5	4	3	2	1	Bit 0	PA1H
\$00B5	Bit 7	6	5	4	3	2	1	Bit 0	PA0H
RESET:	0	0	0	0	0	0	0	0	

**PA3H–PA0H** — 8-Bit Pulse Accumulators Holding Registers

**\$00B2–\$00B5**

Read: any time

Write: has no effect.

These registers are used to latch the value of the corresponding pulse accumulator when the related bits in register ICPACR (\$A8) are enabled (see [Pulse Accumulators](#)).

	BIT 7	6	5	4	3	2	1	BIT 0	
\$00B6	Bit 15	14	13	12	11	10	9	Bit 8	MCCNTH
\$00B7	Bit 7	6	5	4	3	2	1	Bit 0	MCCNTL
RESET:	1	1	1	1	1	1	1	1	

**MCCNTH/L** — Modulus Down-Counter Count Register

**\$00B6, \$00B7**

Read: any time

Write: any time

A full access for the counter register should take place in one clock cycle. A separate read/write for high byte and low byte will give different result than accessing them as a word.

If the RDMCL bit in MCCTL register is cleared, reads of the MCCNT register will return the present value of the count register. If the RDMCL bit is set, reads of the MCCNT will return the contents of the load register.



If a \$0000 is written into MCCNT and modulus counter while LATQ and BUFEN in ICSYS (\$AB) register are set, the input capture and pulse accumulator registers will be latched.

With a \$0000 write to the MCCNT, the modulus counter will stay at zero and does not set the MCZF flag in MCFLG register.

If modulus mode is enabled (MODMC=1), a write to this address will update the load register with the value written to it. The count register will not be updated with the new value until the next counter underflow.

The FLMC bit in MCCTL (\$A6) can be used to immediately update the count register with the new value if an immediate load is desired.

If modulus mode is not enabled (MODMC=0), a write to this address will clear the prescaler and will immediately update the counter register with the value written to it and down-counts once to \$0000.

# Enhanced Capture Timer

Bit 7	6	5	4	3	2	1	Bit 0
Bit 15	14	13	12	11	10	9	Bit 8
Bit 7	6	5	4	3	2	1	Bit 0

**TC0H** — Timer Input Capture Holding Register 0

**\$00B8–\$00B9**

Bit 7	6	5	4	3	2	1	Bit 0
Bit 15	14	13	12	11	10	9	Bit 8
Bit 7	6	5	4	3	2	1	Bit 0

**TC1H** — Timer Input Capture Holding Register 1

**\$00BA–\$00BB**

Bit 7	6	5	4	3	2	1	Bit 0
Bit 15	14	13	12	11	10	9	Bit 8
Bit 7	6	5	4	3	2	1	Bit 0

**TC2H** — Timer Input Capture Holding Register 2

**\$00BC–\$00BD**

Bit 7	6	5	4	3	2	1	Bit 0
Bit 15	14	13	12	11	10	9	Bit 8
Bit 7	6	5	4	3	2	1	Bit 0

**TC3H** — Timer Input Capture Holding Register 3

**\$00BE–\$00BF**

Read: any time

Write: has no effect.

These registers are used to latch the value of the input capture registers TC0 – TC3. The corresponding IOSx bits in TIOS (\$80) should be cleared (see [IC Channels](#)).

## 14.5 Timer and Modulus Counter Operation in Different Modes

- STOP: Timer and modulus counter are off since clocks are stopped.
- BGDM: Timer and modulus counter keep on running, unless TSBCK (REG\$86, bit5) is set to one.
- WAIT: Counters keep on running, unless TSWAI in TSCR (\$86) is set to one.
- NORMAL: Timer and modulus counter keep on running, unless TEN in TSCR(\$86) respectively MCEN in MCCTL (\$A6) are cleared.
- TEN=0: All 16-bit timer operations are stopped, can only access the registers.
- MCEN=0: Modulus counter is stopped.
- PAEN=1: 16-bit Pulse Accumulator A is active.
- PAEN=0: 8-Bit Pulse Accumulators 3 and 2 can be enabled. (see ICPACR)
- PBEN=1: 16-bit Pulse Accumulator B is active.
- PBEN=0: 8-Bit Pulse Accumulators 1 and 0 can be enabled. (see ICPACR)



## Section 15. Multiple Serial Interface

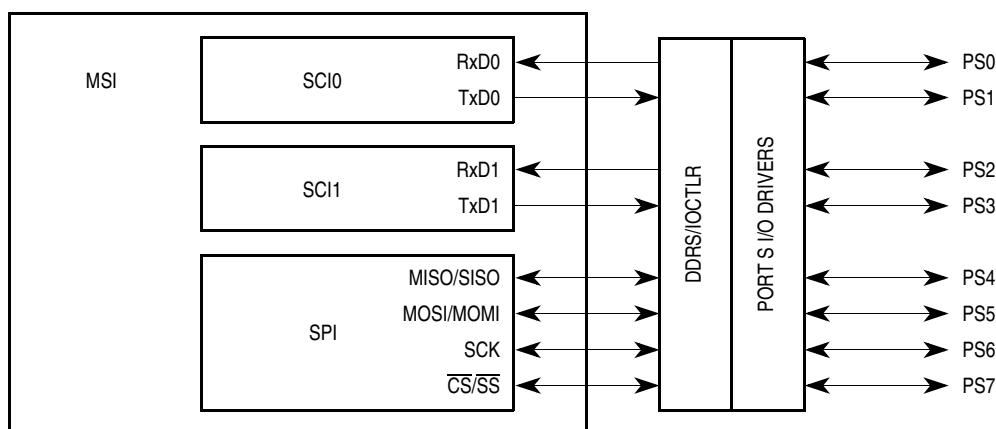
### 15.1 Contents

15.2	Introduction . . . . .	237
15.3	Block diagram . . . . .	238
15.4	Serial Communication Interface (SCI) . . . . .	238
15.5	Serial Peripheral Interface (SPI) . . . . .	250
15.6	Port S . . . . .	260

### 15.2 Introduction

The multiple serial interface (MSI) module consists of three independent serial I/O sub-systems: two serial communication interfaces (SCI0 and SCI1) and the serial peripheral interface (SPI). Each serial pin shares function with the general-purpose port pins of port S. The SCI subsystems are NRZ type systems that are compatible with standard RS-232 systems. These SCI systems have a new single wire operation mode which allows the unused pin to be available as general-purpose I/O. The SPI subsystem, which is compatible with the M68HC11 SPI, includes new features such as  $\overline{SS}$  output and bidirectional mode.

## 15.3 Block diagram

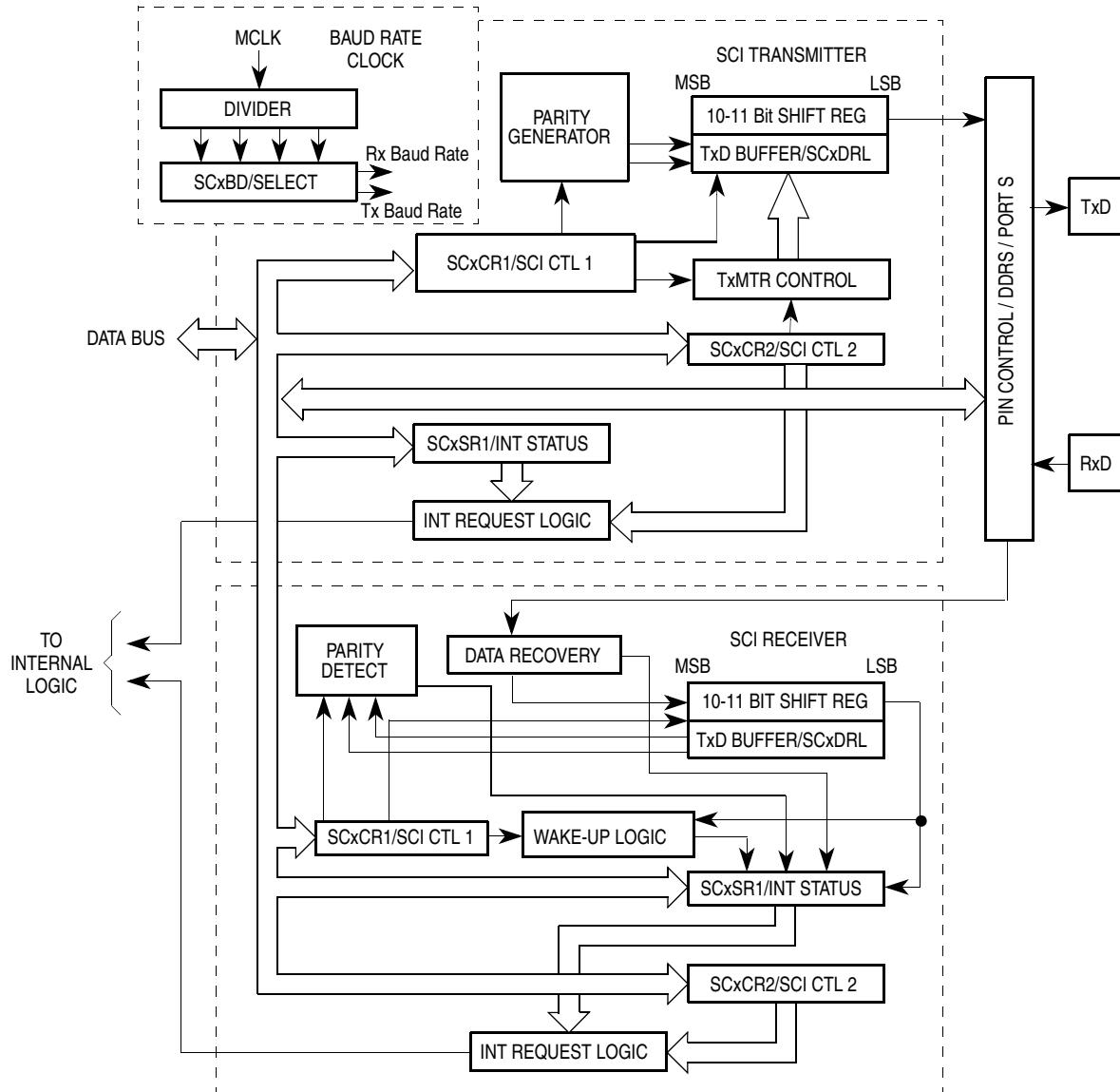


**Figure 15-1. Multiple Serial Interface Block Diagram**

## 15.4 Serial Communication Interface (SCI)

Two serial communication interfaces are available on the 68HC(9)12D60. These are NRZ format (one start, eight or nine data, and one stop bit) asynchronous communication systems with independent internal baud rate generation circuitry and SCI transmitters and receivers. They can be configured for eight or nine data bits (one of which may be designated as a parity bit, odd or even). If enabled, parity is generated in hardware for transmitted and received data. Receiver parity errors are flagged in hardware. The baud rate generator is based on a modulus counter, allowing flexibility in choosing baud rates. There is a receiver wake-up feature, an idle line detect feature, a loop-back mode, and various error detection features. Two port pins for each SCI provide the external interface for the transmitted data (TXD) and the received data (RXD).

For a faster wake-up out of WAIT mode by a received SCI message, both SCI have the capability of sending a receiver interrupt, if enabled, when RAF (receiver active flag) is set. For compatibility with other M68HC12 products, this feature is active only in WAIT mode and is disabled when VDDPLL supply is at  $V_{SS}$  level.



**Figure 15-2. Serial Communications Interface Block Diagram**

### 15.4.1 Data Format

The serial data format requires the following conditions:

- An idle-line in the high state before transmission or reception of a message.

- A start bit (logic zero), transmitted or received, that indicates the start of each character.
- Data that is transmitted or received least significant bit (LSB) first.
- A stop bit (logic one), used to indicate the end of a frame. (A frame consists of a start bit, a character of eight or nine data bits and a stop bit.)
- A BREAK is defined as the transmission or reception of a logic zero for one frame or more.
- This SCI supports hardware parity for transmit and receive.

### 15.4.2 SCI Baud Rate Generation

The basis of the SCI baud rate generator is a 13-bit modulus counter. This counter gives the generator the flexibility necessary to achieve a reasonable level of independence from the CPU operating frequency and still be able to produce standard baud rates with a minimal amount of error. The clock source for the generator comes from the M Clock.

**Table 15-1. Baud Rate Generation**

Desired SCI Baud Rate	BR Divisor for M = 4.0 MHz	BR Divisor for M = 8.0 MHz
110	2273	4545
300	833	2273
600	417	833
1200	208	417
2400	104	208
4800	52	104
9600	26	52
14400	17	35
19200	13	26
38400	—	13



### 15.4.3 SCI Register Descriptions

Control and data registers for the SCI subsystem are described below. The memory address indicated for each register is the default address that is in use after reset. Both SCI have identical control registers mapped in two blocks of eight bytes.

	Bit 7	6	5	4	3	2	1	Bit 0	
	BTST	BSPL	BRLD	SBR12	SBR11	SBR10	SBR9	SBR8	High
RESET:	0	0	0	0	0	0	0	0	

**SC0BDH/SC1BDH** — SCI Baud Rate Control Register **\$00C0/\$00C8**

	Bit 7	6	5	4	3	2	1	Bit 0	
	SBR7	SBR6	SBR5	SBR4	SBR3	SBR2	SBR1	SBR0	Low
RESET:	0	0	0	0	0	1	0	0	

**SC0BDL/SC1BDL** — SCI Baud Rate Control Register **\$00C1/\$00C9**

SCxBDH and SCxBDL are considered together as a 16-bit baud rate control register.

Read any time. Write SBR[12:0] anytime. Low order byte must be written for change to take effect. Write SBR[15:13] only in special modes. The value in SBR[12:0] determines the baud rate of the SCI. The desired baud rate is determined by the following formula:

$$\text{SCI Baud Rate} = \frac{\text{MCLK}}{16 \times \text{BR}}$$

which is equivalent to:

$$\text{BR} = \frac{\text{MCLK}}{16 \times \text{SCI Baud Rate}}$$

BR is the value written to bits SBR[12:0] to establish baud rate.

**NOTE:** *The baud rate generator is disabled until TE or RE bit in SCxCR2 register is set for the first time after reset, and/or the baud rate generator is disabled when SBR[12:0] = 0.*

## Multiple Serial Interface

BTST — Reserved for test function

BSPL — Reserved for test function

BRLD — Reserved for test function

	Bit 7	6	5	4	3	2	1	Bit 0
	LOOPS	WOMS	RSRC	M	WAKE	ILT	PE	PT
RESET:	0	0	0	0	0	0	0	0

**SC0CR1/SC1CR1** — SCI Control Register 1

**\$00C2/\$00CA**

Read or write anytime.

**LOOPS** — SCI LOOP Mode/Single Wire Mode Enable

0 = SCI transmit and receive sections operate normally.

1 = SCI receive section is disconnected from the RXD pin and the RXD pin is available as general purpose I/O. The receiver input is determined by the RSRC bit. The transmitter output is controlled by the associated DDRS bit. Both the transmitter and the receiver must be enabled to use the LOOP or the single wire mode.

If the DDRS bit associated with the TXD pin is set during the LOOPS = 1, the TXD pin outputs the SCI waveform. If the DDRS bit associated with the TXD pin is clear during the LOOPS = 1, the TXD pin becomes high (IDLE line state) for RSRC = 0 and high impedance for RSRC = 1. Refer to [Table 15-2](#).

**WOMS** — Wired-Or Mode for Serial Pins

This bit controls the two pins (TXD and RXD) associated with the SCIx section.

0 = Pins operate in a normal mode with both high and low drive capability. To affect the RXD bit, that bit would have to be configured as an output (via DDS0/2) which is the single wire case when using the SCI. WOMS bit still affects general purpose output on TXD and RXD pins when SCIx is not using these pins.

1 = Each pin operates in an open drain fashion if that pin is declared as an output.

**RSRC — Receiver Source**

When LOOPS = 1, the RSRC bit determines the internal feedback path for the receiver.

0 = Receiver input is connected to the transmitter internally (not TXD pin)

1 = Receiver input is connected to the TXD pin

**Table 15-2. Loop Mode Functions**

LOOPS	RSRC	DDSI(3)	WOMS	Function of Port S Bit 1/3
0	x	x	x	Normal Operations
1	0	0	0/1	LOOP mode without TXD output(TXD = High Impedance)
1	0	1	1	LOOP mode with TXD output (CMOS)
1	0	1	1	LOOP mode with TXD output (open-drain)
1	1	0	x	Single wire mode without TXD output (the pin is used as receiver input only, TXD = High Impedance)
1	1	1	0	Single wire mode with TXD output (the output is also fed back to receiver input, CMOS)
1	1	1	1	Single wire mode for the receiving and transmitting(open-drain)

**M — Mode (select character format)**

0 = One start, eight data, one stop bit

1 = One start, eight data, ninth data, one stop bit

**WAKE — Wake-up by Address Mark/Idle**

0 = Wake up by IDLE line recognition

1 = Wake up by address mark (last data bit set)

**ILT — Idle Line Type**

Determines which of two types of idle line detection will be used by the SCI receiver.

0 = Short idle line mode is enabled.

1 = Long idle line mode is detected.

In the short mode, the SCI circuitry begins counting ones in the search for the idle line condition immediately after the start bit. This means that the stop bit and any bits that were ones before the stop bit could be counted in that string of ones, resulting in earlier recognition of an idle line.

## Multiple Serial Interface

In the long mode, the SCI circuitry does not begin counting ones in the search for the idle line condition until a stop bit is received. Therefore, the last byte's stop bit and preceding "1" bits do not affect how quickly an idle line condition can be detected.

PE — Parity Enable

0 = Parity is disabled.

1 = Parity is enabled.

PT — Parity Type

If parity is enabled, this bit determines even or odd parity for both the receiver and the transmitter.

0 = Even parity is selected. An even number of ones in the data character causes the parity bit to be zero and an odd number of ones causes the parity bit to be one.

1 = Odd parity is selected. An odd number of ones in the data character causes the parity bit to be zero and an even number of ones causes the parity bit to be one.

	Bit 7	6	5	4	3	2	1	Bit 0
	TIE	TCIE	RIE	ILIE	TE	RE	RWU	SBK
RESET:	0	0	0	0	0	0	0	0

**SC0CR2/SC1CR2** — SCI Control Register 2

**\$00C3/\$00CB**

Read or write anytime.

TIE — Transmit Interrupt Enable

0 = TDRE interrupts disabled

1 = SCI interrupt will be requested whenever the TDRE status flag is set.

TCIE — Transmit Complete Interrupt Enable

0 = TC interrupts disabled

1 = SCI interrupt will be requested whenever the TC status flag is set.

**RIE — Receiver Interrupt Enable**

0 = RDRF and OR interrupts disabled, RAF interrupt in WAIT mode disabled

1 = SCI interrupt will be requested whenever the RDRF or OR status flag is set, or when RAF is set while in WAIT mode with VDDPLL high.

**ILIE — Idle Line Interrupt Enable**

0 = IDLE interrupts disabled

1 = SCI interrupt will be requested whenever the IDLE status flag is set.

**TE — Transmitter Enable**

0 = Transmitter disabled

1 = SCI transmit logic is enabled and the TXD pin (Port S bit 1/bit 3) is dedicated to the transmitter. The TE bit can be used to queue an idle preamble.

**RE — Receiver Enable**

0 = Receiver disabled

1 = Enables the SCI receive circuitry.

**RWU — Receiver Wake-Up Control**

0 = Normal SCI Receiver

1 = Enables the wake-up function and inhibits further receiver interrupts. Normally hardware wakes the receiver by automatically clearing this bit.

**SBK — Send Break**

0 = Break generator off

1 = Generate a break code (at least 10 or 11 contiguous zeros).

As long as SBK remains set the transmitter will send zeros. When SBK is changed to zero, the current frame of all zeros is finished before the TxD line goes to the idle state. If SBK is toggled on and off, the transmitter will send only 10 (or 11) zeros and then revert to mark idle or sending data.

## Multiple Serial Interface

	Bit 7	6	5	4	3	2	1	Bit 0
	TDRE	TC	RDRF	IDLE	OR	NF	FE	PF
RESET:	1	1	0	0	0	0	0	0

**SC0SR1/SC1SR1** — SCI Status Register 1 **\$00C4/\$00CC**

The bits in these registers are set by various conditions in the SCI hardware and are automatically cleared by special acknowledge sequences. The receive related flag bits in SCxSR1 (RDRF, IDLE, OR, NF, FE, and PF) are all cleared by a read of the SCxSR1 register followed by a read of the transmit/receive data register low byte. However, only those bits which were set when SCxSR1 was read will be cleared by the subsequent read of the transmit/receive data register low byte. The transmit related bits in SCxSR1 (TDRE and TC) are cleared by a read of the SCxSR1 register followed by a write to the transmit/receive data register low byte.

Read anytime (used in auto clearing mechanism). Write has no meaning or effect.

### TDRE — Transmit Data Register Empty Flag

New data will not be transmitted unless SCxSR1 is read before writing to the transmit data register. Reset sets this bit.

0 = SCxDR busy

1 = Any byte in the transmit data register is transferred to the serial shift register so new data may now be written to the transmit data register.

### TC — Transmit Complete Flag

Flag is set when the transmitter is idle (no data, preamble, or break transmission in progress). Clear by reading SCxSR1 with TC set and then writing to SCxDR.

0 = Transmitter busy

1 = Transmitter is idle

#### RDRF — Receive Data Register Full Flag

Once cleared, IDLE is not set again until the RxD line has been active and becomes idle again. RDRF is set if a received character is ready to be read from SCxDR. Clear the RDRF flag by reading SCxSR1 with RDRF set and then reading SCxDR.

- 0 = SCxDR empty
- 1 = SCxDR full

#### IDLE — Idle Line Detected Flag

Receiver idle line is detected (the receipt of a minimum of 10/11 consecutive ones). This bit will not be set by the idle line condition when the RWU bit is set. Once cleared, IDLE will not be set again until after RDRF has been set (after the line has been active and becomes idle again).

- 0 = RxD line is idle
- 1 = RxD line is active

#### OR — Overrun Error Flag

New byte is ready to be transferred from the receive shift register to the receive data register and the receive data register is already full (RDRF bit is set). Data transfer is inhibited until this bit is cleared.

- 0 = No overrun
- 1 = Overrun detected

#### NF — Noise Error Flag

Set during the same cycle as the RDRF bit but not set in the case of an overrun (OR).

- 0 = Unanimous decision
- 1 = Noise on a valid start bit, any of the data bits, or on the stop bit

#### FE — Framing Error Flag

Set when a zero is detected where a stop bit was expected. Clear the FE flag by reading SCxSR1 with FE set and then reading SCxDR.

- 0 = Stop bit detected
- 1 = Zero detected rather than a stop bit

## Multiple Serial Interface

### PF — Parity Error Flag

Indicates if received data's parity matches parity bit. This feature is active only when parity is enabled. The type of parity tested for is determined by the PT (parity type) bit in SCxCR1.

0 = Parity correct

1 = Incorrect parity detected

	Bit 7	6	5	4	3	2	1	Bit 0
	SCSWAI	MIE <sup>(1)</sup>	MDL1 <sup>(1)</sup>	MDL0 <sup>(1)</sup>	0	0	0	RAF
RESET:	0	0	0	0	0	0	0	0

### SC0SR2 — SCI Status Register 2

**\$00C5/\$00CD**

1. See [Motorola Interconnect Bus](#) for descriptions of these bits.

Read anytime. Write has no meaning or effect.

### SCSWAI — Serial Communications Interface Stop in WAIT Mode

0 = SCI clock operates normally.

1 = Halt SCI clock generation when in WAIT mode.

### RAF — Receiver Active Flag

This bit is controlled by the receiver front end. It is set during the RT1 time period of the start bit search. It is cleared when an idle state is detected or when the receiver circuitry detects a false start bit (generally due to noise or baud rate mismatch).

0 = A character is not being received

1 = A character is being received

If enabled with RIE = 1, RAF set generates an interrupt when VDDPLL is high.



Bit 7	6	5	4	3	2	1	Bit 0
R8	T8	0	0	0	0	0	0

RESET: — — — — — — — —

**SC0DRH/SC1DRH** — SCI Data Register High **\$00C6/\$00CE**

Bit 7	6	5	4	3	2	1	Bit 0
R7/T7	R6/T6	R5/T5	R4/T4	R3/T3	R2/T2	R1/T1	R0/T0

RESET: — — — — — — — —

**SC0DRL/SC1DRL** — SCI Data Register Low **\$00C7/\$00CF**

#### R8 — Receive Bit 8

Read anytime. Write has no meaning or affect.

This bit is the ninth serial data bit received when the SCI system is configured for nine-data-bit operation.

#### T8 — Transmit Bit 8

Read or write anytime.

This bit is the ninth serial data bit transmitted when the SCI system is configured for nine-data-bit operation. When using 9-bit data format this bit does not have to be written for each data word. The same value will be transmitted as the ninth bit until this bit is rewritten.

#### R7/T7–R0/T0 — Receive/Transmit Data Bits 7 to 0

Reads access the eight bits of the read-only SCI receive data register (RDR). Writes access the eight bits of the write-only SCI transmit data register (TDR). SCxDRL:SCxDRH form the 9-bit data word for the SCI. If the SCI is being used with a 7- or 8-bit data word, only SCxDRL needs to be accessed. If a 9-bit format is used, the upper register should be written first to ensure that it is transferred to the transmitter shift register with the lower register.

### 15.5 Serial Peripheral Interface (SPI)

The serial peripheral interface allows the 68HC(9)12D60 to communicate synchronously with peripheral devices and other microprocessors. The SPI system in the 68HC(9)12D60 can operate as a master or as a slave. The SPI is also capable of interprocessor communications in a multiple master system.

When the SPI is enabled, all pins that are defined by the configuration as inputs will be inputs regardless of the state of the DDRS bits for those pins. All pins that are defined as SPI outputs will be outputs only if the DDRS bits for those pins are set. Any SPI output whose corresponding DDRS bit is cleared can be used as a general-purpose input.

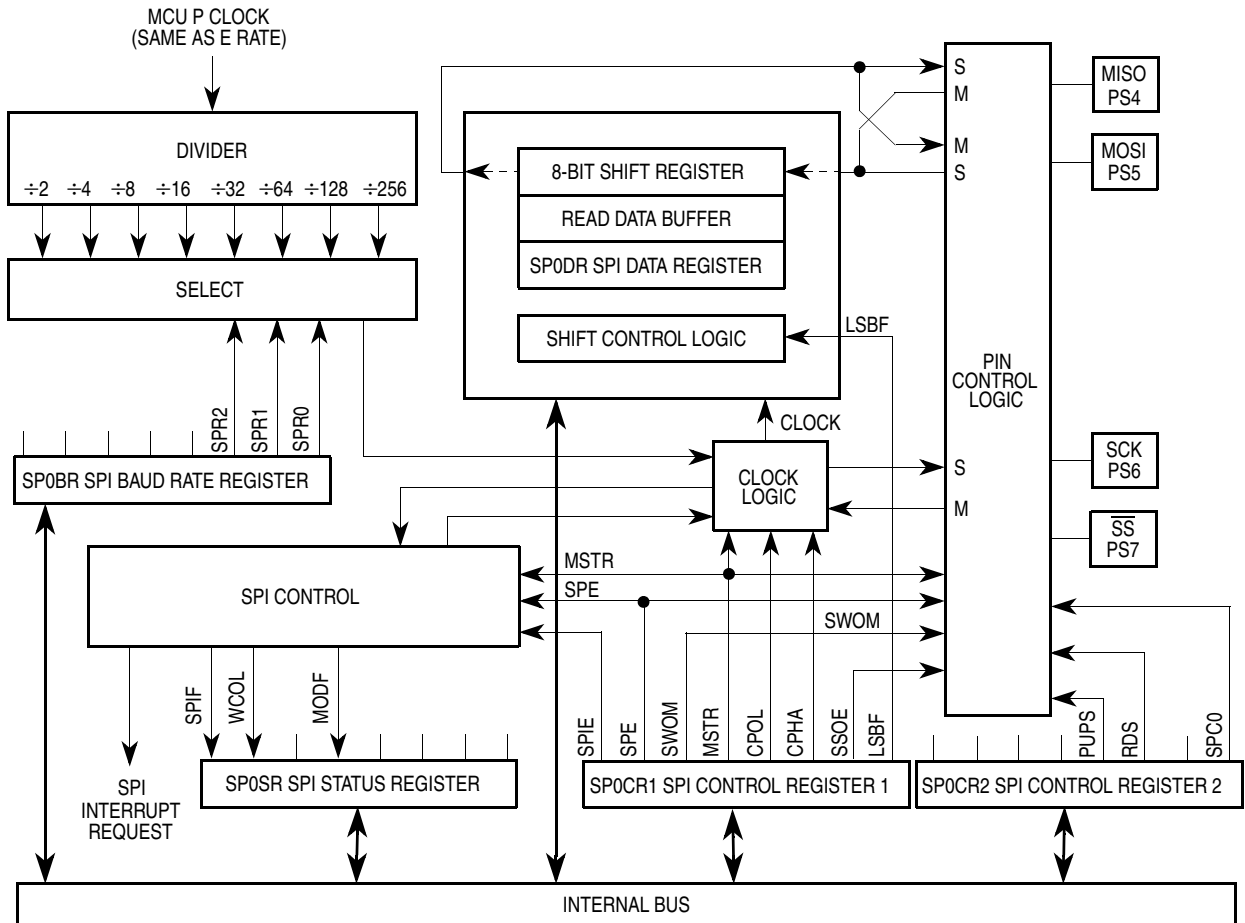
A bidirectional serial pin is possible using the DDRS as the direction control.

#### 15.5.1 SPI Baud Rate Generation

The E Clock is input to a divider series and the resulting SPI clock rate may be selected to be E divided by 2, 4, 8, 16, 32, 64, 128 or 256. Three bits in the SP0BR register control the SPI clock rate. This baud rate generator is activated only when SPI is in the master mode and serial transfer is taking place. Otherwise this divider is disabled to save power.

#### 15.5.2 SPI Operation

In the SPI system the 8-bit data register in the master and the 8-bit data register in the slave are linked to form a distributed 16-bit register. When a data transfer operation is performed, this 16-bit register is serially shifted eight bit positions by the SCK clock from the master so the data is effectively exchanged between the master and the slave. Data written to the SP0DR register of the master becomes the output data for the slave and data read from the SP0DR register of the master after a transfer operation is the input data from the slave.



**Figure 15-3. Serial Peripheral Interface Block Diagram**

A clock phase control bit (CPHA) and a clock polarity control bit (CPOL) in the SP0CR1 register select one of four possible clock formats to be used by the SPI system. The CPOL bit simply selects non-inverted or inverted clock. The CPHA bit is used to accommodate two fundamentally different protocols by shifting the clock by one half cycle or no phase shift.

# Multiple Serial Interface

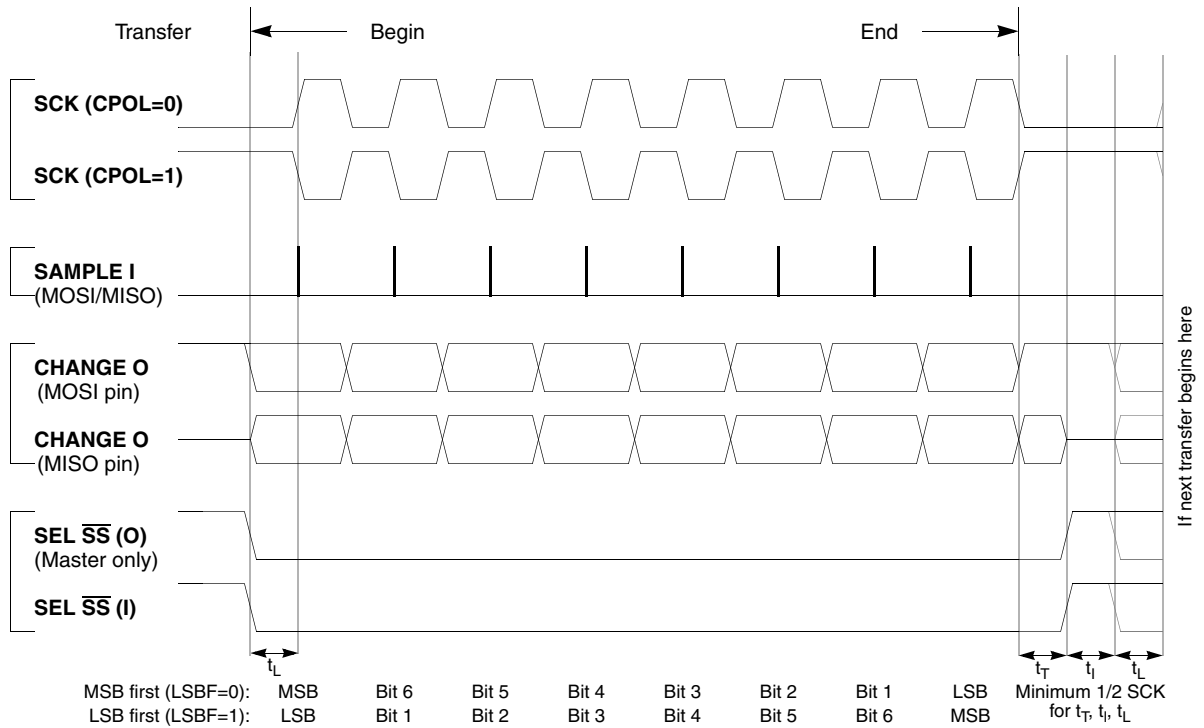


Figure 15-4. SPI Clock Format 0 (CPHA = 0)

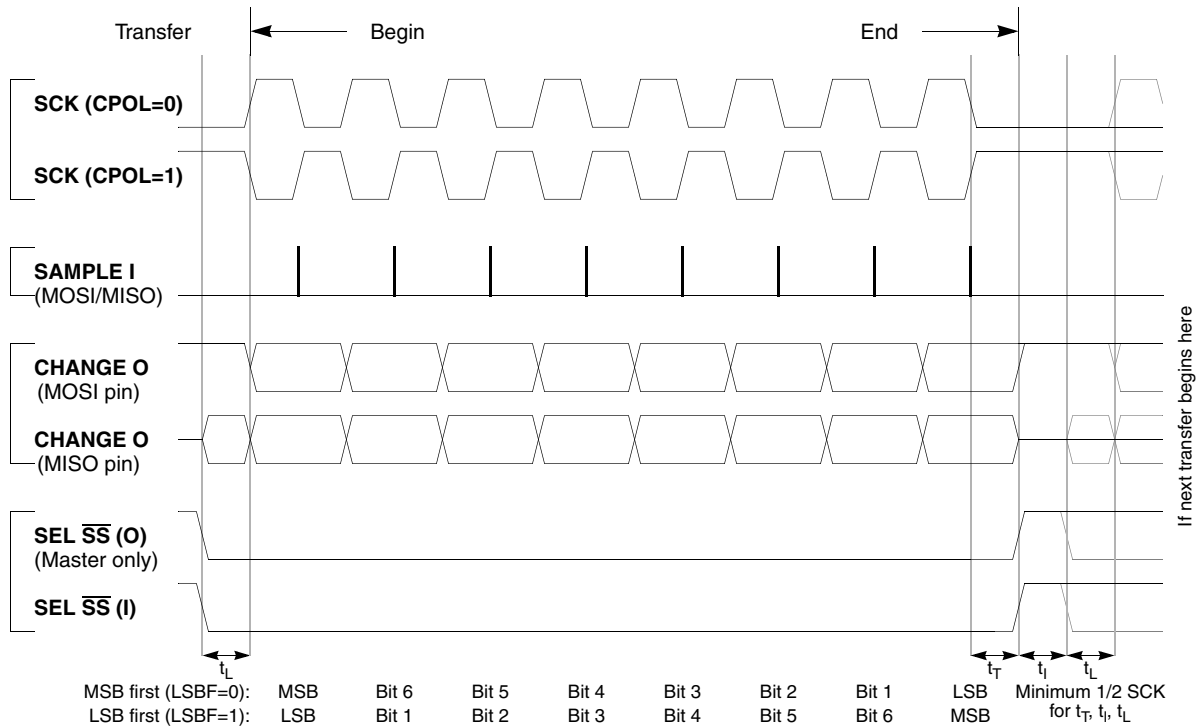


Figure 15-5. SPI Clock Format 1 (CPHA = 1)

### 15.5.3 $\overline{SS}$ Output

Available in master mode only,  $\overline{SS}$  output is enabled with the SSOE bit in the SP0CR1 register if the corresponding DDORS is set. The  $\overline{SS}$  output pin will be connected to the  $\overline{SS}$  input pin of the external slave device. The  $\overline{SS}$  output automatically goes low for each transmission to select the external device and it goes high during each idling state to deselect external devices.

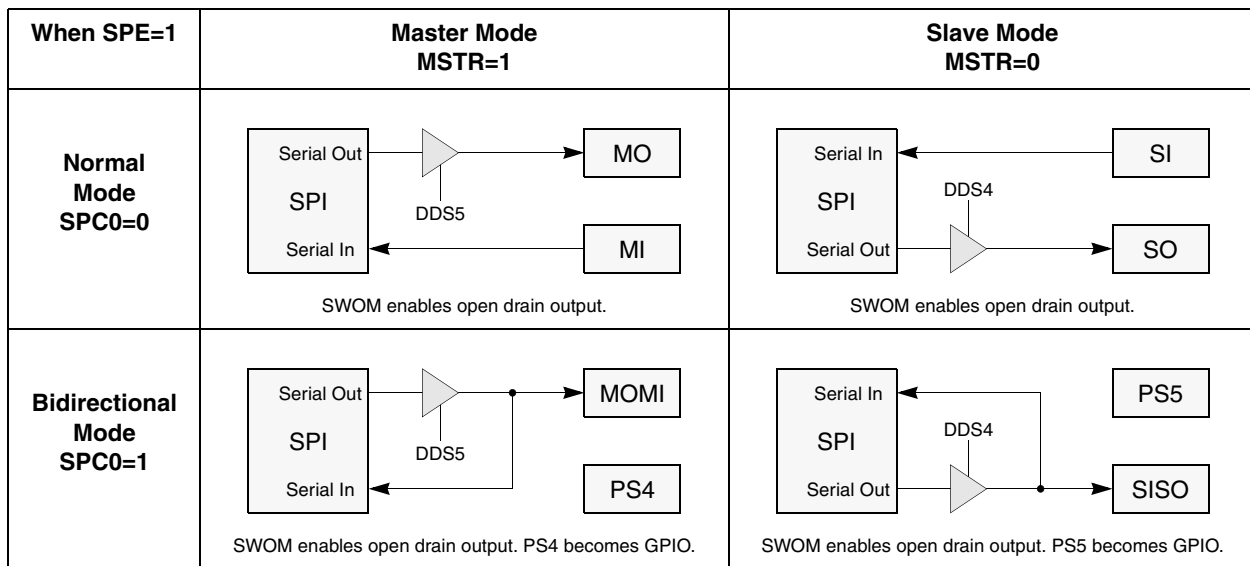
Table 15-3.  $\overline{SS}$  Output Selection

DDS7	SSOE	Master Mode	Slave Mode
0	0	SS Input with MODF Feature	SS Input
0	1	Reserved	SS Input
1	0	General-Purpose Output	SS Input
1	1	SS Output	SS Input

# Multiple Serial Interface

## 15.5.4 Bidirectional Mode (MOMI or SISO)

In bidirectional mode, the SPI uses only one serial data pin for external device interface. The MSTR bit decides which pin to be used. The MOSI pin becomes serial data I/O (MOMI) pin for the master mode, and the MISO pin becomes serial data I/O (SISO) pin for the slave mode. The direction of each serial I/O pin depends on the corresponding DDRS bit.



**Figure 15-6. Normal Mode and Bidirectional Mode**

### 15.5.5 Register Descriptions

Control and data registers for the SPI subsystem are described below. The memory address indicated for each register is the default address that is in use after reset. For more information refer to [Operating Modes and Resource Mapping](#).

	Bit 7	6	5	4	3	2	1	Bit 0
	SPIE	SPE	SWOM	MSTR	CPOL	CPHA	SSOE	LSBF
RESET:	0	0	0	0	0	1	0	0

**SP0CR1** — SPI Control Register 1 **\$00D0**

Read or write anytime.

**SPIE** — SPI Interrupt Enable

0 = SPI interrupts are inhibited

1 = Hardware interrupt sequence is requested each time the SPIF or MODF status flag is set

**SPE** — SPI System Enable

0 = SPI internal hardware is initialized and SPI system is in a low-power disabled state.

1 = PS[4:7] are dedicated to the SPI function

When MODF is set, SPE always reads zero. SP0CR1 must be written as part of a mode fault recovery sequence.

**SWOM** — Port S Wired-OR Mode

Controls not only SPI output pins but also the general-purpose output pins (PS[4:7]) which are not used by SPI.

0 = SPI and/or PS[4:7] output buffers operate normally

1 = SPI and/or PS[4:7] output buffers behave as open-drain outputs

**MSTR** — SPI Master/Slave Mode Select

0 = Slave mode

1 = Master mode

## Multiple Serial Interface

### CPOL, CPHA — SPI Clock Polarity, Clock Phase

These two bits are used to specify the clock format to be used in SPI operations. When the clock polarity bit is cleared and data is not being transferred, the SCK pin of the master device is low. When CPOL is set, SCK idles high. See [Figure 15-4](#) and [Figure 15-5](#).

### SSOE — Slave Select Output Enable

The  $\overline{SS}$  output feature is enabled only in the master mode by asserting the SSOE and DDS7.

### LSBF — SPI LSB First enable

0 = Data is transferred most significant bit first

1 = Data is transferred least significant bit first

Normally data is transferred most significant bit first. This bit does not affect the position of the MSB and LSB in the data register. Reads and writes of the data register will always have MSB in bit 7.

	Bit 7	6	5	4	3	2	1	Bit 0
	0	0	0	0	0	0	SPSWAI	SPC0
RESET:	0	0	0	0	0	0	0	0

**SP0CR2** — SPI Control Register 2

**\$00D1**

Read or write anytime.

### SPSWAI — Serial Interface Stop in WAIT mode

0 = Serial interface clock operates normally

1 = Halt serial interface clock generation in WAIT mode



### SPC0 — Serial Pin Control 0

This bit decides serial pin configurations with MSTR control bit.

Pin Mode		SPC0 <sup>(1)</sup>	MSTR	MISO <sup>(2)</sup>	MOSI <sup>(3)</sup>	SCK <sup>(4)</sup>	SS <sup>(5)</sup>
#1	Normal	0	0	Slave Out	Slave In	SCK In	SS In
#2			1	Master In	Master Out	SCK Out	SS I/O
#3	Bidirectional	1	0	Slave I/O	GPI/O	SCK In	SS In
#4			1	GPI/O	Master I/O	SCK Out	SS I/O

1. The serial pin control 0 bit enables bidirectional configurations.
2. Slave output is enabled if DDS4 = 1, SS = 0 and MSTR = 0. (#1, #3)
3. Master output is enabled if DDS5 = 1 and MSTR = 1. (#2, #4)
4. SCK output is enabled if DDS6 = 1 and MSTR = 1. (#2, #4)
5. SS output is enabled if DDS7 = 1, SSOE = 1 and MSTR = 1. (#2, #4)

Bit 7	6	5	4	3	2	1	Bit 0
0	0	0	0	0	SPR2	SPR1	SPR0

RESET: 0 0 0 0 0 0 0 0

**SP0BR** — SPI Baud Rate Register

**\$00D2**

Read anytime. Write anytime.

At reset, E Clock divided by 2 is selected.

SPR[2:0] — SPI Clock (SCK) Rate Select Bits

These bits are used to specify the SPI clock rate.

**Table 15-4. SPI Clock Rate Selection**

SPR2	SPR1	SPR0	E Clock Divisor	Frequency at E Clock = 4 MHz	Frequency at E Clock = 8 MHz
0	0	0	2	2.0 MHz	4.0 MHz
0	0	1	4	1.0 MHz	2.0 MHz
0	1	0	8	500 kHz	1.0 MHz
0	1	1	16	250 kHz	500 KHz
1	0	0	32	125 kHz	250 KHz
1	0	1	64	62.5 kHz	125 KHz
1	1	0	128	31.3 kHz	62.5 KHz
1	1	1	256	15.6 kHz	31.3 KHz

## Multiple Serial Interface

Bit 7	6	5	4	3	2	1	Bit 0
SPIF	WCOL	0	MODF	0	0	0	0

RESET:      0      0      0      0      0      0      0      0

**SP0SR** — SPI Status Register

**\$00D3**

Read anytime. Write has no meaning or effect.

### SPIF — SPI Interrupt Request

SPIF is set after the eighth SCK cycle in a data transfer and it is cleared by reading the SP0SR register (with SPIF set) followed by an access (read or write) to the SPI data register.

### WCOL — Write Collision Status Flag

The MCU write is disabled to avoid writing over the data being transferred. No interrupt is generated because the error status flag can be read upon completion of the transfer that was in progress at the time of the error. Automatically cleared by a read of the SP0SR (with WCOL set) followed by an access (read or write) to the SP0DR register.

0 = No write collision

1 = Indicates that a serial transfer was in progress when the MCU tried to write new data into the SP0DR data register.

### MODF — SPI Mode Error Interrupt Status Flag

This bit is set automatically by SPI hardware if the MSTR control bit is set and the slave select input pin becomes zero. This condition is not permitted in normal operation. In the case where DD<sub>RS</sub> bit 7 is set, the PS7 pin is a general-purpose output pin or  $\overline{SS}$  output pin rather than being dedicated as the  $\overline{SS}$  input for the SPI system. In this special case the mode fault function is inhibited and MODF remains cleared. This flag is automatically cleared by a read of the SP0SR (with MODF set) followed by a write to the SP0CR1 register.



**SP0DR** — SPI Data Register

**\$00D5**

Read anytime (normally only after SPIF flag set). Write anytime (see WCOL write collision flag).

Reset does not affect this address.

This 8-bit register is both the input and output register for SPI data. Reads of this register are double buffered but writes cause data to be written directly into the serial shifter. In the SPI system the 8-bit data register in the master and the 8-bit data register in the slave are linked by the MOSI and MISO wires to form a distributed 16-bit register. When a data transfer operation is performed, this 16-bit register is serially shifted eight bit positions by the SCK clock from the master so the data is effectively exchanged between the master and the slave. Note that some slave devices are very simple and either accept data from the master without returning data to the master or pass data to the master without requiring data from the master.

## 15.6 Port S

In all modes, port S bits PS[7:0] can be used for either general-purpose I/O, or with the SCI and SPI subsystems. During reset, port S pins are configured as high-impedance inputs (DDRS is cleared).

**PORTS** — Port S Data Register

**\$00D6**

	Bit 7	6	5	4	3	2	1	Bit 0
	PS7	PS6	PS5	PS4	PS3	PS2	PS1	PS0
Pin Function	$\overline{SS}$ CS	SCK	MOSI MOMI	MISO SISO	TXD1	RXD1	TXD0	RXD0

Read anytime (inputs return pin level; outputs return pin driver input level). Write data stored in internal latch (drives pins only if configured for output). Writes do not change pin state when pin configured for SPI or SCI output.

After reset all bits are configured as general-purpose inputs.

Port S shares function with the on-chip serial systems (SPI and SCI0/1).

	Bit 7	6	5	4	3	2	1	Bit 0
	DDS7	DDS6	DDS5	DDS4	DDS3	DDS2	DDS1	DDS0
RESET:	0	0	0	0	0	0	0	0

**DDRS** — Data Direction Register for Port S

**\$00D7**

Read or write anytime.

After reset, all general-purpose I/O are configured for input only.

0 = Configure the corresponding I/O pin for input only

1 = Configure the corresponding I/O pin for output

**DDS2, DDS0** — Data Direction for Port S Bit 2 and Bit 0

If the SCI receiver is configured for two-wire SCI operation, corresponding port S pins will be input regardless of the state of these bits.

DDS3, DDS1 — Data Direction for Port S Bit 3 and Bit 1

If the SCI transmitter is configured for two-wire SCI operation, corresponding port S pins will be output regardless of the state of these bits.

DDS[6:4] — Data Direction for Port S Bits 6 through 4

If the SPI is enabled and expects the corresponding port S pin to be an input, it will be an input regardless of the state of the DDRS bit. If the SPI is enabled and expects the bit to be an output, it will be an output ONLY if the DDRS bit is set.

DDS7 — Data Direction for Port S Bit 7

In SPI slave mode, DDRS7 has no meaning or effect; the PS7 pin is dedicated as the  $\overline{SS}$  input. In SPI master mode, DDRS7 determines whether PS7 is an error detect input to the SPI or a general-purpose or slave select output line.

**NOTE:** *If mode fault error occurs, bits 5, 6 and 7 are forced to zero.*

## Multiple Serial Interface

	Bit 7	6	5	4	3	2	1	Bit 0
	0	RDPS2	RDPS1	RDPS0	0	PUPS2	PUPS1	PUPS0
RESET:	0	0	0	0	0	0	0	0

**PURDS** — Pull-Up Register for Port S

**\$00D9**

**RDPS2** — Reduce Drive of Port S[7:4]

0 = Port S[7:4] output drivers operate normally

1 = Port S[7:4] output pins have reduced drive capability for lower power and less noise

**RDPS1** — Reduce Drive of Port S[3:2]

0 = Port S[3:2] output drivers operate normally

1 = Port S[3:2] output pins have reduced drive capability for lower power and less noise

**RDPS0** — Reduce Drive of Port S[1:0]

0 = Port S[1:0] output drivers operate normally

1 = Port S[1:0] output pins have reduced drive capability for lower power and less noise

**PUPS2** — Pull-up Port S[7:4] Enable

0 = No internal pull-ups on port S[7:4]

1 = Port S[7:4] input pins have an active pull-up device. If a pin is programmed as output, the pull-up device becomes inactive.

**PUPS1** — Pull-up Port S[3:2] Enable

0 = No internal pull-ups on port S[3:2]

1 = Port S[3:2] input pins have an active pull-up device. If a pin is programmed as output, the pull-up device becomes inactive.

**PUPS0** — Pull-up Port S[1:0] Enable

0 = No internal pull-ups on port S[1:0]

1 = Port S[1:0] input pins have an active pull-up device. If a pin is programmed as output, the pull-up device becomes inactive.

## Section 16. Motorola Interconnect Bus

### 16.1 Contents

16.2	Introduction . . . . .	263
16.3	Push-pull sequence . . . . .	264
16.4	Biphase coding . . . . .	265
16.5	Message validation . . . . .	266
16.6	Interfacing to MI Bus . . . . .	268
16.7	MI Bus clock rate . . . . .	270
16.8	SCI0/MI Bus registers . . . . .	270

### 16.2 Introduction

The Motorola Interconnect Bus (MI Bus) is a serial communications protocol which supports distributed real-time control efficiently and with a high degree of noise immunity, at a typical data transfer bit rate of 20kHz. The MI Bus is suitable for medium speed networks requiring very low cost multiplex wiring; only one wire is required to connect to slave devices.<sup>(1)</sup>

The MI Bus uses a push-pull sequence to transfer data. The master device, which in this case is the 68HC(9)12D60, sends a push field to the slave devices connected to the bus. The push field contains data plus an address that is recognized by one of the slaves. The slave addressed returns data which the master pulls from the MI Bus over the same wire. Specific details of the message format are covered later in this section.

---

1. Related information on Motorola's MI Bus is contained in the following Motorola publications:  
*EB409/D — The MI Bus and Product family for Multiplexing Systems*  
*AN475/D — Single Wire MI Bus Controlling Stepper Motors*  
*BR477/D — Smart Mover – Stepper Motors with Integrated Serial Bus Controller*

The MCU (master) can take the bus at any time, with a start bit that violates the rules of Manchester biphasc encoding. Up to eight slave devices may be addressed by the MI Bus. Other features of MI Bus include message validation, error detection, and default value setting.

On the 68HC(9)12D60 the MI Bus module shares the same pins on port S as the SCI0 module. Data is transmitted (or 'pushed') via the TxD0 pin, and received ('pulled') via the RxD0 pin. While data is being pushed, RxD0 will be disconnected from the receiver circuitry. The message frame is handled automatically in hardware. The MCU register interface is similar to that for the SCI.

## 16.3 Push-pull sequence

Communication between the MCU and the slave device always utilizes the same frame organization. First, the MCU sends serial data to the selected device. This data field is called the 'push field'. At the end of the push field, the selected device automatically sends back to the MCU the data held during the push sequence. The MCU reads the serial data sent by the selected device. This data is called the 'pull field' and contains status information followed by the end-of-frame information from the selected device.

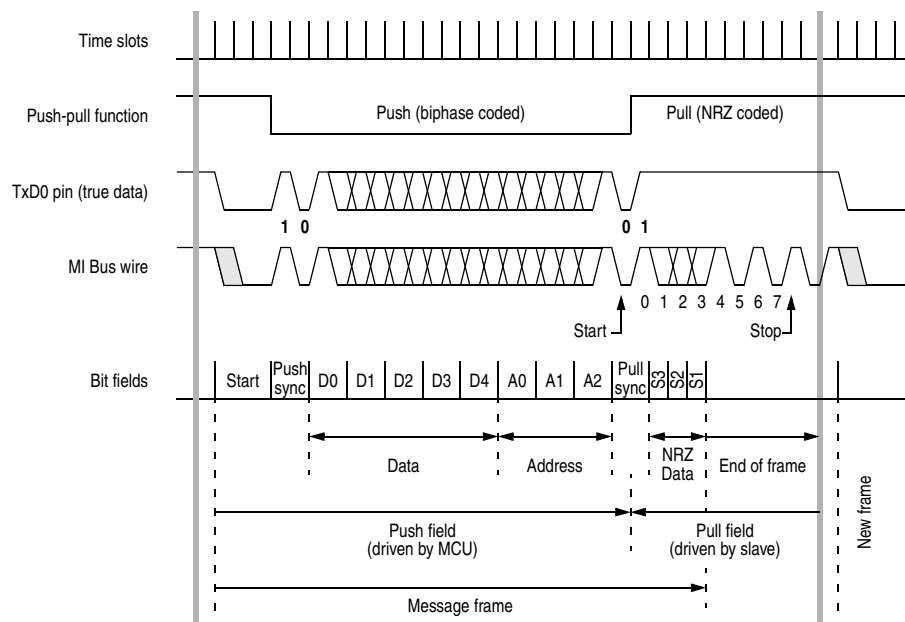


Figure 16-1. MI Bus timing



### 16.3.1 The push field

The push field consists of a start bit, a push synchronization bit, a push data field and a push address field. The start consists of three time slots having the dominant logical state '0'. The start marks the beginning of the message frame by violation of the rule of the Manchester code. The push synchronization bit consists of a biphase coded '0'. Biphase coding will be discussed later. The push data field consists of five bits of biphase coded data. The push address consists of three bits of biphase coded data. Data and address are written to the lower byte of the SCI data register (SC0DRL). The push data occupies the lower five bits and the push address occupies the upper three bits of the register.

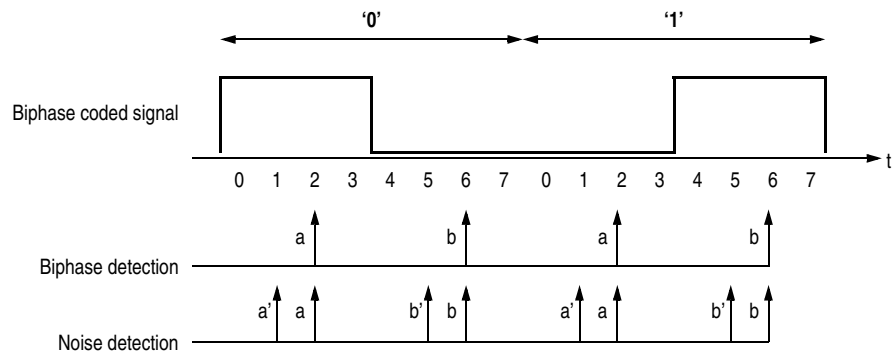
### 16.3.2 The pull field

The pull field consists of a pull synchronization bit, a pull data field and an end of frame. The pull synchronization bit is a biphase coded '1' and is initiated by the MCU during the time slot after the last address bit of the push field. The pull data field consists of an NRZ coded transmission, each bit taking one time slot. Once shifted in, the pull data is stored in the lower byte of the SCI data register (SC0DRL). The end-of-frame field is a square wave signal having a typical frequency of  $20\text{kHz} \pm 1\%$  tolerance (i.e. the bit rate of the push field) when the data sent to the selected device is valid.

## 16.4 Biphase coding

Manchester biphase L coding is used for the push field bits. Each bit requires two time slots to encode the logic value of the bit. This encoding allows the detection of a single error at the time slot level. Bits are encoded as follows:

- 0 = In the first time slot, the logic level is set to one, followed by a logic level zero in the second time slot.
- 1 = In the first time slot, the logic level is set to zero, followed by a logic level one in the second time slot.



**Figure 16-2. Biphase coding and error detection**

## 16.5 Message validation

The communication between the MCU and the selected device is valid when the MCU reads a pull data field having correct codes (excluding the codes '111' and '000') followed by a square wave signal, having a frequency of 20kHz, contained in the end-of-frame information.

An MI Bus error is detected when the pull field contains the code '111' followed by the end-of-frame permanently tied to logical state '1'. This means that the communication between the MCU and the selected device was not accomplished.

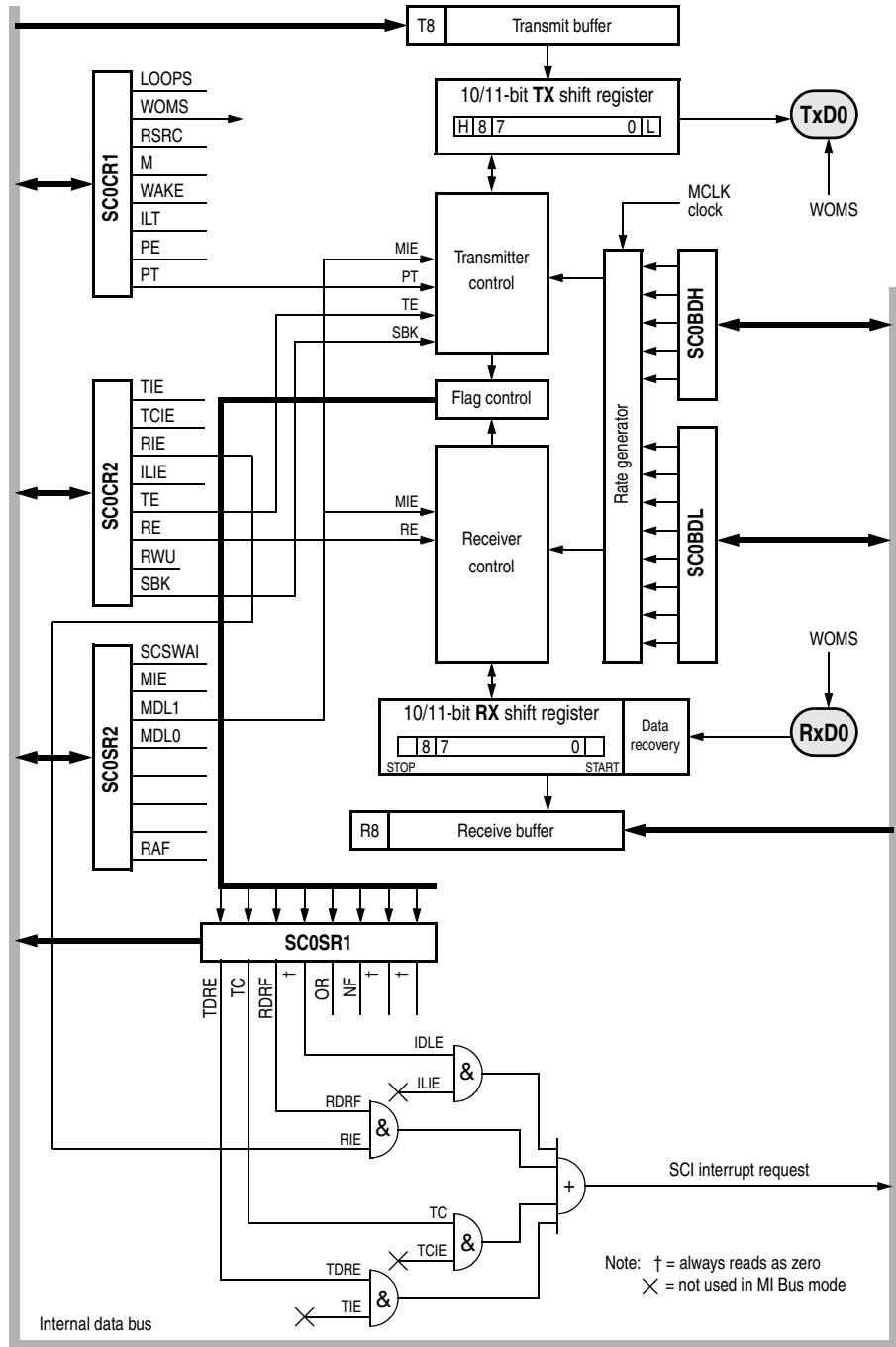


Figure 16-3. MI BUS Block Diagram

### 16.5.1 Controller detected errors

There are three different MI Bus error types which are detected by the selected slave device and are not mutually exclusive. The MCU cannot determine which error occurred.

**Noise error** — Slave devices take two samples in each time slot of the biphasic encoded push field. An error occurs when the two samples for each time slot are not the same logical level.

**Biphase error** — Slave devices receiving the push field detect the biphasic code. An error occurs when the two time slots of the biphasic code do not yield a logical exclusive-OR function.

**Field error** — A field error is detected when the fixed-form of the push field is violated.

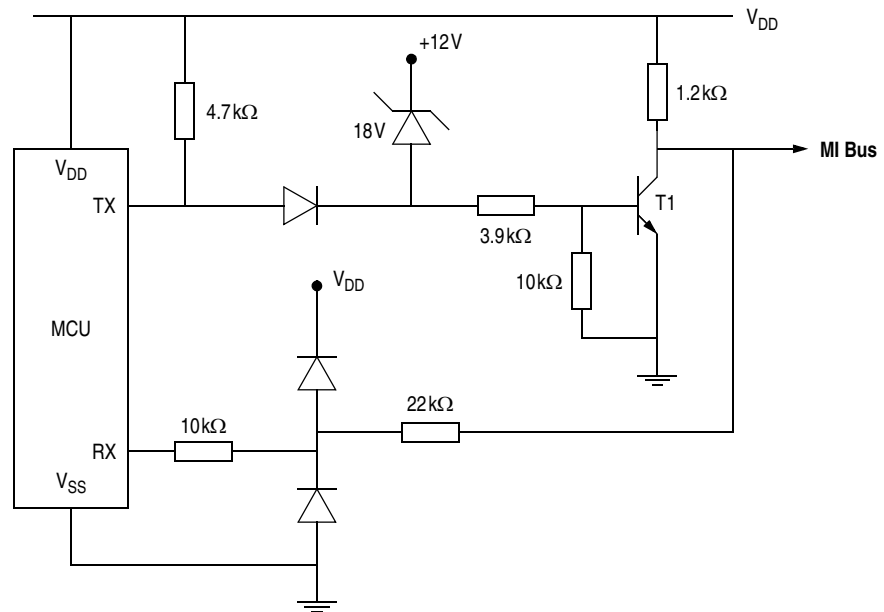
### 16.5.2 MCU detected errors

There is a fourth error that can be detected by the MCU. This error causes the noise flag (NF) to be asserted in the SC0SR1 register during the push field sequence.

**Bit error** — A bit error can be detected by the MCU during the push field. The MI Bus serial system monitors the bus via on-chip hardware at the RxD0 pin at the same time as sending data. A bit error is detected at that bit time when the value monitored is different from the bit value sent.

## 16.6 Interfacing to MI Bus

Physically the MI Bus consists of only a single wire. In the example shown in [Figure 16-4](#), only a single transistor and a few passive components are required to connect up the 68HC(9)12D60 for full MI Bus operation.



**Figure 16-4. A typical MI Bus interface**

The transistor serves both to drive the MI Bus during the push field and to protect the MCU TX pin from voltage transients generated in the wiring. Without the transistor, EMI could damage the TX pin. Similarly, the input pin (RX) is protected from EMI by clamping it to the MCU supply rails with two diodes. When a load dump occurs, the zener diode (18V) is switched on and hence turns the transistor on; this generates the logic '0' state on the MI Bus. After eight time slots (200ms) of continuous '0' state, all devices on the MI Bus will have their outputs disabled.

The MI Bus line can take two states, recessive or dominant. The dominant state ('0') is represented by a maximum 0.3V ( $V_{CESAT}$  of the transistor, T1). The recessive state ('1') is represented by 5V, through a pull-up resistor of 10k $\Omega$ .

The bus load depends on the number of devices on the bus. Each device has a pull-up resistor of 10k $\Omega$ . An external termination resistor is used to stabilize the load resistance of the bus at 600 $\Omega$ .

## 16.7 MI Bus clock rate

The MI Bus clock rate is set via the SCI baud registers. To use the MI Bus, the MCLK clock frequency that drives the SCI clock generator must be selected to match the minimum resolution of the MI Bus logic. This is expressed by the following formula:

$$MCLK = 16 \cdot n \cdot (2 \cdot Push\_field\_bit\_rate) = 16 \cdot n \cdot 40kHz = n \cdot 640kHz$$

where 'n' is an integer and 20kHz is the minimum Push field bit rate for the MI Bus. Values for MCLK could be 640kHz, 1280kHz, 1920kHz, ..., n • 640kHz. The value 'n' is the modulus for the MI Bus baud register. MCLK may be the output of the PLL circuit or it may be the EXTAL/2 input of the MCU. Refer to [Clock Divider Chains](#).

## 16.8 SCI0/MI Bus registers

MI Bus operation is controlled by the same group of registers as is used for the SCI. However the functions of some of the bits are modified when in MI Bus mode. A description of the registers, as applicable to the MI Bus function, is given here.

In MI Bus mode, bits that have no meaning are reserved by Motorola, and are not described.

	Bit 7	6	5	4	3	2	1	Bit 0	
	BTST	BSPPL	BRLD	SBR12	SBR11	SBR10	SBR9	SBR8	High
RESET:	0	0	0	0	0	0	0	0	
<b>SC0BDH</b> — MI Bus Clock Rate Control Register									<b>\$00C0</b>

	Bit 7	6	5	4	3	2	1	Bit 0	
	SBR7	SBR6	SBR5	SBR4	SBR3	SBR2	SBR1	SBR0	Low
RESET:	0	0	0	0	0	1	0	0	
<b>SC0BDL</b> — MI Bus Clock Rate Control Register									<b>\$00C1</b>

SC0BDH and SC0BDL are considered together as a 16-bit baud rate control register.

Read any time. Write SBR[12:0] anytime. Low order byte must be written for change to take effect. Write SBR[15:13] only in special modes.

The value in SBR[12:0] determines the clock rate of the MI Bus. The desired baud rate is determined by the following formula:

$$\text{MI BUS Clock Rate} = \frac{\text{MCLK}}{16 \times \text{BR}}$$

BR is the value written to bits SBR[12:0] to establish baud rate.

**NOTE:** *The baud rate generator is disabled until TE or RE bit in SC0CR2 register is set for the first time after reset, and/or the baud rate generator is disabled when SBR[12:0] = 0.*

BTST — Reserved for test function

BSPL — Reserved for test function

BRLD — Reserved for test function

Bit 7	6	5	4	3	2	1	Bit 0
—	WOMS	—	—	—	—	—	PT
RESET: 0	0	0	0	0	0	0	0

**SC0CR1** — MI Bus Control Register 1

**\$00C2**

Read or write anytime.

**WOMS** — Wired-Or Mode for Serial Pins

This bit controls the two pins (TxD0 and RxD0) associated with the SC0 section.

0 = Pins operate in a normal mode with both high and low drive capability.

1 = Each pin operates in an open drain fashion if that pin is declared as an output.

PT — MI Bus TxD0 polarity

If parity is enabled, this bit determines even or odd parity for both the receiver and the transmitter.

0 = MI Bus transmit pin functions normally.

1 = MI Bus transmit pin will send inverted data.

	Bit 7	6	5	4	3	2	1	Bit 0
	—	—	RIE	—	TE	RE	—	SBK
RESET:	0	0	0	0	0	0	0	0

**SC0CR2** — MI Bus Control Register 2

**\$00C3**

Read or write anytime.

RIE — Receiver Interrupt Enable

0 = RDRF interrupt disabled.

1 = MI Bus interrupt will be requested whenever the RDRF status flag is set.

OR does not generate an interrupt request in MI Bus mode.

TE — Transmitter Enable

0 = Transmitter disabled.

1 = MI Bus transmit logic is enabled and the TxD0 pin (Port S bit 1) is dedicated to the transmitter.

RE — Receiver Enable

0 = Receiver disabled.

1 = Port pin dedicated to the MI Bus; the receiver is enabled by a pull sync and is inhibited during a push field.

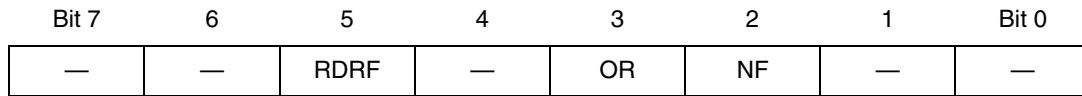
SBK — Send Break

0 = No action.

1 = MI transmit line is set low for 20 time slots.

When an MI Bus wire is held low for eight or more time slots an internal circuit on any slave device connected to the bus may reset or preset the device with default values.





RESET:      1      1      0      0      0      0      0      0

**SC0SR1** — MI Bus Status Register 1

**\$00C4**

The bits in these registers are set by various conditions in the MI Bus hardware and are automatically cleared by special acknowledge sequences. The receive related flag bits in SC0SR1 (RDRF, OR and NF) are all cleared by a read of this register followed by a read of the transmit/receive data register low byte. However, only those bits which were set when SC0SR1 was read will be cleared by the subsequent read of the transmit/receive data register low byte.

Read anytime (used in auto clearing mechanism). Write has no meaning or effect.

**RDRF** — Receive Data Register Full Flag

0 = Contents of the receiver shift register have not been transferred to the receiver data register.

1 = Contents of the receiver serial shift register have been transferred to the receiver data register.

The EOF (end-of-frame) during an MI Bus pull-field is a continuous square wave, which will result in multiple RDRFs. This may be dealt with in any of the following ways:

- By clearing the RIE mask, ignoring unneeded RDRFs, initiating a push field, waiting for TDRE<sup>(1)</sup> and then clearing the RDRF
- By clearing the RE bit when a pull field is complete, followed by setting the RE bit after the TDRE<sup>1</sup> flag associated with the next push field is asserted.
- By disabling the MI Bus.

1. Note that TDRE and TC will both behave in the same way as during normal SCI transmissions. The MI Bus will still be receiving when the TC bit becomes set, hence any queued transmission will not start until the current pull field has finished. See also [Register Descriptions](#).

## OR — Bit Error Flag

0 = No bit error has been detected.

1 = A bit error has been detected.

This bit is set when a push field bit value on the MI Bus does not match the bit value that was sent. This is known as an MI Bus bit error. OR does not generate an interrupt request in MI Bus mode.

## NF — Noise Error Flag

0 = No noise detected.

1 = Noise detected.

This bit is set when noise is detected on the receive line during an MI Bus pull field.

	Bit 7	6	5	4	3	2	1	Bit 0
	SCSWAI	MIE	MDL1	MDL0	0	0	0	RAF
RESET:	0	0	0	0	0	0	0	0

**SC0SR2** — MI Bus Status Register 2

**\$00C5**

Read anytime. Write has no meaning or effect.

## SCSWAI — Serial Communications Interface Stop in WAIT Mode

0 = SCI clock operates normally.

1 = Halt SCI clock generation when in WAIT mode.

## MIE — Motorola Interface Bus (MI Bus) Enable

0 = The SCI functions normally.

1 = MI Bus is enabled for this subsystem.

When MIE is set, the SCI0 registers, bits and pins assume the functionality required for MI Bus.

## MDL1, MDL0 — MI Bus delay select

These bits are used to set up the delay for the start of the NRZ receive for MI Bus operation as shown (for a 20kHz bit rate) in the following table.

**Table 16-1. MI Bus Delay**

MDL1	MDL0	Delay factor	Delay time <sup>(1)</sup>
0	0	1	1.5625 $\mu$ s <sup>(2)</sup>
0	1	2	3.125 $\mu$ s
1	0	3	4.6875 $\mu$ s
1	1	4	6.25 $\mu$ s

1. 20kHz bit rate requires 25 $\mu$ s (40kHz) time slots.  
 2. 25 $\mu$ s  $\div$  16

**RAF — Receiver Active Flag**

0 = A character is not being received

1 = A character is being received

	Bit 7	6	5	4	3	2	1	Bit 0
	R7/T7	R6/T6	R5/T5	R4/T4	R3/T3	R2/T2	R1/T1	R0/T0
Pull field	0	1	0	1	S1	S2	S3	1
Push field	A2	A1	A0	D4	D3	D2	D1	D0
RESET:	—	—	—	—	—	—	—	—

**SC0DRL**— MI Bus Data Register Low

**\$00C7**

This register forms the 8-bit data/address word for the MI push field and contains the 3-bit data word received as the MI pull field.

**R7T7–R0T0 — Receive/Transmit Data Bits 7 to 0**

**READ:** Reads access the three bits of pull field data (stored in bits 3–1) of the read-only MI Bus receive data register. Bits [7:4, 0] are a fixed data pattern when a valid status and end-of-frame is returned. A valid status is represented by the following data pattern: 0101 xxx1 (bits 7–0), where ‘xxx’ is the status. All ones in the receive data register indicate that an error occurred on the MI Bus. Bits are received LSB first by the MCU, and the status bits map as shown in the above table.

**WRITE:** Writes access the eight bits of the write-only MI Bus transmit data register. MI Bus devices require a 5-bit data pattern followed by a 3-bit address pattern to be sent during the push field. The data pattern is mapped to the lowest five bits of the data register and the address to the highest three bits, as shown in the above table. Thus MI-data[4:0] is written to SC0DRL[4:0] and MI-address[2:0] is written to SC0DRL[7:5].

## Section 17. MSCAN Controller

### 17.1 Contents

17.2	Introduction . . . . .	277
17.3	External Pins . . . . .	278
17.4	Message Storage . . . . .	279
17.5	Identifier Acceptance Filter . . . . .	284
17.6	Interrupts . . . . .	287
17.7	Protocol Violation Protection . . . . .	289
17.8	Low Power Modes . . . . .	290
17.9	Timer Link . . . . .	294
17.10	Clock System . . . . .	295
17.11	Memory Map . . . . .	298
17.12	Programmer's Model of Message Storage . . . . .	298
17.13	Programmer's Model of Control Registers . . . . .	303

### 17.2 Introduction

The msCAN12 is the specific implementation of the Motorola scalable CAN (msCAN) concept targeted for the Motorola M68HC12 microcontroller family.

The module is a communication controller implementing the CAN 2.0 A/B protocol as defined in the BOSCH specification dated September 1991.

The CAN protocol was primarily, but not only, designed to be used as a vehicle serial data bus, meeting the specific requirements of this field:

real-time processing, reliable operation in the EMI environment of a vehicle, cost-effectiveness and required bandwidth.

msCAN12 utilises an advanced buffer arrangement resulting in a predictable real-time behaviour and simplifies the application software.

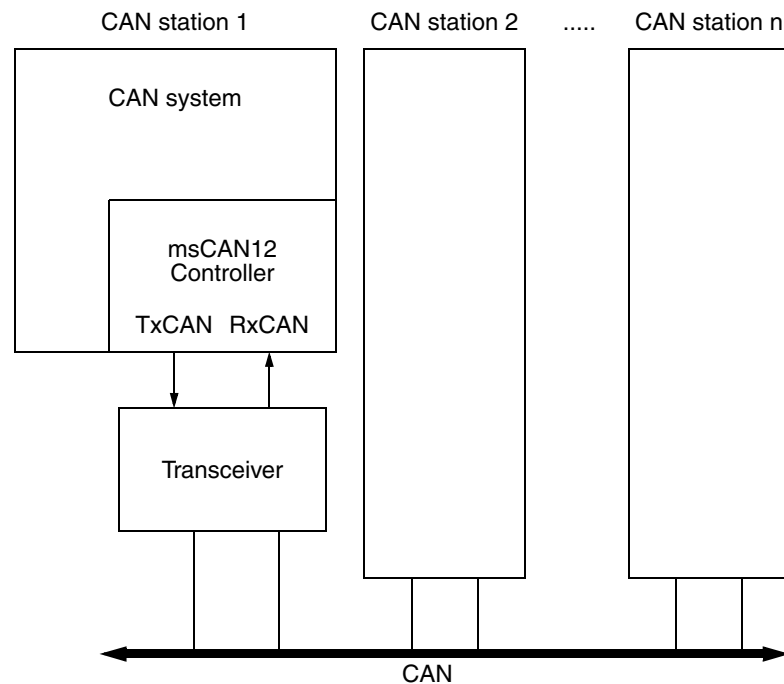
### 17.3 External Pins

The msCAN12 uses 2 external pins, 1 input (RxCAN) and 1 output (TxCAN). The TxCAN output pin represents the logic level on the CAN: 0 is for a dominant state, and 1 is for a recessive state.

RxCAN is on bit 0 of Port CAN, TxCAN is on bit 1. The remaining six pins of Port CAN (112TQFP version only) are controlled by registers in the msCAN12 address space (see [msCAN12 Port CAN Control Register \(PCTLCAN\)](#) and [msCAN12 Port CAN Data Direction Register \(DDRCAN\)](#)).

A typical CAN system with msCAN12 is shown in [Figure 17-1](#).

Each CAN station is connected physically to the CAN bus lines through a transceiver chip. The transceiver is capable of driving the large current needed for the CAN and has current protection, against defective CAN or defective stations.



**Figure 17-1. The CAN System**

## 17.4 Message Storage

msCAN12 facilitates a sophisticated message storage system which addresses the requirements of a broad range of network applications.

### 17.4.1 Background

Modern application layer software is built upon two fundamental assumptions:

1. Any CAN node is able to send out a stream of scheduled messages without releasing the bus between two messages. Such nodes will arbitrate for the bus right after sending the previous message and will only release the bus when arbitration is lost.
2. The internal message queue within any CAN node is organized such that if more than one message is ready to be sent, the highest priority message will be sent out first.

The above behaviour cannot be achieved with a single transmit buffer. That buffer must be reloaded right after the previous message has been sent. This loading process lasts a definite amount of time and has to be completed within the inter-frame sequence (IFS) in order to be able to send an uninterrupted stream of messages. Even if this is feasible for limited CAN bus speeds it requires that the CPU reacts with short latencies to the transmit interrupt.

A double buffer scheme would de-couple the re-loading of the transmit buffers from the actual message sending and as such reduces the reactivity requirements on the CPU. Problems may arise if the sending of a message would be finished just while the CPU re-loads the second buffer, no buffer would then be ready for transmission and the bus would be released.

At least three transmit buffers are required to meet the first of above requirements under all circumstances. The msCAN12 has three transmit buffers.

The second requirement calls for some sort of internal prioritisation which the msCAN12 implements with the local priority concept described below.

### 17.4.2 Receive Structures

The received messages are stored in a two stage input FIFO. The two message buffers are alternately mapped into a single memory area (see [Figure 17-2](#)). While the background receive buffer (RxBG) is exclusively associated to the msCAN12, the foreground receive buffer (RxFG) is addressable by the CPU12. This scheme simplifies the handler software as only one address area is applicable for the receive process.

Both buffers have a size of 13 bytes to store the CAN control bits, the identifier (standard or extended) and the data contents (for details see [Programmer's Model of Message Storage](#)).

The receiver full flag (RXF) in the msCAN12 receiver flag register (CRFLG) (see [msCAN12 Receiver Flag Register \(CRFLG\)](#)) signals the status of the foreground receive buffer. When the buffer contains a correctly received message with matching identifier this flag is set.

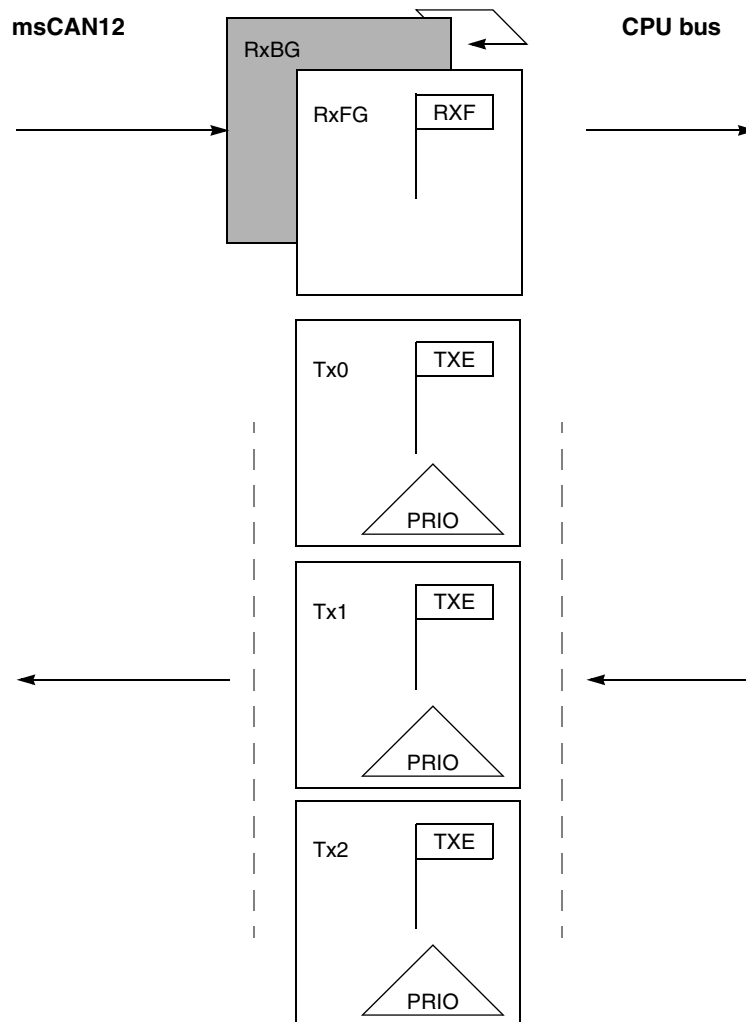


On reception, each message is checked to see if it passes the filter (for details see [Identifier Acceptance Filter](#)) and in parallel is written into RxBG. The msCAN12 copies the content of RxBG into RxFG<sup>(1)</sup>, sets the RXF flag, and generates a receive interrupt to the CPU<sup>(2)</sup>. The user's receive handler has to read the received message from RxFG and then reset the RXF flag in order to acknowledge the interrupt and to release the foreground buffer. A new message, which can follow immediately after the IFS field of the CAN frame, is received into RxBG. The overwriting of the background buffer is independent of the identifier filter function.

---

1. Only if the RXF flag is not set.

2. The receive interrupt is generated only if not masked. A polling scheme can be applied on RXF also.



**Figure 17-2. User Model for Message Buffer Organization**

When the msCAN12 module is transmitting, the msCAN12 receives its own messages into the background receive buffer, RxBG, but does NOT overwrite RxFG, generate a receive interrupt or acknowledge its own messages on the CAN bus. The exception to this rule is in loop-back mode (see [msCAN12 Module Control Register 1 \(CMCR1\)](#).) where the msCAN12 treats its own messages exactly like all other incoming messages. The msCAN12 receives its own transmitted messages in the event that it loses arbitration. If arbitration is lost, the msCAN12 must be prepared to become receiver.

An overrun condition occurs when both the foreground and the background receive message buffers are filled with correctly received messages with accepted identifiers and another message is correctly received from the bus with an accepted identifier. The latter message is discarded and an error interrupt with overrun indication is generated if enabled. The msCAN12 is still able to transmit messages with both receive message buffers filled, but all incoming messages are discarded.

### 17.4.3 Transmit Structures

The msCAN12 has a triple transmit buffer scheme in order to allow multiple messages to be set up in advance and to achieve an optimized real-time performance. The three buffers are arranged as shown in [Figure 17-2](#).

All three buffers have a 13 byte data structure similar to the outline of the receive buffers (see [Programmer's Model of Message Storage](#)). An additional transmit buffer priority register (TBPR) contains an 8-bit so called local priority field (PRIO) (see [Transmit Buffer Priority Registers \(TBPR\)](#)).

In order to transmit a message, the CPU12 has to identify an available transmit buffer which is indicated by a set transmit buffer empty (TXE) flag in the msCAN12 transmitter flag register (CTFLG) (see [msCAN12 Transmitter Flag Register \(CTFLG\)](#)).

The CPU12 then stores the identifier, the control bits and the data content into one of the transmit buffers. Finally, the buffer has to be flagged as being ready for transmission by clearing the TXE flag.

The msCAN12 will then schedule the message for transmission and will signal the successful transmission of the buffer by setting the TXE flag. A transmit interrupt will be emitted<sup>(1)</sup> when TXE is set and this can be used to drive the application software to re-load the buffer.

---

1. The transmit interrupt is generated only if not masked. A polling scheme can be applied on TXE also.

If more than one buffer is scheduled for transmission when the CAN bus becomes available for arbitration, the msCAN12 uses the local priority setting of the three buffers for prioritisation. For this purpose every transmit buffer has an 8-bit local priority field (PRIO). The application software sets this field when the message is set up. The local priority reflects the priority of this particular message relative to the set of messages being emitted from this node. The lowest binary value of the PRIO field is defined to be the highest priority.

The internal scheduling process takes place whenever the msCAN12 arbitrates for the bus. This is also the case after the occurrence of a transmission error.

When a high priority message is scheduled by the application software it may become necessary to abort a lower priority message being set up in one of the three transmit buffers. As messages that are already under transmission cannot be aborted, the user has to request the abort by setting the corresponding abort request flag (ABTRQ) in the transmission control register (CTCR). The msCAN12 grants the request, if possible, by setting the corresponding abort request acknowledge (ABTAK) and the TXE flag in order to release the buffer and by generating a transmit interrupt. The transmit interrupt handler software can tell from the setting of the ABTAK flag whether the message was aborted (ABTAK=1) or sent in the meantime (ABTAK=0).

### 17.5 Identifier Acceptance Filter

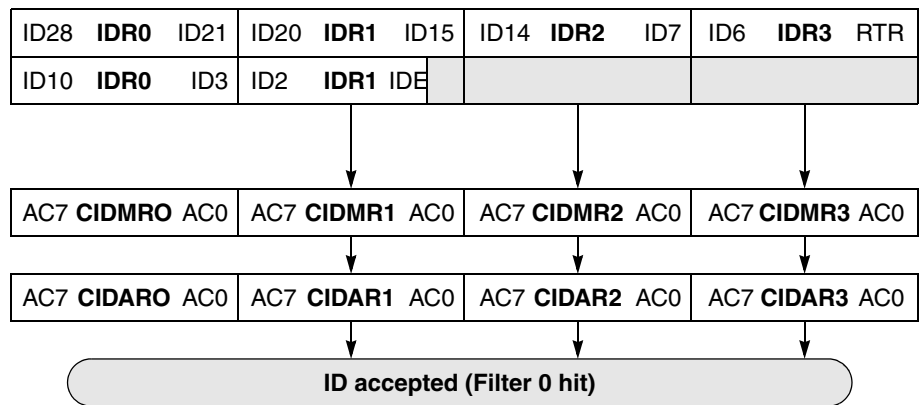
The identifier acceptance registers (CIDAR0–7) define the acceptable patterns of the standard or extended identifier (ID10–ID0 or ID28–ID0). Any of these bits can be marked don't care in the identifier mask registers (CIDMR0–7).

A filter hit is indicated to the application software by a set RXF (receive buffer full flag, see [msCAN12 Receiver Flag Register \(CRFLG\)](#)) and three bits in the identifier acceptance control register (see [msCAN12 Identifier Acceptance Control Register \(CIDAC\)](#)). These identifier hit flags (IDHIT2–0) clearly identify the filter section that caused the acceptance. They simplify the application software's task to identify the

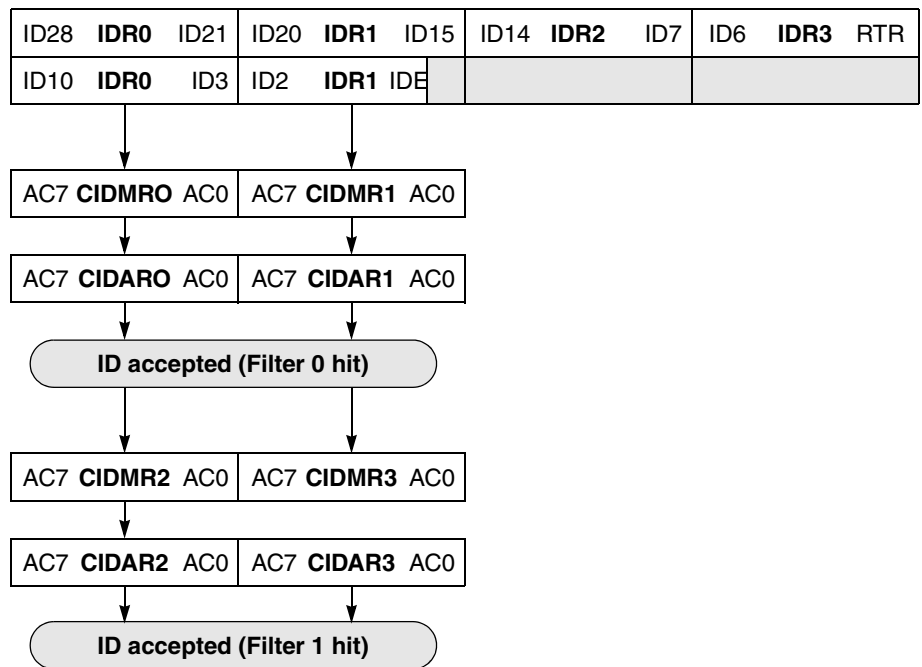
cause of the receiver interrupt. When more than one hit occurs (two or more filters match) the lower hit has priority.

A very flexible programmable generic identifier acceptance filter has been introduced in order to reduce the CPU interrupt loading. The filter is programmable to operate in four different modes:

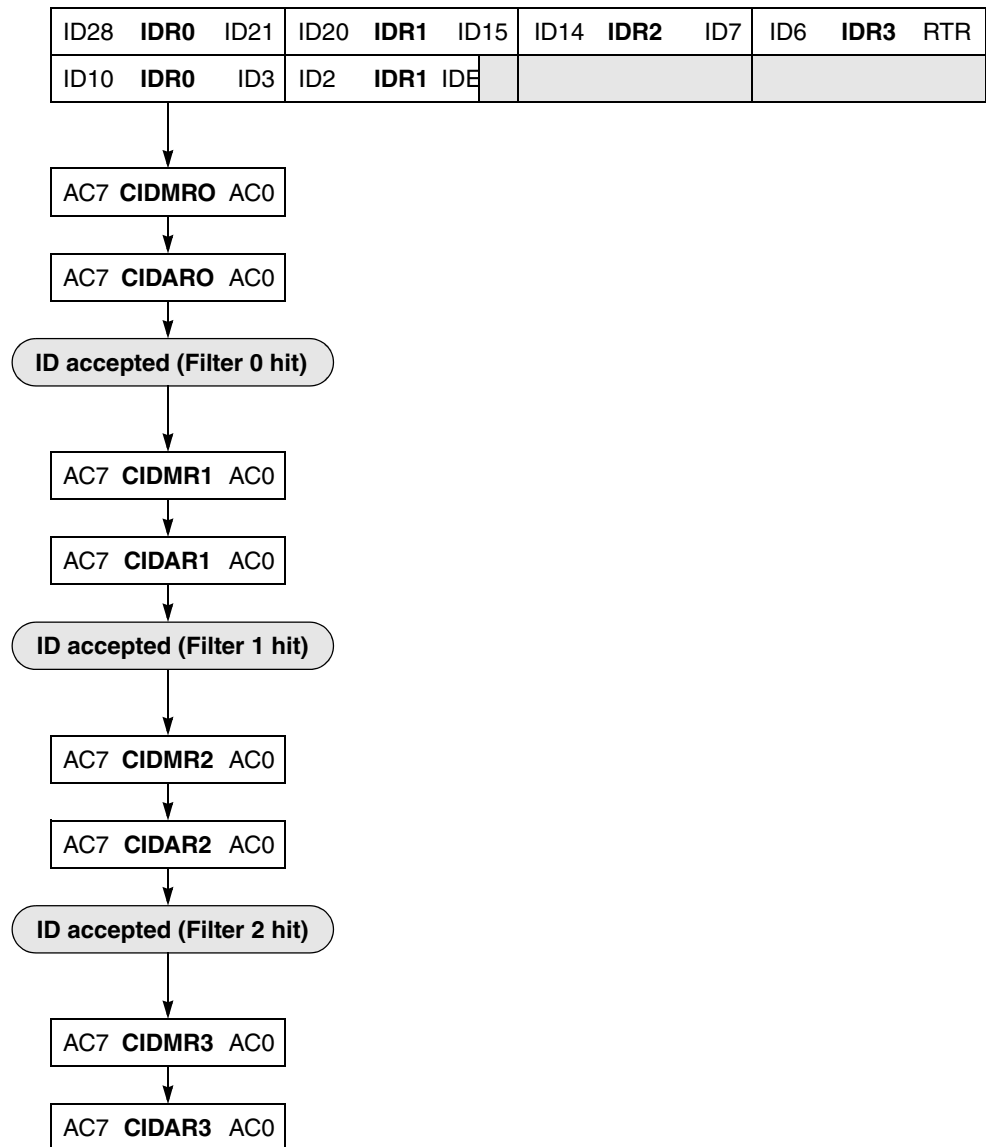
- Two identifier acceptance filters, each to be applied to a) the full 29 bits of the extended identifier and to the following bits of the CAN frame: RTR, IDE, SRR or b) the 11 bits of the standard identifier, the RTR and IDE bits of CAN 2.0A/B messages. This mode implements two filters for a full length CAN 2.0B compliant extended identifier. [Figure 17-3](#) shows how the first 32-bit filter bank (CIDAR0–3, CIDMR0–3) produces a filter 0 hit. Similarly, the second filter bank (CIDAR4–7, CIDMR4–7) produces a filter 1 hit.
- Four identifier acceptance filters, each to be applied to a) the 14 most significant bits of the extended identifier plus the SRR and IDE bits of CAN 2.0B messages or b) the 11 bits of the standard identifier, the RTR and IDE bits of CAN 2.0A/B messages. [Figure 17-4](#) shows how the first 32-bit filter bank (CIDAR0–3, CIDMR0–3) produces filter 0 and 1 hits. Similarly, the second filter bank (CIDAR4–7, CIDMR4–7) produces filter 2 and 3 hits.
- Eight identifier acceptance filters, each to be applied to the first 8 bits of the identifier. This mode implements eight independent filters for the first 8 bits of a CAN 2.0A/B compliant standard identifier or of a CAN 2.0B compliant extended identifier. [Figure 17-5](#) shows how the first 32-bit filter bank (CIDAR0–3, CIDMR0–3) produces filter 0 to 3 hits. Similarly, the second filter bank (CIDAR4–7, CIDMR4–7) produces filter 4 to 7 hits.
- Closed filter. No CAN message will be copied into the foreground buffer RxFG, and the RXF flag will never be set.



**Figure 17-3. 32-bit Maskable Identifier Acceptance Filters**



**Figure 17-4. 16-bit Maskable Acceptance Filters**



**Figure 17-5. 8-bit Maskable Acceptance Filters**

## 17.6 Interrupts

The msCAN12 supports four interrupt vectors mapped onto eleven different interrupt sources, any of which can be individually masked (for details see [msCAN12 Receiver Flag Register \(CRFLG\)](#) to [msCAN12 Transmitter Control Register \(CTCR\)](#)):

- *Transmit interrupt:* At least one of the three transmit buffers is empty (not scheduled) and can be loaded to schedule a message for transmission. The TXE flags of the empty message buffers are set.
- *Receive interrupt:* A message has been successfully received and loaded into the foreground receive buffer. This interrupt is generated immediately after receiving the EOF symbol. The RXF flag is set.
- *Wake-up interrupt:* An activity on the CAN bus occurred during msCAN12 internal SLEEP mode.
- *Error interrupt:* An overrun, error or warning condition occurred. The receiver flag register (CRFLG) indicates one of the following conditions:
  - *Overrun:* an overrun condition as described in [Receive Structures](#) has occurred.
  - *Receiver warning:* the receive error counter has reached the CPU warning limit of 96.
  - *Transmitter warning:* the transmit error counter has reached the CPU warning limit of 96.
  - *Receiver error passive:* the receive error counter has exceeded the error passive limit of 127 and msCAN12 has gone to error passive state.
  - *Transmitter error passive:* the transmit error counter has exceeded the error passive limit of 127 and msCAN12 has gone to error passive state.
  - *Bus off:* the transmit error counter has exceeded 255 and msCAN12 has gone to BUSOFF state.

### 17.6.1 Interrupt Acknowledge

Interrupts are directly associated with one or more status flags in either the msCAN12 receiver flag register (CRFLG) or the msCAN12 transmitter flag register (CTFLG). Interrupts are pending as long as one of the corresponding flags is set. The flags in above registers must be



reset within the interrupt handler in order to handshake the interrupt. The flags are reset through writing a 1 to the corresponding bit position. A flag cannot be cleared if the respective condition still prevails.

**NOTE:** *Bit manipulation instructions (BSET) shall not be used to clear interrupt flags.*

## 17.6.2 Interrupt Vectors

The msCAN12 supports four interrupt vectors as shown in [Table 17-1](#). The vector addresses and the relative interrupt priority are dependent on the chip integration and to be defined.

**Table 17-1. msCAN12 Interrupt Vectors**

Function	Source	Local Mask	Global Mask
Wake-Up	WUPIF	WUPIE	I Bit
Error Interrupts	RWRNIF	RWRNIE	
	TWRNIF	TWRNIE	
	RERRIF	RERRIE	
	TERRIF	TERRIE	
	BOFFIF	BOFFIE	
	OVRIF	OVRIE	
Receive	RXF	RXFIE	
Transmit	TXE0	TXEIE0	
	TXE1	TXEIE1	
	TXE2	TXEIE2	

## 17.7 Protocol Violation Protection

The msCAN12 will protect the user from accidentally violating the CAN protocol through programming errors. The protection logic implements the following features:

- The receive and transmit error counters cannot be written or otherwise manipulated.

- All registers which control the configuration of the msCAN12 cannot be modified while the msCAN12 is on-line. The SFTRES bit in CMCR0 (see [msCAN12 Module Control Register 0 \(CMCR0\)](#)) serves as a lock to protect the following registers:
  - msCAN12 module control register 1 (CMCR1)
  - msCAN12 bus timing register 0 and 1 (CBTR0, CBTR1)
  - msCAN12 identifier acceptance control register (CIDAC)
  - msCAN12 identifier acceptance registers (CIDAR0–7)
  - msCAN12 identifier mask registers (CIDMR0–7)
- The TxCAN pin is forced to recessive when the msCAN12 is in any of the low power modes.

### 17.8 Low Power Modes

In addition to normal mode, the msCAN12 has three modes with reduced power consumption: SLEEP, SOFT\_RESET and POWER\_DOWN mode. In SLEEP and SOFT\_RESET modes, power consumption is reduced by stopping all clocks except those to access the registers. In POWER\_DOWN mode, all clocks are stopped and no power is consumed.

The WAI and STOP instructions put the MCU in low power consumption stand-by modes. [Table 17-2](#) summarizes the combinations of msCAN12 and CPU modes. A particular combination of modes is entered for the given settings of the bits CSWAI, SLPAK, and SFTRES. For all modes, an msCAN wake-up interrupt can occur only if SLPAK=WUPIE=1. While the CPU is in Wait Mode, the msCAN12 can be operated in Normal Mode and generate interrupts (registers can be accessed via background debug mode).

**Table 17-2. msCAN12 vs. CPU operating modes**

msCAN Mode	CPU Mode		
	STOP	WAIT	RUN
POWER_DOWN	CSWAI = X <sup>(1)</sup> SLPAK = X SFTRES = X	CSWAI = 1 SLPAK = X SFTRES = X	
SLEEP		CSWAI = 0 SLPAK = 1 SFTRES = 0	CSWAI = X SLPAK = 1 SFTRES = 0
SOFT_RESET		CSWAI = 0 SLPAK = 0 SFTRES = 1	CSWAI = X SLPAK = 0 SFTRES = 1
Normal		CSWAI = 0 SLPAK = 0 SFTRES = 0	CSWAI = X SLPAK = 0 SFTRES = 0

1. X means don't care.

### 17.8.1 msCAN12 SLEEP Mode

The CPU can request the msCAN12 to enter this low-power mode by asserting the SLPRQ bit in the Module Configuration Register (see [Figure 17-6](#)). The time when the msCAN12 enters Sleep Mode depends on its activity:

- If there are one or more message buffers scheduled for transmission (TXEx = 0), the msCAN will continue to transmit until all transmit message buffers are empty (TXEx = 1, transmitted successfully or aborted) and then goes into Sleep Mode.
- If it is receiving, it continues to receive and goes into Sleep Mode as soon as the CAN bus next becomes idle.
- If it is neither transmitting nor receiving, it immediately goes into Sleep Mode.

**NOTE:** *The application software must avoid setting up a transmission (by clearing one or more TXE flag(s)) and immediately request Sleep Mode (by setting SLPRQ). It then depends on the exact sequence of operations whether the msCAN12 starts transmitting or goes into Sleep Mode directly.*

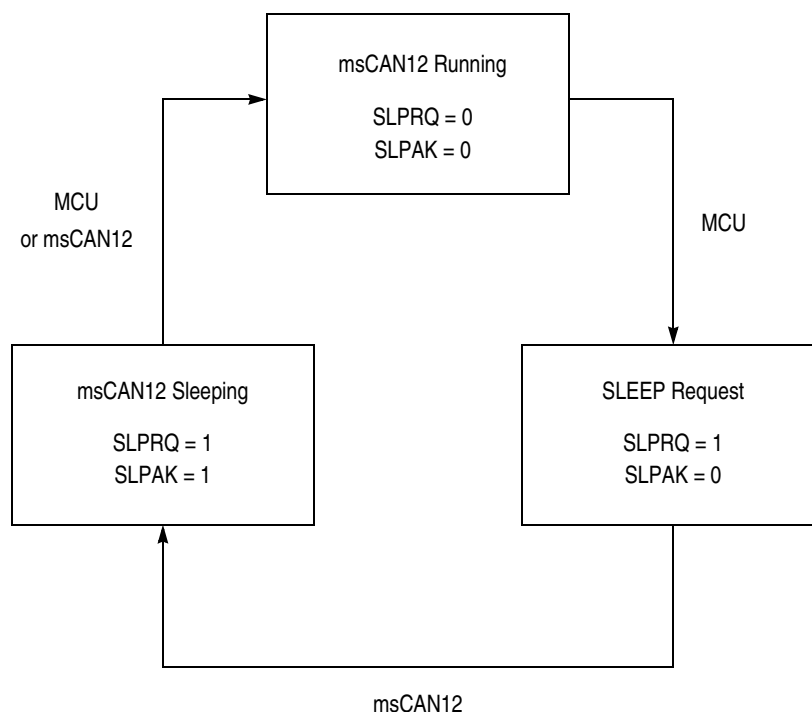
During Sleep Mode, the SLPK flag is set. The application software should use SLPK as a handshake indication for the request (SLPRQ) to go into Sleep Mode. When in Sleep Mode, the msCAN12 stops its internal clocks. However, clocks to allow register accesses still run. If the msCAN12 is in bus-off state, it stops counting the 128\*11 consecutive recessive bits due to the stopped clocks. The TxCAN pin stays in recessive state. If RXF=1, the message can be read and RXF can be cleared. Copying of RxBG into RxFG doesn't take place while in sleep mode. It is possible to access the transmit buffers and to clear the TXE flags. No message abort takes place while in sleep mode.

The msCAN12 leaves Sleep Mode (wake-up) when

- bus activity occurs or
- the MCU clears the SLPRQ bit or
- the MCU sets SFTRES.

**NOTE:** *The MCU cannot clear the SLPRQ bit before the msCAN12 is in Sleep Mode (SLPAK = 1).*

After wake-up, the msCAN12 waits for 11 consecutive recessive bits to synchronize to the bus. As a consequence, if the msCAN12 is woken-up by a CAN frame, this frame is not received. The receive message buffers (RxFG and RxBG) contain messages if they were received before sleep mode was entered. All pending actions are executed upon wake-up: copying of RxBG into RxFG, message aborts and message transmissions. If the msCAN12 is still in bus-off state after sleep mode was left, it continues counting the 128\*11 consecutive recessive bits.



**Figure 17-6. SLEEP Request / Acknowledge Cycle**

### 17.8.2 msCAN12 SOFT\_RESET Mode

In SOFT\_RESET mode, the msCAN12 is stopped. Registers can still be accessed. This mode is used to initialize the module configuration, bit timing, and the CAN message filter. See [msCAN12 Module Control Register 0 \(CMCR0\)](#) for a complete description of the SOFT\_RESET mode.

When setting the SFTRES bit, the msCAN12 immediately stops all ongoing transmissions and receptions, potentially causing the CAN protocol violations.

**NOTE:** *The user is responsible for ensuring that the msCAN12 is not active when SOFT\_RESET mode is entered. The recommended procedure is to bring the msCAN12 into SLEEP mode before the SFTRES bit is set.*

## 17.8.3 msCAN12 POWER\_DOWN Mode

The msCAN12 is in POWER\_DOWN mode when

- the CPU is in STOP mode or
- the CPU is in WAIT mode and the CSWAI bit is set (see [msCAN12 Module Control Register 0 \(CMCR0\)](#)).

When entering the POWER\_DOWN mode, the msCAN12 immediately stops all ongoing transmissions and receptions, potentially causing CAN protocol violations.

**NOTE:** *The user is responsible for ensuring that the msCAN12 is not active when POWER\_DOWN mode is entered. The recommended procedure is to bring the msCAN12 into SLEEP mode before the STOP instruction (or the WAI instruction, if CSWAI is set) is executed.*

To protect the CAN bus system from fatal consequences of violations to the above rule, the msCAN12 drives the TxCAN pin into recessive state.

In POWER\_DOWN mode no registers can be accessed.

## 17.8.4 Programmable Wake-Up Function

The msCAN12 can be programmed to apply a low-pass filter function to the RxCAN input line while in SLEEP mode (see control bit WUPM in the module control register, [msCAN12 Module Control Register 1 \(CMCR1\)](#)). This feature can be used to protect the msCAN12 from wake-up due to short glitches on the CAN bus lines. Such glitches can result from electromagnetic interference within noisy environments.

## 17.9 Timer Link

The msCAN12 generates a timer signal whenever a valid frame has been received. Because the CAN specification defines a frame to be valid if no errors occurred before the EOF field has been transmitted successfully, the timer signal is generated right after the EOF. A pulse of

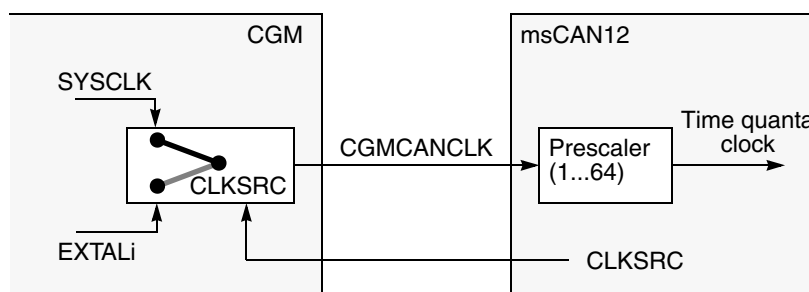
one bit time is generated. As the msCAN12 receiver engine also receives the frames being sent by itself, a timer signal is also generated after a successful transmission.

The previously described timer signal can be routed into the on-chip timer interface module (ECT). This signal is connected to the Timer n Channel m input<sup>(1)</sup> under the control of the timer link enable (TLNKEN) bit in the CMCR0.

After timer n has been programmed to capture rising edge events, it can be used under software control to generate 16-bit time stamps which can be stored with the received message.

## 17.10 Clock System

Figure 17-7 shows the structure of the msCAN12 clock generation circuitry. With this flexible clocking scheme the msCAN12 is able to handle CAN bus rates ranging from 10 kbps up to 1 Mbps.



**Figure 17-7. Clocking Scheme**

The clock source bit (CLKSRC) in the msCAN12 module control register (CMCR1) (see [msCAN12 Bus Timing Register 0 \(CBTR0\)](#)) defines whether the msCAN12 is connected to the output of the crystal oscillator (EXTALi) or to a clock twice as fast as the system clock (ECLK).

The clock source has to be chosen such that the tight oscillator tolerance requirements (up to 0.4%) of the CAN protocol are met. Additionally, for high CAN bus rates (1 Mbps), a 50% duty cycle of the clock is required.

1. The timer channel being used for the timer link is integration dependent.

**NOTE:** *If the system clock is generated from a PLL, it is recommended to select the crystal clock source rather than the system clock source due to jitter considerations, especially at faster CAN bus rates.*

For microcontrollers without the CGM module, CGMCANCLK is driven from the crystal oscillator (EXTALi).

A programmable prescaler is used to generate out of msCANCLK the time quanta (Tq) clock. A time quantum is the atomic unit of time handled by the msCAN12.

$$f_{Tq} = \frac{f_{CGMCANCLK}}{\text{Presc value}}$$

A bit time is subdivided into three segments<sup>(1)</sup>:

- SYNC\_SEG: This segment has a fixed length of one time quantum. Signal edges are expected to happen within this section.
- Time segment 1: This segment includes the PROP\_SEG and the PHASE\_SEG1 of the CAN standard. It can be programmed by setting the parameter TSEG1 to consist of 4 to 16 time quanta.
- Time segment 2: This segment represents the PHASE\_SEG2 of the CAN standard. It can be programmed by setting the TSEG2 parameter to be 2 to 8 time quanta long.

$$\text{BitRate} = \frac{f_{Tq}}{\text{number of TimeQuanta}}$$

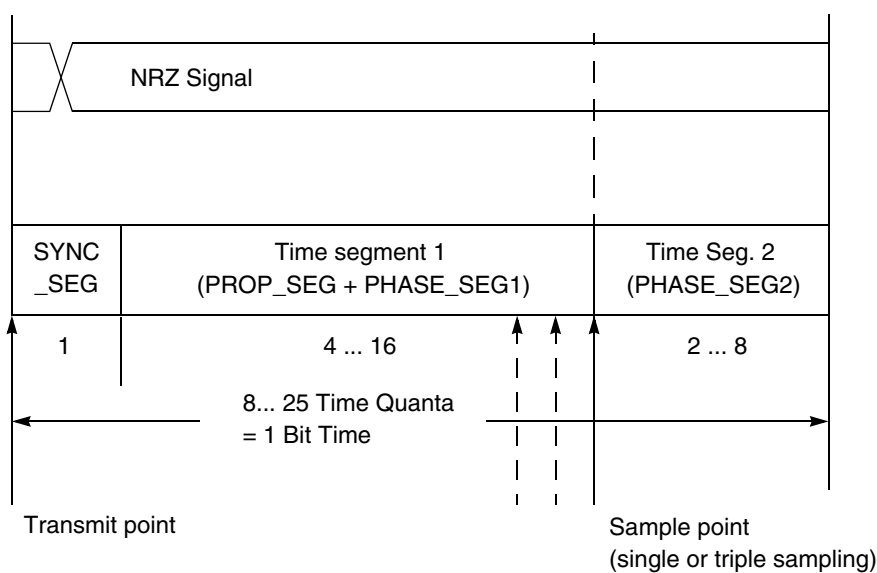
The synchronisation jump width can be programmed in a range of 1 to 4 time quanta by setting the SJW parameter.

Above parameters can be set by programming the bus timing registers (CBTR0–1, see [msCAN12 Bus Timing Register 0 \(CBTR0\)](#) and [msCAN12 Bus Timing Register 1 \(CBTR1\)](#)).

**NOTE:** *It is the user's responsibility to make sure that his bit time settings are in compliance with the CAN standard. [Table 17-3](#) gives an overview on the CAN conforming segment settings and the related parameter values.*

1. For further explanation of the under-lying concepts please refer to ISO/DIS 11519-1, Section 10.3.





**Figure 17-8. Segments within the Bit Time**

**Table 17-3. CAN Standard Compliant Bit Time Segment Settings**

Time Segment 1	TSEG1	Time Segment 2	TSEG2	Synchron. Jump Width	SJW
5 .. 10	4 .. 9	2	1	1 .. 2	0 .. 1
4 .. 11	3 .. 10	3	2	1 .. 3	0 .. 2
5 .. 12	4 .. 11	4	3	1 .. 4	0 .. 3
6 .. 13	5 .. 12	5	4	1 .. 4	0 .. 3
7 .. 14	6 .. 13	6	5	1 .. 4	0 .. 3
8 .. 15	7 .. 14	7	6	1 .. 4	0 .. 3
9 .. 16	8 .. 15	8	7	1 .. 4	0 .. 3

## 17.11 Memory Map

The msCAN12 occupies 128 bytes in the CPU12 memory space. The background receive buffer can only be read in test mode.

**Figure 17-9. msCAN12 Memory Map**

\$0100	Control registers
\$0108	9 bytes
\$0109	Reserved
\$010D	5 bytes
\$010E	Error counters
\$010F	2 bytes
\$0110	Identifier filter
\$011F	16 bytes
\$0120	Reserved
\$013C	29 bytes
\$013D	Port CAN registers
\$013F	3 bytes
\$0140	Receive buffer
\$014F	
\$0150	Transmit buffer 0
\$015F	
\$0160	Transmit buffer 1
\$016F	
\$0170	Transmit buffer 2
\$017F	

## 17.12 Programmer's Model of Message Storage

The following section details the organisation of the receive and transmit message buffers and the associated control registers. For reasons of programmer interface simplification the receive and transmit message buffers have the same outline. Each message buffer allocates 16 bytes in the memory map containing a 13 byte data structure. An additional transmit buffer priority register (TBPR) is defined for the transmit buffers.

**Figure 17-10. Message Buffer Organization**

Address <sup>(1)</sup>	Register name
01x0	Identifier register 0
01x1	Identifier register 1
01x2	Identifier register 2
01x3	Identifier register 3
01x4	Data segment register 0
01x5	Data segment register 1
01x6	Data segment register 2
01x7	Data segment register 3
01x8	Data segment register 4
01x9	Data segment register 5
01xA	Data segment register 6
01xB	Data segment register 7
01xC	Data length register
01xD	Transmit buffer priority register <sup>(2)</sup>
01xE	Unused
01xF	Unused

1. x is 4, 5, 6, or 7 depending on which buffer RxFG, Tx0, Tx1, or Tx2 respectively.

2. Not applicable for receive buffers

### 17.12.1 Message Buffer Outline

Figure 17-11 shows the common 13 byte data structure of receive and transmit buffers for extended identifiers. The mapping of standard identifiers into the IDR registers is shown in Figure 17-12. All bits of the 13 byte data structure are undefined out of reset.

**NOTE:** *The foreground receive buffer can be read anytime but cannot be written.  
 The transmit buffers can be read or written anytime.*

**Figure 17-11. Receive/Transmit Message Buffer Extended Identifier**

ADDR <sup>(1)</sup>	REGISTER	R/W	BIT 7	6	5	4	3	2	1	BIT 0
\$01x0	IDR0	R	ID28	ID27	ID26	ID25	ID24	ID23	ID22	ID21
		W								
\$01x1	IDR1	R	ID20	ID19	ID18	SRR (1)	IDE (1)	ID17	ID16	ID15
		W								
\$01x2	IDR2	R	ID14	ID13	ID12	ID11	ID10	ID9	ID8	ID7
		W								
\$01x3	IDR3	R	ID6	ID5	ID4	ID3	ID2	ID1	ID0	RTR
		W								
\$01x4	DSR0	R	DB7	DB6	DB5	DB4	DB3	DB2	DB1	DB0
		W								
\$01x5	DSR1	R	DB7	DB6	DB5	DB4	DB3	DB2	DB1	DB0
		W								
\$01x6	DSR2	R	DB7	DB6	DB5	DB4	DB3	DB2	DB1	DB0
		W								
\$01x7	DSR3	R	DB7	DB6	DB5	DB4	DB3	DB2	DB1	DB0
		W								
\$01x8	DSR4	R	DB7	DB6	DB5	DB4	DB3	DB2	DB1	DB0
		W								
\$01x9	DSR5	R	DB7	DB6	DB5	DB4	DB3	DB2	DB1	DB0
		W								
\$01xA	DSR6	R	DB7	DB6	DB5	DB4	DB3	DB2	DB1	DB0
		W								
\$01xB	DSR7	R	DB7	DB6	DB5	DB4	DB3	DB2	DB1	DB0
		W								
\$01xC	DLR	R					DLC3	DLC2	DLC1	DLC0
		W								

1. x is 4, 5, 6, or 7 depending on which buffer RxFG, Tx0, Tx1, or Tx2 respectively.

**Figure 17-12. Standard Identifier Mapping**

ADDR <sup>(1)</sup>	REGISTER	R/W	BIT 7	6	5	4	3	2	1	BIT 0
\$01x0	IDR0	R	ID10	ID9	ID8	ID7	ID6	ID5	ID4	ID3
		W								
\$01x1	IDR1	R	ID2	ID1	ID0	RTR	IDE(0)			
		W								
\$01x2	IDR2	R								
		W								
\$01x3	IDR3	R								
		W								

1. x is 4, 5, 6, or 7 depending on which buffer RxFG, Tx0, Tx1, or Tx2 respectively.

## 17.12.2 Identifier Registers (IDRn)

The identifiers consist of either 11 bits (ID10–ID0) for the standard, or 29 bits (ID28–ID0) for the extended format. ID10/28 is the most significant bit and is transmitted first on the bus during the arbitration procedure. The priority of an identifier is defined to be highest for the smallest binary number.

### SRR — Substitute Remote Request

This fixed recessive bit is used only in extended format. It must be set to 1 by the user for transmission buffers and will be stored as received on the CAN bus for receive buffers.

### IDE — ID Extended

This flag indicates whether the extended or standard identifier format is applied in this buffer. In the case of a receive buffer the flag is set as being received and indicates to the CPU how to process the buffer identifier registers. In the case of a transmit buffer the flag indicates to the msCAN12 what type of identifier to send.

0 = Standard format (11-bit)

1 = Extended format (29-bit)

## RTR — Remote transmission request

This flag reflects the status of the Remote Transmission Request bit in the CAN frame. In the case of a receive buffer it indicates the status of the received frame and supports the transmission of an answering frame in software. In the case of a transmit buffer this flag defines the setting of the RTR bit to be sent.

0 = Data frame

1 = Remote frame

### 17.12.3 Data Length Register (DLR)

This register keeps the data length field of the CAN frame.

#### DLC3 – DLC0 — Data length code bits

The data length code contains the number of bytes (data byte count) of the respective message. At the transmission of a remote frame, the data length code is transmitted as programmed while the number of transmitted data bytes is always 0. The data byte count ranges from 0 to 8 for a data frame. [Table 17-4](#) shows the effect of setting the DLC bits.

**Table 17-4. Data length codes**

Data length code				Data byte count
DLC3	DLC2	DLC1	DLC0	
0	0	0	0	0
0	0	0	1	1
0	0	1	0	2
0	0	1	1	3
0	1	0	0	4
0	1	0	1	5
0	1	1	0	6
0	1	1	1	7
1	0	0	0	8

### 17.12.4 Data Segment Registers (DSRn)

The eight data segment registers contain the data to be transmitted or being received. The number of bytes to be transmitted or being received is determined by the data length code in the corresponding DLR.

### 17.12.5 Transmit Buffer Priority Registers (TBPR)

		BIT 7	BIT 6	BIT 5	BIT 4	BIT 3	BIT 2	BIT 1	BIT 0
TBPR <sup>(1)</sup> \$01xD	R	PRI07	PRI06	PRI05	PRI04	PRI03	PRI02	PRI01	PRI00
	W								
RESET		–	–	–	–	–	–	–	–

1. x is 5, 6, or 7 depending on which buffer Tx0, Tx1, or Tx2 respectively.

#### PRI07 – PRI00 — Local Priority

This field defines the local priority of the associated message buffer. The local priority is used for the internal prioritisation process of the msCAN12 and is defined to be highest for the smallest binary number. The msCAN12 implements the following internal prioritisation mechanism:

- All transmission buffers with a cleared TXE flag participate in the prioritisation immediately before the SOF (Start of Frame) is sent.
- The transmission buffer with the lowest local priority field wins the prioritisation.
- In cases of more than one buffer having the same lowest priority, the message buffer with the lower index number wins.

## 17.13 Programmer's Model of Control Registers

### 17.13.1 Overview

The programmer's model has been laid out for maximum simplicity and efficiency.

## 17.13.2 msCAN12 Module Control Register 0 (CMCR0)

	Bit 7	6	5	4	3	2	1	Bit 0	
CMCR0	R	0	0	CSWAI	SYNCH	TLNKEN	SLPAK	SLPRQ	SFTRES
\$0100	W								
RESET		0	0	1	0	0	0	0	1

### CSWAI — CAN Stops in Wait Mode

- 0 = The module is not affected during WAIT mode.
- 1 = The module ceases to be clocked during WAIT mode.

### SYNCH — Synchronized Status

- This bit indicates whether the msCAN12 is synchronized to the CAN bus and as such can participate in the communication process.
- 0 = msCAN12 is not synchronized to the CAN bus
  - 1 = msCAN12 is synchronized to the CAN bus

### TLNKEN — Timer Enable

- This flag is used to establish a link between the msCAN12 and the on-chip timer (see [Timer Link](#)).
- 0 = The port is connected to the timer input.
  - 1 = The msCAN12 timer signal output is connected to the timer input.

### SLPAK — SLEEP Mode Acknowledge

- This flag indicates whether the msCAN12 is in module internal SLEEP Mode. It shall be used as a handshake for the SLEEP Mode request (see [msCAN12 SLEEP Mode](#)).
- 0 = Wake-up – The msCAN12 is not in SLEEP Mode.
  - 1 = SLEEP – The msCAN12 is in SLEEP Mode.

### SLPRQ — SLEEP request

- This flag allows to request the msCAN12 to go into an internal power-saving mode (see [msCAN12 SLEEP Mode](#)).
- 0 = Wake-up – The msCAN12 will function normally.
  - 1 = SLEEP request – The msCAN12 will go into SLEEP Mode when the CAN bus is idle, i.e. the module is not receiving a message and all transmit buffers are empty.



### SFTRES— SOFT\_RESET

When this bit is set by the CPU, the msCAN12 immediately enters the SOFT\_RESET state. Any ongoing transmission or reception is aborted and synchronisation to the bus is lost.

The following registers will go into and stay in the same state as out of hard reset: CMCR0, CRFLG, CRIER, CTFLG, CTCR.

The registers CMCR1, CBTR0, CBTR1, CIDAC, CIDAR0–3, CIDMR0–3 can only be written by the CPU when the msCAN12 is in SOFT\_RESET state. The values of the error counters are not affected by SOFT\_RESET.

When this bit is cleared by the CPU, the msCAN12 will try to synchronize to the CAN bus: If the msCAN12 is not in BUSOFF state it will be synchronized after 11 recessive bits on the bus; if the msCAN12 is in BUSOFF state it continues to wait for 128 occurrences of 11 recessive bits.

Clearing SFTRES and writing to other bits in CMCR0 must be in separate instructions.

- 0 = Normal operation
- 1 = msCAN12 in SOFT\_RESET state.

### 17.13.3 msCAN12 Module Control Register 1 (CMCR1).

	Bit 7	6	5	4	3	2	1	Bit 0
CMCR1	R	0	0	0	0	LOOPB	WUPM	CLKSRC
\$0101	W							
RESET		0	0	0	0	0	0	0

#### LOOPB — Loop Back Self Test Mode

When this bit is set the msCAN12 performs an internal loop back which can be used for self test operation: the bit stream output of the transmitter is fed back to the receiver internally. The RxCAN input pin is ignored and the TxCAN output goes to the recessive state (1). The msCAN12 behaves as it does normally when transmitting and treats its own transmitted message as a message received from a remote

node. In this state the msCAN12 ignores the bit sent during the ACK slot of the CAN frame acknowledge field to insure proper reception of its own message. Both transmit and receive interrupts are generated.

0 = Normal operation

1 = Activate loop back self test mode

### WUPM — Wake-Up Mode

This flag defines whether the integrated low-pass filter is applied to protect the msCAN12 from spurious wake-ups (see [Programmable Wake-Up Function](#)).

0 = msCAN12 will wake up the CPU after any recessive to dominant edge on the CAN bus.

1 = msCAN12 will wake up the CPU only in the case of dominant pulse on the bus which has a length of at least approximately  $T_{wup}$ .

### CLKSRC — msCAN12 Clock Source

This flag defines which clock source the msCAN12 module is driven from (only for system with CGM module; see [Clock System, Figure 17-7](#)).

0 = The msCAN12 clock source is EXTALi.

1 = The msCAN12 clock source is SYSCLK, twice the frequency of ECLK.

**NOTE:** *The CMCR1 register can be written only if the SFTRES bit in CMCR0 is set.*

### 17.13.4 msCAN12 Bus Timing Register 0 (CBTR0)

		Bit 7	6	5	4	3	2	1	Bit 0
CBTR0	R	SJW1	SJW0	BRP5	BRP4	BRP3	BRP2	BRP1	BRP0
\$0102	W								
RESET		0	0	0	0	0	0	0	0

#### SJW1, SJW0 — Synchronization Jump Width

The synchronization jump width defines the maximum number of time quanta ( $T_q$ ) clock cycles by which a bit may be shortened, or lengthened, to achieve resynchronization on data transitions on the bus (see [Table 17-5](#)).

**Table 17-5. Synchronization jump width**

SJW1	SJW0	Synchronization jump width
0	0	1 $T_q$ clock cycle
0	1	2 $T_q$ clock cycles
1	0	3 $T_q$ clock cycles
1	1	4 $T_q$ clock cycles

#### BRP5 – BRP0 — Baud Rate Prescaler

These bits determine the time quanta ( $T_q$ ) clock, which is used to build up the individual bit timing, according to [Table 17-6](#).

**Table 17-6. Baud rate prescaler**

BRP5	BRP4	BRP3	BRP2	BRP1	BRP0	Prescaler value (P)
0	0	0	0	0	0	1
0	0	0	0	0	1	2
0	0	0	0	1	0	3
0	0	0	0	1	1	4
:	:	:	:	:	:	:
:	:	:	:	:	:	:
1	1	1	1	1	1	64

**NOTE:** The CBTR0 register can only be written if the SFTRES bit in CMCR0 is set.

## 17.13.5 msCAN12 Bus Timing Register 1 (CBTR1).

		Bit 7	6	5	4	3	2	1	Bit 0
CBTR1	R	SAMP	TSEG22	TSEG21	TSEG20	TSEG13	TSEG12	TSEG11	TSEG10
\$0103	W								
RESET		0	0	0	0	0	0	0	0

### SAMP — Sampling

This bit determines the number of samples of the serial bus to be taken per bit time. If set three samples per bit are taken, the regular one (sample point) and two preceding samples, using a majority rule. For higher bit rates SAMP should be cleared, which means that only one sample will be taken per bit.

0 = One sample per bit.

1 = Three samples per bit.<sup>(1)</sup>

### TSEG22 – TSEG10 — Time Segment

Time segments within the bit time fix the number of clock cycles per bit time, and the location of the sample point. (See [Figure 17-8](#))

**Table 17-7. Time segment syntax**

SYNC_SEG	System expects transitions to occur on the bus during this period.
Transmit point	A node in transmit mode will transfer a new value to the CAN bus at this point.
Sample point	A node in receive mode will sample the bus at this point. If the three samples per bit option is selected then this point marks the position of the third sample.

Time segment 1 (TSEG1) and time segment 2 (TSEG2) are programmable as shown in [Table 17-8](#).

1. In this case, PHASE\_SEG1 must be at least two time quanta.

**Table 17-8. Time segment values**

TSEG13	TSEG12	TSEG11	TSEG10	Time segment 1	TSEG22	TSEG21	TSEG20	Time segment 2
0	0	0	0	1 Tq clock cycle	0	0	0	1 Tq clock cycle
0	0	0	1	2 Tq clock cycles	0	0	1	2 Tq clock cycles
0	0	1	0	3 Tq clock cycles	.	.	.	.
0	0	1	1	4 Tq clock cycles	.	.	.	.
.	.	.	.	.	1	1	1	8 Tq clock cycles
.	.	.	.	.				
1	1	1	1	16 Tq clock cycles				

The bit time is determined by the oscillator frequency, the baud rate prescaler, and the number of time quanta (Tq) clock cycles per bit (as shown above).

$$\text{BitTime} = \frac{\text{Presc value}}{f_{\text{CGMCANCLK}}} \bullet \text{number of TimeQuanta}$$

**NOTE:** The CBTR1 register can only be written if the SFTRES bit in CMCR0 is set

### 17.13.6 msCAN12 Receiver Flag Register (CRFLG)

All bits of this register are read and clear only. A flag can be cleared by writing a 1 to the corresponding bit position. A flag can only be cleared when the condition which caused the setting is no more valid. Writing a 0 has no effect on the flag setting. Every flag has an associated interrupt enable flag in the CRIER register. A hard or soft reset clears the register.

		Bit 7	6	5	4	3	2	1	Bit 0
CRFLG \$0104	R	WUPIF	RWRNIF	TWRNIF	RERRIF	TERRIF	BOFFIF	OVRIF	RXF
	W								
RESET		0	0	0	0	0	0	0	0

#### WUPIF — Wake-up Interrupt Flag

If the msCAN12 detects bus activity while in SLEEP Mode, it sets the WUPIF flag. If not masked, a Wake-Up interrupt is pending while this flag is set.

- 0 = No wake-up activity has been observed while in SLEEP Mode.
- 1 = msCAN12 has detected activity on the bus and requested wake-up.

## RWRNIF — Receiver Warning Interrupt Flag

This flag is set when the msCAN12 goes into warning status due to the Receive Error counter (REC) exceeding 96 and neither one of the Error interrupt flags or the Bus-Off interrupt flag is set<sup>(1)</sup>. If not masked, an Error interrupt is pending while this flag is set.

0 = No receiver warning status has been reached.

1 = msCAN12 went into receiver warning status.

## TWRNIF — Transmitter Warning Interrupt Flag

This bit will be set when the msCAN12 goes into warning status due to the Transmit Error counter (TEC) exceeding 96 and neither one of the Error interrupt flags or the Bus-Off interrupt flag is set<sup>(2)</sup>. If not masked, an Error interrupt is pending while this flag is set.

0 = No transmitter warning status has been reached.

1 = msCAN12 went into transmitter warning status.

## RERRIF — Receiver Error Passive Interrupt Flag

This flag is set when the msCAN12 goes into error passive status due to the Receive Error counter (REC) exceeding 127 and the Bus-Off interrupt flag is not set<sup>(3)</sup>. If not masked, an Error interrupt is pending while this flag is set.

0 = No receiver error passive status has been reached.

1 = msCAN12 went into receiver error passive status.

## TERRIF — Transmitter Error Passive Interrupt Flag

This flag is set when the msCAN12 goes into error passive status due to the Transmit Error counter (TEC) exceeding 127 and the Bus-Off interrupt flag is not set<sup>(4)</sup>. If not masked, an Error interrupt is pending while this flag is set.

0 = No transmitter error passive status has been reached.

1 = msCAN12 went into transmitter error passive status.

1. Condition to set the flag:  $RWRNIF = (96 \leq REC \leq 127) \& \overline{RERRIF} \& \overline{TERRIF} \& \overline{BOFFIF}$

2. Condition to set the flag:  $TWRNIF = (96 \leq TEC \leq 127) \& \overline{RERRIF} \& \overline{TERRIF} \& \overline{BOFFIF}$

3. Condition to set the flag:  $RERRIF = (128 \leq REC \leq 255) \& \overline{BOFFIF}$

4. Condition to set the flag:  $TERRIF = (128 \leq TEC \leq 255) \& \overline{BOFFIF}$

### BOFFIF — BUSOFF Interrupt Flag

This flag is set when the msCAN12 goes into BUSOFF status, due to the Transmit Error counter exceeding 255. It cannot be cleared before the msCAN12 has monitored 128 times 11 consecutive recessive bits on the bus. If not masked, an Error interrupt is pending while this flag is set.

0 = No BUSOFF status has been reached.

1 = msCAN12 went into BUSOFF status.

### OVRIF — Overrun Interrupt Flag

This flag is set when a data overrun condition occurs. If not masked, an Error interrupt is pending while this flag is set.

0 = No data overrun has occurred.

1 = A data overrun has been detected.

### RXF — Receive Buffer Full

The RXF flag is set by the msCAN12 when a new message is available in the foreground receive buffer. This flag indicates whether the buffer is loaded with a correctly received message. After the CPU has read that message from the receive buffer, the RXF flag must be handshaken (cleared) in order to release the buffer. A set RXF flag prohibits the exchange of the background receive buffer into the foreground buffer. If not masked, a Receive interrupt is pending while this flag is set.

0 = The receive buffer is released (not full).

1 = The receive buffer is full. A new message is available.

**WARNING:** *To ensure data integrity, no registers of the receive buffer shall be read while the RXF flag is cleared.*

**NOTE:** *The CRFLG register is held in the reset state when the SFTRES bit in CMCR0 is set.*

## 17.13.7 msCAN12 Receiver Interrupt Enable Register (CRIER)

	Bit 7	6	5	4	3	2	1	Bit 0	
CRIER	R	WUPIE	RWRNIE	TWRNIE	RERRIE	TERRIE	BOFFIE	OVRIE	RXFIE
\$0105	W								
RESET		0	0	0	0	0	0	0	0

**WUPIE** — Wake-up Interrupt Enable

0 = No interrupt is generated from this event.

1 = A wake-up event results in a wake-up interrupt.

**RWRNIE** — Receiver Warning Interrupt Enable

0 = No interrupt is generated from this event.

1 = A receiver warning status event results in an error interrupt.

**TWRNIE** — Transmitter Warning Interrupt Enable

0 = No interrupt is generated from this event.

1 = A transmitter warning status event results in an error interrupt.

**RERRIE** — Receiver Error Passive Interrupt Enable

0 = No interrupt is generated from this event.

1 = A receiver error passive status event results in an error interrupt.

**TERRIE** — Transmitter Error Passive Interrupt Enable

0 = No interrupt is generated from this event.

1 = A transmitter error passive status event results in an error interrupt.

**BOFFIE** — BUSOFF Interrupt Enable

0 = No interrupt is generated from this event.

1 = A BUSOFF event results in an error interrupt.

**OVRIE** — Overrun Interrupt Enable

0 = No interrupt is generated from this event.

1 = An overrun event results in an error interrupt.



RXFIE — Receiver Full Interrupt Enable

0 = No interrupt is generated from this event.

1 = A receive buffer full (successful message reception) event results in a receive interrupt.

**NOTE:** The CRIER register is held in the reset state when the SFTRES bit in CMCR0 is set.

### 17.13.8 msCAN12 Transmitter Flag Register (CTFLG)

The Abort Acknowledge flags are read only. The Transmitter Buffer Empty flags are read and clear only. A flag can be cleared by writing a 1 to the corresponding bit position. Writing a zero has no effect on the flag setting. The Transmitter Buffer Empty flags each have an associated interrupt enable bit in the CTCR register. A hard or soft reset resets the register.

		Bit 7	6	5	4	3	2	1	Bit 0
CTFLG	R	0	ABTAK2	ABTAK1	ABTAK0	0	TXE2	TXE1	TXE0
\$0106	W								
RESET		0	0	0	0	0	1	1	1

#### ABTAK2 – ABTAK0 — Abort Acknowledge

This flag acknowledges that a message has been aborted due to a pending abort request from the CPU. After a particular message buffer has been flagged empty, this flag can be used by the application software to identify whether the message has been aborted successfully or has been sent in the meantime. The ABTAKx flag is cleared implicitly whenever the corresponding TXE flag is cleared.

0 = The message has not been aborted, thus has been sent out.

1 = The message has been aborted.

#### TXE2 – TXE0 — Transmitter Buffer Empty

This flag indicates that the associated transmit message buffer is empty, thus not scheduled for transmission. The CPU must handshake (clear) the flag after a message has been set up in the transmit buffer and is due for transmission. The msCAN12 sets the flag after the message has been

sent successfully. The flag is also set by the msCAN12 when the transmission request was successfully aborted due to a pending abort request ([msCAN12 Transmitter Control Register \(CTCR\)](#)). If not masked, a transmit interrupt is pending while this flag is set.

Clearing a TXEx flag also clears the corresponding ABTAKx flag (see above). When a TXEx flag is set, the corresponding ABTRQx bit is cleared (see [msCAN12 Transmitter Control Register \(CTCR\)](#)).

0 = The associated message buffer is full (loaded with a message due for transmission).

1 = The associated message buffer is empty (not scheduled).

**WARNING:** *To ensure data integrity, no registers of the transmit buffers should be written to while the associated TXE flag is cleared.*

**NOTE:** *The CTFLG register is held in the reset state if the SFTRES bit CMCR0 is set.*

## 17.13.9 msCAN12 Transmitter Control Register (CTCR)

		Bit 7	6	5	4	3	2	1	Bit 0
CTCR	R	0	ABTRQ2	ABTRQ1	ABTRQ0	0	TXEIE2	TXEIE1	TXEIE0
\$0107	W								
RESET		0	0	0	0	0	0	0	0

### ABTRQ2 – ABTRQ0 — Abort Request

The CPU sets an ABTRQx bit to request that a scheduled message buffer (TXEx = 0) shall be aborted. The msCAN12 grants the request if the message has not already started transmission, or if the transmission is not successful (lost arbitration or error). When a message is aborted the associated TXE and the Abort Acknowledge flag (ABTAK, see [msCAN12 Transmitter Flag Register \(CTFLG\)](#)) are set and an TXE interrupt is generated if enabled. The CPU cannot reset ABTRQx. ABTRQx is cleared implicitly whenever the associated TXE flag is set.

0 = No abort request.

1 = Abort request pending.

**NOTE:** The software must not clear one or more of the TXE flags in CTFGL and simultaneously set the respective ABTRQ bit(s).

TXEIE2 – TXEIE0 — Transmitter Empty Interrupt Enable

0 = No interrupt will be generated from this event.

1 = A transmitter empty (transmit buffer available for transmission) event will result in a transmitter empty interrupt.

**NOTE:** The CTCR register is held in the reset state when the SFTRES bit in CMCR0 is set.

### 17.13.10 msCAN12 Identifier Acceptance Control Register (CIDAC)

		Bit 7	6	5	4	3	2	1	Bit 0
CIDAC	R	0	0	IDAM1	IDAM0	0	IDHIT2	IDHIT1	IDHIT0
\$0108	W								
RESET		0	0	0	0	0	0	0	0

IDAM1 – IDAM0 — Identifier Acceptance Mode

The CPU sets these flags to define the identifier acceptance filter organisation (see [Identifier Acceptance Filter](#)). [Table 17-8](#) summarizes the different settings. In Filter Closed mode no messages are accepted such that the foreground buffer is never reloaded.

**Table 17-9. Identifier Acceptance Mode Settings**

IDAM1	IDAM0	Identifier Acceptance Mode
0	0	Two 32 bit Acceptance Filters
0	1	Four 16 bit Acceptance Filters
1	0	Eight 8 bit Acceptance Filters
1	1	Filter Closed

## IDHIT2 – IDHIT0 — Identifier Acceptance Hit Indicator

The msCAN12 sets these flags to indicate an identifier acceptance hit (see [Identifier Acceptance Filter](#)). [Table 17-8](#) summarizes the different settings.

**Table 17-10l. dentifier Acceptance Hit Indication**

IDHIT2	IDHIT1	IDHIT0	Identifier Acceptance Hit
0	0	0	Filter 0 Hit
0	0	1	Filter 1 Hit
0	1	0	Filter 2 Hit
0	1	1	Filter 3 Hit
1	0	0	Filter 4 Hit
1	0	1	Filter 5 Hit
1	1	0	Filter 6 Hit
1	1	1	Filter 7 Hit

The IDHIT indicators are always related to the message in the foreground buffer. When a message gets copied from the background to the foreground buffer the indicators are updated as well.

**NOTE:** *The CIDAC register can only be written if the SFTRES bit in CMCR0 is set.*

### 17.13.11 msCAN12 Receive Error Counter (CRXERR)

		Bit 7	6	5	4	3	2	1	Bit 0
CRXERR	R	RXERR7	RXERR6	RXERR5	RXERR4	RXERR3	RXERR2	RXERR1	RXERR0
\$010E	W								
RESET		0	0	0	0	0	0	0	0

This register reflects the status of the msCAN12 receive error counter. The register is read only.

### 17.13.12 msCAN12 Transmit Error Counter (CTXERR)

		Bit 7	6	5	4	3	2	1	Bit 0
CTXERR	R	TXERR7	TXERR6	TXERR5	TXERR4	TXERR3	TXERR2	TXERR1	TXERR0
\$010F	W								
RESET		0	0	0	0	0	0	0	0

This register reflects the status of the msCAN12 transmit error counter. The register is read only.

**NOTE:** Both error counters must only be read when in SLEEP or SOFT\_RESET mode.

### 17.13.13 msCAN12 Identifier Acceptance Registers (CIDAR0–7)

On reception each message is written into the background receive buffer. The CPU is only signalled to read the message however, if it passes the criteria in the identifier acceptance and identifier mask registers (accepted); otherwise, the message is overwritten by the next message (dropped).

The acceptance registers of the msCAN12 are applied on the IDR0 to IDR3 registers of incoming messages in a bit by bit manner.

For extended identifiers all four acceptance and mask registers are applied. For standard identifiers only the first two (CIDMR0/1 and CIDAR0/1) are applied.

		Bit 7	6	5	4	3	2	1	Bit 0
CIDAR0 \$0110	R	AC7	AC6	AC5	AC4	AC3	AC2	AC1	AC0
	W								
CIDAR1 \$0111	R	AC7	AC6	AC5	AC4	AC3	AC2	AC1	AC0
	W								
CIDAR2 \$0112	R	AC7	AC6	AC5	AC4	AC3	AC2	AC1	AC0
	W								
CIDAR3 \$0113	R	AC7	AC6	AC5	AC4	AC3	AC2	AC1	AC0
	W								

RESET      -            -            -            -            -            -            -            -

		Bit 7	6	5	4	3	2	1	Bit 0
CIDAR4 \$0118	R	AC7	AC6	AC5	AC4	AC3	AC2	AC1	AC0
	W								
CIDAR5 \$0119	R	AC7	AC6	AC5	AC4	AC3	AC2	AC1	AC0
	W								
CIDAR6 \$011A	R	AC7	AC6	AC5	AC4	AC3	AC2	AC1	AC0
	W								
CIDAR7 \$011B	R	AC7	AC6	AC5	AC4	AC3	AC2	AC1	AC0
	W								

RESET      -            -            -            -            -            -            -            -

### AC7 – AC0 — Acceptance Code Bits

AC7 – AC0 comprise a user defined sequence of bits with which the corresponding bits of the related identifier register (IDRn) of the receive message buffer are compared. The result of this comparison is then masked with the corresponding identifier mask register.

**NOTE:** *The CIDAR0–7 registers can only be written if the SFTRES bit in CMCR0 is set.*

### 17.13.14 msCAN12 Identifier Mask Registers (CIDMR0–7)

The identifier mask register specifies which of the corresponding bits in the identifier acceptance register are relevant for acceptance filtering. To receive standard identifiers in 32 bit filter mode it is required to program the last three bits (AM2–AM0) in the mask registers CIDMR1 and CIDMR5 to 'don't care'. To receive standard identifiers in 16 bit filter mode it is required to program the last three bits (AM2–AM0) in the mask registers CIDMR1, CIDMR3, CIDMR5 and CIDMR7 to 'don't care'.

		Bit 7	6	5	4	3	2	1	Bit 0
CIDMR0 \$0114	R	AM7	AM6	AM5	AM4	AM3	AM2	AM1	AM0
	W								
CIDMR1 \$0115	R	AM7	AM6	AM5	AM4	AM3	AM2	AM1	AM0
	W								
CIDMR2 \$0116	R	AM7	AM6	AM5	AM4	AM3	AM2	AM1	AM0
	W								
CIDMR3 \$0117	R	AM7	AM6	AM5	AM4	AM3	AM2	AM1	AM0
	W								
RESET		-	-	-	-	-	-	-	-

		Bit 7	6	5	4	3	2	1	Bit 0
CIDMR4 \$011C	R	AM7	AM6	AM5	AM4	AM3	AM2	AM1	AM0
	W								
CIDMR5 \$011D	R	AM7	AM6	AM5	AM4	AM3	AM2	AM1	AM0
	W								
CIDMR6 \$011E	R	AM7	AM6	AM5	AM4	AM3	AM2	AM1	AM0
	W								
CIDMR7 \$011F	R	AM7	AM6	AM5	AM4	AM3	AM2	AM1	AM0
	W								
RESET		-	-	-	-	-	-	-	-

## AM7 – AM0 — Acceptance Mask Bits

If a particular bit in this register is cleared this indicates that the corresponding bit in the identifier acceptance register must be the same as its identifier bit, before a match is detected. The message is accepted if all such bits match. If a bit is set, it indicates that the state of the corresponding bit in the identifier acceptance register does not affect whether or not the message is accepted.

Bit description:

0 = Match corresponding acceptance code register and identifier bits.

1 = Ignore corresponding acceptance code register bit.

**NOTE:** The CIDMR0–7 registers can only be written if the SFTRES bit in CMCR0 is set.

### 17.13.15 msCAN12 Port CAN Control Register (PCTLCAN)

		Bit 7	6	5	4	3	2	1	Bit 0
PCTLCAN	R	0	0	0	0	0	0	PUPCAN	RDPCAN
\$013D	W								
RESET		0	0	0	0	0	0	0	0

The following bits control pins 7 through 2 of Port CAN. Pins 1 and 0 are reserved for the RxCan (input only) and TxCan (output only) pins.

#### PUPCAN — Pull-Up Enable Port CAN

0 = Pull mode disabled for Port CAN.

1 = Pull mode enabled for Port CAN.

In 80QFP all PortCAN[2:7] pins should either be defined as outputs or have their pull-ups enabled.

#### RDPCAN — Reduced Drive Port CAN

0 = Reduced drive disabled for Port CAN.

1 = Reduced drive enabled for Port CAN.



## 17.13.16 msCAN12 Port CAN Data Register (PORTCAN)

		Bit 7	6	5	4	3	2	1	Bit 0
PORTCAN	R	PCAN7	PCAN6	PCAN5	PCAN4	PCAN3	PCAN2	TxCAN	RxCAN
\$013E	W								
RESET		0	0	0	0	0	0	0	0

### PCAN7 – PCAN2 — Port CAN Data Bits (not available in 80QFP)

Writing to PCANx stores the bit value in an internal bit memory. This value is driven to the respective pin only if DDCANx = 1.

Reading PCANx returns

- the value of the internal bit memory driven to the pin, if DDCANx = 1
- the value of the respective pin, if DDCANx = 0

Reading bits 1 and 0 returns the value of the TxCAN and RxCAN pins, respectively.

## 17.13.17 msCAN12 Port CAN Data Direction Register (DDRCAN)

DDRCAN register determines the primary direction for the Port CAN pins which are available as general purpose I/O. The value in the DDRCAN also affects the source of data for reads of the corresponding Port CAN register. When the DDCANx = 0 (input), the pin is read. When the DDCANx = 1 (output), the internal bit memory is read.

		Bit 7	6	5	4	3	2	1	Bit 0
DDRCAN	R	DDCAN7	DDCAN6	DDCAN5	DDCAN4	DDCAN3	DDCAN2	0	0
\$013F	W								
RESET		0	0	0	0	0	0	0	0

### DDCAN7 – DDCAN2 — Data Direction Port CAN Bits

0 = Respective I/O pin is configured for input.

1 = Respective I/O pin is configured for output.



## Section 18. Analog-to-Digital Converter

### 18.1 Contents

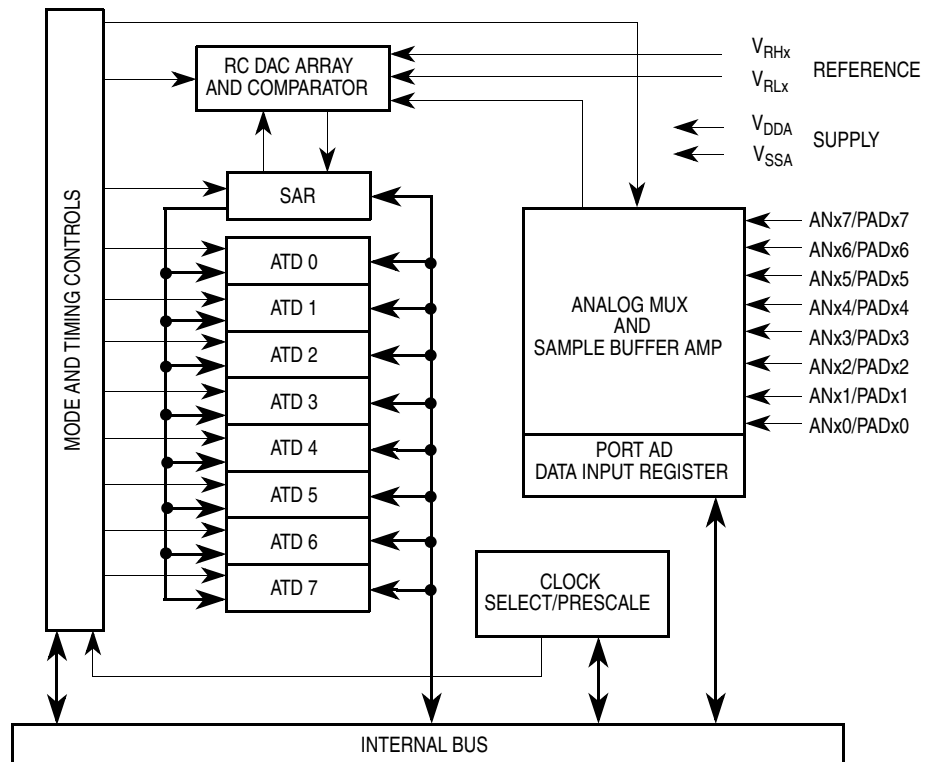
18.2	Introduction . . . . .	323
18.3	Functional Description . . . . .	324
18.4	ATD Registers . . . . .	325
18.5	ATD Mode Operation . . . . .	336

### 18.2 Introduction

The 112TQFP version of the 68HC(9)12D60 has two identical ATD modules identified as ATD0 and ATD1. Except for the  $V_{DDA}$  and  $V_{SSA}$  Analog supply voltage, all pins are duplicated and indexed with '0' or '1' in the following description. An 'x' indicates either '0' or '1'.

The 80QFP version has only one ATD available, ATD0. ATD1 is not bonded out. As this module defaults to disabled on reset and it's I/O are inputs by default it requires no configuration.

The ATD module is an 8-channel, 10-bit or 8-bit, multiplexed-input successive-approximation analog-to-digital converter. It does not require external sample and hold circuits because of the type of charge redistribution technique used. The ATD converter timing can be synchronized to the system P clock. The ATD module consists of a 16-word (32-byte) memory-mapped control register block used for control, testing and configuration.



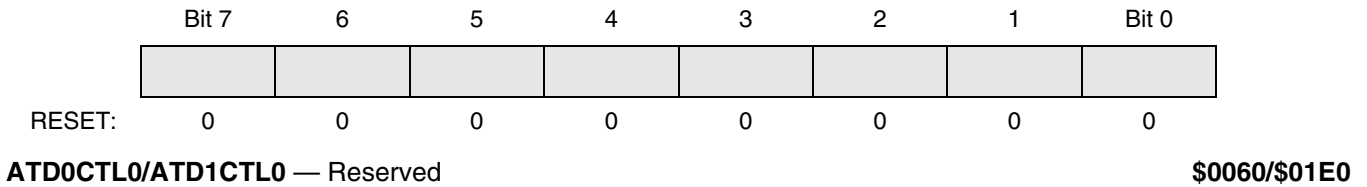
**Figure 18-1. Analog-to-Digital Converter Block Diagram**

## 18.3 Functional Description

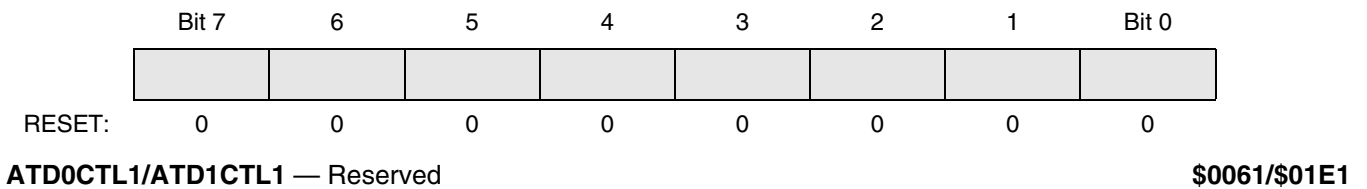
A single conversion sequence consists of four or eight conversions, depending on the state of the select 8 channel mode (S8CM) bit when ATDxCTL5 is written. There are eight basic conversion modes. In the non-scan modes, the SCF bit is set after the sequence of four or eight conversions has been performed and the ATD module halts. In the scan modes, the SCF bit is set after the first sequence of four or eight conversions has been performed, and the ATD module continues to restart the sequence. In both modes, the CCF bit associated with each register is set when that register is loaded with the appropriate conversion result. That flag is cleared automatically when that result register is read. The conversions are started by writing to the control registers.

## 18.4 ATD Registers

Control and data registers for the ATD modules are described below. Both ATDs have identical control registers mapped in two blocks of 16 bytes.



Writes to this register will abort current conversion sequence.  
 READ: any time WRITE: any time.



WRITE: Write to this register has no meaning  
 READ: Special Mode only

	Bit 7	6	5	4	3	2	1	Bit 0
	ADPU	AFFC	AWAI	0	0	0	ASCIE	ASCIF
RESET:	0	0	0	0	0	0	0	0

**ATD0CTL2/ATD1CTL2** — ATD Control Register 2

**\$0062/\$01E2**

The ATD control register 2 and 3 are used to select the power up mode, interrupt control, and freeze control. Writes to these registers abort any current conversion sequence.

Read or write anytime except ASCIF bit, which cannot be written.

Bit positions ATDCTL2[4:2] and ATDCTL3[7:2] are unused and always read as zeros.

#### ADPU — ATD Disable

0 = Disables the ATD, including the analog section for reduction in power consumption.

1 = Allows the ATD to function normally.

Software can disable the clock signal to the A/D converter and power down the analog circuits to reduce power consumption. When reset to zero, the ADPU bit aborts any conversion sequence in progress. Because the bias currents to the analog circuits are turned off, the ATD requires a period of recovery time to stabilize the analog circuits after setting the ADPU bit.

#### AFFC — ATD Fast Flag Clear All

0 = ATD flag clearing operates normally (read the status register before reading the result register to clear the associated CCF bit).

1 = Changes all ATD conversion complete flags to a fast clear sequence. Any access to a result register (ATD0–7) will cause the associated CCF flag to clear automatically if it was set at the time.

#### AWAI — ATD Wait Mode

0 = ATD continues to run when the MCU is in wait mode

1 = ATD stops to save power when the MCU is in wait mode

When the AWAI bit is set and the module enters wait mode, most of the clocks stop and the analog portion powers down. When the module comes out of wait, it is recommended that a stabilisation delay (stop and ATD power up recovery time,  $t_{SR}$ ) is allowed before new conversions are started. Additionally, the ATD does not re-initialise automatically on leaving wait mode.

**ASCIE** — ATD Sequence Complete Interrupt Enable  
 0 = Disables ATD interrupt  
 1 = Enables ATD interrupt on sequence complete

**ASCIF** — ATD Sequence Complete Interrupt Flag  
 Cannot be written in any mode.  
 0 = No ATD interrupt occurred  
 1 = ATD sequence complete

	Bit 7	6	5	4	3	2	1	Bit 0
	0	0	0	0	0	0	FRZ1	FRZ0
RESET:	0	0	0	0	0	0	0	0

**ATD0CTL3/ATD1CTL3** — ATD Control Register 3

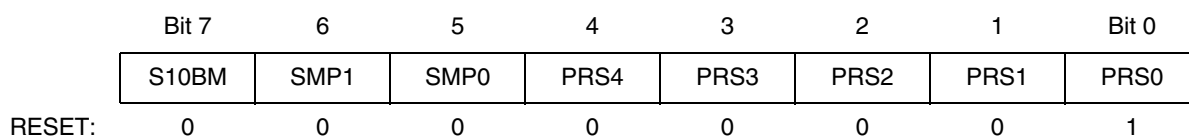
**\$0063/\$01E3**

**FRZ1, FRZ0** — Background Debug (Freeze) Enable (suspend module operation at breakpoint)

When debugging an application, it is useful in many cases to have the ATD pause when a breakpoint is encountered. These two bits determine how the ATD will respond when background debug mode becomes active.

**Table 18-1. ATD Response to Background Debug Enable**

FRZ1	FRZ0	ATD Response
0	0	Continue conversions in active background mode
0	1	Reserved
1	0	Finish current conversion, then freeze
1	1	Freeze when BDM is active



**ATD0CTL4/ATD1CTL4** — ATD Control Register 4

**\$0064/\$01E4**

The ATD control register 4 is used to select the clock source and set up the prescaler. Writes to the ATD control registers initiate a new conversion sequence. If a write occurs while a conversion is in progress, the conversion is aborted and ATD activity halts until a write to ATDxCTL5 occurs.

**S10BM** — 10 bit Mode  
 0 = 8 bit operation  
 1 = 10 bit operation

**SMP1, SMP0** — Select Sample Time

Used to select one of four sample times after the buffered sample and transfer has occurred.

**Table 18-2. Final Sample Time Selection**

SMP1	SMP0	Final Sample Time
0	0	2 A/D clock periods
0	1	4 A/D clock periods
1	0	8 A/D clock periods
1	1	16 A/D clock periods



PRS4, PRS3, PRS2, PRS1, PRS0 — Select Divide-By Factor for ATD P-Clock Prescaler.

The binary value written to these bits (1 to 31) selects the divide-by factor for the modulo counter-based prescaler. The P clock is divided by this value plus one and then fed into a  $\div 2$  circuit to generate the ATD module clock. The divide-by-two circuit insures symmetry of the output clock signal. Clearing these bits causes the prescale value default to one which results in a  $\div 2$  prescale factor. This signal is then fed into the  $\div 2$  logic. The reset state divides the P clock by a total of four and is appropriate for nominal operation at 2 MHz. [Table 18-3](#) shows the divide-by operation and the appropriate range of system clock frequencies.

**Table 18-3. Clock Prescaler Values**

Prescale Value	Total Divisor	Max P Clock <sup>(1)</sup>	Min P Clock <sup>(2)</sup>
00000	$\div 2$	4 MHz	1 MHz
00001	$\div 4$	8 MHz	2 MHz
00010	$\div 6$	8 MHz	3 MHz
00011	$\div 8$	8 MHz	4 MHz
00100	$\div 10$	8 MHz	5 MHz
00101	$\div 12$	8 MHz	6 MHz
00110	$\div 14$	8 MHz	7 MHz
00111	$\div 16$	8 MHz	8 MHz
01xxx	Do Not Use		
1xxxx			

1. Maximum conversion frequency is 2 MHz. Maximum P clock divisor value will become maximum conversion rate that can be used on this ATD module.
2. Minimum conversion frequency is 500 kHz. Minimum P clock divisor value will become minimum conversion rate that this ATD can perform.

	Bit 7	6	5	4	3	2	1	Bit 0
	0	S8CM	SCAN	MULT	CD	CC	CB	CA
RESET:	0	0	0	0	0	0	0	0

**ATD0CTL5/ATD1CTL5** — ATD Control Register 5

**\$0065/\$01E5**

The ATD control register 5 is used to select the conversion modes, the conversion channel(s), and initiate conversions.

Read or write any time. Writes to the ATD control registers initiate a new conversion sequence. If a conversion sequence is in progress when a write occurs, that sequence is aborted and the SCF and CCF bits are reset.

**S8CM** — Select 8 Channel Mode

0 = Conversion sequence consists of four conversions

1 = Conversion sequence consists of eight conversions

**SCAN** — Enable Continuous Channel Scan

0 = Single conversion sequence

1 = Continuous conversion sequences (scan mode)

When a conversion sequence is initiated by a write to the ATDxCTL register, the user has a choice of performing a sequence of four (or eight, depending on the S8CM bit) conversions or continuously performing four (or eight) conversion sequences.

**MULT** — Enable Multichannel Conversion

0 = ATD sequencer runs all four or eight conversions on a **single** input channel selected via the CD, CC, CB, and CA bits.

1 = ATD sequencer runs each of the four or eight conversions on **sequential** channels in a specific group. Refer to [Table 18-4](#).

CD, CC, CB, and CA — Channel Select for Conversion

**Table 18-4. Multichannel Mode Result Register Assignment**

S8CM	CD	CC	CB	CA	Channel Signal	Result in ADRxx if MULT = 1
0	0	0	0	0	AN0	ADRx0
			0	1	AN1	ADRx1
			1	0	AN2	ADRx2
			1	1	AN3	ADRx3
0	0	1	0	0	AN4	ADRx0
			0	1	AN5	ADRx1
			1	0	AN6	ADRx2
			1	1	AN7	ADRx3
0	1	0	0	0	Reserved	ADRx0
			0	1	Reserved	ADRx1
			1	0	Reserved	ADRx2
			1	1	Reserved	ADRx3
0	1	1	0	0	V <sub>RH</sub>	ADRx0
			0	1	V <sub>RL</sub>	ADRx1
			1	0	(V <sub>RH</sub> + V <sub>RL</sub> )/2	ADRx2
			1	1	TEST/Reserved	ADRx3
1	0	0	0	0	AN0	ADRx0
		0	0	1	AN1	ADRx1
		0	1	0	AN2	ADRx2
		0	1	1	AN3	ADRx3
		1	0	0	AN4	ADRx4
		1	0	1	AN5	ADRx5
		1	1	0	AN6	ADRx6
1	1	1	AN7	ADRx7		
1	1	0	0	0	Reserved	ADRx0
		0	0	1	Reserved	ADRx1
		0	1	0	Reserved	ADRx2
		0	1	1	Reserved	ADRx3
		1	0	0	V <sub>RH</sub>	ADRx4
		1	0	1	V <sub>RL</sub>	ADRx5
		1	1	0	(V <sub>RH</sub> + V <sub>RL</sub> )/2	ADRx6
		1	1	1	TEST/Reserved	ADRx7

Shaded bits are “don’t care” if MULT = 1 and the entire block of four or eight channels make up a conversion sequence. When MULT = 0, all four bits (CD, CC, CB, and CA) must be specified and a conversion sequence consists of four or eight consecutive conversions of the single specified channel.

# Analog-to-Digital Converter

**NOTE:** Conversion of  $(VRH-VRL)/2$  returns \$7F, \$80 or \$81 in 8-bit mode.

	Bit 7	6	5	4	3	2	1	Bit 0
	SCF	0	0	0	0	CC2	CC1	CC0
RESET:	0	0	0	0	0	0	0	0

**ATD0STAT0/ATD1STAT0** — ATD Status Register

**\$0066/\$01E6**

	Bit 7	6	5	4	3	2	1	Bit 0
	CCF7	CCF6	CCF5	CCF4	CCF3	CCF2	CCF1	CCF0
RESET:	0	0	0	0	0	0	0	0

**ATD0STAT1/ATD1STAT1** — ATD Status Register

**\$0067/\$01E7**

The ATD status registers contain the flags indicating the completion of ATD conversions.

Normally, it is read-only. In special mode, the SCF bit and the CCF bits may also be written.

## SCF — Sequence Complete Flag

This bit is set at the end of the conversion sequence when in the single conversion sequence mode ( $SCAN = 0$  in  $ATDxCTL5$ ) and is set at the end of the first conversion sequence when in the continuous conversion mode ( $SCAN = 1$  in  $ATDxCTL5$ ). When  $AFFC = 0$ , SCF is cleared when a write is performed to  $ATDxCTL5$  to initiate a new conversion sequence. When  $AFFC = 1$ , SCF is cleared after the first result register is read.

## CC[2:0] — Conversion Counter for Current Sequence of Four or Eight Conversions

This 3-bit value reflects the contents of the conversion counter pointer in a four or eight count sequence. This value also reflects which result register will be written next, indicating which channel is currently being converted.

### CCF[7:0] — Conversion Complete Flags

Each of these bits are associated with an individual ATD result register. For each register, this bit is set at the end of conversion for the associated ATD channel and remains set until that ATD result register is read. It is cleared at that time if AFFC bit is set, regardless of whether a status register read has been performed (i.e., a status register read is not a pre-qualifier for the clearing mechanism when AFFC = 1). Otherwise the status register must be read to clear the flag.

	Bit 7	6	5	4	3	2	1	Bit 0
	SAR9	SAR8	SAR7	SAR6	SAR5	SAR4	SAR3	SAR2
RESET:	0	0	0	0	0	0	0	0

**ATD0TESTH/ATD1TESTH** — ATD Test Register

**\$0068/\$01E8**

	Bit 7	6	5	4	3	2	1	Bit 0
	SAR1	SAR0	RST	TSTOUT	TST3	TST2	TST1	TST0
RESET:	0	0	0	0	0	0	0	0

**ATD0TESTL/ATD1TESTL** — ATD Test Register

**\$0069/\$01E9**

The test registers control various special modes which are used during manufacturing. The test register can be read or written only in the special modes. In the normal modes, reads of the test register return zero and writes have no effect.

### SAR[9:0] — SAR Data

Reads of this byte return the current value in the SAR. Writes to this byte change the SAR to the value written. Bits SAR[9:0] reflect the ten SAR bits used during the resolution process for a 10-bit result.

# Analog-to-Digital Converter

## RST — Module Reset Bit

When set, this bit causes all registers and activity in the module to assume the same state as out of power-on reset (except for ADPU bit in ATDCTL2, which remains set, allowing the ATD module to remain enabled).

## TSTOUT — Multiplex Output of TST[3:0] (Factory Use)

## TST[3:0] — Test Bits 3 to 0 (Reserved)

Selects one of 16 reserved factory testing modes

Bit 7	6	5	4	3	2	1	Bit 0
PADx7	PADx6	PADx5	PADx4	PADx3	PADx2	PADx1	PADx0
RESET: 0	0	0	0	0	0	0	0

**PORTAD0/PORTAD1** — Port AD Data Input Register

**\$006F/\$01EF**

## PADx[7:0] — Port AD Data Input Bits

After reset these bits reflect the state of the input pins.

May be used for general-purpose digital input. When the software reads PORTADx, it obtains the digital levels that appear on the corresponding port AD pins. Pins with signals not meeting  $V_{IL}$  or  $V_{IH}$  specifications will have an indeterminate value. Writes to this register have no meaning at any time.

8-bit mode	Bit 7	Bit 6	Bit 5	Bit 4	Bit 3	Bit 2	Bit 1	Bit 0
10-bit mode	Bit 9	Bit 8	Bit 7	Bit 6	Bit 5	Bit 4	Bit 3	Bit 2

RESET:            u            u            u            u            u            u            u            u

<b>ADR<sub>x</sub>0H</b> — A/D Conversion Result Register High 0	<b>\$0070/\$01F0</b>
<b>ADR<sub>x</sub>1H</b> — A/D Conversion Result Register High 1	<b>\$0072/\$01F2</b>
<b>ADR<sub>x</sub>2H</b> — A/D Conversion Result Register High 2	<b>\$0074/\$01F4</b>
<b>ADR<sub>x</sub>3H</b> — A/D Conversion Result Register High 3	<b>\$0076/\$01F6</b>
<b>ADR<sub>x</sub>4H</b> — A/D Conversion Result Register High 4	<b>\$0078/\$01F8</b>
<b>ADR<sub>x</sub>5H</b> — A/D Conversion Result Register High 5	<b>\$007A/\$01FA</b>
<b>ADR<sub>x</sub>6H</b> — A/D Conversion Result Register High 6	<b>\$007C/\$01FC</b>
<b>ADR<sub>x</sub>7H</b> — A/D Conversion Result Register High 7	<b>\$007E/\$01FE</b>

### ADR<sub>xx</sub>H[7:0] — ATD Conversion result (high)

The reset condition for these registers is undefined.

In 8-bit mode, these registers contain the left-justified, unsigned result from the 8-bit ATD conversion.

In 10-bit mode these registers contain the high order bits of the conversion result.

8-bit mode	—	—	—	—	—	—	—	—
10-bit mode	Bit 1	Bit 0	—	—	—	—	—	—

RESET:            u            u            u            u            u            u            u            u

<b>ADR<sub>x</sub>0L</b> — A/D Conversion Result Register Low 0	<b>\$0071/\$01F1</b>
<b>ADR<sub>x</sub>1L</b> — A/D Conversion Result Register Low 1	<b>\$0073/\$01F3</b>
<b>ADR<sub>x</sub>2L</b> — A/D Conversion Result Register Low 2	<b>\$0075/\$01F5</b>
<b>ADR<sub>x</sub>3L</b> — A/D Conversion Result Register Low 3	<b>\$0077/\$01F7</b>
<b>ADR<sub>x</sub>4L</b> — A/D Conversion Result Register Low 4	<b>\$0079/\$01F9</b>
<b>ADR<sub>x</sub>5L</b> — A/D Conversion Result Register Low 5	<b>\$007B/\$01FB</b>
<b>ADR<sub>x</sub>6L</b> — A/D Conversion Result Register Low 6	<b>\$007D/\$01FD</b>
<b>ADR<sub>x</sub>7L</b> — A/D Conversion Result Register Low 7	<b>\$007F/\$01FF</b>

### ADR<sub>xx</sub>L[7:0] — ATD Conversion result (low)

The reset condition for these registers is undefined.

In 8-bit mode, these registers bits are reserved.

In 10-bit mode these registers contain the remaining two low order bits of the conversion result in bits 6 and 7.

The channel from which this result was obtained is dependent on the conversion mode selected. The registers are always read-only in normal mode.

### 18.5 ATD Mode Operation

**STOP** — causes all clocks to halt (if the S bit in the CCR is zero). The system is placed in a minimum-power standby mode. This aborts any conversion sequence in progress.

**WAIT** — ATD conversion continues unless AWAI bit in ATDxCTL2 register is set.

**BDM** — Debug options available as set in register ATDxCTL3.

**USER** — ATD continues running unless ADPU is cleared.

**ADPU** — ATD operations are stopped if ADPU = 0, but registers are accessible.



## Section 19. Development Support

### 19.1 Contents

19.2	Introduction . . . . .	337
19.3	Instruction Queue . . . . .	337
19.4	Background Debug Mode . . . . .	339
19.5	Breakpoints . . . . .	355
19.6	Instruction Tagging . . . . .	362

### 19.2 Introduction

Development support involves complex interactions between 68HC(9)12D60 resources and external development systems. The following section concerns instruction queue and queue tracking signals, background debug mode, and instruction tagging.

### 19.3 Instruction Queue

The CPU12 instruction queue provides at least three bytes of program information to the CPU when instruction execution begins. The CPU12 always completely finishes executing an instruction before beginning to execute the next instruction. Status signals IPIPE[1:0] provide information about data movement in the queue and indicate when the CPU begins to execute instructions. This makes it possible to monitor CPU activity on a cycle-by-cycle basis for debugging. Information available on the IPIPE[1:0] pins is time multiplexed. External circuitry can latch data movement information on rising edges of the E-clock signal; execution start information can be latched on falling edges. [Table 19-1](#) shows the meaning of data on the pins.

Table 19-11. PIPE Decoding

Data Movement — IPIPE[1:0] Captured at Rising Edge of E Clock <sup>(1)</sup>		
IPIPE[1:0]	Mnemonic	Meaning
0:0	—	No Movement
0:1	LAT	Latch Data From Bus
1:0	ALD	Advance Queue and Load From Bus
1:1	ALL	Advance Queue and Load From Latch
Execution Start — IPIPE[1:0] Captured at Falling Edge of E Clock <sup>(2)</sup>		
IPIPE[1:0]	Mnemonic	Meaning
0:0	—	No Start
0:1	INT	Start Interrupt Sequence
1:0	SEV	Start Even Instruction
1:1	SOD	Start Odd Instruction

1. Refers to data that was on the bus at the previous E falling edge.
2. Refers to bus cycle starting at this E falling edge.

Program information is fetched a few cycles before it is used by the CPU. In order to monitor cycle-by-cycle CPU activity, it is necessary to externally reconstruct what is happening in the instruction queue. Internally the MCU only needs to buffer the data from program fetches. For system debug it is necessary to keep the data and its associated address in the reconstructed instruction queue. The raw signals required for reconstruction of the queue are ADDR, DATA, R/W, ECLK, and status signals IPIPE[1:0].

The instruction queue consists of two 16-bit queue stages and a holding latch on the input of the first stage. To advance the queue means to move the word in the first stage to the second stage and move the word from either the holding latch or the data bus input buffer into the first stage. To start even (or odd) instruction means to execute the opcode in the high-order (or low-order) byte of the second stage of the instruction queue.

## 19.4 Background Debug Mode

Background debug mode (BDM) is used for system development, in-circuit testing, field testing, and programming. BDM is implemented in on-chip hardware and provides a full set of debug options.

Because BDM control logic does not reside in the CPU, BDM hardware commands can be executed while the CPU is operating normally. The control logic generally uses free CPU cycles to execute these commands, but can steal cycles from the CPU when necessary. Other BDM commands are firmware based, and require the CPU to be in active background mode for execution. While BDM is active, the CPU executes a firmware program located in a small on-chip ROM that is available in the standard 64-Kbyte memory map only while BDM is active.

The BDM control logic communicates with an external host development system serially, via the BKGD pin. This single-wire approach minimizes the number of pins needed for development support.

### 19.4.1 Enabling BDM Firmware Commands

BDM is available in all operating modes, but must be made active before firmware commands can be executed. BDM is enabled by setting the ENBDM bit in the BDM STATUS register via the single wire interface (using a hardware command; WRITE\_BD\_BYTE at \$FF01). BDM must then be activated to map BDM registers and ROM to addresses \$FF00 to \$FFFF and to put the MCU in active background mode.

After the firmware is enabled, BDM can be activated by the hardware BACKGROUND command, by the BDM tagging mechanism, or by the CPU BGND instruction. An attempt to activate BDM before firmware has been enabled causes the MCU to resume normal instruction execution after a brief delay.

BDM becomes active at the next instruction boundary following execution of the BDM BACKGROUND command, but tags activate BDM before a tagged instruction is executed.

In special single-chip mode, background operation is enabled and active immediately out of reset. This active case replaces the M68HC11 boot function, and allows programming a system with blank memory.

While BDM is active, a set of BDM control registers are mapped to addresses \$FF00 to \$FF06. The BDM control logic uses these registers which can be read anytime by BDM logic, not user programs. Refer to [BDM Registers](#) for detailed descriptions.

Some on-chip peripherals have a BDM control bit which allows suspending the peripheral function during BDM. For example, if the timer control is enabled, the timer counter is stopped while in BDM. Once normal program flow is continued, the timer counter is re-enabled to simulate real-time operations.

### 19.4.2 BDM Serial Interface

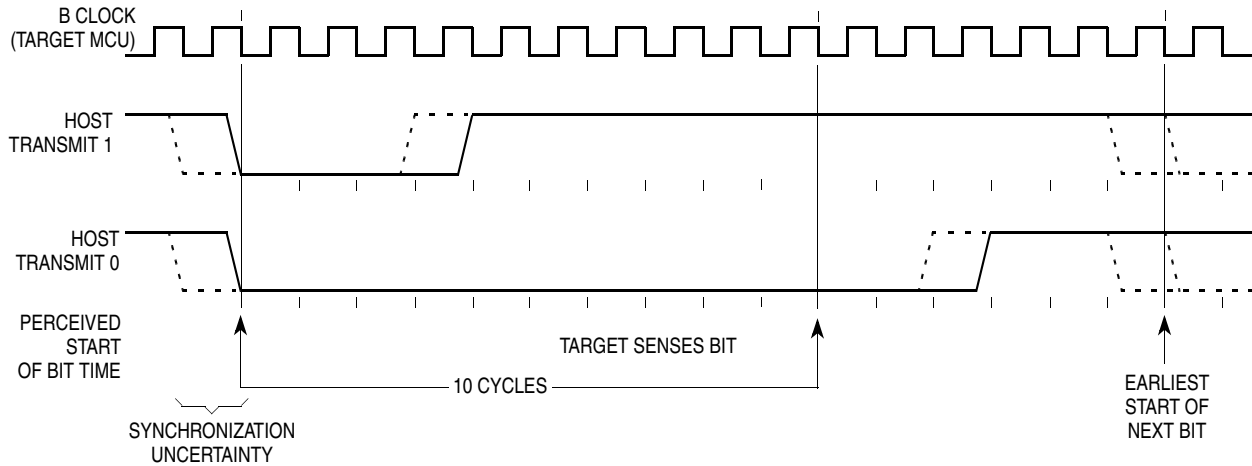
The BDM serial interface requires the external controller to generate a falling edge on the BKGD pin to indicate the start of each bit time. The external controller provides this falling edge whether data is transmitted or received.

BKGD is a pseudo-open-drain pin that can be driven either by an external controller or by the MCU. Data is transferred MSB first at 16 B-clock cycles per bit (nominal speed). The interface times out if 512 B-clock cycles occur between falling edges from the host. The hardware clears the command register when a time-out occurs.

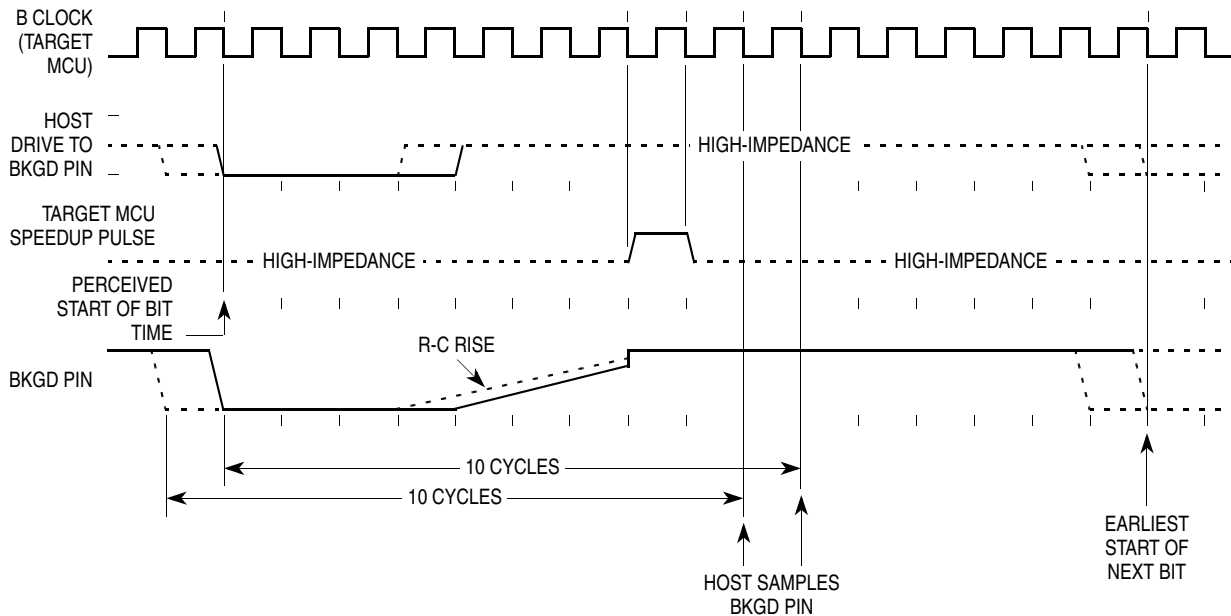
The BKGD pin can receive a high or low level or transmit a high or low level. The following diagrams show timing for each of these cases. Interface timing is synchronous to MCU clocks but asynchronous to the external host. The internal clock signal is shown for reference in counting cycles.

[Figure 19-1](#) shows an external host transmitting a logic one or zero to the BKGD pin of a target 68HC(9)12D60 MCU. The host is asynchronous to the target so there is a 0-to-1 cycle delay from the host-generated falling edge to where the target perceives the beginning of the bit time. Ten target B cycles later, the target senses the bit level on the BKGD pin. Typically the host actively drives the pseudo-open-drain BKGD pin

during host-to-target transmissions to speed up rising edges. Since the target does not drive the BKGD pin during this period, there is no need to treat the line as an open-drain signal during host-to-target transmissions.



**Figure 19-1. BDM Host to Target Serial Bit Timing**



**Figure 19-2. BDM Target to Host Serial Bit Timing (Logic 1)**

Figure 19-2 shows the host receiving a logic one from the target 68HC(9)12D60 MCU. Since the host is asynchronous to the target MCU, there is a 0-to-1 cycle delay from the host-generated falling edge on BKGD to the perceived start of the bit time in the target MCU. The host holds the BKGD pin low long enough for the target to recognize it (at least two target B cycles). The host must release the low drive before the target MCU drives a brief active-high speed-up pulse seven cycles after the perceived start of the bit time. The host should sample the bit level about ten cycles after it started the bit time.

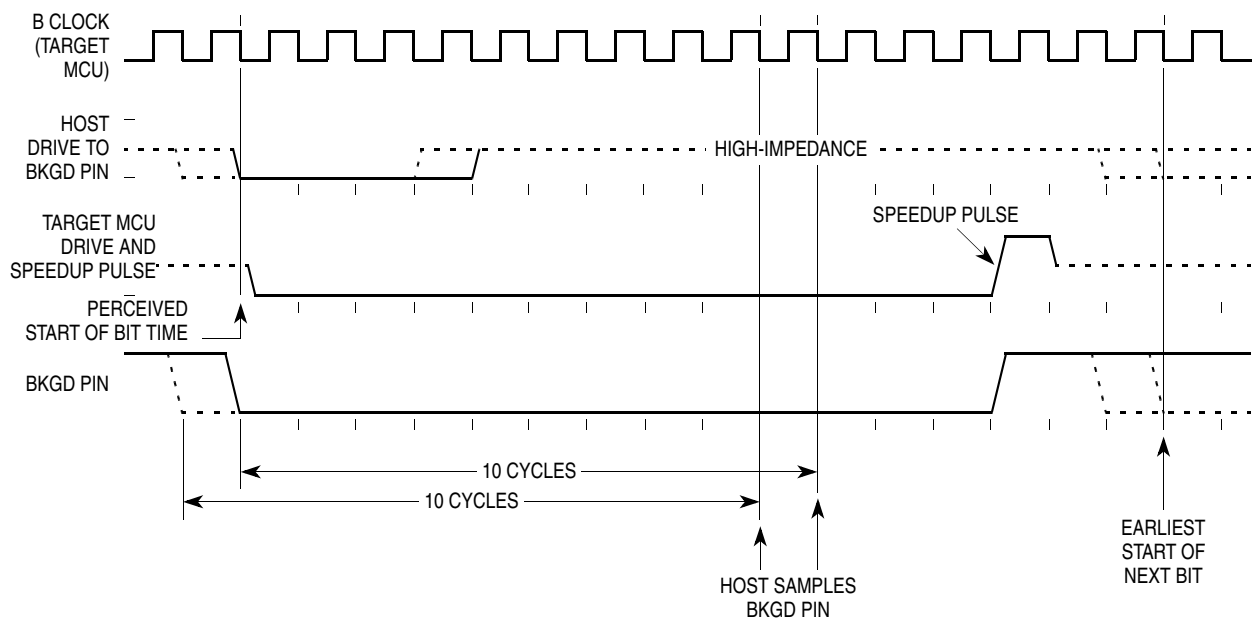


Figure 19-3. BDM Target to Host Serial Bit Timing (Logic 0)

Figure 19-3 shows the host receiving a logic zero from the target 68HC(9)12D60 MCU. Since the host is asynchronous to the target MCU, there is a 0-to-1 cycle delay from the host-generated falling edge on BKGD to the start of the bit time as perceived by the target MCU. The host initiates the bit time but the target 68HC(9)12D60 finishes it. Since the target wants the host to receive a logic zero, it drives the BKGD pin low for 13 B-clock cycles, then briefly drives it high to speed up the rising edge. The host samples the bit level about ten cycles after starting the bit time.

### 19.4.3 BDM Commands

The BDM command set consists of two types: hardware and firmware. Hardware commands allow target system memory to be read or written. Target system memory includes all memory that is accessible by the CPU12 including EEPROM, on-chip I/O and control registers, and external memory that is connected to the target HC12 MCU. Hardware commands are implemented in hardware logic and do not require the HC12 MCU to be in BDM mode for execution. The control logic watches the CPU12 buses to find a free bus cycle to execute the command so the background access does not disturb the running application programs. If a free cycle is not found within 128 B-clock cycles, the CPU12 is momentarily frozen so the control logic can steal a cycle. Commands implemented in BDM control logic are listed in [Table 19-2](#).

**Table 19-2. Hardware Commands<sup>(1)</sup>**

Command	Opcode (Hex)	Data	Description
BACKGROUND	90	None	Enter background mode if firmware enabled.
READ_BD_BYTE <sup>(1)</sup>	E4	16-bit address 16-bit data out	Read from memory with BDM in map (may steal cycles if external access) data for odd address on low byte, data for even address on high byte.
READ_BD_WORD <sup>(1)</sup>	EC	16-bit address 16-bit data out	Read from memory with BDM in map (may steal cycles if external access). Must be aligned access.
READ_BYTE	E0	16-bit address 16-bit data out	Read from memory with BDM out of map (may steal cycles if external access) data for odd address on low byte, data for even address on high byte.
READ_WORD	E8	16-bit address 16-bit data out	Read from memory with BDM out of map (may steal cycles if external access). Must be aligned access.
WRITE_BD_BYTE <sup>(1)</sup>	C4	16-bit address 16-bit data in	Write to memory with BDM in map (may steal cycles if external access) data for odd address on low byte, data for even address on high byte.
WRITE_BD_WORD <sup>(1)</sup>	CC	16-bit address 16-bit data in	Write to memory with BDM in map (may steal cycles if external access). Must be aligned access.
WRITE_BYTE	C0	16-bit address 16-bit data in	Write to memory with BDM out of map (may steal cycles if external access) data for odd address on low byte, data for even address on high byte.
WRITE_WORD	C8	16-bit address 16-bit data in	Write to memory with BDM out of map (may steal cycles if external access). Must be aligned access.

1. Use these commands only for reading/writing to BDM locations. The BDM firmware ROM and BDM registers are not normally in the HC12 MCU memory map. Since these locations have the same addresses as some of the normal application memory map, there needs to be a way to decide which physical locations are being accessed by the hardware BDM commands. This gives rise to needing separate memory access commands for the BDM locations as opposed to the normal application locations. In logic, this is accomplished by momentarily enabling the BDM memory resources, just for the access cycles of the READ\_BD and WRITE\_BD commands. This logic allows the debugging system to unobtrusively access the BDM locations even if the application program is running out of the same memory area in the normal application memory map.

The second type of BDM commands are firmware commands implemented in a small ROM within the HC12 MCU. The CPU must be in background mode to execute firmware commands. The usual way to get to background mode is by the hardware command BACKGROUND. The BDM ROM is located at \$FFF20 to \$FFFF while BDM is active. There are also seven bytes of BDM registers located at \$FF00 to \$FF06 when BDM is active. The CPU executes code in the BDM firmware to perform the requested operation. The BDM firmware watches for serial commands and executes them as they are received. The firmware commands are shown in [Table 19-3](#).



**Table 19-3. BDM Firmware Commands**

Command	Opcode (Hex)	Data	Description
READ_NEXT	62	16-bit data out	$X = X + 2$ ; Read next word pointed to by X
READ_PC	63	16-bit data out	Read program counter
READ_D	64	16-bit data out	Read D accumulator
READ_X	65	16-bit data out	Read X index register
READ_Y	66	16-bit data out	Read Y index register
READ_SP	67	16-bit data out	Read stack pointer
WRITE_NEXT	42	16-bit data in	$X = X + 2$ ; Write next word pointed to by X
WRITE_PC	43	16-bit data in	Write program counter
WRITE_D	44	16-bit data in	Write D accumulator
WRITE_X	45	16-bit data in	Write X index register
WRITE_Y	46	16-bit data in	Write Y index register
WRITE_SP	47	16-bit data in	Write stack pointer
GO	08	None	Go to user program
TRACE1	10	None	Execute one user instruction then return to BDM
TAGGO	18	None	Enable tagging and go to user program

Each of the hardware and firmware BDM commands start with an 8-bit command code (opcode). Depending upon the commands, a 16-bit address and/or a 16-bit data word is required as indicated in the tables by the command. All the read commands output 16-bits of data despite the byte/word implication in the command name.

The external host should wait 150 BCLK cycles for a non-intrusive BDM command to execute before another command is sent. This delay includes 128 BCLK cycles for the maximum delay for a free cycle. For data read commands, the host must insert this delay between sending the address and attempting to read the data. In the case of a write command, the host must delay after the data portion before sending a new command to be sure that the write has finished.

The external host should delay about 32 target BCLK cycles between a firmware read command and the data portion of these commands. This allows the BDM firmware to execute the instructions needed to get the requested data into the BDM SHIFTER register.

The external host should delay about 32 target BCLK cycles after the data portion of firmware write commands to allow BDM firmware to complete the requested write operation before a new serial command disturbs the BDM SHIFTER register.

The external host should delay about 64 target BCLK cycles after a TRACE1 or GO command before starting any new serial command. This delay is needed because the BDM SHIFTER register is used as a temporary data holding register during the exit sequence to user code.

BDM logic retains control of the internal buses until a read or write is completed. If an operation can be completed in a single cycle, it does not intrude on normal CPU12 operation. However, if an operation requires multiple cycles, CPU12 clocks are frozen until the operation is complete.

### 19.4.4 BDM Lockout

The access to the MCU resources by BDM may be prevented by enabling the BDM lockout feature. When enabled, the BDM lockout mechanism prevents the BDM from being active. In this case the BDM ROM is disabled and does not appear in the MCU memory map.

BDM lockout is enabled by clearing NOBDML bit of EEMCR register. The NOBDML bit is loaded at reset from the SHADOW byte of EEPROM module. Modifying the state of the NOBDML and corresponding EEPROM SHADOW bit is only possible in special modes.

Please refer to [EEPROM Memory](#) for NOBDML information.

### 19.4.5 Enabling BDM lockout

Enabling the BDM lockout feature is only possible in special modes (SMODN=0) and is accomplished by the following steps.

1. Remove the SHADOW byte protection by clearing SHPROT bit in EEPROT register.
2. Clear NOSHB bit in EEMCR register to make the SHADOW byte visible at \$0FC0.
3. Program bit 7 of the SHADOW byte like a regular EEPROM

location at address \$0FC0 (write \$7F into address \$0FC0). Do not program other bits of the SHADOW byte (location \$0FC0); otherwise some regular EEPROM array locations will not be visible. At the next reset, the SHADOW byte is loaded into the EEMCR register. NOBDML bit in EEMCR will be cleared and BDM will not be operational.

4. Protect the SHADOW byte by setting SHPROT bit in EEPROT register.

### 19.4.6 Disabling BDM lockout

Disabling the BDM lockout is only possible in special modes (SMODN=0) except in special single chip mode. Follow the same steps as for enabling the BDM lockout, but erase the SHADOW byte.

At the next reset, the SHADOW byte is loaded into the EEMCR register. NOBDML bit in EEMCR will be set and BDM becomes operational.

**NOTE:** *When the BDM lockout is enabled it is not possible to run code from the reset vector in special single chip mode.*

### 19.4.7 BDM Registers

Seven BDM registers are mapped into the standard 64-Kbyte address space when BDM is active. Mapping is shown in [Table 19-4](#).

**Table 19-4. BDM registers**

Address	Register
\$FF00	BDM Instruction Register
\$FF01	BDM Status Register
\$FF02 - \$FF03	BDM Shift Register
\$FF04 - \$FF05	BDM Address Register
\$FF06	BDM CCR Holding Register

- The INSTRUCTION register content is determined by the type of background command being executed.
- The STATUS register indicates BDM operating conditions.

- The SHIFT register contains data being received or transmitted via the serial interface.
- The ADDRESS register is temporary storage for BDM commands.
- The CCRSAV register preserves the content of the CPU12 CCR while BDM is active.

The only registers of interest to users are the STATUS register and the CCRSAV register. The other BDM registers are only used by the BDM firmware to execute commands. The registers are accessed by means of the hardware READ\_BD and WRITE\_BD commands, but should not be written during BDM operation (except the CCRSAV register which could be written to modify the CCR value).

## 19.4.8 STATUS

The STATUS register is read and written by the BDM hardware as a result of serial data shifted in on the BKGD pin.

Read: all modes.

Write: Bits 3 through 5, and bit 7 are writable in all modes. Bit 6, BDMACT, can only be written if bit 7 H/F in the INSTRUCTION register is a zero. Bit 2, CLKSW, can only be written if bit 7 H/F in the INSTRUCTION register is a one. A user would never write ones to bits 3 through 5 because these bits are only used by BDM firmware.

	BIT 7	6	5	4	3	2	1	BIT 0	
	ENBDM	BDMACT	ENTAG	SDV	TRACE	CLKSW	-	-	
RESET:	0 (NOTE 1)	1	0	0	0	0	0	0	Special Single Chip & Periph
RESET:	0	0	0	0	0	0	0	0	All other modes

**STATUS**— BDM Status Register<sup>(1)</sup>

**\$FF01**

1. ENBDM is set to 1 by the firmware in Special Single Chip mode.

ENBDM — Enable BDM (permit active background debug mode)

0 = BDM cannot be made active (hardware commands still allowed).

1 = BDM can be made active to allow firmware commands.

BDMACT — Background Mode Active Status

BDMACT becomes set as active BDM mode is entered so that the BDM firmware ROM is enabled and put into the map. BDMACT is cleared by a carefully timed store instruction in the BDM firmware as part of the exit sequence to return to user code and remove the BDM memory from the map. This bit has 4 clock cycles write delay.

0 = BDM is not active. BDM ROM and registers are not in map.

1 = BDM is active and waiting for serial commands. BDM ROM and registers are in map

The user should be careful that the state of the BDMACT bit is not unintentionally changed with the WRITE\_NEXT firmware command. If it is unintentionally changed from 1 to 0, it will cause a system runaway because it would disable the BDM firmware ROM while the CPU12 was executing BDM firmware. The following two commands show how BDMACT may unintentionally get changed from 1 to 0.

WRITE\_X with data \$FEFE

WRITE\_NEXT with data \$C400

The first command writes the data \$FEFE to the X index register. The second command writes the data \$C4 to the \$FF00 INSTRUCTION register and also writes the data \$00 to the \$FF01 STATUS register.

ENTAG — Tagging Enable

Set by the TAGGO command and cleared when BDM mode is entered. The serial system is disabled and the tag function enabled 16 cycles after this bit is written.

0 = Tagging not enabled, or BDM active.

1 = Tagging active. BDM cannot process serial commands while tagging is active.

## SDV — Shifter Data Valid

Shows that valid data is in the serial interface shift register. Used by the BDM firmware.

0 = No valid data. Shift operation is not complete.

1 = Valid Data. Shift operation is complete.

## TRACE — Asserted by the TRACE1 command

## CLKSW — Clock Switch

0 = BDM system operates with BCLK.

1 = BDM system operates with ECLK.

The WRITE\_BD\_BYTE@FF01 command that changes CLKSW including 150 cycles after the data portion of the command should be timed at the old speed. Beginning with the start of the next BDM command, the new clock can be used for timing BDM communications.

If ECLK rate is slower than BCLK rate, CLKSW is ignored and BDM system is forced to operate with ECLK.

## 19.4.9 INSTRUCTION - Hardware Instruction Decode

The INSTRUCTION register is written by the BDM hardware as a result of serial data shifted in on the BKGND pin. It is readable and writable in Special Peripheral mode on the parallel bus. It is discussed here for two conditions: when a **hardware** command is executed and when a **firmware** command is executed.

Read and write: all modes

The hardware clears the INSTRUCTION register if 512 BCLK cycles occur between falling edges from the host.

	BIT 7	6	5	4	3	2	1	BIT 0
	H/F	DATA	R/W	BKGND	W/B	BD/U	0	0
RESET:	0	0	0	0	0	0	0	0

**INSTRUCTION** — BDM Instruction Register (hardware command explanation)

**\$FF00**

The bits in the BDM instruction register have the following meanings when a **hardware** command is executed.

H/F — Hardware/Firmware Flag

0 = Firmware command

1 = Hardware command

DATA — Data Flag - Shows that data accompanies the command.

0 = No data

1 = Data follows the command

R/W — Read/Write Flag

0 = Write

1 = Read

BKGND — Hardware request to enter active background mode

0 = Not a hardware background command

1 = Hardware background command (INSTRUCTION = \$90)

W/B — Word/Byte Transfer Flag

0 = Byte transfer

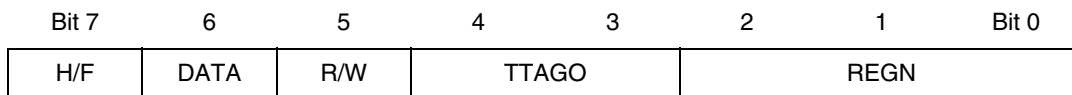
1 = Word transfer

BD/U — BDM Map/User Map Flag

Indicates whether BDM registers and ROM are mapped to addresses \$FF00 to \$FFFF in the standard 64-Kbyte address space. Used only by hardware read/write commands.

0 = BDM resources not in map

1 = BDM ROM and registers in map



**INSTRUCTION** — BDM Instruction Register (firmware command bit explanation)

**\$FF00**

The bits in the BDM instruction register have the following meanings when a **firmware** command is executed.

H/F — Hardware/Firmware Flag

0 = Firmware command

1 = Hardware command

DATA — Data Flag - Shows that data accompanies the command.

0 = No data

1 = Data follows the command

R/W — Read/Write Flag

0 = Write

1 = Read

TTAGO — Trace, Tag, Go Field

**Table 19-5. TTAGO Decoding**

Table 19-6TTAGO Value	Table 19-7Instruction
00	—
01	GO
10	TRACE1
11	TAGGO

REGN — Register/Next Field

Indicates which register is being affected by a command. In the case of a READ\_NEXT or WRITE\_NEXT command, index register X is pre-incremented by 2 and the word pointed to by X is then read or written.

**Table 19-8. REGN Decoding**

REGN Value	Instruction
000	—
001	—
010	READ/WRITE NEXT
011	PC
100	D
101	X
110	Y
111	SP

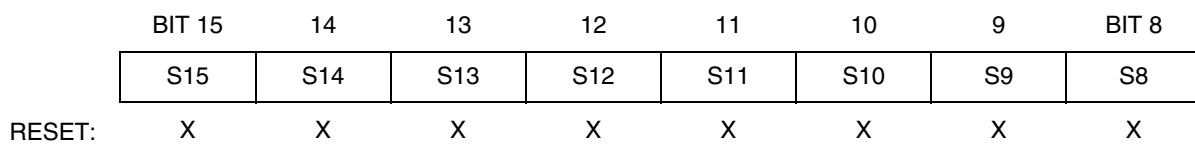


### 19.4.10 SHIFTER

This 16-bit shift register contains data being received or transmitted via the serial interface. It is also used by the BDM firmware for temporary storage.

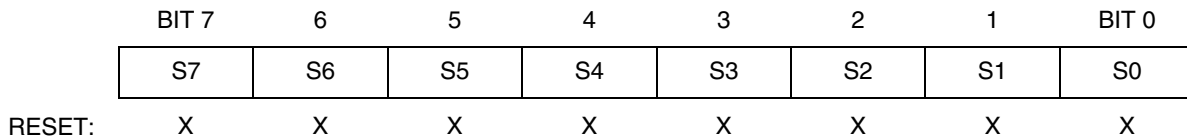
Read: all modes (but not normally accessed by users)

Write: all modes (but not normally accessed by users)



**SHIFTER**— BDM Shift Register - High Byte

**\$FF02**



**SHIFTER**— BDM Shift Register - Low Byte

**\$FF03**

## 19.4.11 ADDRESS

This 16-bit address register is temporary storage for BDM hardware and firmware commands.

Read: all modes (but not normally accessed by users)

Write: only by BDM hardware (state machine)

	BIT 15	14	13	12	11	10	9	BIT 8
	A15	A14	A13	A12	A11	A10	A9	A8
RESET:	X	X	X	X	X	X	X	X

**ADDRESS**— BDM Address Register - High Byte

**\$FF04**

	BIT 7	6	5	4	3	2	1	BIT 0
	A7	A6	A5	A4	A3	A2	A1	A0
RESET:	X	X	X	X	X	X	X	X

**ADDRESS**— BDM Address Register - Low Byte

**\$FF05**

## 19.4.12 CCRSAV

The CCRSAV register is used to save the CCR of the users program when entering BDM. It is also used for temporary storage in the BDM firmware.

Read and write: all modes

	BIT 7	6	5	4	3	2	1	BIT 0
	CCR7	CCR6	CCR5	CCR4	CCR3	CCR2	CCR1	CCR0
RESET: NOTE 1 <sup>(1)</sup>	X	X	X	X	X	X	X	X

**CCRSV**— BDM CCR Holding Register

**\$FF06**

1. Initialized to equal the CPU12 CCR register by the firmware.

## 19.5 Breakpoints

Hardware breakpoints are used to debug software on the 68HC(9)12D60 by comparing actual address and data values to predetermined data in setup registers. A successful comparison will place the CPU in background debug mode (BDM) or initiate a software interrupt (SWI). Breakpoint features designed into the 68HC(9)12D60 include:

- Mode selection for BDM or SWI generation
- Program fetch tagging for cycle of execution breakpoint
- Second address compare in dual address modes
- Range compare by disable of low byte address
- Data compare in full feature mode for non-tagged breakpoint
- Byte masking for high/low byte data compares
- $R/\overline{W}$  compare for non-tagged compares
- Tag inhibit on BDM TRACE

### 19.5.1 Breakpoint Modes

Three modes of operation determine the type of breakpoint in effect.

- Dual address-only breakpoints, each of which will cause a software interrupt (SWI)
- Single full-feature breakpoint which will cause the part to enter background debug mode (BDM)
- Dual address-only breakpoints, each of which will cause the part to enter BDM

Breakpoints will not occur when BDM is active.

### 19.5.2 SWI Dual Address Mode

In this mode, dual address-only breakpoints can be set, each of which cause a software interrupt. This is the only breakpoint mode which can force the CPU to execute a SWI. Program fetch tagging is the default in this mode; data breakpoints are not possible. In the dual mode each address breakpoint is affected by the BKPM bit and the BKALE bit. The BKxRW and BKxRWE bits are ignored. In dual address mode the BKDBE becomes an enable for the second address breakpoint. The BKSZ8 bit will have no effect when in a dual address mode.

### 19.5.3 BDM Full Breakpoint Mode

A single full feature breakpoint which causes the part to enter background debug mode. BDM mode may be entered by a breakpoint only if an internal signal from the BDM indicates background debug mode is enabled.

- Breakpoints are not allowed if the BDM mode is already active. Active mode means the CPU is executing out of the BDM ROM.
- BDM should not be entered from a breakpoint unless the ENABLE bit is set in the BDM. This is important because even if the ENABLE bit in the BDM is negated the CPU actually does execute

the BDM ROM code. It checks the ENABLE and returns if not set. If the BDM is not serviced by the monitor then the breakpoint would be re-asserted when the BDM returns to normal CPU flow.

- There is no hardware to enforce restriction of breakpoint operation if the BDM is not enabled.

#### 19.5.4 BDM Dual Address Mode

Dual address-only breakpoints, each of which cause the part to enter background debug mode. In the dual mode each address breakpoint is affected, consistent across modes, by the BKPM bit, the BKALE bit, and the BKxRW and BKxRWE bits. In dual address mode the BKDBE becomes an enable for the second address breakpoint. The BKSZ8 bit will have no effect when in a dual address mode. BDM mode may be entered by a breakpoint only if an internal signal from the BDM indicates background debug mode is enabled.

- BKDBE will be used as an enable for the second address only breakpoint.
- Breakpoints are not allowed if the BDM mode is already active. Active mode means the CPU is executing out of the BDM ROM.
- BDM should not be entered from a breakpoint unless the ENABLE bit is set in the BDM. This is important because even if the ENABLE bit in the BDM is negated the CPU actually does execute the BDM ROM code. It checks the ENABLE and returns if not set. If the BDM is not serviced by the monitor then the breakpoint would be re-asserted when the BDM returns to normal CPU flow. There is no hardware to enforce restriction of breakpoint operation if the BDM is not enabled.

#### 19.5.5 Breakpoint Registers

Breakpoint operation consists of comparing data in the breakpoint address registers (BRKAH/BRKAL) to the address bus and comparing data in the breakpoint data registers (BRKDH/BRKDL) to the data bus. The breakpoint data registers can also be compared to the address bus.

The scope of comparison can be expanded by ignoring the least significant byte of address or data matches.

The scope of comparison can be limited to program data only by setting the BKPM bit in breakpoint control register 0.

To trace program flow, setting the BKPM bit causes address comparison of program data only. Control bits are also available that allow checking read/write matches.

	Bit 7	6	5	4	3	2	1	Bit 0
	BKEN1	BKEN0	BKPM	0	BK1ALE	BK0ALE	0	0
RESET:	0	0	0	0	0	0	0	0

**BRKCT0** — Breakpoint Control Register 0

**\$0020**

Read and write anytime.

This register is used to control the breakpoint logic.

BKEN1, BKEN0 — Breakpoint Mode Enable

**Table 19-9. Breakpoint Mode Control**

BKEN1	BKEN0	Mode Selected	BRKAH/L Usage	BRKDH/L Usage	R/W	Range
0	0	Breakpoints Off	—	—	—	—
0	1	SWI — Dual Address Mode	Address Match	Address Match	No	Yes
1	0	BDM — Full Breakpoint Mode	Address Match	Data Match	Yes	Yes
1	1	BDM — Dual Address Mode	Address Match	Address Match	Yes	Yes

**BKPM** — Break on Program Addresses

This bit controls whether the breakpoint will cause a break on a match (next instruction boundary) or on a match that will be an executable opcode. Data and non-executed opcodes cannot cause a break if this bit is set. This bit has no meaning in SWI dual address mode. The SWI mode only performs program breakpoints.

0 = On match, break at the next instruction boundary

1 = On match, break if the match is an instruction that will be executed. This uses tagging as its breakpoint mechanism.

**BK1ALE — Breakpoint 1 Range Control**

Only valid in dual address mode.

0 = BRKDL will not be used to compare to the address bus.

1 = BRKDL will be used to compare to the address bus.

**BK0ALE — Breakpoint 0 Range Control**

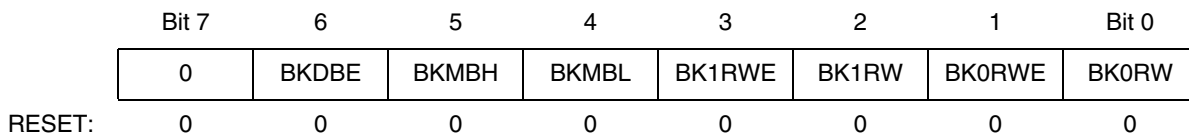
Valid in all modes.

0 = BRKAL will not be used to compare to the address bus.

1 = BRKAL will be used to compare to the address bus.

**Table 19-10. Breakpoint Address Range Control**

BK1ALE	BK0ALE	Address Range Selected
–	0	Upper 8-bit address only for full mode or dual mode BKP0
–	1	Full 16-bit address for full mode or dual mode BKP0
0	–	Upper 8-bit address only for dual mode BKP1
1	–	Full 16-bit address for dual mode BKP1



**BRKCT1** — Breakpoint Control Register 1

**\$0021**

This register is read/write in all modes.

**BKDBE — Enable Data Bus**

Enables comparing of address or data bus values using the BRKDH/L registers.

0 = The BRKDH/L registers are not used in any comparison

1 = The BRKDH/L registers are used to compare address or data (depending upon the mode selections BKEN1,0)

### BKMBH — Breakpoint Mask High

Disables the comparing of the high byte of data when in full breakpoint mode. Used in conjunction with the BKDBE bit (which should be set)

0 = High byte of data bus (bits 15:8) are compared to BRKDH

1 = High byte is not used in comparisons

### BKMBL — Breakpoint Mask Low

Disables the matching of the low byte of data when in full breakpoint mode. Used in conjunction with the BKDBE bit (which should be set)

0 = Low byte of data bus (bits 7:0) are compared to BRKDL

1 = Low byte is not used in comparisons.

### BK1RWE — $R/\overline{W}$ Compare Enable

Enables the comparison of the  $R/\overline{W}$  signal to further specify what causes a match. This bit is NOT useful in program breakpoints or in full breakpoint mode. This bit is used in conjunction with a second address in dual address mode when BKDBE=1.

0 = R/W is not used in comparisons

1 = R/W is used in comparisons

### BK1RW — $R/\overline{W}$ Compare Value

When BK1RWE = 1, this bit determines the type of bus cycle to match.

0 = A write cycle will be matched

1 = A read cycle will be matched

### BK0RWE — $R/\overline{W}$ Compare Enable

Enables the comparison of the  $R/\overline{W}$  signal to further specify what causes a match. This bit is not useful in program breakpoints.

0 =  $R/\overline{W}$  is not used in the comparisons

1 =  $R/\overline{W}$  is used in comparisons

### BK0RW — $R/\overline{W}$ Compare Value

When BK0RWE = 1, this bit determines the type of bus cycle to match on.

0 = Write cycle will be matched

1 = Read cycle will be matched



**Table 19-11. Breakpoint Read/Write Control**

BK1RWE	BK1RW	BK0RWE	BK0RW	Read/Write Selected
–	–	0	X	R/W is don't care for full mode or dual mode BKP0
–	–	1	0	R/W is write for full mode or dual mode BKP0
–	–	1	1	R/W is read for full mode or dual mode BKP0
0	X	–	–	R/W is don't care for dual mode BKP1
1	0	–	–	R/W is write for dual mode BKP1
1	1	–	–	R/W is read for dual mode BKP1

Bit 7	6	5	4	3	2	1	Bit 0
Bit 15	14	13	12	11	10	9	Bit 8
RESET:	0	0	0	0	0	0	0

**BRKAH** — Breakpoint Address Register, High Byte

**\$0022**

These bits are used to compare against the most significant byte of the address bus.

Bit 7	6	5	4	3	2	1	Bit 0
Bit 7	6	5	4	3	2	1	Bit 0
RESET:	0	0	0	0	0	0	0

**BRKAL** — Breakpoint Address Register, Low Byte

**\$0023**

These bits are used to compare against the least significant byte of the address bus. These bits may be excluded from being used in the match if BK0ALE = 0.

Bit 7	6	5	4	3	2	1	Bit 0
Bit 15	14	13	12	11	10	9	Bit 8
RESET:	0	0	0	0	0	0	0

**BRKDH** — Breakpoint Data Register, High Byte

**\$0024**

These bits are compared to the most significant byte of the data bus or the most significant byte of the address bus in dual address modes. **BKEN[1:0]**, **BKDBE**, and **BKMBH** control how this byte will be used in the breakpoint comparison.

Bit 7	6	5	4	3	2	1	Bit 0
Bit 7	6	5	4	3	2	1	Bit 0
RESET:	0	0	0	0	0	0	0

**BRKDL** — Breakpoint Data Register, Low Byte

**\$0025**

These bits are compared to the least significant byte of the data bus or the least significant byte of the address bus in dual address modes. **BKEN[1:0]**, **BKDBE**, **BK1ALE**, and **BKMBL** control how this byte will be used in the breakpoint comparison.

## 19.6 Instruction Tagging

The instruction queue and cycle-by-cycle CPU activity can be reconstructed in real time or from trace history that was captured by a logic analyzer. However, the reconstructed queue cannot be used to stop the CPU at a specific instruction, because execution has already begun by the time an operation is visible outside the MCU. A separate instruction tagging mechanism is provided for this purpose.

Executing the **BDM TAGGO** command configures two MCU pins for tagging. The **TAGLO** signal shares a pin with the **LSTRB** signal, and the

$\overline{\text{TAGHI}}$  signal shares a pin with the BKGD signal. Tagging information is latched on the falling edge of ECLK.

Table 19-12 shows the functions of the two tagging pins. The pins operate independently - the state of one pin does not affect the function of the other. The presence of logic level zero on either pin at the fall of ECLK performs the indicated function. Tagging is allowed in all modes. Tagging is disabled when BDM becomes active and BDM serial commands are not processed while tagging is active.

**Table 19-12. Tag Pin Function**

TAGHI	TAGLO	Tag
1	1	no tag
1	0	low byte
0	1	high byte
0	0	both bytes

The tag follows program information as it advances through the queue. When a tagged instruction reaches the head of the queue, the CPU enters active background debugging mode rather than execute the instruction.



## Section 20. Electrical Specifications

### 20.1 Contents

20.2	Introduction . . . . .	365
20.3	Tables of Data . . . . .	366

### 20.2 Introduction

This section contains the most accurate electrical information for the 68HC(9)12D60 microcontroller available at the time of publication.

## 20.3 Tables of Data

**Table 20-1. Maximum Ratings<sup>(1)</sup>**

Rating	Symbol	Value	Unit
Supply voltage	$V_{DD}, V_{DDA}, V_{DDX}, V_{DDPLL}$	-0.3 to +6.5	V
Input voltage	$V_{IN}$	-0.3 to +6.5	V
Operating temperature range 68HC(9)12D60PV8 68HC(9)12D60CPV8 68HC(9)12D60VPV8 68HC(9)12D60MPV8 (single chip mode only)	$T_A$	$T_L$ to $T_H$ 0 to +70 -40 to +85 -40 to +105 -40 to +125	°C
Operating temperature range 68HC(9)12D60FU8 68HC(9)12D60CFU8 68HC(9)12D60VFU8 68HC(9)12D60MFU8 (single chip mode only)	$T_A$	$T_L$ to $T_H$ 0 to +70 -40 to +85 -40 to +105 -40 to +125	°C
Storage temperature range	$T_{stg}$	-55 to +150	°C
Current drain per pin <sup>(2)</sup> Excluding $V_{DD}$ and $V_{SS}$	$I_{IN}$	±25	mA
$V_{DD}$ differential voltage	$V_{DD}-V_{DDX}$	6.5	V

1. Permanent damage can occur if maximum ratings are exceeded. Exposures to voltages or currents in excess of recommended values affects device reliability. Device modules may not operate normally while being exposed to electrical extremes.
2. One pin at a time, observing maximum power dissipation limits. Internal circuitry protects the inputs against damage caused by high static voltages or electric fields; however, normal precautions are necessary to avoid application of any voltage higher than maximum-rated voltages to this high-impedance circuit. Extended operation at the maximum ratings can adversely affect device reliability. Tying unused inputs to an appropriate logic voltage level (either GND or  $V_{DD}$ ) enhances reliability of operation.

**Table 20-2. Thermal Characteristics**

Characteristic	Symbol	Value	Unit
Average junction temperature	$T_J$	$T_A + (P_D \times \Theta_{JA})$	$^{\circ}\text{C}$
Ambient temperature	$T_A$	User-determined	$^{\circ}\text{C}$
Package thermal resistance (junction-to-ambient) 68HC912D60 80-pin quad flat pack (QFP) 112-pin thin quad flat pack (TQFP)	$\Theta_{JA}$	65 46	$^{\circ}\text{C}/\text{W}$
Package thermal resistance (junction-to-ambient) 68HC12D60 80-pin quad flat pack (QFP) 112-pin thin quad flat pack (TQFP)	$\Theta_{JA}$	70 48	$^{\circ}\text{C}/\text{W}$
Total power dissipation <sup>(1)</sup>	$P_D$	$P_{INT} + P_{I/O}$ or $\frac{K}{T_J + 273^{\circ}\text{C}}$	W
Device internal power dissipation	$P_{INT}$	$I_{DD} \times V_{DD}$	W
I/O pin power dissipation <sup>(2)</sup>	$P_{I/O}$	User-determined	W
A constant <sup>(3)</sup>	K	$P_D \times (T_A + 273^{\circ}\text{C}) +$ $\Theta_{JA} \times P_D^2$	$\text{W} \cdot ^{\circ}\text{C}$

1. This is an approximate value, neglecting  $P_{I/O}$ .

2. For most applications  $P_{I/O} \ll P_{INT}$  and can be neglected.

3. K is a constant pertaining to the device. Solve for K with a known  $T_A$  and a measured  $P_D$  (at equilibrium). Use this value of K to solve for  $P_D$  and  $T_J$  iteratively for any value of  $T_A$ .

# Electrical Specifications

**Table 20-3. DC Electrical Characteristics**

$V_{DD} = 5.0 \text{ Vdc} \pm 10\%$ ,  $V_{SS} = 0 \text{ Vdc}$ ,  $T_A = T_L$  to  $T_H$ , unless otherwise noted

Characteristic	Symbol	Min	Max	Unit
Input high voltage, all inputs	$V_{IH}$	$0.7 \times V_{DD}$	$V_{DD} + 0.3$	V
Input low voltage, all inputs	$V_{IL}$	$V_{SS} - 0.3$	$0.2 \times V_{DD}$	V
Output high voltage, all I/O and output pins except XTAL Normal drive strength $I_{OH} = -10.0 \mu\text{A}$ $I_{OH} = -0.8 \text{ mA}$ Reduced drive strength $I_{OH} = -4.0 \mu\text{A}$ $I_{OH} = -0.3 \text{ mA}$	$V_{OH}$	$V_{DD} - 0.2$ $V_{DD} - 0.8$ $V_{DD} - 0.2$ $V_{DD} - 0.8$	— — — —	V V V V
Output low voltage, all I/O and output pins except XTAL Normal drive strength $I_{OL} = 10.0 \mu\text{A}$ $I_{OL} = 1.6 \text{ mA}$ Reduced drive strength $I_{OL} = 3.6 \mu\text{A}$ $I_{OL} = 0.6 \text{ mA}$	$V_{OL}$	— — — —	$V_{SS} + 0.2$ $V_{SS} + 0.4$ $V_{SS} + 0.2$ $V_{SS} + 0.4$	V V V V
Input leakage current <sup>(1)</sup> $V_{in} = V_{DD}$ or $V_{SS}$ All input only pins except ATD <sup>(2)</sup> and $V_{FP}$ $V_{in} = V_{DD}$ or $V_{SS}$	$I_{in}$	— —	$\pm 2.5$ $\pm 10$	$\mu\text{A}$ $\mu\text{A}$
Three-state leakage, I/O ports, BKGD, and $\overline{\text{RESET}}$	$I_{OZ}$	—	$\pm 2.5$	$\mu\text{A}$
Input capacitance All input pins and ATD pins (non-sampling) ATD pins (sampling) All I/O pins	$C_{in}$	— — —	10 15 20	pF pF pF
Output load capacitance All outputs except PS[7:4] PS[7:4] when configured as SPI	$C_L$	— —	90 200	pF pF
Programmable active pull-up current XIRQ, IRQ, DBE, LSTRB, R/W, ports A, B, CAN, P,S, T MODA, MODB active pull down during reset BKGD passive pull up	$I_{APU}$	50 50 50	500 500 500	$\mu\text{A}$ $\mu\text{A}$ $\mu\text{A}$

1. Specification is for parts in the -40 to +85°C range. Higher temperature ranges will result in increased current leakage.

2. See [Table 20-5](#).



**Table 20-4. Supply Current**

$V_{DD} = 5.0 \text{ Vdc} \pm 10\%$ ,  $V_{SS} = 0 \text{ Vdc}$ ,  $T_A = T_L$  to  $T_H$ , unless otherwise noted

Characteristic	Symbol	2 MHz <sup>(1)</sup>	4 MHz <sup>(1)</sup>	8 MHz	Unit
Maximum total supply current					
<b>RUN:</b>					
Single-chip mode	$I_{DD}$	18	30	50	mA
Expanded mode		30	50	85	mA
<b>WAIT:</b> (All peripheral functions shut down)					
Single-chip mode	$W_{IDD}$	4	6	8	mA
Expanded mode		5	9	12	mA
<b>STOP:</b>					
Single-chip mode, no clocks	$S_{IDD}$	10	10	10	$\mu\text{A}$
–40 to +85		50	50	50	$\mu\text{A}$
+85 to +105		50	50	50	$\mu\text{A}$
+105 to +125		50	50	50	$\mu\text{A}$
Maximum power dissipation <sup>(2)</sup>					
Single-chip mode	$P_D$	100	165	275	mW
Expanded mode		165	275	467	mW

1. These are typical values only and are not tested.
2. Includes  $I_{DD}$  and  $I_{DDA}$ .

**Table 20-5. ATD DC Electrical Characteristics**

$V_{DD} = 5.0 \text{ Vdc} \pm 10\%$ ,  $V_{SS} = 0 \text{ Vdc}$ ,  $T_A = T_L$  to  $T_H$ , ATD Clock = 2 MHz, unless otherwise noted

Characteristic	Symbol	Min	Max	Unit
Analog supply voltage	$V_{DDA}$	4.5	5.5	V
Analog supply current, normal operation <sup>(1)</sup>	$I_{DDA}$		1.0	mA
Reference voltage, low	$V_{RL}$	$V_{SSA}$	$V_{DDA}/2$	V
Reference voltage, high	$V_{RH}$	$V_{DDA}/2$	$V_{DDA}$	V
$V_{REF}$ differential reference voltage <sup>(2)</sup>	$V_{RH} - V_{RL}$	4.5	5.5	V
Input voltage <sup>(3)</sup>	$V_{INDC}$	$V_{SSA}$	$V_{DDA}$	V
Input current, off channel <sup>(4)</sup>	$I_{OFF}$		100	nA
Reference supply current	$I_{REF}$		250	$\mu\text{A}$
Input capacitance	Not Sampling Sampling	$C_{INN}$ $C_{INS}$	10 15	pF pF

1. For **each** ATD module
2. Accuracy is guaranteed at  $V_{RH} - V_{RL} = 5.0\text{V} \pm 10\%$ .
3. To obtain full-scale, full-range results,  $V_{SSA} \leq V_{RL} \leq V_{INDC} \leq V_{RH} \leq V_{DDA}$ .
4. Maximum leakage occurs at maximum operating temperature. Current decreases by approximately one-half for each 10°C decrease from maximum temperature.

# Electrical Specifications

**Table 20-6. Analog Converter Characteristics (Operating)**

$V_{DD} = 5.0 \text{ Vdc} \pm 10\%$ ,  $V_{SS} = 0 \text{ Vdc}$ ,  $T_A = T_L$  to  $T_H$ , ATD Clock = 2 MHz, unless otherwise noted

Characteristic	Symbol	Min	Typical	Max	Unit
8-bit resolution <sup>(1)</sup>	1 count		20		mV
8-bit differential non-linearity <sup>(2)</sup>	DNL	-0.5		+0.5	count
8-bit integral non-linearity <sup>(2)</sup>	INL	-1		+1	count
8-bit absolute error <sup>(3)</sup> 2, 4, 8, and 16 ATD sample clocks	AE	-1		+1	count

10-bit resolution <sup>(1)</sup>	1 count		5		mV
10-bit differential non-linearity <sup>(2)</sup>	DNL	-2		2	count
10-bit integral non-linearity <sup>(2)</sup>	INL	-2		2	count
10-bit absolute error <sup>(3)</sup> 2, 4, 8, and 16 ATD sample clocks	AE	-2.5		2.5	count

Maximum source impedance	$R_S$		20	See note <sup>(4)</sup>	$K\Omega$
--------------------------	-------	--	----	-------------------------	-----------

1.  $V_{RH} - V_{RL} \geq 5.12V$ ;  $V_{DDA} - V_{SSA} = 5.12V$

2. At  $V_{REF} = 5.12V$ , one 8-bit count = 20 mV, and one 10-bit count = 5mV.

INL and DNL are characterized using the process window parameters affecting the ATD accuracy, but they are not tested.

3. These values include quantization error which is inherently 1/2 count for any A/D converter. Accuracy tested when when  $V_{RL}=V_{SS}$ ,  $V_{RH}=V_{DD}$  and external source impedance is close to zero.

4. Maximum source impedance is application-dependent. Error resulting from pin leakage depends on junction leakage into the pin and on leakage due to charge-sharing with internal capacitance.

Error from junction leakage is a function of external source impedance and input leakage current. Expected error in result value due to junction leakage is expressed in voltage ( $V_{ERRJ}$ ):

$$V_{ERRJ} = R_S \times I_{OFF}$$

where  $I_{OFF}$  is a function of operating temperature. Charge-sharing effects with internal capacitors are a function of ATD clock speed, the number of channels being scanned, and source impedance. For 8-bit conversions, charge pump leakage is computed as follows:

$$V_{ERRJ} = .25pF \times V_{DDA} \times R_S \times ATDCLK / (8 \times \text{number of channels})$$

**Table 20-7. ATD AC Characteristics (Operating)**

$V_{DD} = 5.0 \text{ Vdc} \pm 10\%$ ,  $V_{SS} = 0 \text{ Vdc}$ ,  $T_A = T_L \text{ to } T_H$ , ATD Clock = 2 MHz, unless otherwise noted

Characteristic	Symbol	Min	Max	Unit
MCU clock frequency (p-clock)	$f_{PCLK}$	2.0	8.0	MHz
ATD operating clock frequency	$f_{ATDCLK}$	0.5	2.0	MHz
ATD 8-Bit conversion period clock cycles <sup>(1)</sup> conversion time <sup>(2)</sup>	$n_{CONV8}$ $t_{CONV8}$	18 9	32 16	cycles $\mu\text{s}$
ATD 10-Bit conversion period clock cycles <sup>(1)</sup> conversion time <sup>(2)</sup>	$n_{CONV10}$ $t_{CONV10}$	20 10	34 17	cycles $\mu\text{s}$
Stop and ATD power up recovery time <sup>(3)</sup> $V_{DDA} = 5.0\text{V}$	$t_{SR}$		10	$\mu\text{s}$

1. The minimum time assumes a final sample period of 2 ATD clock cycles while the maximum time assumes a final sample period of 16ATD clocks.
2. This assumes an ATD clock frequency of 2.0MHz.
3. From the time ADPU is asserted until the time an ATD conversion can begin.

**Table 20-8. ATD Maximum Ratings**

Characteristic	Symbol	Value	Units
ATD reference voltage $V_{RH} \leq V_{DDA}$ $V_{RL} \geq V_{SSA}$	$V_{RH}$ $V_{RL}$	-0.3 to +6.5 -0.3 to +6.5	V V
$V_{SS}$ differential voltage	$ V_{SS} - V_{SSA} $	0.1	V
$V_{DD}$ differential voltage	$V_{DD} - V_{DDA}$ $V_{DDA} - V_{DD}$	6.5 0.3	V V
$V_{REF}$ differential voltage	$ V_{RH} - V_{RL} $	6.5	V
Reference to supply differential voltage	$ V_{RH} - V_{DDA} $	6.5	V

# Electrical Specifications

**Table 20-9. EEPROM Characteristics**

$V_{DD} = 5.0 \text{ Vdc} \pm 10\%$ ,  $V_{SS} = 0 \text{ Vdc}$ ,  $T_A = T_L$  to  $T_H$ , unless otherwise noted

Characteristic	Symbol	Min	Typical	Max	Unit
Minimum programming clock frequency <sup>(1)</sup>	$f_{\text{PROG}}$	1.0			MHz
Programming time	$t_{\text{PROG}}$	10		10.5	ms
Clock recovery time, following STOP, to continue programming	$t_{\text{CRSTOP}}$			$t_{\text{PROG}} + 1$	ms
Erase time	$t_{\text{ERASE}}$	10		10.5	ms
Write/erase endurance		10,000	30,000 <sup>(2)</sup>		cycles
Data retention		10			years

1. RC oscillator must be enabled if programming is desired and  $f_{\text{SYS}} < f_{\text{PROG}}$ .
2. If average  $T_H$  is below 85° C.

**Table 20-10. Flash EEPROM Characteristics (68HC912D60 only)**

$V_{DD} = 5.0 \text{ Vdc} \pm 10\%$ ,  $V_{SS} = 0 \text{ Vdc}$ ,  $T_A = T_L$  to  $T_H$ , unless otherwise noted

Characteristic	Symbol	Min	Typical	Max	Units
Program/erase supply voltage: Read only Program / erase / verify	$V_{\text{FP}}$	$V_{\text{DD}} - 0.35$ 11.4	$V_{\text{DD}}$ 12	$V_{\text{DD}} + 0.5$ 12.6	V V
Program/erase supply current Word program ( $V_{\text{FP}} = 12\text{V}$ ) Erase ( $V_{\text{FP}} = 12\text{V}$ )	$I_{\text{FP}}$			30 4	mA mA
Number of programming pulses	$n_{\text{PP}}$			50	pulses
Programming pulse	$t_{\text{PPULSE}}$	20		25	$\mu\text{s}$
Program to verify time	$t_{\text{VPROG}}$	10			$\mu\text{s}$
Program margin	$\rho_m$	100 <sup>(1)</sup>			%
Number of erase pulses	$n_{\text{EP}}$			5	pulses
Erase pulse	$t_{\text{EPULSE}}$	5		10	ms
Erase to verify time	$t_{\text{VERASE}}$	1			ms
Erase margin	$e_m$	100 <sup>(1)</sup>			%
Program/erase endurance		100			cycles
Data retention		10			years

1. The number of margin pulses required is the same as the number of pulses used to program or erase.

Use of an external circuit to condition  $V_{\text{FP}}$  is recommended. [Figure 20-1](#) shows a simple circuit that maintains required voltages and filters transients.  $V_{\text{FP}}$  is pulled to  $V_{\text{DD}}$  via Schottky diode D2. Application of

programming voltage via diode reverse-biases D2, protecting  $V_{DD}$  from excessive reverse current. D2 also protects the FLASH from damage should programming voltage go to 0. Programming power supply voltage must be adjusted to compensate for the forward-bias drop across D1. The charge time constant of R1 and C1 filters transients, while R2 provides a discharge bleed path to C1. Allow for RC charge and discharge time constants when applying and removing power. When using this circuit, keep leakage from external devices connected to the  $V_{FP}$  pin low, to minimize diode voltage drop.

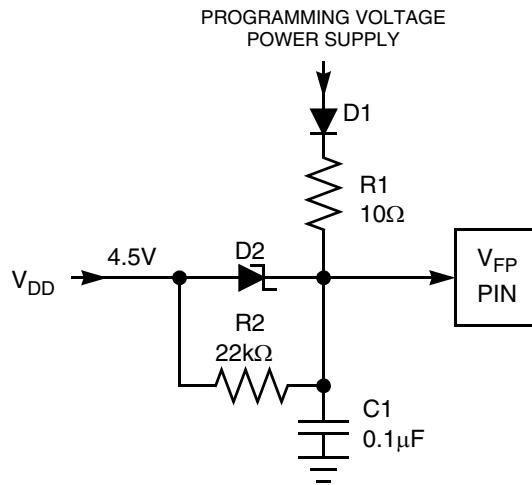


Figure 20-1  $V_{FP}$  Conditioning Circuit

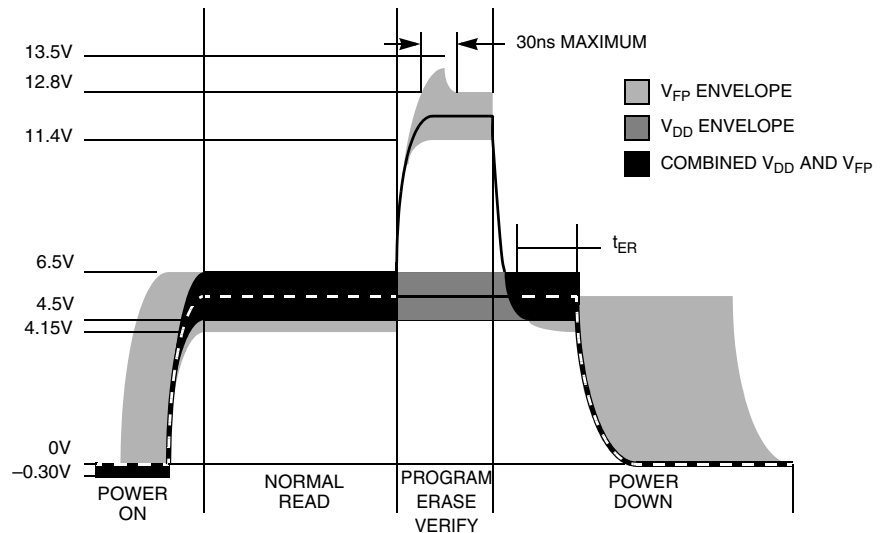


Figure 20-2  $V_{FP}$  Operating Range

# Electrical Specifications

**Table 20-11. Pulse Width Modulator Characteristics**

$V_{DD} = 5.0 \text{ Vdc} \pm 10\%$ ,  $V_{SS} = 0 \text{ Vdc}$ ,  $T_A = T_L$  to  $T_H$ , unless otherwise noted

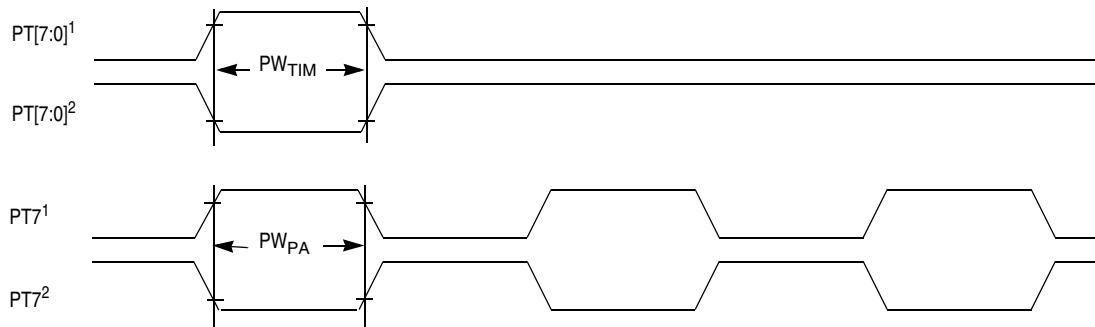
Characteristic	Symbol	Min	Max	Unit
E-clock frequency	$f_{\text{eclk}}$	0.004	8.0	MHz
A-clock frequency Selectable	$f_{\text{aclk}}$	$f_{\text{eclk}}/128$	$f_{\text{eclk}}$	Hz
B-clock frequency Selectable	$f_{\text{bclk}}$	$f_{\text{eclk}}/128$	$f_{\text{eclk}}$	Hz
Left-aligned PWM frequency 8-bit 16-bit	$f_{\text{lpwm}}$	$f_{\text{eclk}}/1\text{M}$ $f_{\text{eclk}}/256\text{M}$	$f_{\text{eclk}}/2$ $f_{\text{eclk}}/2$	Hz Hz
Left-aligned PWM resolution	$r_{\text{lpwm}}$	$f_{\text{eclk}}/4\text{K}$	$f_{\text{eclk}}$	Hz
Center-aligned PWM frequency 8-bit 16-bit	$f_{\text{cpwm}}$	$f_{\text{eclk}}/2\text{M}$ $f_{\text{eclk}}/512\text{M}$	$f_{\text{eclk}}$ $f_{\text{eclk}}$	Hz Hz
Center-aligned PWM resolution	$r_{\text{cpwm}}$	$f_{\text{eclk}}/4\text{K}$	$f_{\text{eclk}}$	Hz

**Table 20-12. Control Timing**

Characteristic	Symbol	8.0 MHz		Unit
		Min	Max	
Frequency of operation	$f_o$	0.004	8.0	MHz
E-clock period	$t_{\text{cyc}}$	0.125	250	$\mu\text{s}$
External oscillator frequency	$f_{\text{eo}}$	0.5	16.0 <sup>(1)</sup>	MHz
Processor control setup time $t_{\text{PCSU}} = t_{\text{cyc}}/2 + 20$	$t_{\text{PCSU}}$	82	—	ns
Reset input pulse width To guarantee external reset vector Minimum input time (can be preempted by internal reset)	$PW_{\text{RSTL}}$	32 2	— —	$t_{\text{cyc}}$ $t_{\text{cyc}}$
Mode programming setup time	$t_{\text{MPS}}$	4	—	$t_{\text{cyc}}$
Mode programming hold time	$t_{\text{MPH}}$	10	—	ns
Interrupt pulse width, $\overline{\text{IRQ}}$ edge-sensitive mode $PW_{\text{IRQ}} = 2t_{\text{cyc}} + 20$	$PW_{\text{IRQ}}$	270	—	ns
Wait recovery startup time	$t_{\text{WRS}}$	—	4	$t_{\text{cyc}}$
Timer input capture pulse width $PW_{\text{TIM}} = 2t_{\text{cyc}} + 20$	$PW_{\text{TIM}}$	270	—	ns

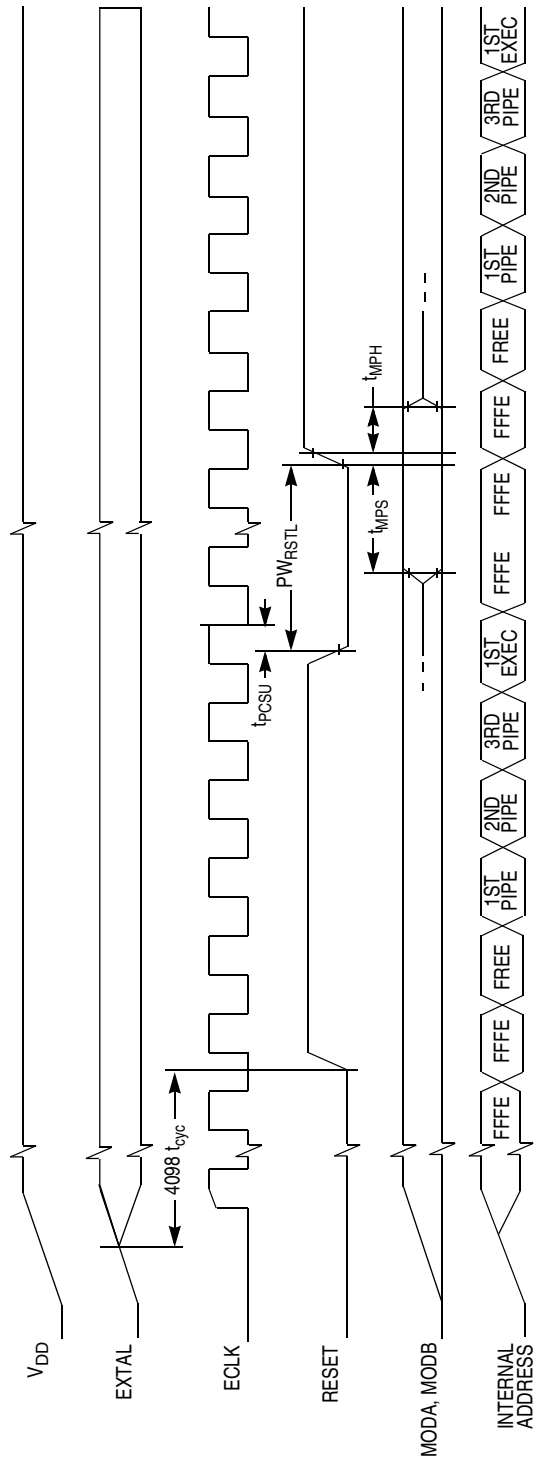
1. When using a quartz crystal, operation should be restricted to 8MHz.

**NOTE:**  $\overline{RESET}$  is recognized during the first clock cycle it is held low. Internal circuitry then drives the pin low for 16 clock cycles, releases the pin, and samples the pin level 8 cycles later to determine the source of the interrupt.



NOTES:  
1. Rising edge sensitive input  
2. Falling edge sensitive input

**Figure 20-3. Timer Inputs**



NOTE: Reset timing is subject to change.

Figure 20-4. POR and External Reset Timing Diagram



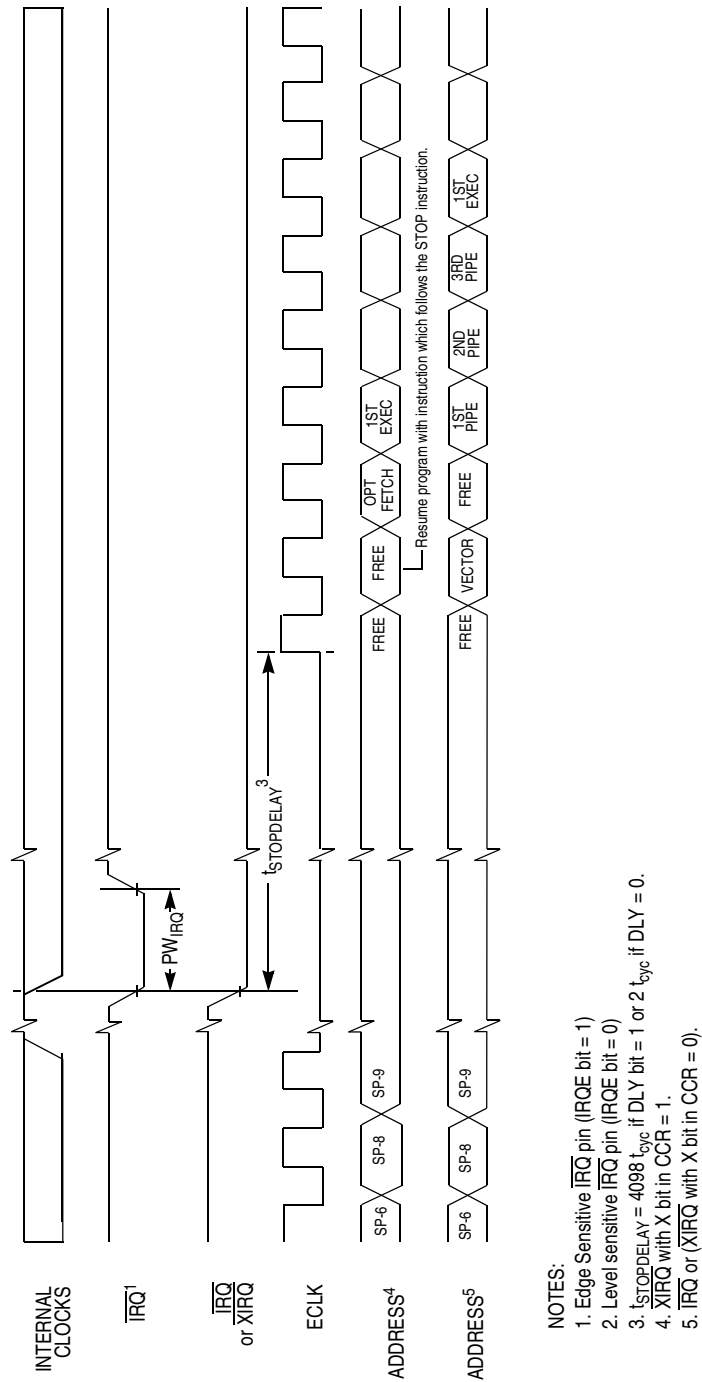
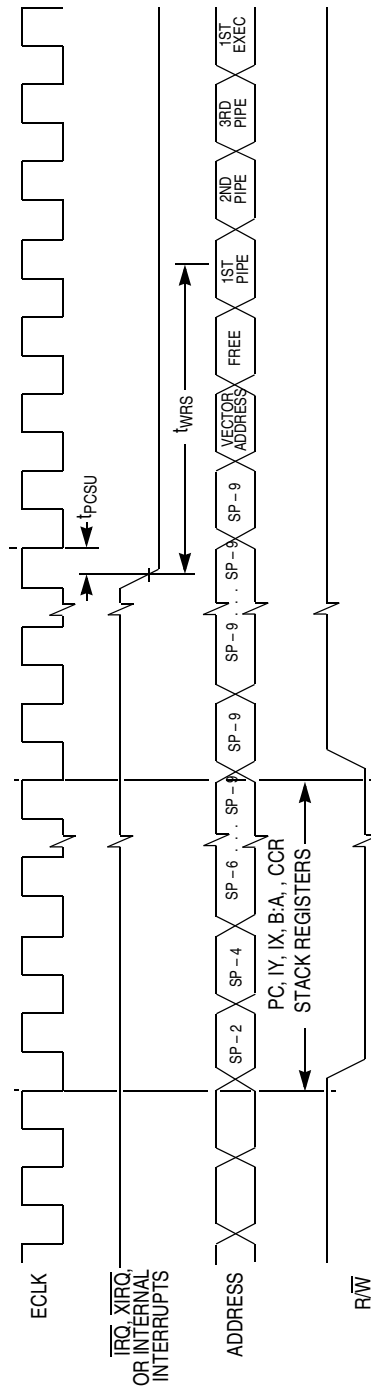


Figure 20-5. STOP Recovery Timing Diagram



NOTE:  $\overline{\text{RESET}}$  also causes recovery from WAIT.

Figure 20-6. WAIT Recovery Timing Diagram

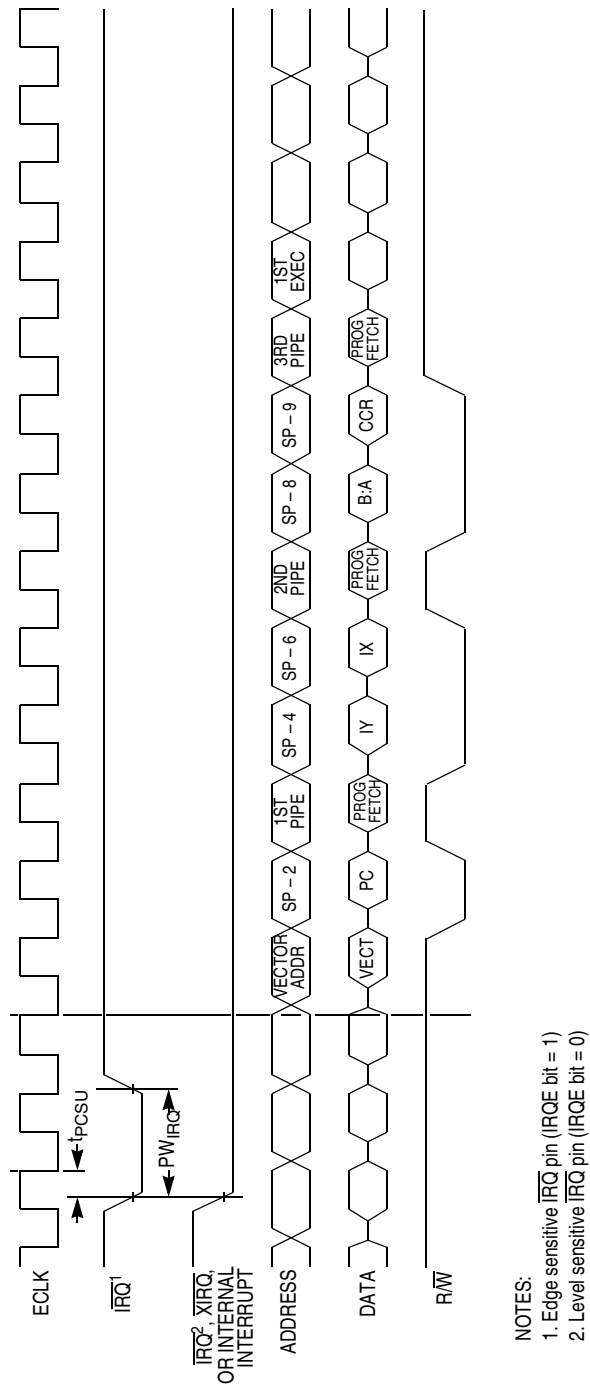
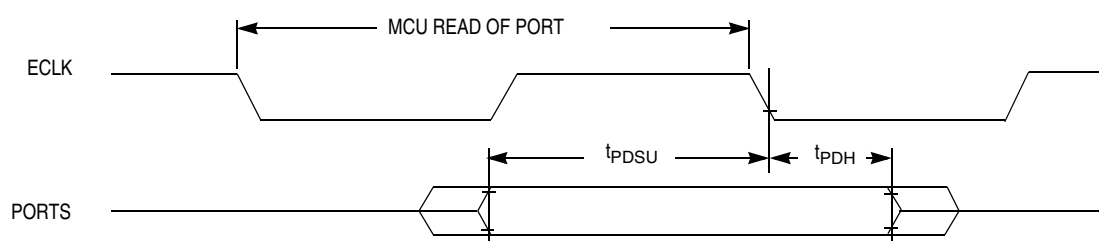


Figure 20-7. Interrupt Timing Diagram

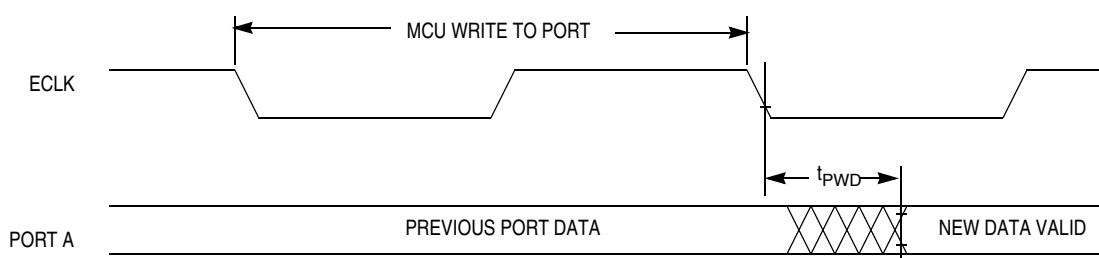
# Electrical Specifications

**Table 20-13. Peripheral Port Timing**

Characteristic	Symbol	8.0 MHz		Unit
		Min	Max	
Frequency of operation (E-clock frequency)	$f_o$	0.004	8.0	MHz
E-clock period	$t_{cyc}$	0.125	250	$\mu s$
Peripheral data setup time MCU read of port $t_{PDSU} = t_{cyc}/2 + 40$	$t_{PDSU}$	102	—	ns
Peripheral data hold time MCU read of ports	$t_{PDH}$	0	—	ns
Delay time, peripheral data write MCU write to ports except Port CAN	$t_{PWD}$	—	40	ns
Delay time, peripheral data write MCU write to Port CAN	$t_{PWD}$	—	71	ns



**Figure 20-8. Port Read Timing Diagram**



**Figure 20-9. Port Write Timing Diagram**

**Table 20-14. Multiplexed Expansion Bus Timing**

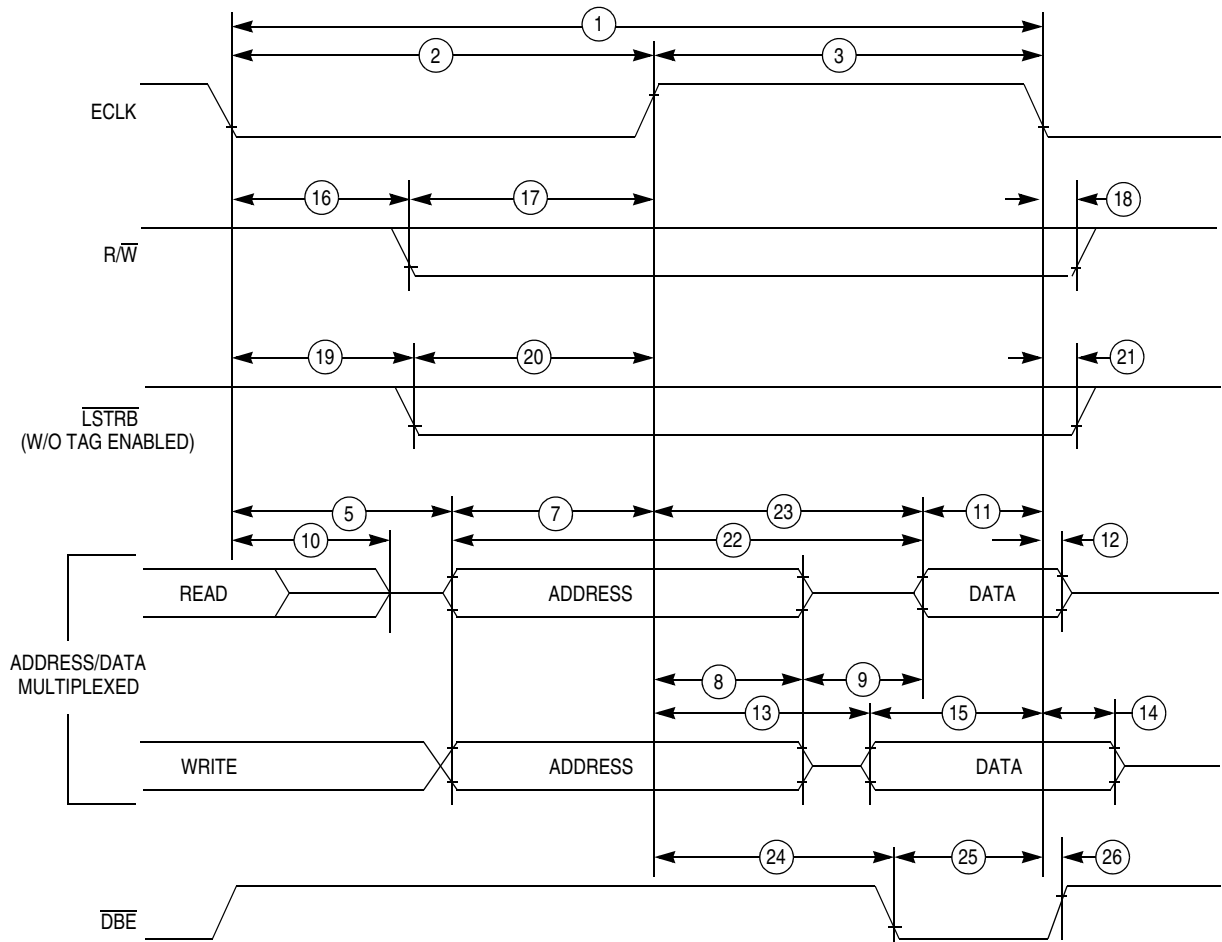
$V_{DD} = 5.0 \text{ Vdc} \pm 10\%$ ,  $V_{SS} = 0 \text{ Vdc}$ ,  $T_A = T_L$  to  $T_H$ , unless otherwise noted

Num	Characteristic <sup>(1), (2), (3), (4)</sup>	Delay	Symbol	8 MHz		2MHz		Unit
				Min	Max	Min	Max	
	Frequency of operation (E-clock frequency)		$f_o$	0.004	8.0	0.004	2.0	MHz
1	Cycle time $t_{cyc} = 1/f_o$	—	$t_{cyc}$	0.125	250	0.5	250	$\mu\text{s}$
2	Pulse width, E low $PW_{EL} = t_{cyc}/2 + \text{delay}$	-4	$PW_{EL}$	58		246		ns
3	Pulse width, E high <sup>(5)</sup> $PW_{EH} = t_{cyc}/2 + \text{delay}$	-2	$PW_{EH}$	60		248		ns
5	Address delay time $t_{AD} = t_{cyc}/4 + \text{delay}$	27	$t_{AD}$		58		152	ns
7	Address valid time to ECLK rise $t_{AV} = PW_{EL} - t_{AD}$	—	$t_{AV}$	0		94		ns
8	Multiplexed address hold time $t_{MAH} = t_{cyc}/4 + \text{delay}$	-18	$t_{MAH}$	13		107		ns
9	Address Hold to Data Valid	—	$t_{AHDS}$	20		20		ns
10	Data Hold to High Z $t_{DHZ} = t_{AD} - 20$	—	$t_{DHZ}$		38		132	ns
11	Read data setup time	—	$t_{DSR}$	25		25		ns
12	Read data hold time	—	$t_{DHR}$	0		0		ns
13	Write data delay time	—	$t_{DDW}$		47		165	ns
14	Write data hold time	—	$t_{DHW}$	20		20		ns
15	Write data setup time <sup>(5)</sup> $t_{DSW} = PW_{EH} - t_{DDW}$	—	$t_{DSW}$	13		83		ns
16	Read/write delay time $t_{RWD} = t_{cyc}/4 + \text{delay}$	18	$t_{RWD}$		49		143	ns
17	Read/write valid time to E rise $t_{RWV} = PW_{EL} - t_{RWD}$	—	$t_{RWV}$	9		103		ns
18	Read/write hold time	—	$t_{RWH}$	20		20		ns
19	Low strobe <sup>(6)</sup> delay time $t_{LSD} = t_{cyc}/4 + \text{delay}$	18	$t_{LSD}$		49		143	ns
20	Low strobe <sup>(6)</sup> valid time to E rise $t_{LSV} = PW_{EL} - t_{LSD}$	—	$t_{LSV}$	9		103		ns
21	Low strobe <sup>(6)</sup> hold time	—	$t_{LSH}$	20		20		ns
22	Address access time <sup>(5)</sup> $t_{ACCA} = t_{cyc} - t_{AD} - t_{DSR}$	—	$t_{ACCA}$		42		323	ns
23	Access time from E rise <sup>(5)</sup> $t_{ACCE} = PW_{EH} - t_{DSR}$	—	$t_{ACCE}$		35		223	ns
24	$\overline{DBE}$ delay from ECLK rise <sup>(5)</sup> $t_{DBED} = t_{cyc}/4 + \text{delay}$	8	$t_{DBED}$		39		133	ns
25	$\overline{DBE}$ valid time $t_{DBE} = PW_{EH} - t_{DBED}$	—	$t_{DBE}$	21		115		ns
26	$\overline{DBE}$ hold time from ECLK fall		$t_{DBEH}$	-3	10	-3	10	ns

1. All timings are calculated for normal port drives.
2. Crystal input is required to be within 45% to 55% duty.
3. Reduced drive must be off to meet these timings.
4. Unequalled loading of pins will affect relative timing numbers.

# Electrical Specifications

- 5. This characteristic is affected by clock stretch.  
Add  $N \times t_{cyc}$  where  $N = 0, 1, 2,$  or  $3,$  depending on the number of clock stretches.
- 6. Without TAG enabled.



NOTE: Measurement points shown are 20% and 70% of  $V_{DD}$

**Figure 20-10. Multiplexed Expansion Bus Timing Diagram**

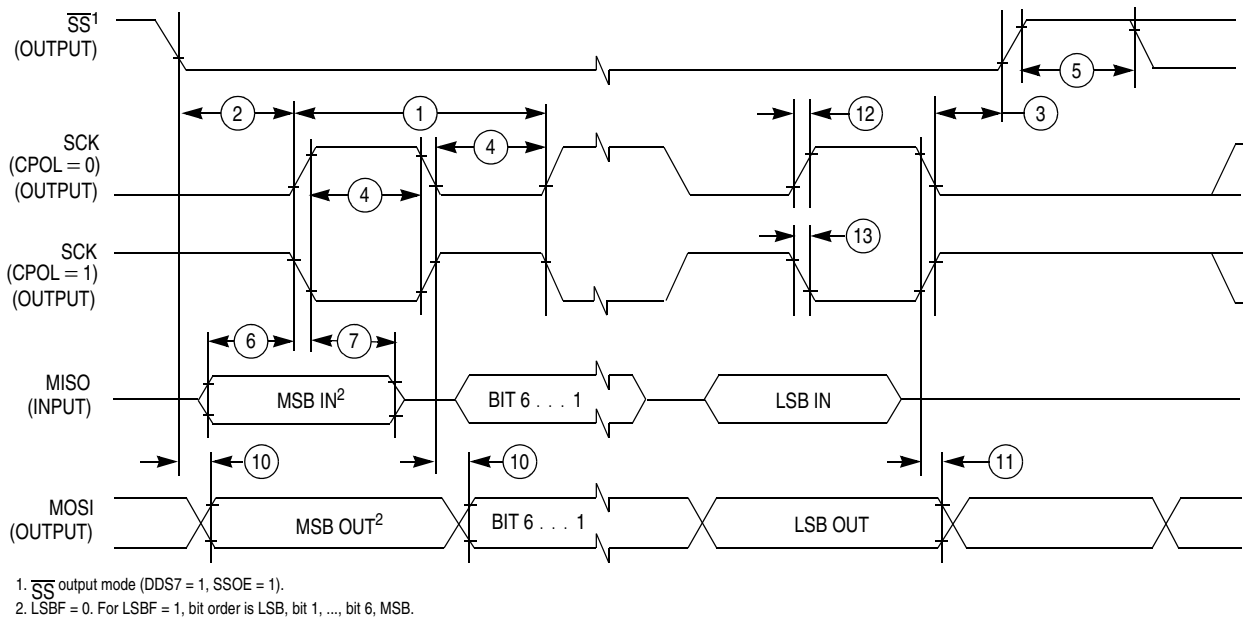
**Table 20-15. SPI Timing**

( $V_{DD} = 5.0 \text{ Vdc} \pm 10\%$ ,  $V_{SS} = 0 \text{ Vdc}$ ,  $T_A = T_L$  to  $T_H$ , 200 pF load on all SPI pins)<sup>(1)</sup>

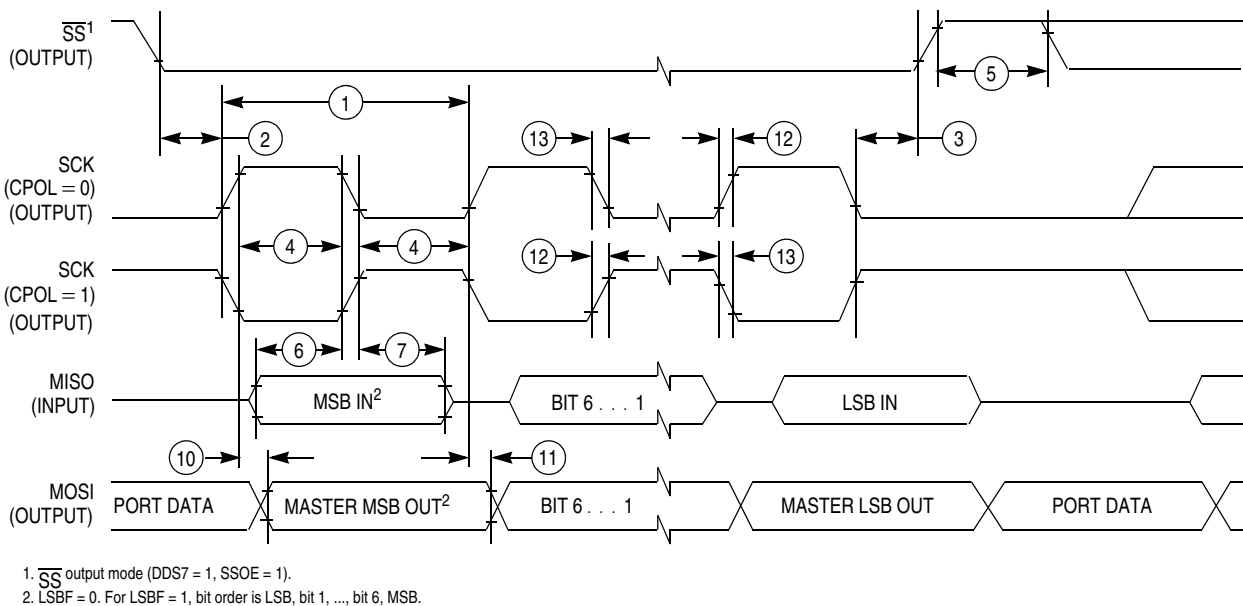
Num	Function	Symbol	Min	Max	Unit
	Operating Frequency Master Slave	$f_{op}$	1/256 1/256	1/2 1/2	$f_{eclk}$
1	SCK Period Master Slave	$t_{sck}$	2 2	256 —	$t_{cyc}$ $t_{cyc}$
2	Enable Lead Time Master Slave	$t_{lead}$	1/2 1	— —	$t_{sck}$ $t_{cyc}$
3	Enable Lag Time Master Slave	$t_{lag}$	1/2 1	— —	$t_{sck}$ $t_{cyc}$
4	Clock (SCK) High or Low Time Master Slave	$t_{wsck}$	$t_{cyc} - 30$ $t_{cyc} - 30$	128 $t_{cyc}$ —	ns ns
5	Sequential Transfer Delay Master Slave	$t_{td}$	1/2 1	— —	$t_{sck}$ $t_{cyc}$
6	Data Setup Time (Inputs) Master Slave	$t_{su}$	30 30	— —	ns ns
7	Data Hold Time (Inputs) Master Slave	$t_{hi}$	0 30	— —	ns ns
8	Slave Access Time	$t_a$	—	1	$t_{cyc}$
9	Slave MISO Disable Time	$t_{dis}$	—	1	$t_{cyc}$
10	Data Valid (after SCK Edge) Master Slave	$t_v$	— —	50 50	ns ns
11	Data Hold Time (Outputs) Master Slave	$t_{ho}$	0 0	— —	ns ns
12	Rise Time Input Output	$t_{ri}$ $t_{ro}$	— —	$t_{cyc} - 30$ 30	ns ns
13	Fall Time Input Output	$t_{fi}$ $t_{fo}$	— —	$t_{cyc} - 30$ 30	ns ns

1. All AC timing is shown with respect to 20%  $V_{DD}$  and 70%  $V_{DD}$  levels unless otherwise noted.

# Electrical Specifications



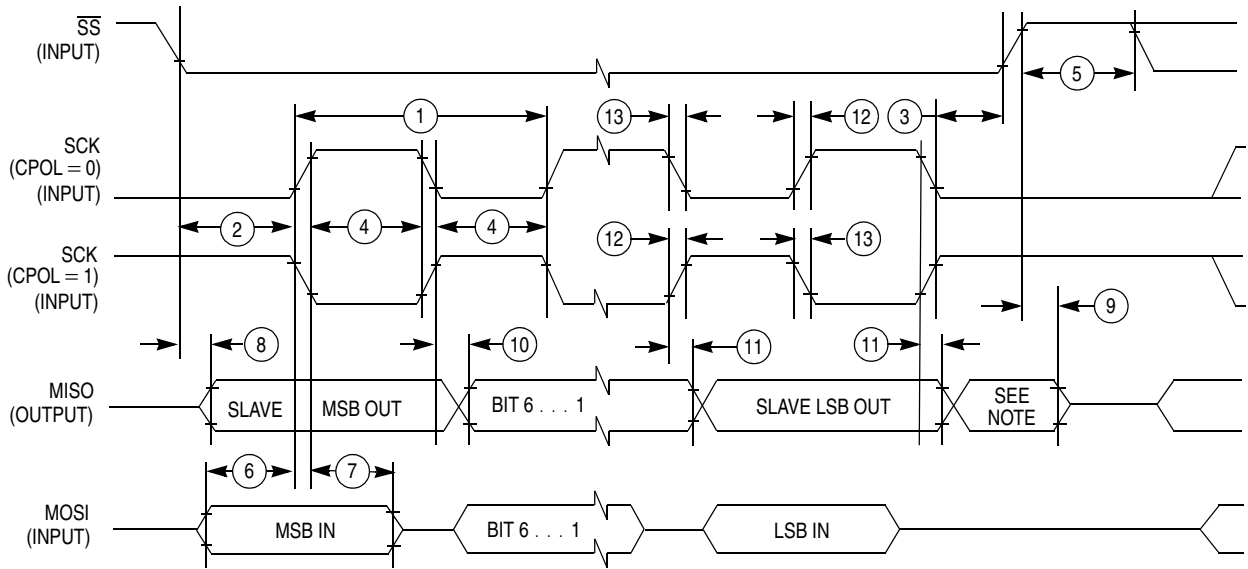
## A) SPI Master Timing (CPHA = 0)



## B) SPI Master Timing (CPHA = 1)

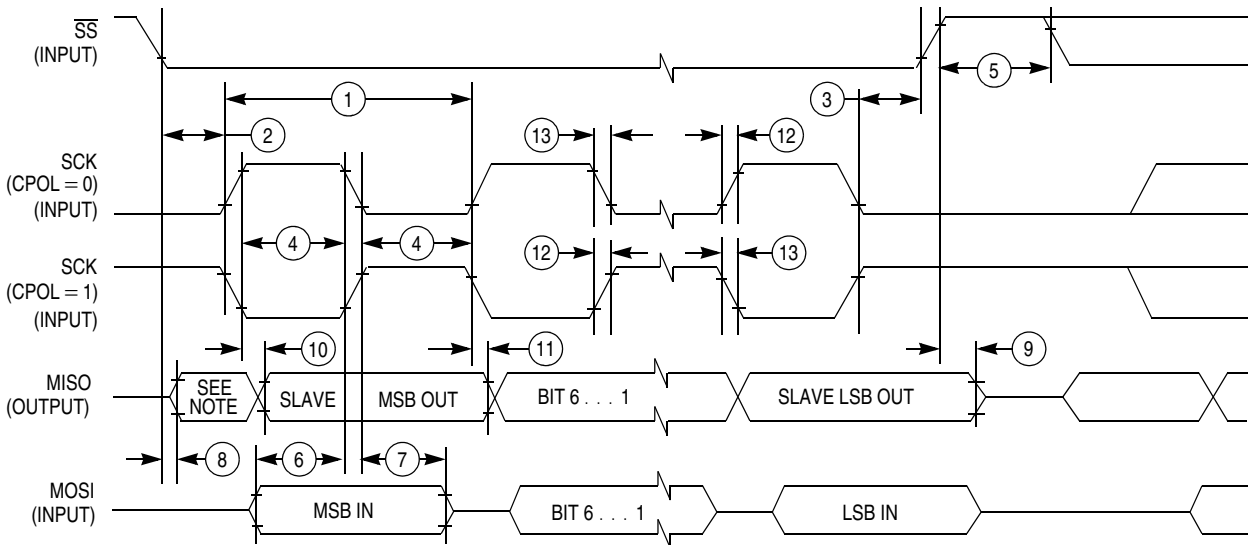
Figure 20-11. SPI Timing Diagram (1 of 2)





NOTE: Not defined but normally MSB of character just received.

### A) SPI Slave Timing (CPHA = 0)



NOTE: Not defined but normally LSB of character just received.

### B) SPI Slave Timing (CPHA = 1)

Figure 20-12. SPI Timing Diagram (2 of 2)

# Electrical Specifications

**Table 20-16. CGM Characteristics**

5.0 Volts  $\pm 10\%$

Characteristic	Symbol	Min.	Typ.	Max.	Unit
PLL reference frequency, crystal oscillator range	$f_{REF}$	0.5		8	MHz
Bus frequency	$f_{BUS}$	0.004		8	MHz
VCO range	$f_{VCO}$	2.5		8	MHz
VCO Limp-Home frequency	$f_{VCOMIN}$	0.5	1	2.5	MHz
Lock Detector transition from Acquisition to Tracking mode <sup>(1)</sup>	$\Delta_{trk}$	3%		4%	—
Lock Detection	$\Delta_{Lock}$	0%		1.5%	—
Un-Lock Detection	$\Delta_{unl}$	0.5%		2.5%	—
Lock Detector transition from Tracking to Acquisition mode <sup>(1)</sup>	$\Delta_{unt}$	6%		8%	—
Minimum leakage resistance on crystal oscillator pins	$r_{leak}$	1			M $\Omega$
PLL Stabilization delay <sup>(2)</sup>					
PLL Total Stabilization Delay <sup>(3)</sup>	$t_{stab}$		3		ms
PLLON Acquisition mode stabilization delay. <sup>(3)</sup>	$t_{acq}$		1		ms
PLLON tracking mode stabilization delay. <sup>(3)</sup>	$t_{al}$		2		ms

1. AUTO bit set

2. PLL stabilization delay is highly dependent on operational requirement and external component values (i.e. crystal, XFC filter component values). Note (3) shows typical delay values for a typical configuration. Appropriate XFC filter values should be chosen based on operational requirement of system.

3.  $f_{REF} = 4\text{MHz}$ ,  $f_{BUS} = 8\text{MHz}$  (REFDV = # $\$00$ , SYNRR = # $\$01$ ), XFC:Cs = 33nF, Cp = 3.3nF, Rs = 2.7K $\Omega$ .

**Table 20-17. Key Wake-up**

$V_{DD} = 5.0\text{V dc} \pm 10\%$

Characteristic	Symbol	Min.	Max.	Unit
STOP Key Wake-Up Filter time	$t_{KWSTP}$	2	10	$\mu\text{s}$
Key Wake-Up Single Pulse Time Interval	$t_{KWSP}$	20		$\mu\text{s}$

**Table 20-18. msCAN12 Wake-up Time from Sleep Mode**

$V_{DD} = 5.0\text{V dc} \pm 10\%$ ,  $V_{SS} = 0\text{Vdc}$ ,  $T_A = T_L$  to  $T_H$ , unless otherwise noted

Characteristic	Symbol	Min.	Max.	Unit
Wake-Up time	$t_{wup}$	2	5	$\mu\text{s}$

## Section 21. Appendix: CGM Practical Aspects

### 21.1 Contents

21.2	Introduction . . . . .	387
21.3	A Few Hints For The CGM Crystal Oscillator Application. . . . .	387
21.4	Practical Aspects For The PLL Usage . . . . .	390
21.5	Printed Circuit Board Guidelines. . . . .	395

### 21.2 Introduction

This sections provides useful and practical pieces of information concerning the implementation of the CGM module.

### 21.3 A Few Hints For The CGM Crystal Oscillator Application

#### 21.3.1 What Loading Capacitors To Choose?

First, from small-signal analysis, it is known that relatively large values for C1 and C2 have a positive impact on the phase margin. However, the higher loading they represent decreases the loop gain. Alternatively, small values for these capacitors will lead to higher open loop gain, but as the frequency of oscillation approaches the parallel resonance, the phase margin, and consequently the ability to start-up correctly, will decrease. From this it is clear that relatively large capacitor values (>33pF), are reserved for low frequency crystals in the MHz range.

**NOTE:** *Using the recommended loading capacitor CL value from the crystal manufacturer is a good starting point. Taking into account unavoidable strays, this equates to about (CL-2pF).*

Theoretically speaking, nothing precludes the use of non-identical values for C1 and C2. As this complicate a bit the management of the final board device list, this is not recommended. However, if asymmetrical capacitors are chosen, the value of C1 should be higher than C2 (because the reflected loading is proportional to the square of the impedance of C2).

### 21.3.2 DC Bias

Due to the nature of the translated ground Colpitts oscillator a DC voltage bias is applied to the crystal.

Please contact the crystal manufacturer for specific DC bias conditions and recommended capacitance value (if applicable).

### 21.3.3 What Is the Final Oscillation Frequency?

The exact calculation is not straightforward as it takes into account the resonator characteristics and the loading capacitors values as well as internal design parameters which can vary with Process Voltage Temperature (PVT) conditions. Nevertheless, if L is the series inductance, R is the series resistance, C is the series capacitance and Cc the parallel capacitance of the crystal, we can then use the following simplified equation:

$$F_{osc} = \frac{1}{2\pi} \cdot \sqrt{\frac{1}{LC} + \frac{1}{L \cdot (C_c + C1 \parallel C2)}}$$

C1=C2=C1 yields to

$$F_{osc} = \frac{1}{2\pi} \cdot \sqrt{\frac{1}{LC} + \frac{1}{L \cdot (C_c + C1/2)}}$$

### 21.3.4 How Do I Control The Peak to Peak Oscillation Amplitude?

The CGM oscillator is equipped with an Amplitude Limitation Control loop which integrates the peak to peak 'extal' amplitude and in return reduces the steady current of the transconductor device until a stable

quiescent point is reached. Controlling this final peak to peak amplitude can be performed by three means:

1. Reducing the values of C1 and C2. This decreases the loading so that the necessary gm value required to sustain oscillation can be smaller. The consequently smaller current will be reached with a larger 'extal' swing.
2. Using VDDPLL=VSS (i.e. shutting off the PLL). Doing so increases the starting current by approximately 50%. All other parameters staying the same, a larger 'extal' swing will be required to reduce this starting current to its quiescent value.
3. Also, placing a high value resistor (>1M $\Omega$ ) across the EXTAL and XTAL pins significantly increased the oscillation amplitude. Because this complicates the design analysis as it transforms a pure susceptance  $j\omega C1$  into a complex admittance  $G+j\omega C1$ , Motorola cannot promote this application trick.

### 21.3.5 What Do I Do In Case The Oscillator Does Not Start-up?

1. First, verify that the application schematic respects the principle of operation, i.e. crystal mounted between EXTAL and VSS, Capacitor C1 between XTAL and EXTAL, Capacitor C2 between XTAL and VSS, nothing else. This is not the conventional MCU application schematic of the Pierce oscillator as it can be seen on other HC12 derivatives!
2. Re-consider the choice of the tuning capacitors.
3. The oscillator circuitry is powered internally from a core VDD pad and the return path is the VSSPLL pad. Verify on the application PCB the correct connection of these pads (especially VSSPLL), but also verify the waveform of the VDD voltage as it is imposed on the pad. Sometimes external components (for instance choke inductors), can cause oscillations on the power line. This is of course detrimental to the oscillator circuitry.
4. If possible, consider using a resonator with built-in tuning capacitors. They may offer better performances with respect to their discrete elements implementation.

### 21.4 Practical Aspects For The PLL Usage

#### 21.4.1 Synthesized Bus Frequency

Starting from a ceramic resonator or quartz crystal frequency  $F_{XTAL}$ , if 'refdv' and 'synr' are the decimal content of the REFDV and SYNCR registers respectively, then the MCU bus frequency will simply be:

$$F_{BUS} = F_{VCO} = \frac{F_{XTAL} \cdot (\text{synr} + 1)}{(\text{refdv} + 1)}$$

$$\text{synr} \in \{0,1,2,3\dots63\}$$

$$\text{refdv} \in \{0,1,2,3\dots7\}$$

**NOTE:** *It is not allowed to synthesize a bus frequency that is lower than the crystal frequency, as the correct functioning of some internal synchronizers would be jeopardized (e.g. the MCLK and XCLK clock generators).*

#### 21.4.2 Operation Under Adverse Environmental Conditions

The normal operation for the PLL is the so-called 'automatic bandwidth selection mode' which is obtained by having the AUTO bit set in the PLLCR register. When this mode is selected and as the VCO frequency approaches its target, the charge pump current level will automatically switch from a relatively high value of around 40  $\mu\text{A}$  to a lower value of about 3  $\mu\text{A}$ . It can happen that this low level of charge pump current is not enough to overcome leakages present at the XFC pin due to adverse environmental conditions. These conditions are frequently encountered for uncoated PCBs in automotive applications. The main symptom for this failure is an unstable characteristic of the PLL which in fact 'hunts' between acquisition and tracking modes. It is then advised for the running software to place the PLL in manual, forced acquisition mode by clearing both the AUTO and the  $\overline{ACQ}$  bits in the PLLCR register. Doing so will maintain the high current level in the charge pump constantly and will permit to sustain higher levels of leakages at the XFC pin. This latest revision of the Clock Generator Module maintains the lock detection

feature even in manual bandwidth control, offering then to the application software the same flexibility for the clocking control as the automatic mode.

### 21.4.3 Filter Components Selection Guide

#### 21.4.3.1 Equations Set

These equations can be used to select a set of filter components. Two cases are considered:

1. The 'tracking' mode. This situation is reached normally when the PLL operates in automatic bandwidth selection mode (AUTO=1 in the PLLCR register).
2. The 'acquisition' mode. This situation is reached when the PLL operates in manual bandwidth selection mode and forced acquisition (AUTO=0,  $\overline{ACQ}$ =0 in the PLLCR register).

In both equations, the power supply should be 5V. Start with the target loop bandwidth as a function of the other parameters, but obviously, nothing prevents the user from starting with the capacitor value for example. Also, remember that the smoothing capacitor is always assumed to be one tenth of the series capacitance value.

So with:

- m: the multiplying factor for the reference frequency (i.e. (synr+1))
- R: the series resistance of the low pass filter in  $\Omega$
- C: the series capacitance of the low pass filter in nF
- F<sub>bus</sub>: the target bus frequency expressed in MHz
- $\zeta$ : the desired damping factor
- F<sub>c</sub>: the desired loop bandwidth expressed in Hz

for the 'tracking' mode:

$$F_c = \frac{2 \cdot 10^9 \cdot \zeta^2}{\pi \cdot R \cdot C} = \frac{37.78 \cdot e^{\left(\frac{1.675 - F_{bus}}{10.795}\right)} \cdot R}{2 \cdot \pi \cdot m}$$

and for the ‘acquisition’ mode:

$$F_c = \frac{2 \cdot 10^9 \cdot \zeta^2}{\pi \cdot R \cdot C} = \frac{415.61 \cdot e^{\left(\frac{1.675 - F_{bus}}{10.795}\right)} \cdot R}{2 \cdot \pi \cdot m}$$

### 21.4.3.2 Particular Case of an 8MHz Synthesis

Assume that a desired value for the damping factor of the second order system is close to 0.9 as this leads to a satisfactory transient response. Then, derived from the equations above, [Table 21-1](#) and [Table 21-2](#) suggest sets of values corresponding to several loop bandwidth possibilities in the case of an 8MHz synthesis for the two cases mentioned above.

The filter components values are chosen from standard series (e.g. E12 for resistors). The operating voltage is assumed to be 5V (although there is only a minor difference between 3V and 5V operation). The smoothing capacitor  $C_p$  in parallel with  $R_0$  and  $C_0$  is set to be 1/10 of the value of  $C_0$ . The reference frequencies mentioned in this table correspond to the output of the fine granularity divider controlled by the REFDV register. This means that the calculations are irrespective of the way the reference frequency is generated (directly for the crystal oscillator or after division). The target frequency value also has an influence on the calculations of the filter components because the VCO gain is NOT constant over its operating range.

The bandwidth limit corresponds to the so-called Gardner’s criteria. It corresponds to the maximum value that can be chosen before the continuous time approximation ceases to be justified. It is of course advisable to stay far away from this limit.



**Table 21-1. Suggested 8MHz Synthesis PLL Filter Elements (Tracking Mode)**

Reference [MHz]	SYNR	Fbus [MHz]	C <sub>0</sub> [nF]	R <sub>0</sub> [kΩ]	C <sub>p</sub> [nF]	Loop Bandwidth [kHz]	Bandwidth Limit [kHz]
0.614	\$0C	7.98	100	4.3	10	1.1	157
0.614	\$0C	7.98	4.7	20	0.47	5.3	157
0.614	\$0C	7.98	1.0	43	0.1	11.5	157
0.614	\$0C	7.98	0.33	75	0.033	20	157
0.8	\$09	8.00	220	2.7	22	0.9	201
0.8	\$09	8.00	10	12	1.0	4.2	201
0.8	\$09	8.00	2.2	27	0.22	8.6	201
0.8	\$09	8.00	0.47	56	0.047	19.2	201
1	\$07	8.00	220	2.4	22	1	251
1	\$07	8.00	10	11	1.0	4.7	251
1	\$07	8.00	2.2	24	0.22	9.9	251
1	\$07	8.00	0.47	51	0.047	21.4	251
1.6	\$05	8.00	330	1.5	33	1	402
1.6	\$05	8.00	10	9.1	1.0	5.9	402
1.6	\$05	8.00	3.3	15	0.33	10.2	402
1.6	\$05	8.00	1.0	27	0.1	18.6	402
2	\$03	8.00	470	1.1	47	0.96	502
2	\$03	8.00	22	5.1	2.2	4.4	502
2	\$03	8.00	4.7	11	0.47	9.6	502
2	\$03	8.00	1.0	24	0.1	20.8	502
2.66	\$02	8.00	220	1.5	22	1.6	668
2.66	\$02	8.00	22	4.7	2.2	5.1	668
2.66	\$02	8.00	4.7	10	0.47	11	668
2.66	\$02	8.00	1.0	22	0.1	24	668
4	\$01	8.00	220	1.2	22	1.98	1005
4	\$01	8.00	33	3	3.3	5.1	1005
4	\$01	8.00	10	5.6	1.0	9.3	1005
4	\$01	8.00	2.2	12	0.22	19.8	1005

**Table 21-2. Suggested 8MHz Synthesis PLL Filter Elements (Acquisition Mode)**

Reference [MHz]	SYNR	Fbus [MHz]	C <sub>0</sub> [nF]	R <sub>0</sub> [kΩ]	C <sub>p</sub> [nF]	Loop Bandwidth [kHz]	Bandwidth Limit [kHz]
0.614	\$0C	7.98	1000	0.43	100	1.2	157
0.614	\$0C	7.98	47	2	4.7	5.5	157
0.614	\$0C	7.98	10	4.3	1.0	12	157
0.614	\$0C	7.98	3.3	7.5	0.33	21	157
0.8	\$09	8.00	2200	0.27	220	0.9	201
0.8	\$09	8.00	100	1.2	10	4.4	201
0.8	\$09	8.00	22	2.4	2.2	9.3	201
0.8	\$09	8.00	4.7	5.6	0.47	20.1	201
1	\$07	8.00	2200	0.22	220	1	251
1	\$07	8.00	100	1.0	10	4.8	251
1	\$07	8.00	2.	2.2	2.2	10.4	251
1	\$07	8.00	4.7	4.7	0.47	22.5	251
1.6	\$05	8.00	3300	0.15	330	1.1	402
1.6	\$05	8.00	100	0.82	10	6.2	402
1.6	\$05	8.00	33	1.5	3.3	10.7	402
1.6	\$05	8.00	10	2.7	1.0	19.5	402
2	\$03	8.00	4700	0.1	470	1	502
2	\$03	8.00	220	0.51	22	4.6	502
2	\$03	8.00	47	1.0	4.7	10	502
2	\$03	8.00	10	2.4	1.0	21.8	502
2.66	\$02	8.00	2200	0.12	220	1.7	668
2.66	\$02	8.00	220	0.43	22	5.3	668
2.66	\$02	8.00	47	1.0	4.7	11.6	668
2.66	\$02	8.00	10	2	1.0	25.1	668
4	\$01	8.00	2200	0.1	220	2.1	1005
4	\$01	8.00	330	0.27	33	5.4	1005
4	\$01	8.00	100	0.51	10	9.7	1005
4	\$01	8.00	22	1.0	2.2	20.8	1005

## 21.5 Printed Circuit Board Guidelines

Printed Circuit Boards (PCBs) are the board of choice for volume applications. If designed correctly, a very low noise system can be built on a PCB with consequently good EMI/EMC performances. If designed incorrectly, PCBs can be extremely noisy and sensitive modules, and the CGM could be disrupted. Some common sense rules can be used to prevent such problems.

- Use a 'star' style power routing plan as opposed to a 'daisy chain'. Route power and ground from a central location to each chip individually, and use the widest trace practical (the more the chip draws current, the wider the trace). NEVER place the MCU at the end of a long string of serially connected chips.
- When using PCB layout software, first direct the routing of the power supply lines as well as the CGM wires (crystal oscillator and PLL). Layout constraints must be then reported on the other signals and not on these 'hot' nodes. Optimizing the 'hot' nodes at the end of the routing process usually gives bad results.
- Avoid notches in power traces. These notches not only add resistance (and are not usually accounted for in simulations), but they can also add unnecessary transmission line effects.
- Avoid ground and power loops. This has been one of the most violated guidelines of PCB layout. Loops are excellent noise transmitters and can be easily avoided. When using multiple layer PCBs, the power and ground plane concept works well but only when strictly adhered to (do not compromise the ground plane by cutting a hole in it and running signals on the ground plane layer). Keep the spacing around via holes to a minimum (but not so small as to add capacitive effects).
- Be aware of the three dimensional capacitive effects of multi-layered PCBs.
- Bypass (decouple) the power supplies of all chips as close to the chip as possible. Use one decoupling capacitor per power supply pair (VDD/VSS, VDDX/VSSX...). Two capacitors with a ratio of about 100 sometimes offer better performances over a broader

spectrum. This is especially the case for the power supply pins close to the E port, when the E clock and/or the calibration clock are used.

- On the general VDD power supply input, a 'T' low pass filter LCL can be used (e.g.  $10\mu\text{H}$ - $47\mu\text{F}$ - $10\mu\text{H}$ ). The 'T' is preferable to the 'II' version as the exhibited impedance is more constant with respect to the VDD current. Like many modular micro controllers, HC12 devices have a power consumption which not only varies with clock edges but also with the functioning modes.
- Keep high speed clock and bus trace length to a minimum. The higher the clock speed, the shorter the trace length. If noisy signals are sent over long tracks, impedance adjustments should be considered at both ends of the line (generally, simple resistors suffice).
- Bus drivers like the CAN physical interface should be installed close to their connector, with dedicated filtering on their power supply.
- Mount components as close to the board as possible. Snip excess lead length as close to the board as possible. Preferably use Surface Mount Devices (SMDs).
- Mount discrete components as close to the chip that uses them as possible.
- Do not cross sensitive signals ON ANY LAYER. If a sensitive signal must be crossed by another signal, do it as many layers away as possible and at right angles.
- Always keep PCBs clean. Solder flux, oils from fingerprints, humidity and general dirt can conduct electricity. Sensitive circuits can easily be disrupted by small amounts of leakage.
- Choose PCB coatings with care. Certain epoxies, paints, gelatins, plastics and waxes can conduct electricity. If the manufacturer cannot provide the electrical characteristics of the substance, do not use it.

In addition to the above general pieces of advice, the following guidelines should be followed for the CGM pins (but also more generally for any sensitive analog circuitry):

- Parasitic capacitance on EXTAL is absolutely critical – probably the most critical layout consideration. The XTAL pin is not as sensitive. All routing from the EXTAL pin through the resonator and the blocking cap to the actual connection to VSS must be considered.
- For minimum capacitance there should ideally be no ground / power plane around the EXTAL pin and associated routing. However, practical EMC considerations obviously should be taken into consideration for each application.
- The clock input circuitry is sensitive to noise so excellent supply routing and decoupling is mandatory. Connect the ground point of the oscillator circuit directly to the VSSPLL pin.
- Good isolation of PLL / Oscillator Power supply is critical. Use 1nF+ 100nF and keep tracks as low impedance as possible
- Load capacitors should be low leakage and stable across temperature – use NPO or C0G types.
- The load capacitors may ‘pull’ the target frequency by a few ppm. Crystal manufacturer specs show symmetrical values but the series device capacitance on EXTAL and XTAL are not symmetrical. It may be possible to adjust this by changing the values of the load capacitors – start-up conditions should be evaluated.
- Keep the adjacent Port H / Port E and RESET signals noise free. Don’t connect these to external signals and / or add series filtering – a series resistor is probably adequate.
- Any DC-blocking capacitor should be as low ESR as possible – for the range of crystals we are looking at anything over 1 Ohm is too much.
- Mount oscillator components on MCU side of board – avoid using vias in the oscillator circuitry.

## Appendix: CGM Practical Aspects

- Mount the PLL filter and oscillator components as close to the MCU as possible.
- Do not allow the EXTAL and XTAL signals to interfere with the XFC node. Keep these tracks as short as possible.
- Do not cross the CGM signals with any other signal on any level.
- Remember that the reference voltage for the XFC filter is VDDPLL.
- As the return path for the oscillator circuitry is VSSPLL, it is extremely important to CONNECT VSSPLL to VSS even if the PLL is not to be powered. Surface mount components reduce the susceptibility of signal contamination.
- Ceramic resonators with built-in capacitors are available. This is an interesting solution because the parasitic components involved are minimized due to the close proximity of the resonating elements.

## Section 22. Appendix: 68HC912D60A Flash EEPROM

### 22.1 Contents

22.2	Introduction . . . . .	399
22.3	Overview . . . . .	400
22.4	Flash EEPROM Control Block . . . . .	400
22.5	Flash EEPROM Arrays . . . . .	400
22.6	Flash EEPROM Registers . . . . .	401
22.7	Operation . . . . .	403
22.8	Programming the Flash EEPROM . . . . .	404
22.9	Erasing the Flash EEPROM . . . . .	405
22.10	Stop or Wait Mode . . . . .	405

### 22.2 Introduction

The two Flash EEPROM modules (32-Kbyte and 28-Kbyte) for the 68HC912D60A serve as electrically erasable and programmable, non-volatile ROM emulation memory. The modules can be used for program code that must either execute at high speed or is frequently executed, such as operating system kernels and standard subroutines, or they can be used for static data which is read frequently. The Flash EEPROM is ideal for program storage for single-chip applications allowing for field reprogramming.

### 22.3 Overview

The Flash EEPROM array is arranged in a 16-bit configuration and may be read as either bytes, aligned words or misaligned words. Access time is one bus cycle for byte and aligned word access and two bus cycles for misaligned word operations.

Programming is by aligned word. The Flash EEPROM module supports bulk erase only.

Each Flash EEPROM module has hardware interlocks which protect stored data from accidental corruption. An erase- and program-protected 8-Kbyte block for boot routines is located at \$6000–\$7FFF or \$E000–\$FFFF depending upon the mapped location of the Flash EEPROM arrays.

### 22.4 Flash EEPROM Control Block

A 4-byte register block for each module controls the Flash EEPROM operation. Configuration information is specified and programmed independently from the contents of the Flash EEPROM array. At reset, the 4-byte register section starts at address \$00F4/\$00F8.

### 22.5 Flash EEPROM Arrays

After reset, the 32K Flash EEPROM array is located from addresses \$8000 to \$FFFF and the 28K Flash EEPROM array is from \$1000 to \$7FFF. In expanded modes, the Flash EEPROM arrays are turned off. The Flash EEPROM can be mapped to an alternate address range. See [Operating Modes and Resource Mapping](#).



## 22.6 Flash EEPROM Registers

**FEE32LCK/FEE28LCK** — Flash EEPROM Lock Control Register

**\$00F4/\$00F8**

	Bit 7	6	5	4	3	2	1	Bit 0
	0	0	0	0	0	0	0	LOCK
RESET:	0	0	0	0	0	0	0	0

In normal modes the LOCK bit can only be written once after reset.

**LOCK** — Lock Register Bit

0 = Enable write to FEEMCR register

1 = Disable write to FEEMCR register

**FEE32MCR/FEE28MCR** — Flash EEPROM Module Configuration Register

**\$00F5/\$00F9**

	Bit 7	6	5	4	3	2	1	Bit 0
	0	0	0	0	0	0	0	BOOTP
RESET:	0	0	0	0	0	0	0	1

This register controls the operation of the Flash EEPROM array. BOOTP cannot be changed when the LOCK control bit in the FEELCK register is set or if ENPE in the FEECTL register is set.

**BOOTP** — Boot Protect

The boot blocks are located at \$6000–\$7FFF and \$E000–\$FFFF for each Flash EEPROM module.

0 = Enable erase and program of 8K byte boot block

1 = Disable erase and program of 8K byte boot block

**FEE32CTL/FEE28CTL** — Flash EEPROM Control Register

**\$00F7/\$00FB**

	Bit 7	6	5	4	3	2	1	Bit 0
	0	0	0	FEESWAI	HVEN	0	ERAS	PGM
RESET:	0	0	0	0	0	0	0	0

This register controls the programming and erasure of the Flash EEPROM.

### FEESWAI — Flash EEPROM Stop in Wait Control

- 0 = Do not halt Flash EEPROM clock when the part is in wait mode.
- 1 = Halt Flash EEPROM clock when the part is in wait mode.

### HVEN — High-Voltage Enable

This bit enables the charge pump to supply high voltages for program and erase operations in the array. HVEN can only be set if either PGM or ERAS are set and the proper sequence for program or erase is followed.

- 0 = Disables high voltage to array and charge pump off
- 1 = Enables high voltage to array and charge pump on

### ERAS — Erase Control

This bit configures the memory for erase operation. ERAS is interlocked with the PGM bit such that both bits cannot be equal to 1 or set to 1 at the same time.

- 0 = Erase operation is not selected.
- 1 = Erase operation selected.

### PGM — Program Control

This bit configures the memory for program operation. PGM is interlocked with the ERAS bit such that both bits cannot be equal to 1 or set to 1 at the same time.

- 0 = Program operation is not selected.
- 1 = Program operation selected.

## 22.7 Operation

The Flash EEPROM can contain program and data. On reset, it can operate as a bootstrap memory to provide the CPU with internal initialization information during the reset sequence.

### 22.7.1 Bootstrap Operation Single-Chip Mode

After reset, the CPU controlling the system will begin booting up by fetching the first program address from address \$FFFE.

### 22.7.2 Normal Operation

The Flash EEPROM allows a byte or aligned word read in one bus cycle. Misaligned word read require an additional bus cycle. The Flash EEPROM array responds to read operations only. Write operations are ignored.

### 22.7.3 Program/Erase Operation

An unprogrammed Flash EEPROM bit has a logic state of one. A bit must be programmed to change its state from one to zero. Erasing a bit returns it to a logic one. The Flash EEPROM has a minimum program/erase life of 100 cycles. Programming or erasing the Flash EEPROM is accomplished by a series of control register writes.

Programming is restricted to aligned word at a time as determined by internal signal SZ8 and ADDR[0]. The Flash EEPROM must first be completely erased prior to programming final data values.

Programming and erasing of Flash locations cannot be performed by code being executed from the FLASH memory. While these operations must be performed in the order shown, other unrelated operations may occur between the steps. Do not exceed  $t_{FPGM}$  maximum (40 $\mu$ s).

### 22.8 Programming the Flash EEPROM

Programming the Flash EEPROM is done on a row basis. A row consists of 64 consecutive bytes starting from addresses \$XX00, \$XX40, \$XX80 and \$XXC0. Use this step-by-step procedure to program a row of Flash memory.

1. Set the PGM bit. This configures the memory for program operation and enables the latching of address and data for programming.
2. Write to any Flash address with any data within the row address range desired.
3. Wait for a time,  $t_{NVS}$  (min. 10 $\mu$ s).
4. Set the HVEN bit.
5. Wait for a time,  $t_{PGS}$  (min. 5 $\mu$ s).
6. Write to the Flash address with data to the word desired to be programmed. If BOOTP is asserted, an attempt to program an address in the boot block will be ignored.
7. Wait for a time,  $t_{FPGM}$  (min. 30 $\mu$ s).
8. Repeat steps 6 and 7 until all the words within the row are programmed.
9. Clear the PGM bit.
10. Wait for a time,  $t_{NVH}$  (min. 5 $\mu$ s).
11. Clear the HVEN bit.
12. After time,  $t_{RCV}$  (min 1 $\mu$ s), the memory can be accessed in read mode again.

This program sequence is repeated throughout the memory until all data is programmed. For minimum overall programming time and least program disturb effect, the sequence should be part of an intelligent operation which iterates per row.

### 22.9 Erasing the Flash EEPROM

The following sequence demonstrates the recommended procedure for erasing any of the Flash EEPROM array.

1. Set the ERAS bit.
2. Write to any valid address in the Flash array. The data written and the address written are not important. The boot block will be erased only if the control bit BOOTP is negated.
3. Wait for a time,  $t_{NVS}$  (min. 10 $\mu$ s).
4. Set the HVEN bit.
5. Wait for a time,  $t_{ERAS}$  (min. 8ms).
6. Clear the ERAS bit.
7. Wait for a time,  $t_{NVHL}$  (min. 100 $\mu$ s).
8. Clear the HVEN bit.
9. After time,  $t_{RCV}$  (min 1 $\mu$ s), the memory can be accessed in read mode again.

### 22.10 Stop or Wait Mode

When stop or wait commands are executed, the MCU puts the Flash EEPROM in stop or wait mode. In these modes the Flash module will cease erasure or programming immediately.

**CAUTION:** *It is advised not to enter stop or wait modes when program or erase operation of the Flash array is in progress.*



## Section 23. Appendix: 68HC912D60A EEPROM

### 23.1 Contents

23.2	Introduction . . . . .	407
23.3	EEPROM Programmer's Model . . . . .	408
23.4	EEPROM Control Registers . . . . .	409
23.5	Program/Erase Operation. . . . .	415
23.6	Shadow Word Mapping . . . . .	415
23.7	Programming EEDIVH and EEDIVL Registers. . . . .	416

### 23.2 Introduction

The 68HC912D60A EEPROM nonvolatile memory is arranged in a 16-bit configuration. The EEPROM array may be read as either bytes, aligned words or misaligned words. Access times are one bus cycle for byte and aligned word access and two bus cycles for misaligned word operations.

Programming is by byte or aligned word. Attempts to program or erase misaligned words will fail. Only the lower byte will be latched and programmed or erased. Programming and erasing of the user EEPROM can be done in normal modes.

Each EEPROM byte or aligned word must be erased before programming. The EEPROM module supports byte, aligned word, row (32 bytes) or bulk erase, all using the internal charge pump. The erased state is \$FF. The EEPROM module has hardware interlocks which protect stored data from corruption by accidentally enabling the program/erase voltage. Programming voltage is derived from the internal  $V_{DD}$  supply with an internal charge pump.

### 23.3 EEPROM Programmer's Model

The EEPROM module consists of two separately addressable sections. The first is an eight-byte memory mapped control register block used for control, testing and configuration of the EEPROM array. The second section is the EEPROM array itself.

At reset, the eight-byte register section starts at address \$00EC and the EEPROM array is located from addresses \$0C00 to \$0FFF. Registers \$00EC-\$00ED are reserved.

Read/write access to the memory array section can be enabled or disabled by the EEON control bit in the INITEE register (\$0012). This feature allows the access of memory mapped resources that have lower priority than the EEPROM memory array. EEPROM control registers can be accessed regardless of the state of EEON. For information on re-mapping the register block and EEPROM address space, refer to [Operating Modes and Resource Mapping](#).

**CAUTION:** *It is strongly recommended to discontinue program/erase operations during WAIT (when EESWAI=1) or STOP modes since all program/erase activities will be terminated abruptly and considered unsuccessful.*

For lowest power consumption during WAIT mode, it is advised to turn off EEPGM.

The EEPROM module contains an extra word called SHADOW word which is loaded at reset into the EEMCR, EEDIVH and EEDIVL registers. To program the SHADOW word, when in special modes (SMODN=0), the NOSHW bit in EEMCR register must be cleared. Normal programming routines are used to program the SHADOW word which becomes accessible at address \$0FC0-\$0FC1 when NOSHW is cleared. At the next reset the SHADOW word data is loaded into the EEMCR, EEDIVH and EEDIVL registers. The SHADOW word can be protected from being programmed or erased by setting the SHPROT bit of EEPROT register.



A steady internal self-time clock is required to provide accurate counts to meet EEPROM program/erase requirements. This clock is generated via a programmable 10-bit prescaler register. Automatic program/erase termination is also provided.

In ordinary situations, with crystal operating properly, the steady internal self-time clock is derived from the input clock source (EXTALi). The divider value is as in EEDIVH:EEDIVL. In limp-home mode, where the oscillator clock has malfunctioned or is unavailable, the self-time clock is derived from the PLL with approximately 1 MHz frequency, with a predefined divider value of \$0023. Program/erase operation is not guaranteed in limp-home mode. The clock switching function is only applicable for permanent loss of crystal condition, so the program/erase will also not be guaranteed when the loss of crystal condition is intermittent.

It is strongly recommended that the clock monitor is enabled to ensure that the program/erase operation will be shutdown in the event of loss of crystal with a clock monitor reset, or switch to a limp-home mode clock. This will prevent unnecessary stress on the emulated EEPROM during oscillator failure.

## 23.4 EEPROM Control Registers

**EEDIVH** — EEPROM Modulus Divider

**\$00EE**

	Bit 7	6	5	4	3	2	1	Bit 0
	0	0	0	0	0	0	EEDIV9	EEDIV8
RESET:	0	0	0	0	0	0	— <sup>(1)</sup>	— <sup>(1)</sup>

1. Loaded from SHADOW word.

**EEDIVL** — EEPROM Modulus Divider

**\$00EF**

	Bit 7	6	5	4	3	2	1	Bit 0
	EEDIV7	EEDIV6	EEDIV5	EEDIV4	EEDIV3	EEDIV2	EEDIV1	EEDIV0
RESET:	— <sup>(1)</sup>	— <sup>(1)</sup>	— <sup>(1)</sup>	— <sup>(1)</sup>	— <sup>(1)</sup>	— <sup>(1)</sup>	— <sup>(1)</sup>	— <sup>(1)</sup>

1. Loaded from SHADOW word.

## EEDIV[9:0] — Prescaler divider

Loaded from SHADOW word at reset.

Read anytime. Write once in normal modes (SMODN =1) if EELAT = 0 and anytime in special modes (SMODN =0) if EELAT = 0.

The prescaler divider is required to produce a self-time clock with a fixed frequency around 28.6 KHz for the range of oscillator frequencies. The divider is set so that the oscillator frequency can be divided by a divide factor that can produce a 35  $\mu$ s +/- 2 $\mu$ s pulse.

**CAUTION:** *An incorrect or uninitialized value on EEDIV can result in overstress of EEPROM array during program/erase operation. It is also strongly recommend not to program EEPROM with oscillator frequencies less than 250 KHz.*

The EEDIV value is determined by the following formula:

$$EEDIV = INT[EXTALi \text{ (hz)} \times 35 \times 10^{-6} + 0.5]$$

**NOTE:** *INT[A] denotes the round down integer value of A. Program/erase cycles will not be activated when EEDIV = 0.*

**Table 23-1. EEDIV Selection**

Osc Freq.	Osc Period	Divide Factor	EEDIV
16 Mhz	62.5ns	560	\$0230
8 Mhz	125ns	280	\$0118
4 Mhz	250ns	140	\$008C
2 Mhz	500ns	70	\$0046
1 Mhz	1 $\mu$ s	35	\$0023
500 KHz	2 $\mu$ s	18	\$0012
250 KHz	4 $\mu$ s	9	\$0009

## EEMCR — EEPROM Module Configuration

**\$00F0**

	Bit 7	6	5	4	3	2	1	Bit 0
	NOBDML	NOSHW	RESERVED <sup>(1)</sup>	1	EESWAI	PROTLCK	DMY	
RESET:	— <sup>(2)</sup>	— <sup>(2)</sup>	— <sup>(2)</sup>	— <sup>(2)</sup>	1	1	0	0

- Bits 4 and 5 have test functions and should not be programmed.
- Loaded from SHADOW word.

Bits[7:4] are loaded at reset from the EEPROM SHADOW word.

**NOTE:** *The bits 5 and 4 are reserved for test purposes. These locations in SHADOW word should not be programmed otherwise some locations of regular EEPROM array will not be visible.*

NOBDML — Background Debug Mode Lockout Disable

0 = The BDM lockout is enabled.

1 = The BDM lockout is disabled.

Loaded from SHADOW word at reset.

Read anytime. Write anytime in special modes (SMODN=0).

NOSHW — SHADOW Word Disable

0 = The SHADOW word is enabled and accessible at address \$0FC0-\$0FC1.

1 = Regular EEPROM array at address \$0FC0-\$0FC1.

Loaded from SHADOW word at reset.

Read anytime. Write anytime in special modes (SMODN=0).

When NOSHW cleared, the regular EEPROM array bytes at address \$0FC0 and \$0FC1 are not visible. The SHADOW word is accessed instead for both read and program/erase operations. Bits[7:4] from the high byte of the SHADOW word, \$0FC0, are loaded to EEMCR[7:4]. Bits[1:0] from the high byte of the SHADOW word, \$0FC0, are loaded to EEDIVH[1:0]. Bits[7:0] from the low byte of the SHADOW word, \$0FC1, are loaded to EEDIVL[7:0]. BULK program/erase only applies if SHADOW word is enabled.

**NOTE:** *Bit 6 from high byte of SHADOW word should not be cleared (set to '0') in order to have the full EEPROM array visible. If Bit 6 from the high byte of the SHADOW word is cleared then the following thirty bytes \$0FC2-\$0FFF have no meaning and are reserved by Motorola.*

EESWAI — EEPROM Stops in Wait Mode

0 = The module is not affected during WAIT mode

1 = The module ceases to be clocked during WAIT mode

Read and write anytime.

**NOTE:** *The EESWAI bit should be cleared if the WAIT mode vectors are mapped in the EEPROM array.*

## Appendix: 68HC912D60A EEPROM

PROTLCK — Block Protect Write Lock

0 = Block protect bits and bulk erase protection bit can be written

1 = Block protect bits are locked

Read anytime. Write once in normal modes (SMODN = 1), set and clear any time in special modes (SMODN = 0).

DMY— Dummy bit

Read and write anytime.

EEPROT — EEPROM Block Protect

**\$00F1**

	Bit 7	6	5	4	3	2	1	Bit 0
	SHPROT	1	BPROT5	BPROT4	BPROT3	BPROT2	BPROT1	BPROT0
RESET:	1	1	1	1	1	1	1	1

Prevents accidental writes to EEPROM. Read anytime. Write anytime if EEPGM = 0 and PROTLCK = 0.

SHPROT — SHADOW Word Protection

0 = The SHADOW word can be programmed and erased.

1 = The SHADOW word is protected from being programmed and erased.

BPROT[5:0] — EEPROM Block Protection

0 = Associated EEPROM block can be programmed and erased.

1 = Associated EEPROM block is protected from being programmed and erased.

**Table 23-22. K byte EEPROM Block Protection**

Bit Name	Block Protected	Block Size
BPROT5	\$0800 to \$0BFF	1024 Bytes
BPROT4	\$0C00 to \$0DFF	512 Bytes
BPROT3	\$0E00 to \$0EFF	256 Bytes
BPROT2	\$0F00 to \$0F7F	128 Bytes
BPROT1	\$0F80 to \$0FBF	64 Bytes
BPROT0	\$0FC0 to \$0FFF	64 Bytes

**EEPROG** — EEPROM Control

**\$00F3**

	Bit 7	6	5	4	3	2	1	Bit 0
	BULKP	0	AUTO	BYTE	ROW	ERASE	EELAT	EEPGM
RESET:	1	0	0	0	0	0	0	0

**BULKP** — Bulk Erase Protection

0 = EEPROM can be bulk erased.

1 = EEPROM is protected from being bulk or row erased.

Read anytime. Write anytime if EEPGM = 0 and PROTLCK = 0.

**AUTO** — Automatic shutdown of program/erase operation.

EEPGM is cleared automatically after the program/erase cycles are finished when AUTO is set.

0 = Automatic clear of EEPGM is disabled.

1 = Automatic clear of EEPGM is enabled.

Read anytime. Write anytime if EEPGM = 0.

**BYTE** — Byte and Aligned Word Erase

0 = Bulk or row erase is enabled.

1 = One byte or one aligned word erase only.

Read anytime. Write anytime if EEPGM = 0.

**ROW** — Row or Bulk Erase (when BYTE = 0)

0 = Erase entire EEPROM array.

1 = Erase only one 32-byte row.

Read anytime. Write anytime if EEPGM = 0.

BYTE and ROW have no effect when ERASE = 0

**Table 23-3. Erase Selection**

BYTE	ROW	Block size
0	0	Bulk erase entire EEPROM array
0	1	Row erase 32 bytes
1	0	Byte or aligned word erase
1	1	Byte or aligned word erase

If BYTE = 1 only the location specified by the address written to the programming latches will be erased. The operation will be a byte or an aligned word erase depending on the size of written data.

### ERASE — Erase Control

0 = EEPROM configuration for programming.

1 = EEPROM configuration for erasure.

Read anytime. Write anytime if EEPGM = 0.

Configures the EEPROM for erasure or programming.

Unless BULKP is set, erasure is by byte, aligned word, row or bulk.

### EELAT — EEPROM Latch Control

0 = EEPROM set up for normal reads.

1 = EEPROM address and data bus latches set up for programming or erasing.

Read anytime.

Write anytime except when EEPGM = 1 or EEDIV = 0.

BYTE, ROW, ERASE and EELAT bits can be written simultaneously or in any sequence.

### EEPGM — Program and Erase Enable

0 = Disables program/erase voltage to EEPROM.

1 = Applies program/erase voltage to EEPROM.

The EEPGM bit can be set only after EELAT has been set. When EELAT and EEPGM are set simultaneously, EEPGM remains clear but EELAT is set.

The BULKP, AUTO, BYTE, ROW, ERASE and EELAT bits cannot be changed when EEPGM is set. To complete a program or erase cycle when AUTO bit is clear, two successive writes to clear EEPGM and EELAT bits are required before reading the programmed data. When AUTO bit is set, EEPGM is automatically cleared after the program or erase cycle is over. A write to an EEPROM location has no effect when EEPGM is set. Latched address and data cannot be modified during program or erase.

## 23.5 Program/Erase Operation

A program or erase operation should follow the sequence below if AUTO bit is clear:

1. Write BYTE, ROW and ERASE to desired value, write EELAT = 1
2. Write a byte or an aligned word to an EEPROM address
3. Write EEPGM = 1
4. Wait for programming,  $t_{\text{PROG}}$  or erase,  $t_{\text{ERASE}}$  delay time (10ms)
5. Write EEPGM = 0
6. Write EELAT = 0

If AUTO bit is set, steps 4 and 5 can be replaced by a step to poll the EEPGM bit until is cleared.

It is possible to program/erase more bytes or words without intermediate EEPROM reads, by jumping from step 5 to step 2.

## 23.6 Shadow Word Mapping

The shadow word is mapped to location  $\$_{\text{FC0}}$  and  $\$_{\text{FC1}}$  when the NOSHW bit in EEMCR register is zero. The value in the shadow word is loaded to the EEMCR, EEDIVH and EEDIVL after reset. [Table 23-4](#) shows the mapping of each bit from shadow word to the registers

**Table 23-4. Shadow word mapping**

Shadow word location	Register / Bit
$\$_{\text{FC0}}$ bit 7	EEMCR / NOBDML
$\$_{\text{FC0}}$ , bit 6	EEMCR / NOSHW
$\$_{\text{FC0}}$ , bit 5	EEMCR / bit 5 <sup>(1)</sup>
$\$_{\text{FC0}}$ , bit 4	EEMCR / bit 4 <sup>(1)</sup>
$\$_{\text{FC0}}$ , bit 3:2	not mapped <sup>(2)</sup>
$\$_{\text{FC0}}$ , bit 1:0	EEDIVH / bit 1:0
$\$_{\text{FC1}}$ , bit 7:0	EEMCR / bit 7:0

1. Reserved for testing. Must be set to one in user application.

2. Reserved. Must be set to one in user application for future compatibility.

### 23.7 Programming EEDIVH and EEDIVL Registers

The EEDIVH and EEDIVL registers must be correctly set according to the oscillator frequency before any EEPROM location can be programmed or erased.

#### 23.7.1 Normal mode

The EEDIVH and EEDIVL registers are write once in normal mode. Upon system reset, the application program is required to write correct divider value to EEDIVH and EEDIVL registers based on the oscillator frequency. After the first write, the value in the EEDIVH and EEDIVL registers is locked from being overwritten until the next reset. The EEPROM is then ready for standard program/erase routines.

**CAUTION:** *Runaway code can possibly corrupt the EEDIVH and EEDIVL registers if they are not initialized for the write once.*

#### 23.7.2 Special mode

If an existing application code with EEPROM program/erase routines is already fixed and the system is already operating at a known oscillator frequency, it is recommended to initialize the shadow word with the corresponding EEDIVH and EEDIVL values in special mode. The shadow word initializes EEDIVH and EEDIVL registers upon system reset to ensure software compatibility with existing code. Initializing the EEDIVH and EEDIVL registers in special modes (SMODN=0) is accomplished by the following steps.

1. Write correct divider value to EEDIVH and EEDIVL registers based on the oscillator frequency as per Table 17.
2. Remove the SHADOW word protection by clearing SHPROT bit in EEPROT register.
3. Clear NOSHW bit in EEMCR register to make the SHADOW word visible at \$0FC0-\$0FC1.
4. Write NOSHW bit in EEMCR register to make the SHADOW word visible at \$0FC0-\$0FC1.



5. Program bits 1 and 0 of the high byte of the SHADOW word and bits 7 to 0 of the low byte of the SHADOW word like a regular EEPROM location at address \$0FC0 and \$0FC1. Do not program other bits of the high byte of the SHADOW word (location \$0FC0); otherwise some regular EEPROM array locations will not be visible. At the next reset, the SHADOW values are loaded into the EEDIVH and EEDIVL registers. They do not require further initialization as long as the oscillator frequency of the target application is not changed.
6. Protect the SHADOW word by setting SHPROT bit in EEPROT register.



## Glossary

**A** — See “accumulators (A and B or D).”

**accumulators (A and B or D)** — Two 8-bit (A and B) or one 16-bit (D) general-purpose registers in the CPU. The CPU uses the accumulators to hold operands and results of arithmetic and logic operations.

**acquisition mode** — A mode of PLL operation with large loop bandwidth. Also see ‘tracking mode’.

**address bus** — The set of wires that the CPU or DMA uses to read and write memory locations.

**addressing mode** — The way that the CPU determines the operand address for an instruction. The M68HC12 CPU has 15 addressing modes.

**ALU** — See “arithmetic logic unit (ALU).”

**analogue-to-digital converter (ATD)** — The ATD module is an 8-channel, multiplexed-input successive-approximation analog-to-digital converter.

**arithmetic logic unit (ALU)** — The portion of the CPU that contains the logic circuitry to perform arithmetic, logic, and manipulation operations on operands.

**asynchronous** — Refers to logic circuits and operations that are not synchronized by a common reference signal.

**ATD** — See “analogue-to-digital converter”.

**B** — See “accumulators (A and B or D).”

**baud rate** — The total number of bits transmitted per unit of time.

**BCD** — See “binary-coded decimal (BCD).”

**binary** — Relating to the base 2 number system.

**binary number system** — The base 2 number system, having two digits, 0 and 1. Binary arithmetic is convenient in digital circuit design because digital circuits have two permissible voltage levels, low and high. The binary digits 0 and 1 can be interpreted to correspond to the two digital voltage levels.

**binary-coded decimal (BCD)** — A notation that uses 4-bit binary numbers to represent the 10 decimal digits and that retains the same positional structure of a decimal number. For example,

234 (decimal) = 0010 0011 0100 (BCD)

**bit** — A binary digit. A bit has a value of either logic 0 or logic 1.

**branch instruction** — An instruction that causes the CPU to continue processing at a memory location other than the next sequential address.

**break module** — The break module allows software to halt program execution at a programmable point in order to enter a background routine.

**breakpoint** — A number written into the break address registers of the break module. When a number appears on the internal address bus that is the same as the number in the break address registers, the CPU executes the software interrupt instruction (SWI).

**break interrupt** — A software interrupt caused by the appearance on the internal address bus of the same value that is written in the break address registers.

**bus** — A set of wires that transfers logic signals.

**bus clock** — See "CPU clock".

**byte** — A set of eight bits.

**CAN** — See "Motorola scalable CAN."

**CCR** — See "condition code register."

**central processor unit (CPU)** — The primary functioning unit of any computer system. The CPU controls the execution of instructions.

**CGM** — See "clock generator module (CGM)."

**clear** — To change a bit from logic 1 to logic 0; the opposite of set.

**clock** — A square wave signal used to synchronize events in a computer.

**clock generator module (CGM)** — The CGM module generates a base clock signal from which the system clocks are derived. The CGM may include a crystal oscillator circuit and/or phase-locked loop (PLL) circuit.

**comparator** — A device that compares the magnitude of two inputs. A digital comparator defines the equality or relative differences between two binary numbers.

**computer operating properly module (COP)** — A counter module that resets the MCU if allowed to overflow.

**condition code register (CCR)** — An 8-bit register in the CPU that contains the interrupt mask bit and five bits that indicate the results of the instruction just executed.

**control bit** — One bit of a register manipulated by software to control the operation of the module.

**control unit** — One of two major units of the CPU. The control unit contains logic functions that synchronize the machine and direct various operations. The control unit decodes instructions and generates the internal control signals that perform the requested operations. The outputs of the control unit drive the execution unit, which contains the arithmetic logic unit (ALU), CPU registers, and bus interface.

**COP** — See "computer operating properly module (COP)."

**CPU** — See "central processor unit (CPU)."

**CPU12** — The CPU of the MC68HC12 Family.

**CPU clock** — Bus clock select bits BCSP and BCSS in the clock select register (CLKSEL) determine which clock drives SYSCLK for the main system, including the CPU and buses. When EXTALi drives the SYSCLK, the CPU or bus clock frequency ( $f_o$ ) is equal to the EXTALi frequency divided by 2.

**CPU cycles** — A CPU cycle is one period of the internal bus clock, normally derived by dividing a crystal oscillator source by two or more so the high and low times will be equal. The length of time required to execute an instruction is measured in CPU clock cycles.

**CPU registers** — Memory locations that are wired directly into the CPU logic instead of being part of the addressable memory map. The CPU always has direct access to the information in these registers. The CPU registers in an M68HC12 are:

- A (8-bit accumulator)
- B (8-bit accumulator)
  - D (16-bit accumulator formed by concatenation of accumulators A and B)
- IX (16-bit index register)
- IY (16-bit index register)
- SP (16-bit stack pointer)
- PC (16-bit program counter)
- CCR (8-bit condition code register)

## Glossary

**cycle time** — The period of the operating frequency:  $t_{CYC} = 1/f_{OP}$ .

**D** — See “accumulators (A and B or D).”

**decimal number system** — Base 10 numbering system that uses the digits zero through nine.

**duty cycle** — A ratio of the amount of time the signal is on versus the time it is off. Duty cycle is usually represented by a percentage.

**ECT** — See “enhanced capture timer.”

**EEPROM** — Electrically erasable, programmable, read-only memory. A nonvolatile type of memory that can be electrically erased and reprogrammed.

**EPROM** — Erasable, programmable, read-only memory. A nonvolatile type of memory that can be erased by exposure to an ultraviolet light source and then reprogrammed.

**enhanced capture timer (ECT)** — The HC12 Enhanced Capture Timer module has the features of the HC12 Standard Timer module enhanced by additional features in order to enlarge the field of applications.

**exception** — An event such as an interrupt or a reset that stops the sequential execution of the instructions in the main program.

**fetch** — To copy data from a memory location into the accumulator.

**firmware** — Instructions and data programmed into nonvolatile memory.

**free-running counter** — A device that counts from zero to a predetermined number, then rolls over to zero and begins counting again.

**full-duplex transmission** — Communication on a channel in which data can be sent and received simultaneously.

**hexadecimal** — Base 16 numbering system that uses the digits 0 through 9 and the letters A through F.

**high byte** — The most significant eight bits of a word.

**illegal address** — An address not within the memory map

**illegal opcode** — A nonexistent opcode.

**index registers (IX and IY)** — Two 16-bit registers in the CPU. In the indexed addressing modes, the CPU uses the contents of IX or IY to determine the effective address of the operand. IX and IY can also serve as a temporary data storage locations.

**input/output (I/O)** — Input/output interfaces between a computer system and the external world. A CPU reads an input to sense the level of an external signal and writes to an output to change the level on an external signal.

**instructions** — Operations that a CPU can perform. Instructions are expressed by programmers as assembly language mnemonics. A CPU interprets an opcode and its associated operand(s) and instruction.

**inter-IC bus (I<sup>2</sup>C)** — A two-wire, bidirectional serial bus that provides a simple, efficient method of data exchange between devices.

**interrupt** — A temporary break in the sequential execution of a program to respond to signals from peripheral devices by executing a subroutine.

**interrupt request** — A signal from a peripheral to the CPU intended to cause the CPU to execute a subroutine.

**I/O** — See “input/output (I/O).”

**jitter** — Short-term signal instability.

**latch** — A circuit that retains the voltage level (logic 1 or logic 0) written to it for as long as power is applied to the circuit.

**latency** — The time lag between instruction completion and data movement.

**least significant bit (LSB)** — The rightmost digit of a binary number.

**logic 1** — A voltage level approximately equal to the input power voltage ( $V_{DD}$ ).

**logic 0** — A voltage level approximately equal to the ground voltage ( $V_{SS}$ ).

**low byte** — The least significant eight bits of a word.

**M68HC12** — A Motorola family of 16-bit MCUs.

**mark/space** — The logic 1/logic 0 convention used in formatting data in serial communication.

**mask** — 1. A logic circuit that forces a bit or group of bits to a desired state. 2. A photomask used in integrated circuit fabrication to transfer an image onto silicon.

**MCU** — Microcontroller unit. See “microcontroller.”

**memory location** — Each M68HC12 memory location holds one byte of data and has a unique address. To store information in a memory location, the CPU places the address of the location on the address bus, the data information on the data bus, and asserts the write signal. To read information from a memory location, the CPU places the address of the location on the address bus and asserts the read signal. In response to the read signal, the selected memory location places its data onto the data bus.

**memory map** — A pictorial representation of all memory locations in a computer system.

**MI-Bus** — See "Motorola interconnect bus".

**microcontroller** — Microcontroller unit (MCU). A complete computer system, including a CPU, memory, a clock oscillator, and input/output (I/O) on a single integrated circuit.

**modulo counter** — A counter that can be programmed to count to any number from zero to its maximum possible modulus.

**most significant bit (MSB)** — The leftmost digit of a binary number.

**Motorola interconnect bus (MI-Bus)** — The Motorola Interconnect Bus (MI Bus) is a serial communications protocol which supports distributed real-time control efficiently and with a high degree of noise immunity.

**Motorola scalable CAN (msCAN)** — The Motorola scalable controller area network is a serial communications protocol that efficiently supports distributed real-time control with a very high level of data integrity.

**msCAN** — See "Motorola scalable CAN".

**MSI** — See "multiple serial interface".

**multiple serial interface** — A module consisting of multiple independent serial I/O sub-systems, e.g. two SCI and one SPI.

**multiplexer** — A device that can select one of a number of inputs and pass the logic level of that input on to the output.

**nibble** — A set of four bits (half of a byte).

**object code** — The output from an assembler or compiler that is itself executable machine code, or is suitable for processing to produce executable machine code.

**opcode** — A binary code that instructs the CPU to perform an operation.

**open-drain** — An output that has no pullup transistor. An external pullup device can be connected to the power supply to provide the logic 1 output voltage.



**operand** — Data on which an operation is performed. Usually a statement consists of an operator and an operand. For example, the operator may be an add instruction, and the operand may be the quantity to be added.

**oscillator** — A circuit that produces a constant frequency square wave that is used by the computer as a timing and sequencing reference.

**OTPROM** — One-time programmable read-only memory. A nonvolatile type of memory that cannot be reprogrammed.

**overflow** — A quantity that is too large to be contained in one byte or one word.

**page zero** — The first 256 bytes of memory (addresses \$0000–\$00FF).

**parity** — An error-checking scheme that counts the number of logic 1s in each byte transmitted. In a system that uses odd parity, every byte is expected to have an odd number of logic 1s. In an even parity system, every byte should have an even number of logic 1s. In the transmitter, a parity generator appends an extra bit to each byte to make the number of logic 1s odd for odd parity or even for even parity. A parity checker in the receiver counts the number of logic 1s in each byte. The parity checker generates an error signal if it finds a byte with an incorrect number of logic 1s.

**PC** — See “program counter (PC).”

**peripheral** — A circuit not under direct CPU control.

**phase-locked loop (PLL)** — A clock generator circuit in which a voltage controlled oscillator produces an oscillation which is synchronized to a reference signal.

**PLL** — See “phase-locked loop (PLL).”

**pointer** — Pointer register. An index register is sometimes called a pointer register because its contents are used in the calculation of the address of an operand, and therefore points to the operand.

**polarity** — The two opposite logic levels, logic 1 and logic 0, which correspond to two different voltage levels,  $V_{DD}$  and  $V_{SS}$ .

**polling** — Periodically reading a status bit to monitor the condition of a peripheral device.

**port** — A set of wires for communicating with off-chip devices.

**prescaler** — A circuit that generates an output signal related to the input signal by a fractional scale factor such as 1/2, 1/8, 1/10 etc.

**program** — A set of computer instructions that cause a computer to perform a desired operation or operations.

## Glossary

**program counter (PC)** — A 16-bit register in the CPU. The PC register holds the address of the next instruction or operand that the CPU will use.

**pull** — An instruction that copies into the accumulator the contents of a stack RAM location. The stack RAM address is in the stack pointer.

**pullup** — A transistor in the output of a logic gate that connects the output to the logic 1 voltage of the power supply.

**pulse-width** — The amount of time a signal is on as opposed to being in its off state.

**pulse-width modulation (PWM)** — Controlled variation (modulation) of the pulse width of a signal with a constant frequency.

**push** — An instruction that copies the contents of the accumulator to the stack RAM. The stack RAM address is in the stack pointer.

**PWM period** — The time required for one complete cycle of a PWM waveform.

**RAM** — Random access memory. All RAM locations can be read or written by the CPU. The contents of a RAM memory location remain valid until the CPU writes a different value or until power is turned off.

**RC circuit** — A circuit consisting of capacitors and resistors having a defined time constant.

**read** — To copy the contents of a memory location to the accumulator.

**register** — A circuit that stores a group of bits.

**reserved memory location** — A memory location that is used only in special factory test modes. Writing to a reserved location has no effect. Reading a reserved location returns an unpredictable value.

**reset** — To force a device to a known condition.

**SCI** — See "serial communication interface module (SCI)."

**serial** — Pertaining to sequential transmission over a single line.

**serial communications interface module (SCI)** — A module that supports asynchronous communication.

**serial peripheral interface module (SPI)** — A module that supports synchronous communication.

**set** — To change a bit from logic 0 to logic 1; opposite of clear.

**shift register** — A chain of circuits that can retain the logic levels (logic 1 or logic 0) written to them and that can shift the logic levels to the right or left through adjacent circuits in the chain.

**signed** — A binary number notation that accommodates both positive and negative numbers. The most significant bit is used to indicate whether the number is positive or negative, normally logic 0 for positive and logic 1 for negative. The other seven bits indicate the magnitude of the number.

**software** — Instructions and data that control the operation of a microcontroller.

**software interrupt (SWI)** — An instruction that causes an interrupt and its associated vector fetch.

**SPI** — See "serial peripheral interface module (SPI)."

**stack** — A portion of RAM reserved for storage of CPU register contents and subroutine return addresses.

**stack pointer (SP)** — A 16-bit register in the CPU containing the address of the next available storage location on the stack.

**start bit** — A bit that signals the beginning of an asynchronous serial transmission.

**status bit** — A register bit that indicates the condition of a device.

**stop bit** — A bit that signals the end of an asynchronous serial transmission.

**subroutine** — A sequence of instructions to be used more than once in the course of a program. The last instruction in a subroutine is a return from subroutine (RTS) instruction. At each place in the main program where the subroutine instructions are needed, a jump or branch to subroutine (JSR or BSR) instruction is used to call the subroutine. The CPU leaves the flow of the main program to execute the instructions in the subroutine. When the RTS instruction is executed, the CPU returns to the main program where it left off.

**synchronous** — Refers to logic circuits and operations that are synchronized by a common reference signal.

**timer** — A module used to relate events in a system to a point in time.

**toggle** — To change the state of an output from a logic 0 to a logic 1 or from a logic 1 to a logic 0.

**tracking mode** — A mode of PLL operation with narrow loop bandwidth. Also see 'acquisition mode.'

**two's complement** — A means of performing binary subtraction using addition techniques. The most significant bit of a two's complement number indicates the sign of the number (1 indicates negative). The two's complement negative of a number is obtained by inverting each bit in the number and then adding 1 to the result.

**unbuffered** — Utilizes only one register for data; new data overwrites current data.

**unimplemented memory location** — A memory location that is not used. Writing to an unimplemented location has no effect. Reading an unimplemented location returns an unpredictable value.

**variable** — A value that changes during the course of program execution.

**VCO** — See "voltage-controlled oscillator."

**vector** — A memory location that contains the address of the beginning of a subroutine written to service an interrupt or reset.

**voltage-controlled oscillator (VCO)** — A circuit that produces an oscillating output signal of a frequency that is controlled by a dc voltage applied to a control input.

**waveform** — A graphical representation in which the amplitude of a wave is plotted against time.

**wired-OR** — Connection of circuit outputs so that if any output is high, the connection point is high.

**word** — A set of two bytes (16 bits).

**write** — The transfer of a byte of data from the CPU to a memory location.

# Revision History

This section lists the revision history of the document since the first release. Data for previous internal drafts is unavailable.

### 23.8 Changes from Rev 3.0 to Rev 4.0

Section	Page (in Rev 4.0)	Description of change
EEPROM	118, 411	Note referring to bit 6 of the SHADOW byte/word has been modified.

### 23.9 Changes from Rev 2.0 to Rev 3.0

Section	Page (in Rev 3.0)	Description of change
Pinout and Signal Descriptions	43	$C_a$ in <a href="#">Figure 3-5</a> changed to $C_p$
	45	Note added about consideration of crystal selection due to EMC emissions
Clock Functions	145	Note added about consideration of crystal selection due to EMC emissions
	149	Major rewrite of <a href="#">Limp-Home and Fast STOP Recovery modes</a> .
	167	<a href="#">System Clock Frequency Formulae</a> updated for clarification.
	169	<a href="#">Figure 12-6</a> modified for clarification.
	172	<a href="#">Figure 12-9</a> modified for clarification.
MSCAN Controller	291	First two bullets of sleep mode description updated
	304	SLPRQ = 1 description updated

## Revision History

Section	Page (in Rev 3.0)	Description of change
Electrical Specifications	365	Sentence about preliminary status removed
	369	Added note about typical values for 2 and 4Hz columns of <a href="#">Table 20-4</a> . Added note for analog supply current in <a href="#">Table 20-5</a> .
	370	Expanded table note 3 to define conditions for accuracy testing.
	372	Changes to maximum EEPROM erase and data retention times
	374	$f_{XTAL}$ removed
	374	Footnote added restricting external oscillator operating frequency to 8MHz when using a quartz crystal
	386	Table footnote removed from <a href="#">Table 20-16</a> regarding $V_{DDPLL}$
Appendix: CGM Practical Aspects	388	Added section on DC bias.
	389	Point 3 removed regarding high frequency resonators
	392	In paragraph 2, C changed to $C_0$ , R changed to $R_0$
	393	In <a href="#">Table 21-1</a> In header, C changed to $C_0$ , R changed to $R_0$ Extra column added for $C_p$
	394	In <a href="#">Table 21-2</a> In header, C changed to $C_0$ , R changed to $R_0$ Extra column added for $C_p$
	397	New bullets added

### 23.10 Changes from Rev 1.0 to Rev 2.0

Section	Page (in Rev 2.0)	Description of change
MSI	230	Clarification of SP0DR register state on reset.
Electrical Specifications	354	Change to operating conditions of Key Wake-up table.



**HOW TO REACH US:**

**USA/EUROPE/LOCATIONS NOT LISTED:**

Motorola Literature Distribution;  
P.O. Box 5405, Denver, Colorado 80217  
1-303-675-2140 or 1-800-441-2447

**JAPAN:**

Motorola Japan Ltd.; SPS, Technical Information Center,  
3-20-1, Minami-Azabu Minato-ku, Tokyo 106-8573 Japan  
81-3-3440-3569

**ASIA/PACIFIC:**

Motorola Semiconductors H.K. Ltd.;  
Silicon Harbour Centre, 2 Dai King Street,  
Tai Po Industrial Estate, Tai Po, N.T., Hong Kong  
852-26668334

**TECHNICAL INFORMATION CENTER:**

1-800-521-6274

**HOME PAGE:**

<http://www.motorola.com/semiconductors>

Information in this document is provided solely to enable system and software implementers to use Motorola products. There are no express or implied copyright licenses granted hereunder to design or fabricate any integrated circuits or integrated circuits based on the information in this document.

Motorola reserves the right to make changes without further notice to any products herein. Motorola makes no warranty, representation or guarantee regarding the suitability of its products for any particular purpose, nor does Motorola assume any liability arising out of the application or use of any product or circuit, and specifically disclaims any and all liability, including without limitation consequential or incidental damages. "Typical" parameters which may be provided in Motorola data sheets and/or specifications can and do vary in different applications and actual performance may vary over time. All operating parameters, including "Typicals" must be validated for each customer application by customer's technical experts. Motorola does not convey any license under its patent rights nor the rights of others. Motorola products are not designed, intended, or authorized for use as components in systems intended for surgical implant into the body, or other applications intended to support or sustain life, or for any other application in which the failure of the Motorola product could create a situation where personal injury or death may occur. Should Buyer purchase or use Motorola products for any such unintended or unauthorized application, Buyer shall indemnify and hold Motorola and its officers, employees, subsidiaries, affiliates, and distributors harmless against all claims, costs, damages, and expenses, and reasonable attorney fees arising out of, directly or indirectly, any claim of personal injury or death associated with such unintended or unauthorized use, even if such claim alleges that Motorola was negligent regarding the design or manufacture of the part.



Motorola and the Stylized M Logo are registered in the U.S. Patent and Trademark Office. digital dna is a trademark of Motorola, Inc. All other product or service names are the property of their respective owners. Motorola, Inc. is an Equal Opportunity/Affirmative Action Employer.

© Motorola, Inc. 2003

MC68HC912D60/D



## 68HC912D60 : Microcontroller

[SUBSCRIBE FOR UPDATES](#)

The MC68HC912D60 microcontroller unit (MCU) is a 16-bit device composed of standard on-chip peripherals including a 16-bit central processing unit (CPU12), 60-Kbyte flash EEPROM, 2-Kbyte RAM, 1-Kbyte EEPROM, a dual asynchronous serial communications interface (SCI), a serial peripheral interface (SPI), an 8-channel enhanced capture timer and 16-bit pulse accumulator, a 10-bit analog-to-digital converter (ADC) with up to 16 channels, a four-channel pulse-width modulator (PWM), and a CAN 2.0B compatible controller (MSCAN12). System resource mapping, clock generation, interrupt control and bus interfacing are managed by the Lite integration module (LIM). The MC68HC912D60 has full 16-bit data paths throughout, however, the multiplexed external bus can operate in an 8-bit narrow mode so single 8-bit wide memory can be interfaced for lower cost systems.


[Block Diagram](#)

### 68HC912D60 Features

- 16-Bit CPU12
  - Upward Compatible with M68HC11 Instruction Set
  - Interrupt Stacking and Programmer's Model Identical to M68HC11
  - 20-Bit ALU
  - Instruction Queue
  - Enhanced Indexed Addressing
  - Fuzzy Logic Instructions
- Multiplexed Bus
  - Single Chip or Expanded
  - 16/16 Wide or 16/8 Narrow Modes
- Memory
  - 60-Kbyte Flash EEPROM with 2-Kbyte Erase-Protected Boot Block
  - 1-KByte EEPROM
  - 2-Kbyte RAM with Single-Cycle Access for Aligned or Misaligned Read/Write
- Up to 16 Channel, 10-Bit Analog-to-Digital Converter

[Return to Top](#)

### Page Contents:

- [Features](#)
- [Documentation](#)
- [Tools](#)
- [Applications](#)
- [Rich Media](#)
- [Orderable Parts](#) 
- [Related Links](#)

### Other Info:
















- [FAQs](#)
- [3rd Party Design Help](#)
- [Training](#)
- [3rd Party Tool](#)
- [Vendors](#)
- [3rd Party Trainers](#)

### Rate this Page



Care to Comment?

**Documentation**  
**Application Note**

ID	Name	Vendor ID	Format	Size K	Rev #	Date Last Modified	Order Availability
<a href="#">AN1050_D</a>	Designing for Electromagnetic Compatibility (EMC) with HCMOS Microcontrollers	MOTOROLA	pdf	82	0	1/01/2000	-
<a href="#">AN1259/D</a>	System Design and Layout Techniques for Noise Reduction in MCU-Based Systems	MOTOROLA	pdf	78	0	1/01/1995	<a href="#">ORDER</a> 
<a href="#">AN1263/D</a>	Designing for Electromagnetic Compatibility with Single-Chip Microcontrollers	MOTOROLA	pdf	104	0	1/01/1995	<a href="#">ORDER</a> 
<a href="#">AN1280/D</a>	Using and Extending D-Bug12 Routines	MOTOROLA	pdf	70	0	1/01/1996	<a href="#">ORDER</a> 
<a href="#">AN1280A/D</a>	Using the Callable Routines in D-Bug12	MOTOROLA	pdf	63	0	1/01/1997	<a href="#">ORDER</a> 
<a href="#">AN1282/D</a>	Board Strategies for Ensuring Optimum Frequency Synthesizer Performance	MOTOROLA	pdf	65	0	1/01/1999	<a href="#">ORDER</a> 
<a href="#">AN1284/D</a>	Transporting M68HC11 Code to M68HC12 Devices	MOTOROLA	pdf	175	0	1/01/1996	<a href="#">ORDER</a> 
<a href="#">AN1516/D</a>	Liquid Level Control Using a Motorola Pressure Sensor	MOTOROLA	pdf	77	2	1/24/2003	<a href="#">ORDER</a> 
<a href="#">AN1705/D</a>	Noise Reduction Techniques for Microcontroller-Based Systems	MOTOROLA	pdf	67	0	1/01/1999	<a href="#">ORDER</a> 
<a href="#">AN1716/D</a>	Using M68HC12 Indexed Indirect Addressing	MOTOROLA	pdf	77	1	1/01/1997	<a href="#">ORDER</a> 
<a href="#">AN1771/D</a>	Precision Sine-Wave Tone Synthesis Using 8-Bit MCUs	MOTOROLA	pdf	250	0	1/01/1998	<a href="#">ORDER</a> 
<a href="#">AN1775/D</a>	Expanding Digital Input with an A/D Converter	MOTOROLA	pdf	86	1	1/01/1998	<a href="#">ORDER</a> 
<a href="#">AN1783/D</a>	Determining MCU Oscillator Start-Up Parameters	MOTOROLA	pdf	48	1	1/01/1999	<a href="#">ORDER</a> 
<a href="#">AN1828/D</a>	FLASH Programming Via CAN	MOTOROLA	pdf	160	1	2/13/2002	<a href="#">ORDER</a> 
<a href="#">AN1837/D</a>	Non-Volatile Memory Technology Overview	MOTOROLA	pdf	116	0	3/27/2000	<a href="#">ORDER</a> 
<a href="#">AN2010/D</a>	Using the Motorola msCAN Filter Configuration Tool	MOTOROLA	pdf	97	1	10/11/2001	<a href="#">ORDER</a> 
<a href="#">AN2103/D</a>	Local Interconnect Network (LIN) Demonstration	MOTOROLA	pdf	953	0	12/01/2000	<a href="#">ORDER</a> 
<a href="#">AN2104/D</a>	Using Background Debug Mode for the M68HC12 Family	MOTOROLA	pdf	353	0	2/02/2001	<a href="#">ORDER</a> 
<a href="#">AN2166SW</a>	Software for AN2166 zipped	MOTOROLA	zip	202	0	9/05/2001	-
<a href="#">AN2189/D</a>	Using the Clock Generation Module on the HC12 D Family	MOTOROLA	pdf	90	0	9/27/2001	<a href="#">ORDER</a> 
<a href="#">AN2219/D</a>	Using PLL to indicate Oscillator Start-Up Performance during Power On Reset	MOTOROLA	pdf	92	0	12/21/2001	<a href="#">ORDER</a> 
<a href="#">AN2255/D</a>	MSCAN Low-Power Applications	MOTOROLA	pdf	81	0	2/11/2002	<a href="#">ORDER</a> 
<a href="#">AN2283/D</a>	Motorola Scalable Controller Area Network (MSCAN) Interrupts	MOTOROLA	pdf	393	0	8/21/2002	<a href="#">ORDER</a> 
<a href="#">AN2321/D</a>	Designing for Board Level Electromagnetic Compatibility	MOTOROLA	pdf	1628	0	8/15/2002	<a href="#">ORDER</a> 
<a href="#">AN2342</a>	Opto Isolation Circuits For In Circuit Debugging of 68HC9(S)12 and 68HC908 Microcontrollers	MOTOROLA	pdf	155	0	9/25/2002	<a href="#">ORDER</a> 
<a href="#">AN2438/D</a>	ADC Definitions and Specifications	MOTOROLA	pdf	297	0	2/21/2003	<a href="#">ORDER</a> 

## Brochure

ID	Name	Vendor ID	Format	Size K	Rev #	Date Last Modified	Order Availability
<a href="#">FLYREMBEDFLASH/D</a>	Embedded Flash: Changing the Technology World for the Better	MOTOROLA	pdf	68	2	5/21/2003	<a href="#">ORDER</a>

## Data Sheets

ID	Name	Vendor ID	Format	Size K	Rev #	Date Last Modified	Order Availability
<a href="#">MC68HC912D60</a>	MC68HC12D60, MC68HC912D60 Advance Information	MOTOROLA	pdf	2135	4.0	11/12/2003	<a href="#">ORDER</a>

## Engineering Bulletin

ID	Name	Vendor ID	Format	Size K	Rev #	Date Last Modified	Order Availability
<a href="#">EB376/D</a>	A comparison of the MC9S12DP256 (mask set 0K36N) versus the HC12	MOTOROLA	pdf	250	2	10/31/2001	<a href="#">ORDER</a>
<a href="#">EB396/D</a>	Use of OSC2/XTAL as a Clock Output on Motorola Microcontrollers	MOTOROLA	pdf	49	0	6/19/2002	<a href="#">ORDER</a>
<a href="#">EB611</a>	EB611/D: HC11 and HC12 Families' Pulse Accumulator	MOTOROLA	pdf	0	0	7/10/2003	<a href="#">ORDER</a>

## Errata - [Click here for important errata information](#)

ID	Name	Vendor ID	Format	Size K	Rev #	Date Last Modified	Order Availability
<a href="#">68HC912D60MSE1/D</a>	M68HC912D60 Device Information Sheet: 1F68K Mask Sets	MOTOROLA	pdf	187	1	3/01/2001	-
<a href="#">68HC912D60MSE4/D</a>	M68HC912D60 Device Information Sheet: 4F73K Mask Sets	MOTOROLA	pdf	138	2	3/14/2001	-
<a href="#">68HC912D60MSE5/D</a>	M68HC912D60 Device Information Sheet: 0K75F Mask Sets	MOTOROLA	pdf	116	2	3/01/2001	-

## Fact Sheets

ID	Name	Vendor ID	Format	Size K	Rev #	Date Last Modified	Order Availability
<a href="#">CWDEVSTUDFACTHC08</a>	Development Studio	MOTOROLA	pdf	48	2	5/13/2002	-

## Product Change Notices

ID	Name	Vendor ID	Format	Size K	Rev #	Date Last Modified	Order Availability
<a href="#">PCN7917</a>	20X20 LQFP ASSY MOVE FROM SHC TO KLM	MOTOROLA	htm	24	0	8/19/2002	-
<a href="#">PCN8143</a>	TSC8/MOS 12 TRANSFER-HC12 FLASH DEVICES	MOTOROLA	htm	14	0	10/22/2002	-
<a href="#">PCN8658</a>	HC(9)12D60 AMBIENT TEST ELIMINATION(ATE)	MOTOROLA	htm	5	0	3/19/2003	-

## Reference Manual

ID	Name	Vendor ID	Format	Size K	Rev #	Date Last Modified	Order Availability
<a href="#">CPU12RG/D</a>	CPU12 Reference Guide	MOTOROLA	pdf	996	2	11/26/2001	<a href="#">ORDER</a>
<a href="#">CPU12RM</a>	HCS12 and M68HC12 CPU12 Reference Manual	MOTOROLA	pdf	0	3	4/17/2003	<a href="#">ORDER</a>

## Selector Guide

ID	Name	Vendor ID	Format	Size K	Rev #	Date Last Modified	Order Availability
<a href="#">SG1002</a>	Analog Selector Guide - Quarter 4, 2003	MOTOROLA	pdf	579	0	10/24/2003	<a href="#">ORDER</a>
<a href="#">SG1006</a>	Microcontrollers Selector Guide - Quarter 4, 2003	MOTOROLA	pdf	826	0	10/24/2003	<a href="#">ORDER</a>
<a href="#">SG1010</a>	Sensors Selector Guide - Quarter 4, 2003	MOTOROLA	pdf	219	0	10/24/2003	<a href="#">ORDER</a>
<a href="#">SG1011</a>	Software and Development Tools Selector Guide - Quarter 4, 2003	MOTOROLA	pdf	287	0	10/24/2003	<a href="#">ORDER</a>
<a href="#">SG2000CR</a>	Application Selector Guide Index and Cross-Reference.	MOTOROLA	pdf	95	3	11/11/2003	<a href="#">ORDER</a>

## Users Guide

ID	Name	Vendor ID	Format	Size K	Rev #	Date Last Modified	Order Availability
<a href="#">M68EVB912D60/D</a>	M68EVB912D60 Evaluation Board User's Manual	MOTOROLA	pdf	33	1	3/01/1999	-

[Return to Top](#)

## 68HC912D60 Tools

### Hardware Tools

#### Emulators/Probes/Wigglers

ID	Name	Vendor ID	Format	Size K	Rev #	Order Availability
<a href="#">BDI1000/BDI2000</a>	BDI1000/BDI2000	<a href="#">ABATRON</a>	-	-	-	-
<a href="#">IC20000</a>	iC2000 PowerEmulator	<a href="#">ISYS</a>	-	-	-	-
<a href="#">IC30001</a>	iC3000 ActiveEmulator	<a href="#">ISYS</a>	-	-	-	-
<a href="#">IC40000</a>	iC4000 ActiveEmulator	<a href="#">ISYS</a>	-	-	-	-
<a href="#">EMUL12-PC</a>	HC12 & HCS12 Emulator BDM and Full-Featured Emulators for all HCS12 and HC12 derivatives. 5V and 3.3V operation to above 25MHz bus speed. Extensive support for debug through Resets, Power-Downs, Limp-Home and full PLL use. Unlimited number of breakpoints.	<a href="#">NOHAU</a>	-	-	-	-

#### Evaluation/Development Boards and Systems

ID	Name	Vendor ID	Format	Size K	Rev #	Order Availability
<a href="#">M68KIT912D60A</a>	Development Tools	MOTOROLA	-	-	-	<a href="#">BUY</a>

## Software

### Application Software

#### Code Examples

ID	Name	Vendor ID	Format	Size K	Rev #	Order Availability
<a href="#">HC12_LABCOD</a>	Assembly examples from training course	MOTOROLA	zip	26	-	-

## DBug ROM Monitors

ID	Name	Vendor ID	Format	Size K	Rev #	Order Availability
<a href="#">DB12S12FW</a>	DB12S12FW The zip file contains S-Records and documentation for D-Bug12. This version runs on all MC9S12Dx256, MC9S12Dx128, MC9S12A256, MC9S12A128, MC9S12H256 and the BDM Programmer. This firmware supports programming all Flash HC12 and HCS12 devices.	MOTOROLA	zip	1178	4.0.0b24	-
<a href="#">MC68HC912D60EVBFW22</a>	D-Bug12 for MC68HC912D60EVB The zip file contains S-Records and documentation for D-Bug12 v3.0.0b22 for the MC68HC912D60 EVB. This distribution contains a bootloader that runs on the 912D60 & the 912D60A	MOTOROLA	zip	409	3.0.0b22	-

## Operating Systems

ID	Name	Vendor ID	Format	Size K	Rev #	Order Availability
<a href="#">CMX-RTX</a>	CMX-RTX	<a href="#">CMX</a>	-	-	-	-

## Protocol Stacks


ID	Name	Vendor ID	Format	Size K	Rev #	Order Availability
<a href="#">CMX-MICRONET</a>	CMX-MicroNet	<a href="#">CMX</a>	-	-	-	-

## Software Tools


### Assemblers

ID	Name	Vendor ID	Format	Size K	Rev #	Order Availability
<a href="#">AS12SRCASM</a>	C source code for freeware assembler	MOTOROLA	zip	67	-	-
<a href="#">SRECCVTSW</a>	SRecCvtSW The zip file contains the .exe file and documentation for SRecCvt; a command line tool for the conversion and reformatting of Motorola S-Record object files. Also included is a GUI interface to the command line tool for Windows and Mac OSX.	MOTOROLA	zip	1603	1.0.17	-
<a href="#">ADX-12</a>	ADX-12 Macro Assembler-Linker and IDE	<a href="#">AVOCET</a>	-	-	-	-
<a href="#">AX6812</a>	AX6812 relocatable and absolute macro assembler for HC12/HCS12	<a href="#">COSMIC</a>	-	-	-	-

### Compilers

ID	Name	Vendor ID	Format	Size K	Rev #	Order Availability
<a href="#">CWHC12</a>	CodeWarrior Development Tools for HC12	<a href="#">METROWERKS</a>	-	-	-	<a href="#">BUY</a> 
<a href="#">CX6812</a>	CX6812 C Cross Compiler for HC12/HCS12	<a href="#">COSMIC</a>	-	-	-	-
<a href="#">ICC12 PRO</a>	ICC12 V6 PRO	<a href="#">IMAGE</a>	-	-	-	-
<a href="#">ICC12 STD</a>	ICC12 V6 STD	<a href="#">IMAGE</a>	-	-	-	-

### Debuggers

ID	Name	Vendor ID	Format	Size K	Rev #	Order Availability
<a href="#">CWHC12</a>	CodeWarrior Development Tools for HC12	<a href="#">METROWERKS</a>	-	-	-	<a href="#">BUY</a> 
<a href="#">ZAP 6812 ICD</a>	ZAP 6812 BDM Debugger and Flash Programmer	<a href="#">COSMIC</a>	-	-	-	-
<a href="#">ZAP 6812 SIM</a>	ZAP HC12/HCS12 Simulator Debugger	<a href="#">COSMIC</a>	-	-	-	-
<a href="#">NOICE12</a>	NoICE12	<a href="#">IMAGE</a>	-	-	-	-

## IDE (Integrated Development Environment)

ID	Name	Vendor ID	Format	Size K	Rev #	Order Availability
<a href="#">CWHC12</a>	CodeWarrior Development Tools for HC12	<a href="#">METROWERKS</a>	-	-	-	<a href="#">BUY</a>
<a href="#">IDEA12</a>	IDEA12 - Integrated Development Environment for HC12/HCS12	<a href="#">COSMIC</a>	-	-	-	-
<a href="#">IC-SW-OPR</a>	winIDEA	<a href="#">ISYS</a>	-	-	-	-

[Return to Top](#)

## Applications

### Automotive

#### Chassis/Safety

[Anti-Lock Braking Systems](#)

[Return to Top](#)

## Rich Media

### Rich Media

#### Webcast

ID	Name	Vendor ID	Format	Size K	Rev #	Order Availability
<a href="#">RMWCHCS12</a>	HCS12 16-bit Microcontroller Overview Tune in to our webcast, to learn about Motorola's next generation of the 68HC12 architecture.	MOTOROLA	htm	3	1.0	-

[Return to Top](#)

## Orderable Parts Information

PartNumber	Package Info	Tape and Reel	Life Cycle Description (code)	Budgetary Price QTY 1000+ (\$US)	Additional Info	Order Availability
MC912D60CCFU	<a href="#">QFP 80</a> <a href="#">14*14*2.2P0.65</a>	No	PRODUCT RAPID GROWTH(2)	-	<a href="#">more</a>	-
MC912D60CCPV	<a href="#">LQFP 112</a> <a href="#">20*20*1.4P0.65</a>	No	PRODUCT NEWLY INTRO'D/RAMP-UP(1)	-	<a href="#">more</a>	<a href="#">BUY</a>
MC912D60CMFU	<a href="#">QFP 80</a> <a href="#">14*14*2.2P0.65</a>	No	PRODUCT RAPID GROWTH(2)	-	<a href="#">more</a>	-
MC912D60CMPV	<a href="#">LQFP 112</a> <a href="#">20*20*1.4P0.65</a>	No	PRODUCT NEWLY INTRO'D/RAMP-UP(1)	-	<a href="#">more</a>	-
MC912D60CVFU	<a href="#">QFP 80</a> <a href="#">14*14*2.2P0.65</a>	No	PRODUCT RAPID GROWTH(2)	-	<a href="#">more</a>	-
MC912D60CVPV	<a href="#">LQFP 112</a> <a href="#">20*20*1.4P0.65</a>	No	PRODUCT NEWLY INTRO'D/RAMP-UP(1)	-	<a href="#">more</a>	<a href="#">BUY</a>

MC912D60PCFU	<a href="#">QFP 80</a> <a href="#">14*14*2.2P0.65</a>	No	PRODUCT RAPID GROWTH(2)	-	<a href="#">more</a>	-
MC912D60PCPV	<a href="#">LQFP 112</a> <a href="#">20*20*1.4P0.65</a>	No	PRODUCT NEWLY INTRO'D/RAMP-UP(1)	-	<a href="#">more</a>	-
MC912D60PMFU	<a href="#">QFP 80</a> <a href="#">14*14*2.2P0.65</a>	No	PRODUCT RAPID GROWTH(2)	-	<a href="#">more</a>	-
MC912D60PMPV	<a href="#">LQFP 112</a> <a href="#">20*20*1.4P0.65</a>	No	PRODUCT NEWLY INTRO'D/RAMP-UP(1)	-	<a href="#">more</a>	-
MC912D60PVFU	<a href="#">QFP 80</a> <a href="#">14*14*2.2P0.65</a>	No	PRODUCT RAPID GROWTH(2)	-	<a href="#">more</a>	-
MC912D60PVPV	<a href="#">LQFP 112</a> <a href="#">20*20*1.4P0.65</a>	No	PRODUCT NEWLY INTRO'D/RAMP-UP(1)	-	<a href="#">more</a>	-
XC68HC912D60MFU8	<a href="#">QFP 80</a> <a href="#">14*14*2.2P0.65</a>	No	NOT RECOMMENDED(DECLINING)(5)	\$13.01	<a href="#">more</a>	<a href="#">BUY</a> 
XC68HC912D60MPV8	<a href="#">LQFP 112</a> <a href="#">20*20*1.4P0.65</a>	No	NOT RECOMMENDED(DECLINING)(5)	\$13.01	<a href="#">more</a>	<a href="#">BUY</a> 
XGHC912D60MFU8R2		Yes	PRODUCT DECLINE(5)	-	<a href="#">more</a>	-

**NOTE:** Are you looking for an obsolete orderable part? Click [HERE](#) to check our distributors' inventory.

[Return to Top](#)

#### Related Links

- [▶ Analog](#)
- [▶ Automotive](#)
- [▶ Microcontrollers](#)
- [▶ Motor Control](#)
- [▶ Programming the Motorola M68HC12 Family](#)
- [▶ Software and Hardware Engineering - Motorola M68HC12](#)
- [▶ Embedded Microcontrollers](#)
- [▶ Single- and Multi-Chip Microcontroller Interfacing](#)
- [▶ Embedded Microcomputer Systems - Real Time Interfacing](#)

[Return to Top](#)