

LEAD-FREE P/N
85995-X03LF

PLATING CODE X	PLATING CONTACT AREA
1	1.3 μm Au MIN

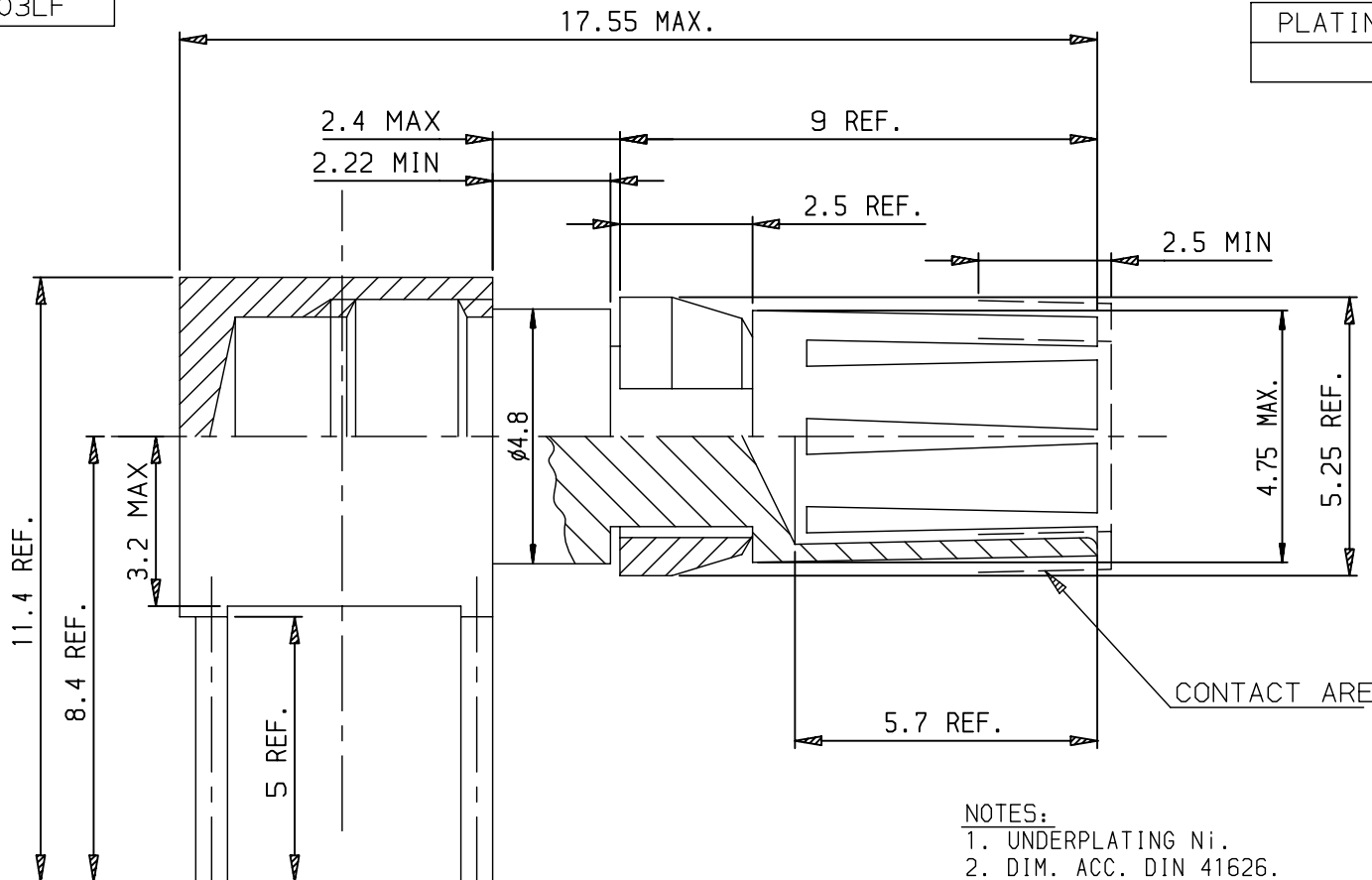

- NOTES:
1. UNDERPLATING Ni.
 2. DIM. ACC. DIN 41626.
 3. THIS PRODUCT WITH "LF" SUFFIX MEETS EUROPEAN UNION DIRECTIVES AND OTHER COUNTRY REGULATIONS AS DESCRIBED IN GS -22-008.
 4. THE PRODUCT WILL WITHSTAND EXPOSURE TO 260 DEGREE PEAK TEMPERATURE TO 30 SECONDS IN A WAVE SOLDER APPLICATION WITH A 1.6 mm MINIMUM THICK PCB
 5. PACKAGING SPEC: SEE GS-14-920

European Views

www.fciconnect.com		surface ISO 1302 ✓	tolerance std ISO 406 ISO 1101	projection mm
TOLERANCES UNLESS OTHERWISE SPECIFIED				
Dr	GOISNARD	2006/03/06	0.X ±0.1	size A3
Eng	GOISNARD	2006/03/06	0.XX ±0.1	Scale 10
Chr	LEGARE	2006/03/06	0.XX ±2*	ECN LS08-0057
Appr	LEGARE	2006/03/06	0.XXX ±0.1	Spec ref -
Product family			METRAL	
FCI title POWER INSERT RECEPTACLE RA STB		dwg no 85995		Rev. G
catalog no		CUSTOMER sheet 1 of 2		

rev	ecn no	dr	date
E	LS06-0022	LGO	2006/03/06
F	LS07-0214	LGO	2007/08/21
G	LS08-0057	LGO	2008/02/18
-	-	-	-
-	-	-	-
-	-	-	-



Copyright FCI.

LEAD-FREE P/N	
85995-X14LF	OBSOLETE

PLATING CODE X	CONTACT AREA
1	1.3 μm Au MIN

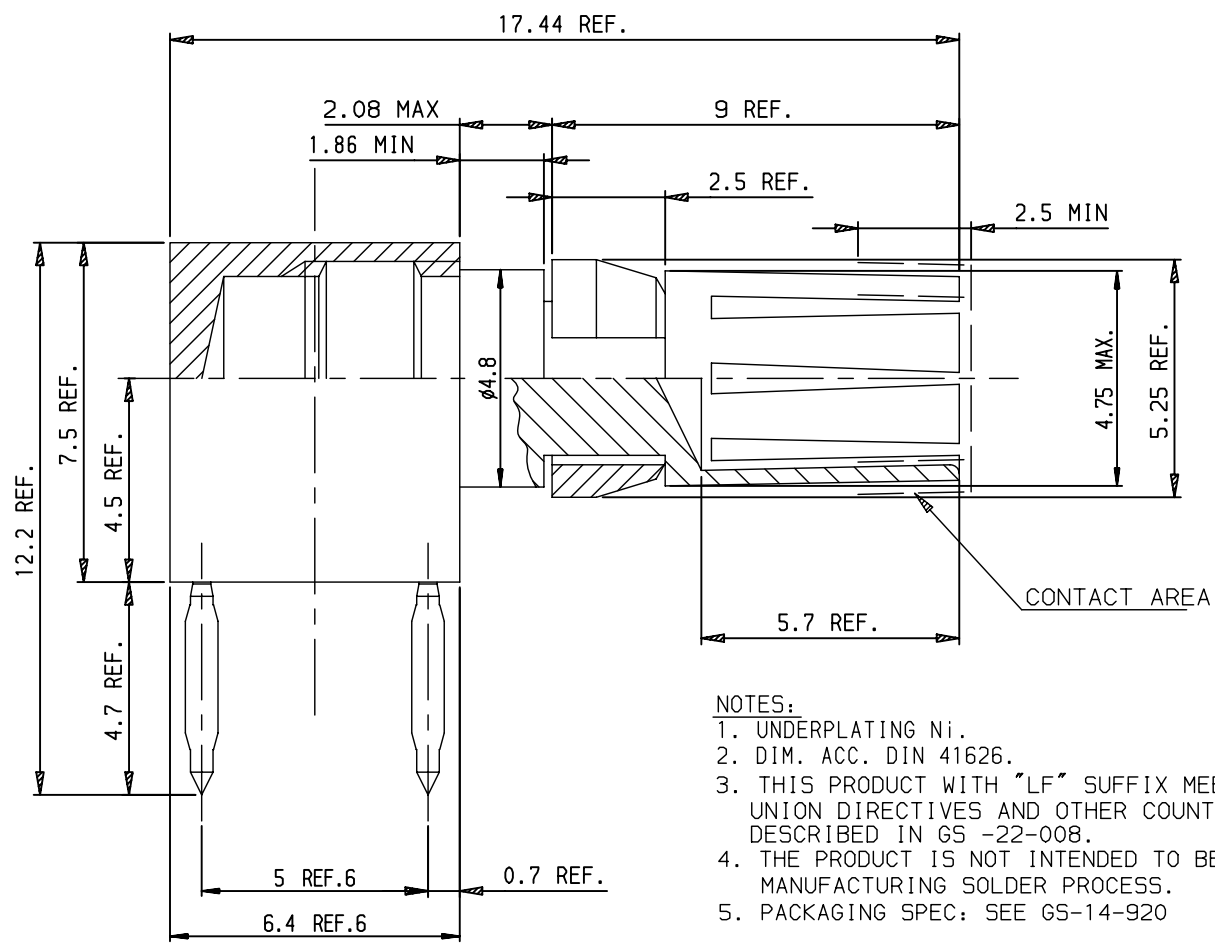

- NOTES:
1. UNDERPLATING Ni.
 2. DIM. ACC. DIN 41626.
 3. THIS PRODUCT WITH "LF" SUFFIX MEETS EUROPEAN UNION DIRECTIVES AND OTHER COUNTRY REGULATIONS AS DESCRIBED IN GS -22-008.
 4. THE PRODUCT IS NOT INTENDED TO BE EXPOSED TO A MANUFACTURING SOLDER PROCESS.
 5. PACKAGING SPEC: SEE GS-14-920

European Views

www.fciconnect.com		surface ISO 1302 ✓	tolerance std ISO 406 ISO 1101	projection mm
TOLERANCES UNLESS OTHERWISE SPECIFIED				
Dr	GOISNARD	2006/03/06	ANGULAR	size A3
Eng	GOISNARD	2006/03/06	LINEAR	Scale 9
Chr	LEGARE	2006/03/06	0.XX ±0.1	ECN LS08-0057
Appr	LEGARE	2006/03/06	0.XXX ±0.1	Spec ref -
Product family			METRAL	
		POWER INSERT RECEPTACLE RA STB		dwg no 85995
catalog no		-		Rev. G
CUSTOMER			sheet 2 of 2	

REV F - 2006-04-17

Copyright FCj.