

FEATURES

- Four programmable output voltages**
10.000 V, 7.500 V, 5.000 V, and 2.500 V
- Laser-trimmed to high accuracies**
- No external components required**
- Trimmed temperature coefficient**
15 ppm/°C maximum, 0°C to 70°C (AD584K)
15 ppm/°C maximum, -55°C to +125°C (AD584T)
- Zero output strobe terminal provided**
- 2-terminal negative reference: capability (5 V and above)**
- Output sources or sinks current**
- Low quiescent current: 1.0 mA maximum**
- 10 mA current output capability**
- MIL-STD-883 compliant versions available**

GENERAL DESCRIPTION

The AD584 is an 8-terminal precision voltage reference offering pin programmable selection of four popular output voltages: 10.000 V, 7.500 V, 5.000 V and 2.500 V. Other output voltages, above, below, or between the four standard outputs, are available by the addition of external resistors. The input voltage can vary between 4.5 V and 30 V.

Laser wafer trimming (LWT) is used to adjust the pin programmable output levels and temperature coefficients, resulting in the most flexible high precision voltage reference available in monolithic form.

In addition to the programmable output voltages, the AD584 offers a unique strobe terminal that permits the device to be turned on or off. When the AD584 is used as a power supply reference, the supply can be switched off with a single, low power signal. In the off state, the current drained by the AD584 is reduced to approximately 100 μ A. In the on state, the total supply current is typically 750 μ A, including the output buffer amplifier.

The AD584 is recommended for use as a reference for 8-, 10-, or 12-bit digital-to-analog converters (DACs) that require an external precision reference. In addition, the device is ideal for analog-to-digital converters (ADCs) of up to 14-bit accuracy, either successive approximation or integrating designs, and in general, it can offer better performance than that provided by standard self-contained references.

Rev. C

Information furnished by Analog Devices is believed to be accurate and reliable. However, no responsibility is assumed by Analog Devices for its use, nor for any infringements of patents or other rights of third parties that may result from its use. Specifications subject to change without notice. No license is granted by implication or otherwise under any patent or patent rights of Analog Devices. Trademarks and registered trademarks are the property of their respective owners.

PIN CONFIGURATIONS

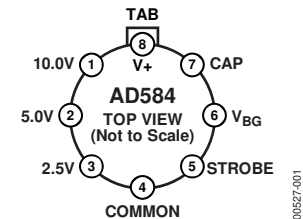

Figure 1. 8-Pin TO-99

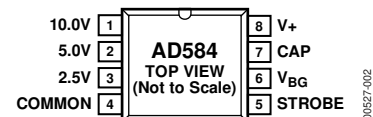

Figure 2. 8-Lead PDIP

The AD584J and AD584K are specified for operation from 0°C to +70°C, and the AD584S and AD584T are specified for the -55°C to +125°C range. All grades are packaged in a hermetically sealed, eight-terminal TO-99 metal can, and the AD584J and AD584K are also available in an 8-lead PDIP.

PRODUCT HIGHLIGHTS

1. The flexibility of the AD584 eliminates the need to design-in and inventory several different voltage references. Furthermore, one AD584 can serve as several references simultaneously when buffered properly.
2. Laser trimming of both initial accuracy and temperature coefficient results in very low errors overtemperature without the use of external components.
3. The AD584 can be operated in a 2-terminal Zener mode at a 5 V output and above. By connecting the input and the output, the AD584 can be used in this Zener configuration as a negative reference.
4. The output of the AD584 is configured to sink or source currents. This means that small reverse currents can be tolerated in circuits using the AD584 without damage to the reference and without disturbing the output voltage (10 V, 7.5 V, and 5 V outputs).
5. The AD584 is available in versions compliant with MIL-STD-883. Refer to the Analog Devices current AD584/883B data sheet for detailed specifications. This can be found under the **Additional Data Sheets** section of the AD584 product page.

TABLE OF CONTENTS

Features	1	Output Current Characteristics.....	7
Pin Configurations	1	Dynamic Performance.....	7
General Description	1	Noise Filtering	8
Product Highlights	1	Using the Strobe Terminal	8
Revision History	2	Precision High Current Supply.....	8
Specifications.....	3	The AD584 as a Current Limiter.....	9
Absolute Maximum Ratings.....	5	Negative Reference Voltages from an AD584	9
ESD Caution.....	5	10 V Reference with Multiplying CMOS DACs or ADCs.....	9
Theory of Operation	6	Precision DAC Reference	10
Applying the AD584	6	Outline Dimensions	11
Performance over Temperature	7	Ordering Guide	12

REVISION HISTORY

5/12—Rev. B to Rev. C

Deleted AD584L	Universal
Changes to Features Section, General Description Section and Product Highlights Section	1
Deleted Metalization Photograph	4
Changes to 10 V Reference with Multiplying CMOS DACs or ADCs Section.....	9
Changes to Precision DAC Reference Section and Figure 19...	10
Updated Outline Dimensions	11
Changes to Ordering Guide	12

7/01—Rev. A to Rev. B

SPECIFICATIONS

$V_{IN} = 15\text{ V}$ and 25°C , unless otherwise noted.

Specifications shown in **boldface** are tested on all production units at final electrical test. Results from those tests are used to calculate outgoing quality levels. All minimum and maximum specifications are guaranteed; although, only those shown in boldface are tested on all production units.

Table 1.

Model	AD584J			AD584K			Unit
	Min	Typ	Max	Min	Typ	Max	
OUTPUT VOLTAGE TOLERANCE							
Maximum Error at Pin 1 for Nominal Outputs of							
10.000 V			±30			±10	mV
7.500 V			±20			±8	mV
5.000 V			±15			±6	mV
2.500 V			±7.5			±3.5	mV
OUTPUT VOLTAGE CHANGE							
Maximum Deviation from 25°C Value, T_{MIN} to T_{MAX} ¹							
10.000 V, 7.500 V, and 5.000 V Outputs			30			15	ppm/ $^{\circ}\text{C}$
2.500 V Output			30			15	ppm/ $^{\circ}\text{C}$
Differential Temperature Coefficients Between Outputs	5			3			ppm/ $^{\circ}\text{C}$
QUIESCENT CURRENT	0.75		1.0	0.75		1.0	mA
Temperature Variation	1.5			1.5			$\mu\text{A}/^{\circ}\text{C}$
TURN-ON SETTLING TIME TO 0.1%	200			200			μs
NOISE (0.1 Hz TO 10 Hz)	50			50			$\mu\text{V p-p}$
LONG-TERM STABILITY	25			25			ppm/1000 Hrs
SHORT-CIRCUIT CURRENT	30			30			mA
LINE REGULATION (NO LOAD)							
$15\text{ V} \leq V_{IN} \leq 30\text{ V}$			0.002			0.002	%/V
$(V_{OUT} + 2.5\text{ V}) \leq V_{IN} \leq 15\text{ V}$			0.005			0.005	%/V
LOAD REGULATION							
$0 \leq I_{OUT} \leq 5\text{ mA}$, All Outputs	20		50	20		50	ppm/mA
OUTPUT CURRENT							
$V_{IN} \geq V_{OUT} + 2.5\text{ V}$							
Source at 25°C	10			10			mA
Source T_{MIN} to T_{MAX}	5			5			mA
Sink T_{MIN} to T_{MAX}	5			5			mA
TEMPERATURE RANGE							
Operating	0		70	0		70	$^{\circ}\text{C}$
Storage	-65		+175	-65		+175	$^{\circ}\text{C}$
PACKAGE OPTION							
8-Pin Metal Header (TO-99, H-08)			AD584JH			AD584KH	
8-Lead Plastic Dual In-Line Package (PDIP, N-8)			AD584JN			AD584KN	

¹ Calculated as average over the operating temperature range.

Specifications shown in **boldface** are tested on all production units at final electrical test. Results from those tests are used to calculate outgoing quality levels. All minimum and maximum specifications are guaranteed; although, only those shown in boldface are tested on all production units.

Table 2.

Model	AD584S			AD584T			Unit
	Min	Typ	Max	Min	Typ	Max	
OUTPUT VOLTAGE TOLERANCE							
Maximum Error at Pin 1 for Nominal Outputs of							
10.000 V			±30			±10	mV
7.500 V			±20			±8	mV
5.000 V			±15			±6	mV
2.500 V			±7.5			±3.5	mV
OUTPUT VOLTAGE CHANGE							
Maximum Deviation from 25°C Value, T _{MIN} to T _{MAX} ¹							
10.000 V, 7.500 V, and 5.000 V Outputs			30			15	ppm/°C
2.500 V Output			30			20	ppm/°C
Differential Temperature Coefficients Between Outputs		5			3		ppm/°C
QUIESCENT CURRENT		0.75	1.0		0.75	1.0	mA
Temperature Variation		1.5			1.5		µA/°C
TURN-ON SETTling TIME TO 0.1%		200			200		µs
NOISE (0.1 Hz TO 10 Hz)		50			50		µV p-p
LONG-TERM STABILITY		25			25		ppm/1000 Hrs
SHORT-CIRCUIT CURRENT		30			30		mA
LINE REGULATION (NO LOAD)							
15 V ≤ V _{IN} ≤ 30 V			0.002			0.002	%/V
(V _{OUT} + 2.5 V) ≤ V _{IN} ≤ 15 V			0.005			0.005	%/V
LOAD REGULATION							
0 ≤ I _{OUT} ≤ 5 mA, All Outputs		20	50		20	50	ppm/mA
OUTPUT CURRENT							
V _{IN} ≥ V _{OUT} + 2.5 V							
Source at 25°C	10			10			mA
Source T _{MIN} to T _{MAX}	5			5			mA
Sink T _{MIN} to T _{MAX}	5			5			mA
TEMPERATURE RANGE							
Operating	-55		+125	-55		+125	°C
Storage	-65		+175	-65		+175	°C
PACKAGE OPTION							
8-Pin Metal Header (TO-99, H-08)		AD584SH			AD584TH		

¹ Calculated as average over the operating temperature range.

ABSOLUTE MAXIMUM RATINGS

Table 3.

Parameter	Rating
Input Voltage V_{IN} to Ground	40 V
Power Dissipation at 25°C	600 mW
Operating Junction Temperature Range	-55°C to +125°C
Lead Temperature (Soldering 10 sec)	300°C
Thermal Resistance Junction-to-Ambient (H-08A)	150°C/W

Stresses above those listed under Absolute Maximum Ratings may cause permanent damage to the device. This is a stress rating only; functional operation of the device at these or any other conditions above those indicated in the operational section of this specification is not implied. Exposure to absolute maximum rating conditions for extended periods may affect device reliability.

ESD CAUTION



ESD (electrostatic discharge) sensitive device. Charged devices and circuit boards can discharge without detection. Although this product features patented or proprietary protection circuitry, damage may occur on devices subjected to high energy ESD. Therefore, proper ESD precautions should be taken to avoid performance degradation or loss of functionality.

THEORY OF OPERATION

APPLYING THE AD584

With power applied to Pin 8 and Pin 4 and all other pins open, the AD584 produces a buffered nominal 10.0 V output between Pin 1 and Pin 4 (see Figure 3). The stabilized output voltage can be reduced to 7.5 V, 5.0 V, or 2.5 V by connecting the programming pins as shown in Table 4.

Table 4.

Output Voltage (V)	Pin Programming
7.5	Join the 2.5 V (Pin 3) and 5.0 V (Pin 2) pins.
5.0	Connect the 5.0 V pin (Pin 2) to the output pin (Pin 1).
2.5	Connect the 2.5 V pin (Pin 3) to the output pin (Pin 1).

The options shown in Table 4 are available without the use of any additional components. Multiple outputs using only one AD584 can be provided by buffering each voltage programming pin with a unity-gain, noninverting op amp.

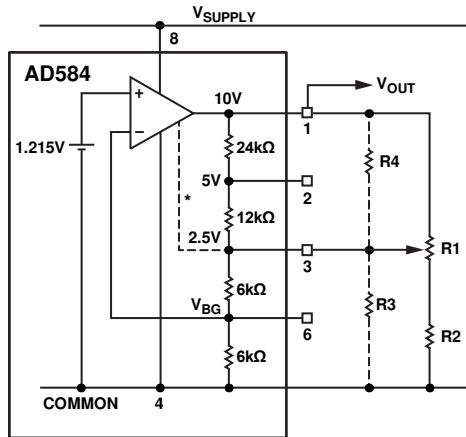

*THE 2.5V TAP IS USED INTERNALLY AS A BIAS POINT AND SHOULD NOT BE CHANGED BY MORE THAN 100mV IN ANY TRIM CONFIGURATION.

Figure 3. Variable Output Options

The AD584 can also be programmed over a wide range of output voltages, including voltages greater than 10 V, by the addition of one or more external resistors. Figure 3 illustrates the general adjustment procedure, with approximate values given for the internal resistors of the AD584. The AD584 may be modeled as an op amp with a noninverting feedback connection, driven by a high stability 1.215 V band gap reference (see Figure 5 for schematic).

When the feedback ratio is adjusted with external resistors, the output amplifier can be made to multiply the reference voltage by almost any convenient amount, making popular outputs of 10.24 V, 5.12 V, 2.56 V, or 6.3 V easy to obtain. The most general adjustment (which gives the greatest range and poorest resolution) uses R1 and R2 alone (see Figure 3). As R1 is adjusted to its upper limit, the 2.5V pin (Pin 3) is connected to the output, which reduces to 2.5 V. As R1 is adjusted to its lower limit, the output voltage rises to a value limited by R2. For example, if R2 is approximately 6 kΩ, the upper limit of the output range is

approximately 20 V, even for the large values of R1. Do not omit R2; choose its value to limit the output to a value that can be tolerated by the load circuits. If R2 is zero, adjusting R1 to its lower limit results in a loss of control over the output voltage. When precision voltages are set at levels other than the standard outputs, account for the 20% absolute tolerance in the internal resistor ladder.

Alternatively, the output voltage can be raised by loading the 2.5 V tap with R3 alone. The output voltage can be lowered by connecting R4 alone. Either of these resistors can be a fixed resistor selected by test or an adjustable resistor. In all cases, the resistors should have a low temperature coefficient to match the AD584 internal resistors, which have a negative temperature coefficient less than 60 ppm/°C. If both R3 and R4 are used, these resistors should have matching temperature coefficients.

When only small adjustments or trims are required, the circuit in Figure 4 offers better resolution over a limited trim range. The circuit can be programmed to 5.0 V, 7.5 V, or 10 V, and it can be adjusted by means of R1 over a range of about ±200 mV. To trim the 2.5 V output option, R2 (see Figure 4) can be reconnected to the band gap reference (Pin 6). In this configuration, limit the adjustment to ±100 mV to avoid affecting the performance of the AD584.

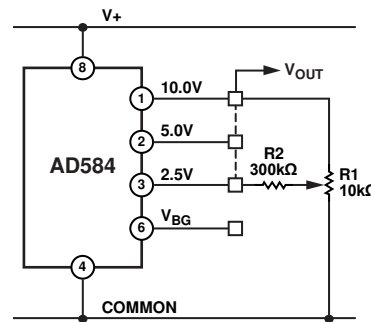

Figure 4. Output Trimming

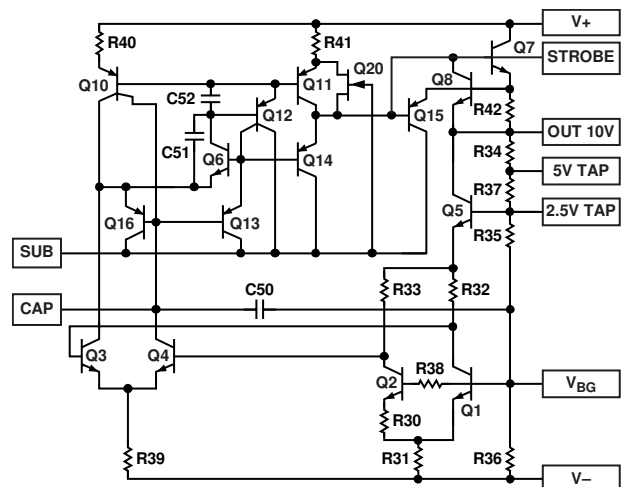

Figure 5. Schematic Diagram

PERFORMANCE OVER TEMPERATURE

Each AD584 is tested at three temperatures over the -55°C to $+125^{\circ}\text{C}$ range to ensure that each device falls within the maximum error band (see Figure 6) specified for a particular grade (that is, S and T grades); three-point measurement guarantees performance within the error band from 0°C to 70°C (that is, J and K grades). The error band guaranteed for the AD584 is the maximum deviation from the initial value at 25°C . Thus, given the grade of the AD584, the maximum total error from the initial tolerance plus the temperature variation can easily be determined. For example, for the AD584T, the initial tolerance is $\pm 10\text{ mV}$, and the error band is $\pm 15\text{ mV}$. Therefore, the unit is guaranteed to be $10.000\text{ V} \pm 25\text{ mV}$ from -55°C to $+125^{\circ}\text{C}$.

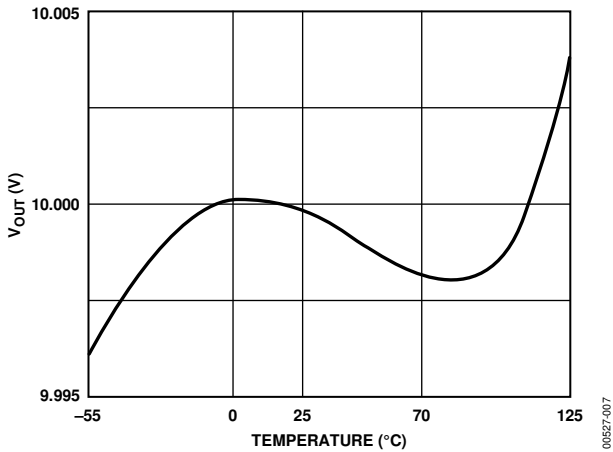

Figure 6. Typical Temperature Characteristic

OUTPUT CURRENT CHARACTERISTICS

The AD584 has the capability to either source or sink current and provide good load regulation in either direction; although, it has better characteristics in the source mode (positive current into the load). The circuit is protected for shorts to either positive

supply or ground. Figure 7 shows the output voltage vs. the output current characteristics of the device. Source current is displayed as negative current in the figure, and sink current is displayed as positive current. The short-circuit current (that is, 0 V output) is about 28 mA; however, when shorted to 15 V, the sink current goes to approximately 20 mA.

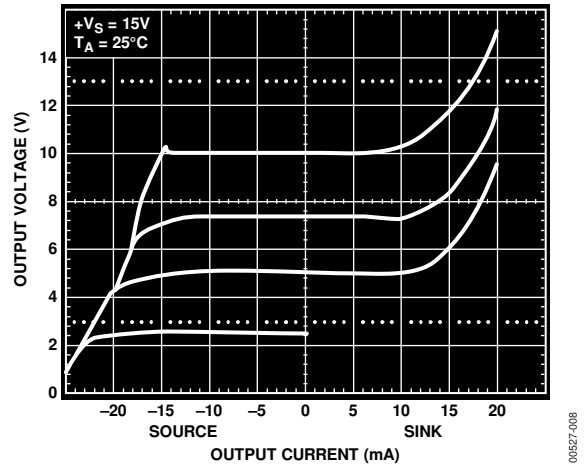

Figure 7. Output Voltage vs. Output Current (Sink and Source)

DYNAMIC PERFORMANCE

Many low power instrument manufacturers are becoming increasingly concerned with the turn-on characteristics of the components being used in their systems. Fast turn-on components often enable the end user to keep power off when not needed and yet respond quickly when the power is turned on. Figure 8 displays the turn-on characteristic of the AD584. Figure 8 is generated from cold-start operation and represents the true turn-on waveform after an extended period with the supplies off. Figure 8 shows both the coarse and fine transient characteristics of the device; the total settling time to within $\pm 10\text{ mV}$ is about $180\text{ }\mu\text{s}$, and there is no long thermal tail appearing after the point.

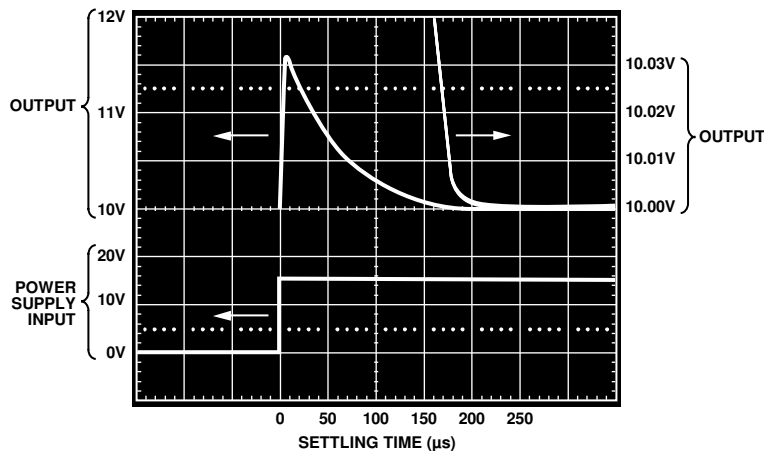

Figure 8. Output Settling Characteristic

NOISE FILTERING

The bandwidth of the output amplifier in the AD584 can be reduced to filter output noise. A capacitor ranging between 0.01 μF and 0.1 μF connected between the CAP and V_{BG} terminals further reduces the wideband and feedthrough noise in the output of the AD584, as shown in Figure 9 and Figure 10. However, this tends to increase the turn-on settling time of the device; therefore, allow for ample warm-up time.

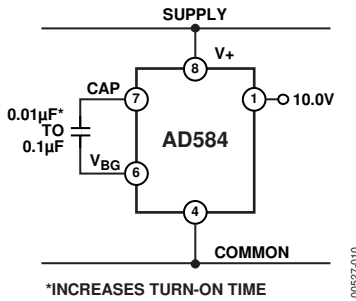

Figure 9. Additional Noise Filtering with an External Capacitor

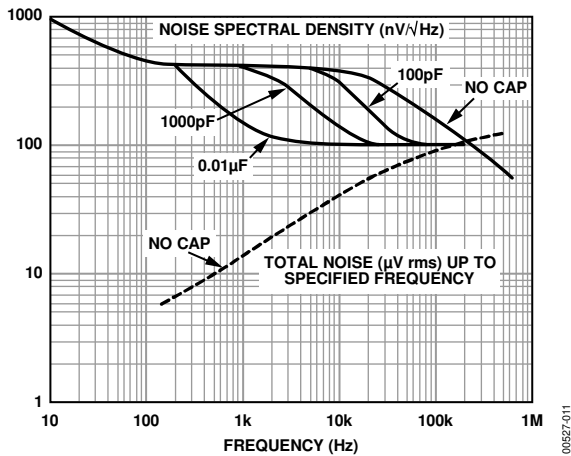

Figure 10. Spectral Noise Density and Total RMS Noise vs. Frequency

USING THE STROBE TERMINAL

The AD584 has a strobe input that can be used to zero the output. This unique feature permits a variety of new applications in signal and power conditioning circuits.

Figure 11 illustrates the strobe connection. A simple NPN switch can be used to translate a TTL logic signal into a strobe of the output. The AD584 operates normally when there is no current drawn from Pin 5. Bringing this terminal low, to less than 200 mV, allows the output voltage to go to zero. In this mode, the AD584 is not required to source or sink current (unless a 0.7 V residual output is permissible). If the AD584 is required to sink a transient current while strobe is off, limit the strobe terminal input current by a 100 Ω resistor, as shown in Figure 11.

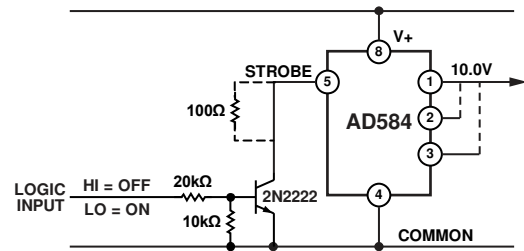

Figure 11. Use of the Strobe Terminal

The strobe terminal tolerates up to 5 μA leakage, and its driver should be capable of sinking 500 μA continuous. A low leakage, open collector gate can be used to drive the strobe terminal directly, provided the gate can withstand the AD584 output voltage plus 1 V.

PRECISION HIGH CURRENT SUPPLY

The AD584 can be easily connected to a power PNP or power PNP Darlington device to provide much greater output current capability. The circuit shown in Figure 12 delivers a precision 10 V output with up to 4 A supplied to the load. If the load has a significant capacitive component, the 0.1 μF capacitor is required. If the load is purely resistive, improved high frequency, supply rejection results from removing the capacitor.

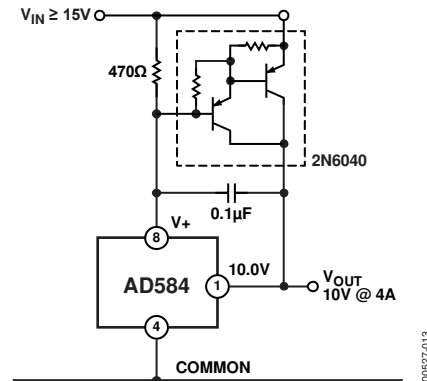

Figure 12. High Current Precision Supply

The AD584 can also use an NPN or NPN Darlington transistor to boost its output current. Simply connect the 10 V output terminal of the AD584 to the base of the NPN booster and take the output from the booster emitter, as shown in Figure 13. The 5.0V pin or the 2.5V pin must connect to the actual output in this configuration. Variable or adjustable outputs (as shown in Figure 3 and Figure 4) can be combined with a 5.0 V connection to obtain outputs above 5.0 V.

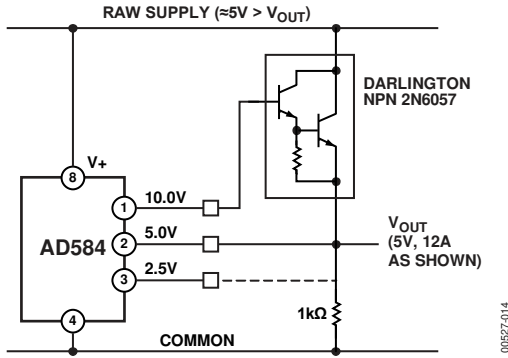

Figure 13. NPN Output Current Booster

THE AD584 AS A CURRENT LIMITER

The AD584 represents an alternative to current limiter diodes that require factory selection to achieve a desired current. Use of current limiting diodes often results in temperature coefficients of 1%/°C. Use of the AD584 in this mode is not limited to a set current limit; it can be programmed from 0.75 mA to 5 mA with the insertion of a single external resistor (see Figure 14). The minimum voltage required to drive the connection is 5 V.

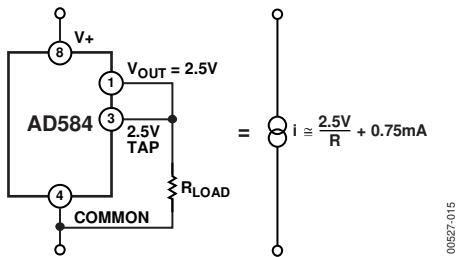

Figure 14. A Two-Component Precision Current Limiter

NEGATIVE REFERENCE VOLTAGES FROM AN AD584

The AD584 can also be used in a 2-terminal Zener mode to provide a precision -10 V, -7.5 V, or -5.0 V reference. As shown in Figure 15, the VIN and VOUT terminals are connected together to the positive supply (in this case, ground). The AD584 COMMON pin is connected through a resistor to the negative supply. The output is now taken from the COMMON pin instead of VOUT. With 1 mA flowing through the AD584 in this mode, a typical unit shows a 2 mV increase in the output level over that produced in 3-terminal mode. Also, note that the effective output impedance in this connection increases from 0.2 Ω typical to 2 Ω. It is essential to arrange the output load and the supply resistor, Rs, so that the net current through the AD584 is always between 1 mA and 5 mA (between 2 mA and 5 mA for operation beyond 85°C).

The temperature characteristics and long-term stability of the device is essentially the same as that of a unit used in standard 3-terminal mode.

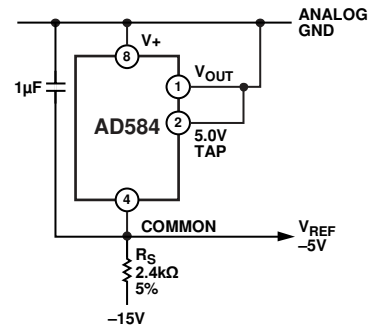

Figure 15. 2-Terminal, -5 V Reference

The AD584 can also be used in 2-terminal mode to develop a positive reference. VIN and VOUT are tied together and to the positive supply through an appropriate supply resistor. The performance characteristics are similar to those of a negative 2-terminal connection. The only advantage of this connection over the standard 3-terminal connection is that a lower primary supply can be used, as low as 0.5 V above the desired output voltage. This type of operation requires considerable attention to load and to the primary supply regulation to ensure that the AD584 always remains within its regulating range of 1 mA to 5 mA (2 mA to 5 mA for operation beyond 85°C).

10 V REFERENCE WITH MULTIPLYING CMOS DACs OR ADCs

The AD584 is ideal for application with the AD7533 10-bit multiplying CMOS DAC, especially for low power applications. It is equally suitable for the AD7574 8-bit ADC. In the standard hook-up, as shown in Figure 16, the standard output voltages are inverted by the amplifier/DAC configuration to produce converted voltage ranges. For example, a +10 V reference produces a 0 V to -10 V range. If an OP1177 amplifier is used, total quiescent supply current is typically 2 mA.

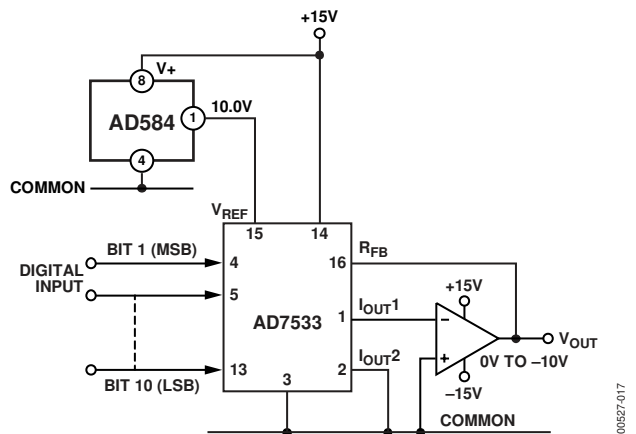
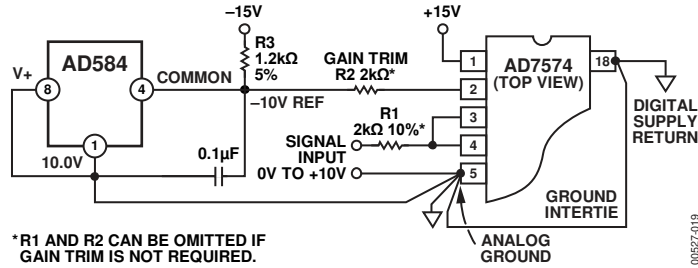

Figure 16. Low Power 10-Bit CMOS DAC Application

The AD584 is normally used in the -10 V mode with the AD7574 to give a 0 V to +10 V ADC range. This is shown in Figure 17. Bipolar output applications and other operating details can be found in the data sheets for the CMOS products.



*R1 AND R2 CAN BE OMITTED IF GAIN TRIM IS NOT REQUIRED.

Figure 17. AD584 as -10 V Reference for CMOS ADC

PRECISION DAC REFERENCE

The AD565A, like many DACs, can operate with an external 10 V reference element (see Figure 19). This 10 V reference voltage is converted into a reference current of approximately 0.5 mA via the internal 19.95 kΩ resistor (in series with the external 100 Ω trimmer). The gain temperature coefficient of the AD565A is primarily governed by the temperature tracking of the 19.95 kΩ resistor and the 5 kΩ/10 kΩ span resistors; this gain temperature coefficient is guaranteed to 3 ppm/°C. Therefore, using the AD584K (at 5 ppm/°C) as the 10 V reference guarantees a maximum full-

scale temperature coefficient of 18 ppm/°C more than the commercial range. The 10 V reference also supplies the normal 1 mA bipolar offset current through the 9.95 kΩ bipolar offset resistor. The bipolar offset temperature coefficient thus depends only on the temperature coefficient matching of the bipolar offset resistor to the input reference resistor and is guaranteed to 3 ppm/°C. Figure 18 demonstrates the flexibility of the AD584 applied to another popular digital-to-analog configuration.

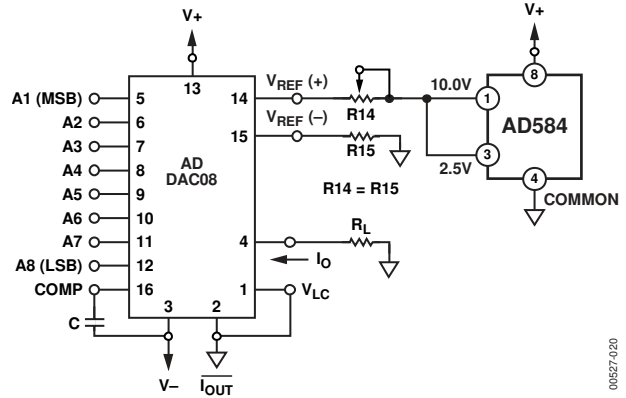

Figure 18. Current Output, 8-Bit Digital-to-Analog Configuration

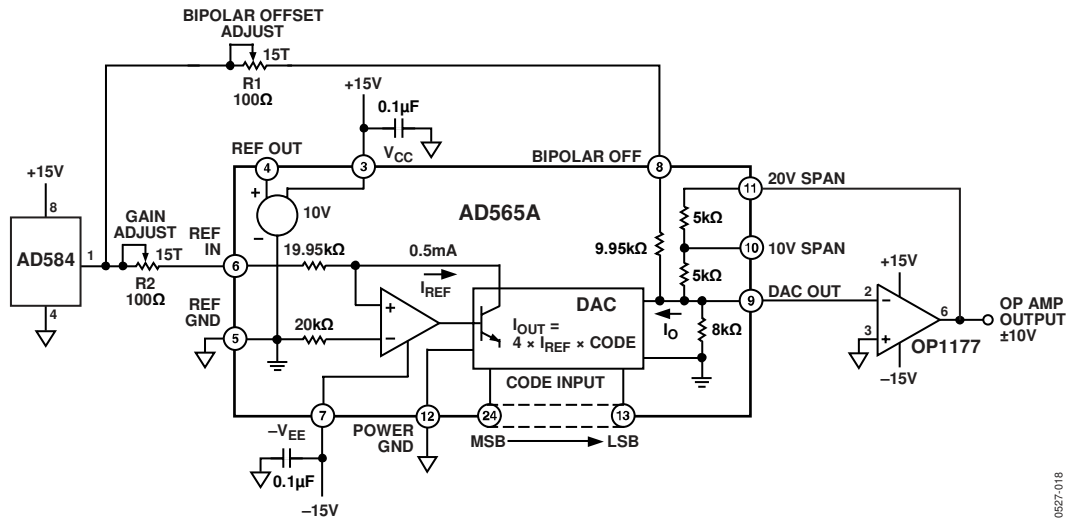
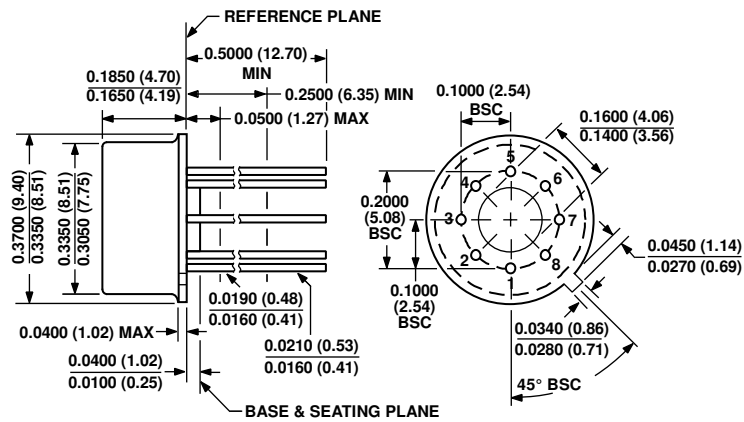

Figure 19. Precision 12-Bit DAC

OUTLINE DIMENSIONS



COMPLIANT TO JEDEC STANDARDS MO-002-AK
 CONTROLLING DIMENSIONS ARE IN INCHES; MILLIMETER DIMENSIONS
 (IN PARENTHESES) ARE ROUNDED-OFF INCH EQUIVALENTS FOR
 REFERENCE ONLY AND ARE NOT APPROPRIATE FOR USE IN DESIGN.

Figure 20. 8-Pin Metal Header [TO-99]
 (H-08)

Dimensions shown in inches and (millimeters)

022306-A

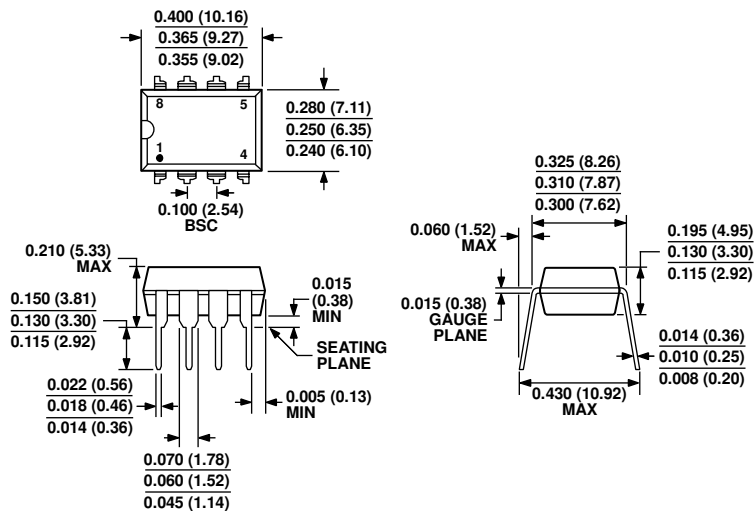

COMPLIANT TO JEDEC STANDARDS MS-001
 CONTROLLING DIMENSIONS ARE IN INCHES; MILLIMETER DIMENSIONS
 (IN PARENTHESES) ARE ROUNDED-OFF INCH EQUIVALENTS FOR
 REFERENCE ONLY AND ARE NOT APPROPRIATE FOR USE IN DESIGN.
 CORNER LEADS MAY BE CONFIGURED AS WHOLE OR HALF LEADS.

Figure 21. 8-Lead Plastic Dual In-Line Package [PDIP]
 Narrow Body (N-8)

Dimensions shown in inches and (millimeters)

070606-A

ORDERING GUIDE

Model ¹	Output Voltage (V _o)	Initial Accuracy		Temperature Coefficient (ppm/°C)	Temperature Range (°C)	Package Description	Package Option	Ordering Quantity
		mV	%					
AD584JH	2.5	±7.5	0.30	30	0 to 70	8-Pin TO-99	H-08	100
AD584JNZ	2.5	±7.5	0.30	30	0 to 70	8-Lead PDIP	N-8	50
AD584KH	2.5	±3.5	0.14	15	0 to 70	8-Pin TO-99	H-08	100
AD584KNZ	2.5	±3.5	0.14	15	0 to 70	8-Lead PDIP	N-8	50
AD584SH	2.5	±7.5	0.30	30	-55 to +125	8-Pin TO-99	H-08	100
AD584SH/883B	2.5	±7.5	0.30	30	-55 to +125	8-Pin TO-99	H-08	100
AD584TH	2.5	±3.5	0.14	20	-55 to +125	8-Pin TO-99	H-08	100
AD584TH/883B	2.5	±3.5	0.14	20	-55 to +125	8-Pin TO-99	H-08	100
AD584JH	5.0	±15.0	0.30	30	0 to 70	8-Pin TO-99	H-08	100
AD584JNZ	5.0	±15.0	0.30	30	0 to 70	8-Lead PDIP	N-8	50
AD584KH	5.0	±6.0	0.12	15	0 to 70	8-Pin TO-99	H-08	100
AD584KNZ	5.0	±6.0	0.12	15	0 to 70	8-Lead PDIP	N-8	50
AD584SH	5.0	±15.0	0.14	30	-55 to +125	8-Pin TO-99	H-08	100
AD584SH/883B	5.0	±15.0	0.30	30	-55 to +125	8-Pin TO-99	H-08	100
AD584TH	5.0	±6.0	0.30	15	-55 to +125	8-Pin TO-99	H-08	100
AD584TH/883B	5.0	±6.0	0.12	15	-55 to +125	8-Pin TO-99	H-08	100
AD584JH	7.5	±20.0	0.27	30	0 to 70	8-Pin TO-99	H-08	100
AD584JNZ	7.5	±20.0	0.27	30	0 to 70	8-Lead PDIP	N-8	50
AD584KH	7.5	±8.0	0.11	15	0 to 70	8-Pin TO-99	H-08	100
AD584KNZ	7.5	±8.0	0.11	15	0 to 70	8-Lead PDIP	N-8	50
AD584SH	7.5	±20.0	0.27	30	-55 to +125	8-Pin TO-99	H-08	100
AD584SH/883B	7.5	±20.0	0.27	30	-55 to +125	8-Pin TO-99	H-08	100
AD584TH	7.5	±8.0	0.11	15	-55 to +125	8-Pin TO-99	H-08	100
AD584TH/883B	7.5	±8.0	0.11	15	-55 to +125	8-Pin TO-99	H-08	100
AD584JH	10.0	±30.0	0.30	30	0 to 70	8-Pin TO-99	H-08	100
AD584JNZ	10.0	±30.0	0.30	30	0 to 70	8-Lead PDIP	N-8	50
AD584KH	10.0	±10.0	0.10	15	0 to 70	8-Pin TO-99	H-08	100
AD584KNZ	10.0	±10.0	0.10	15	0 to 70	8-Lead PDIP	N-8	50
AD584SH	10.0	±30.0	0.30	30	-55 to +125	8-Pin TO-99	H-08	100
AD584SH/883B	10.0	±30.0	0.30	30	-55 to +125	8-Pin TO-99	H-08	100
AD584TH	10.0	±10.0	0.10	15	-55 to +125	8-Pin TO-99	H-08	100
AD584TH/883B	10.0	±10.0	0.10	15	-55 to +125	8-Pin TO-99	H-08	100

¹ Z = RoHS Compliant Part.