

PRODUCT NUMBER
SEE TABLE

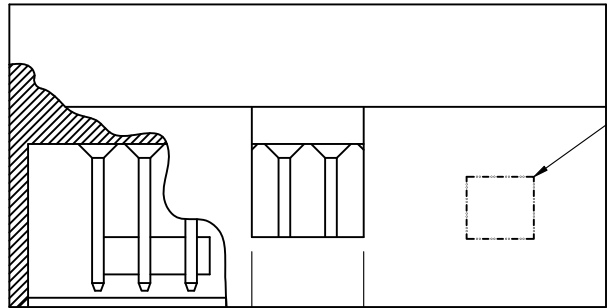

Φ W $\text{\textcircled{S}}$.060/1.52 $\text{\textcircled{S}}$

NOTE 5

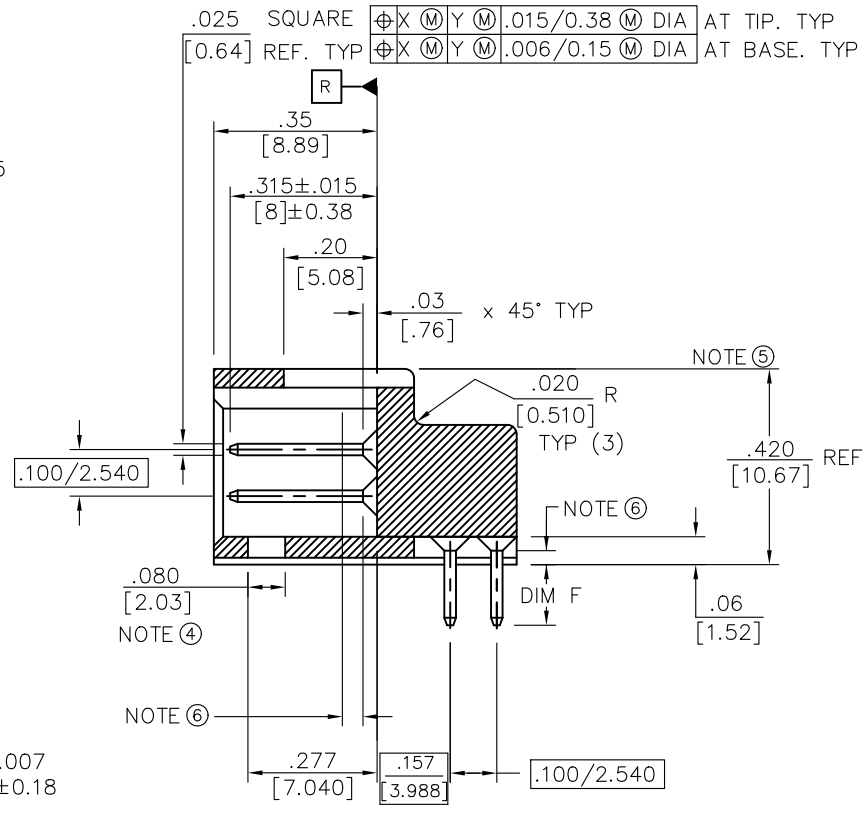

SECTION H-H

Φ X $\text{\textcircled{M}}$ Y $\text{\textcircled{M}}$.015/0.38 $\text{\textcircled{M}}$ DIA AT TIP. TYP
 Φ X $\text{\textcircled{M}}$ Y $\text{\textcircled{M}}$.006/0.15 $\text{\textcircled{M}}$ DIA AT BASE. TYP

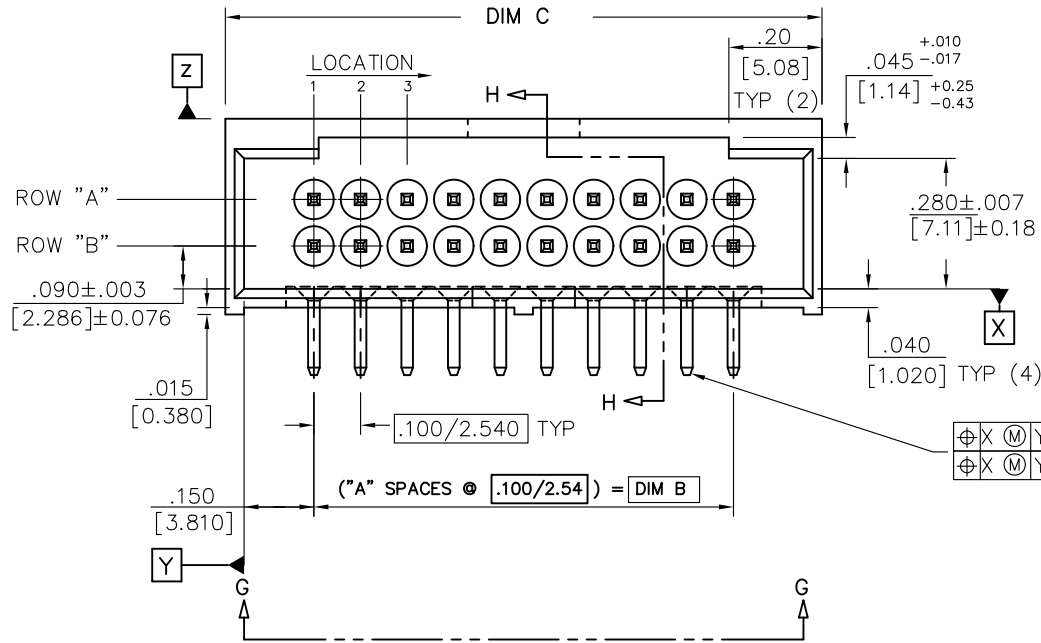

Z

Y

X

Amphenol
FCI

© 2016 AFCI

mat'l. code		surface ISO 1302 <input checked="" type="checkbox"/>		tolerance ISO 406 <input checked="" type="checkbox"/>		projection		product family BERGSTIK	
Itr ecn no dr date		tolerances unless otherwise specified		angles linear		MM		title	
C	M05-0204	MHT	11/09/05	.XX±.01/.X±.3		scale 1:1		RIGHT ANGLE HEADER FOR FLAT CABLE RECEPTACLE	
D	N07-0150	MHT	8/01/07	.XXX±.005/.XX±.13				dwg no 68645 sheet 1 of 4 size A3	
E	ELX-N-13900	DCS	13-01-22	.XXXX±.0020/.XXX±.051				type Product Customer Drawing	
F	ELX-N-32089	MZ	18/12/20	dr	COPENHEAVED	7/10/84	Amphenol FCI		
				enr	P.M. SMITH	4/10/85			
				chr	---	---			
				appd	CA WILLIAMS	4/12/85			
sheet index	revision sheet	F 1-4							

PRODUCT NUMBER

SEE TABLE

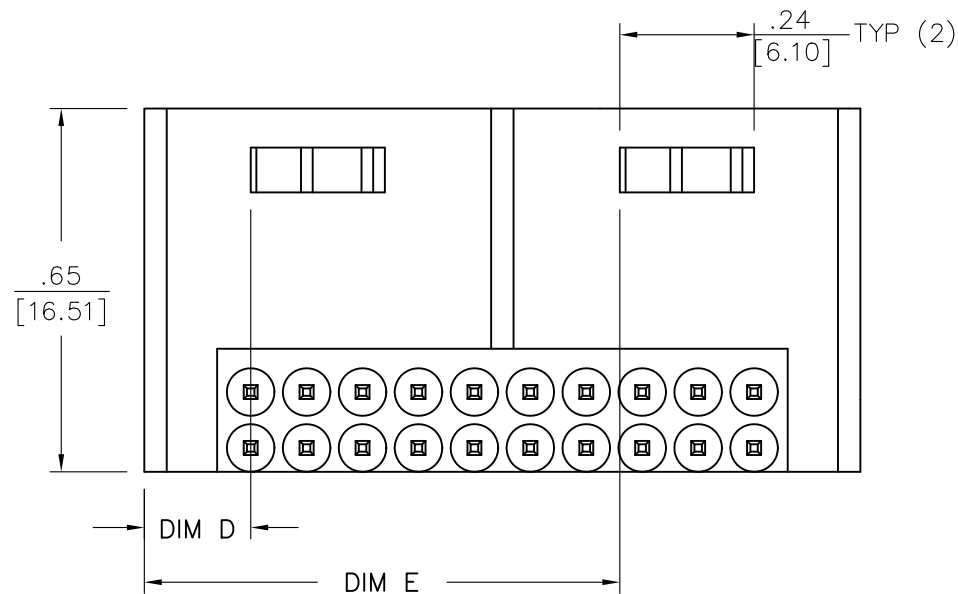

NOTES:

1. TERMINAL MAT'L: 3/4 HARD PHOS. BRONZE ALLOY UNS-C51000.
2. PLATING; (1) 0.76 μ m/30 μ " A μ OR GTX OVER 1.27 μ m/50 μ " Ni.
(2) 0.76 μ m/30 μ " A μ OVER 1.27 μ m/50 μ " Ni.
3. MOLDING MAT'L: GLASS FILLED POLYESTER. FLAME RETARDANT PER UL94V-0. COLOR BLACK
4. .02/0.51 MAX FLASH AROUND ALL WINDOWS.
5. FCI LOGO MOLDED IN ON DATUM SURFACE -Z- APPROXIMATELY AS SHOWN.
6. .03/.76 MAX FLASH PERMISSIBLE ON PINS BOTH ENDS.
7. OTHER PLATINGS ARE AVAILABLE ON 68420, 68646 AND 68647.
8. ADD "LF" AT THE END OF PART NUMBER FOR LEAD FREE OPTION.
9. THIS PRODUCT MEETS EUROPEAN UNION DIRECTIVES AND OTHER COUNTRY REGULATION AS DESCRIBED IN GS-22-008
10. THE HOUSING WILL WITHSTAND EXPOSURE TO 260°C PEAK TEMPERATURE FOR 15 SECONDS IN A WAVE SOLDER APPLICATION WITH A 1.5mm MINIMUM THICK CIRCUIT BOARD. SEE APPLICATION NOTES/PROCEDURES IF THEY ARE AVAILABLE.

Amphenol FCI

© 2016 AFCI

mat'l. code		surface ISO 1302 ✓		tolerance ISO 406 ISO 1101		projection 		product family BERGSTIK	
ltr		ecn no		dr		date		title	
F								RIGHT ANGLE HEADER FOR FLAT CABLE RECEPTACLE	
				tolerances unless otherwise specified		MM		scale 1:1	
		angles		linear				dwg no	
		0°±2'						sheet 2 of 4	
		dr		COPENHEAVED		7/10/84		size	
		enr		P.M. SMITH		4/10/85		A3	
		chr		---		---		68645	
		appd		CA WILLIAMS		4/12/85		type Product Customer Drawing	
sheet		revision							
index		sheet							

A
B
C
D

A
B
C
D

PRODUCT No. NOTE 9,10	No. OF POS.	"A" SPACES	DIM B	DIM C	DIM D	DIM E	DIM F	PLATING CODE
68645-001	6	2	.200/5.080	.500/12.700	.150/3.810	-----	.130/3.300	
-002	8	3	.300/7.620	.600/15.240	.150/3.810	-----	.130/3.300	
-003	10	4	.400/10.160	.700/17.780	.250/6.350	-----	.130/3.300	
-004	12	5	.500/12.700	.800/20.320	.250/6.350	-----	.130/3.300	
-005	14	6	.600/15.240	.900/22.860	.350/8.890	-----	.130/3.300	
-006	16	7	.700/17.780	1.000/25.400	.350/8.890	-----	.130/3.300	
-007	18	8	.800/20.320	1.100/27.940	.450/11.430	-----	.130/3.300	
-008	20	9	.900/22.860	1.200/30.480	.150/3.810	.850/21.590	.130/3.300	
-009	22	10	1.000/25.400	1.300/33.020	.150/3.810	.950/24.130	.130/3.300	
-010	24	11	1.100/27.940	1.400/35.560	.150/3.810	1.050/26.670	.130/3.300	
-011	26	12	1.200/30.480	1.500/38.100	.150/3.810	1.150/29.210	.130/3.300	
-012	28	13	1.300/33.020	1.600/40.640	.150/3.810	1.250/31.750	.130/3.300	
-013	30	14	1.400/35.560	1.700/43.180	.150/3.810	1.350/34.290	.130/3.300	
-014	32	15	1.500/38.100	1.800/45.720	.150/3.810	1.450/36.830	.130/3.300	
-015	34	16	1.600/40.640	1.900/48.260	.150/3.810	1.550/39.370	.130/3.300	
-016	36	17	1.700/43.180	2.000/50.800	.150/3.810	1.650/41.910	.130/3.300	
-017	38	18	1.800/45.720	2.100/53.340	.150/3.810	1.750/44.450	.130/3.300	
-018	40	19	1.900/48.260	2.200/55.880	.150/3.810	1.850/46.990	.130/3.300	
-019	42	20	2.000/50.800	2.300/58.420	.150/3.810	1.950/49.530	.130/3.300	
-020	44	21	2.100/53.340	2.400/60.960	.150/3.810	2.050/52.070	.130/3.300	
-021	46	22	2.200/55.880	2.500/63.500	.150/3.810	2.150/54.610	.130/3.300	
-022	48	23	2.300/58.420	2.600/66.040	.150/3.810	2.250/57.150	.130/3.300	
-023	50	24	2.400/60.960	2.700/68.580	.150/3.810	2.350/59.690	.130/3.300	
-024	52	25	2.500/63.500	2.800/71.120	.150/3.810	2.450/62.230	.130/3.300	
-025	54	26	2.600/66.040	2.900/73.660	.150/3.810	2.550/64.770	.130/3.300	
-026	56	27	2.700/68.580	3.000/76.200	.150/3.810	2.650/67.310	.130/3.300	
-027	58	28	2.800/71.120	3.100/78.740	.150/3.810	2.750/69.850	.130/3.300	
-028	60	29	2.900/73.660	3.200/81.280	.150/3.810	2.850/72.390	.130/3.300	
-029	62	30	3.000/76.200	3.300/83.820	.150/3.810	2.950/74.930	.130/3.300	
68645-030	64	31	3.100/78.740	3.400/86.360	.150/3.810	3.050/77.470	.130/3.300	

SEE NOTE 2
(1)



© 2016 AFCI

mat'l. code		surface ISO 1302 <input checked="" type="checkbox"/>		tolerance ISO 406 <input checked="" type="checkbox"/>		projection		product family BERGSTIK	
ltr		ecn no		dr		date		title	
F								RIGHT ANGLE HEADER FOR FLAT CABLE RECEPTACLE	
								MM	
								scale 1:1	
				dr		COPENHEAVED		7/10/84	
				enr		P.M. SMITH		4/10/85	
				chr		---		---	
				appd		CA WILLIAMS		4/12/85	
sheet		revision						dwg no	
index		sheet						sheet 3 of 4	
								68645	
								A3	
								type Product Customer Drawing	

PRODUCT No. NOTE 9,10	No. OF POS.	"A" SPACES	DIM B	DIM C	DIM D	DIM E	DIM F	PLATING CODE
68645-031	66	32	3.200/81.280	3.500/88.900	.150/3.810	3.150/80.010	.130/3.300	SEE NOTE 2 (1)
-032	68	33	3.300/83.820	3.600/91.440	.150/3.810	3.250/82.550	.130/3.300	
-033	70	34	3.400/86.360	3.700/93.980	.150/3.810	3.350/85.090	.130/3.300	
-034	72	35	3.500/88.900	3.800/96.520	.150/3.810	3.450/87.630	.130/3.300	
-035	16	7	.700/17.780	1.000/25.400	.350/8.890	-----	.155/3.940	
-036	40	19	1.900/48.260	2.200/55.880	.150/3.810	1.850/46.990	.155/3.940	
-037	50	24	2.400/60.960	2.700/68.580	.150/3.810	2.350/59.690	.155/3.940	
68645-038	I N A C T I V E							
68645-039	10	4	.400/10.160	.700/17.780	.250/6.350	-----	.130/3.300	SEE NOTE 2 (2)
68645-040	14	6	.600/15.240	.900/22.860	.350/8.890	-----	.130/3.300	
68645-041	20	9	.900/22.860	1.200/30.480	.150/3.810	.850/21.590	.130/3.300	
68645-042	26	12	1.200/30.480	1.500/38.100	.150/3.810	1.150/29.210	.130/3.300	
68645-043	34	16	1.600/40.640	1.900/48.260	.150/3.810	1.550/39.370	.130/3.300	
68645-044	50	24	2.400/60.960	2.700/68.580	.150/3.810	2.350/59.690	.130/3.300	
68645-045	16	7	.700/17.780	1.000/25.400	.350/8.890	-----	.130/3.300	
68645-046	24	11	1.100/27.940	1.400/35.560	.150/3.810	1.050/26.670	.130/3.300	
68645-047	32	15	1.500/38.100	1.800/45.720	.150/3.810	1.450/36.830	.130/3.300	
68645-048	60	29	2.900/73.660	3.200/81.280	.150/3.810	2.850/72.390	.130/3.300	
68645-050	40	19	1.900/48.260	2.200/55.880	.150/3.810	1.850/46.990	.130/3.300	
68645-051	26	12	1.200/30.480	1.500/38.10	.150/3.810	1.150/29.210	.205/5.21	
68645-052	34	16	1.600/40.640	1.900/48.260	.150/3.810	1.550/39.370	.205/5.21	

A
B
C
D
 © 2016 APCI
 Amphenol FCI

mat'l. code		surface ISO 1302 ✓		tolerance ISO 406 ISO 1101		projection 		product family BERGSTIK	
ltr	ecn no	dr	date	tolerances unless otherwise specified		title		sheet 4 of 4 size	
F				angles	linear	MM		RIGHT ANGLE HEADER FOR FLAT CABLE RECEPTACLE	
				0±.2		scale 1:1		dwg no 68645 A3	
				dr	COPENHEAVED	7/10/84		type Product Customer Drawing	
				enr	P.M. SMITH	4/10/85		Amphenol FCI	
				chr	---	---			
				appd	CA WILLIAMS	4/12/85			
sheet index	revision sheet								