

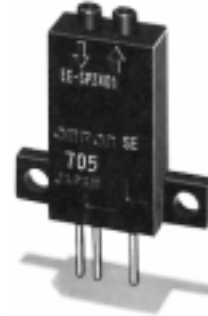

EE-SPZ301/401/W-01/W-02/Y-01

Fiber-Optic Sensing Head Fits Space-Confined Areas

- Light modulation effectively reduces external light interference
- Built-in amplifier with optical fiber
- Easy adjustment and optical axis monitoring with a Light-ON indicator
- Wide operating voltage range (5 to 24 VDC) makes smooth connection possible with a TTLs, relays, and programmable controllers (PLCs)
- Easy-to-wire connector assures ease of maintenance
- Convert to PNP output with EE-2001 conversion connector

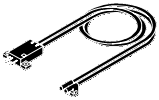

Ordering Information

Appearance	Sensing method	Sensing distance	Output configuration	Weight	Part number
	Transmissive (with lens)	30 mm	Dark-ON	Approx. 7.6 g	EE-SPZ301W-01
			Light-ON		EE-SPZ401W-01
	Transmissive (without lens)	5 mm	Dark-ON	Approx. 7.0 g	EE-SPZ301W-02
			Light-ON		EE-SPZ401W-02
	Reflective (with lens)	1 to 3 mm	Dark-ON	Approx. 7.2 g	EE-SPZ301Y-01
			Light-ON		EE-SPZ401Y-01

Specifications

■ RATINGS

Item	Transmissive (with lens)		Transmissive (without lens)		Reflective (with lens)		
	EE-SPZ301 W-01	EE-SPZ401 W-01	EE-SPZ301 W-02	EE-SPZ401 W-02	EE-SPZ301 Y-01	EE-SPZ401 Y-01	
Supply voltage	5 to 24 VDC $\pm 10\%$, ripple (p-p): 5% max.						
Current consumption	Average: 15 mA max.; Peak: 50 mA max.						
Sensing distance	30 mm		5 mm		1 to 3 mm (reflection factor: 90%; white paper 15 x 15 mm)		
Standard reference object	Opaque: 4 dia. min.		Opaque: 1 dia. min.		Transparent, opaque		
Differential distance	—		—		—		
Control output	At 5 to 24 VDC: 80-mA load current (I_C) with a residual voltage of 1.0 V max. When driving TTL: 10-mA load current (I_C) with a residual voltage of 0.4 V max.						
Output configuration	Transistor on output stage without detecting object	OFF	ON	OFF	ON	ON	OFF
	Transistor on output stage with detecting object	ON	OFF	ON	OFF	OFF	ON
Indicator*	Without detecting object	ON		ON		ON	
	With detecting object	OFF		OFF		OFF	
Response frequency**	100 Hz						
Connecting method	Dedicated connector (no soldering possible), EE-1002, EE-1003 (with/1-m cable attached)						
Light source	GaAs infrared LED (pulse modulated) with a peak wavelength of 940 nm						
Receiver	Si photo-diode with (pulse modulated) a sensing wavelength of 850 nm max.						

*The indicator is a GaP red LED (peak emission wavelength: 690 nm).

**The response frequency was measured by detecting the following disks rotating:

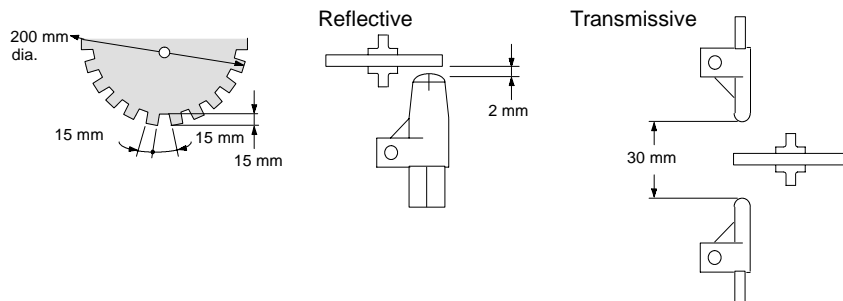

■ CHARACTERISTICS

Ambient illumination	Incandescent/fluorescent light: 3,000 lx max.	
Ambient temperature	Operating	-10°C to 55°C (14°F to 131°F)
	Storage	-25°C to 65°C (-13°F to 149°F)
Ambient humidity	Operating	35% to 85%
	Storage	35% to 95%
Vibration resistance	Destruction: 10 to 55 Hz, 1.5-mm double amplitude for 2 hrs each in X, Y, and Z directions	
Shock resistance	Destruction: 500 m/s ² (approx. 50G's) for 3 times each in X, Y, and Z directions	
Cable length	5 m max. (AWG24 min.)	

Engineering Data

RECEIVER OUTPUT VS. SENSING DISTANCE (TYPICAL)

EE-SPZ301W-01, EE-SPZ401W-01

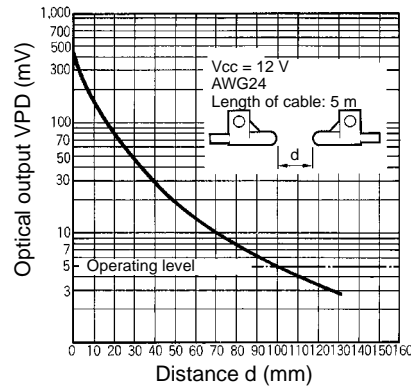

EE-SPZ301W-02, EE-SPZ401W-02

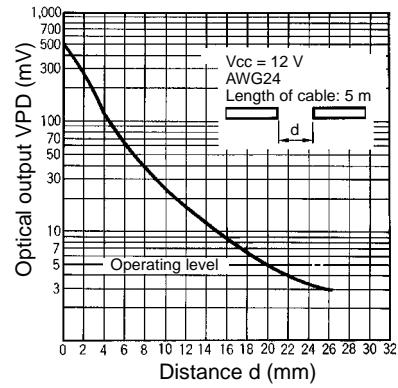

EE-SPZ301Y-01, EE-SPZ401Y-01

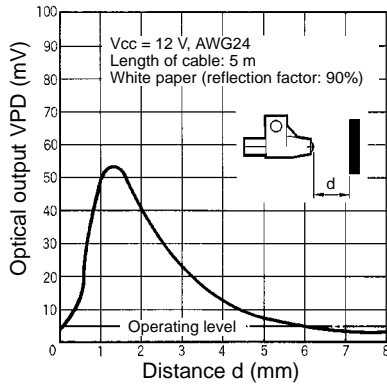

SENSING ANGLE VS. SENSING DISTANCE (TYPICAL)

EE-SPZ301Y-01, EE-SPZ401Y-01

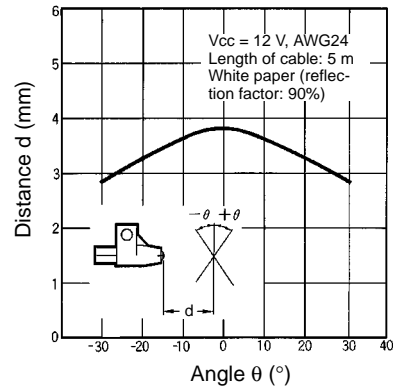

RECEIVER OUTPUT VS. BENDING RADIUS OF FIBER (TYPICAL)

EE-SPZ301Y-01, EE-SPZ401Y-01

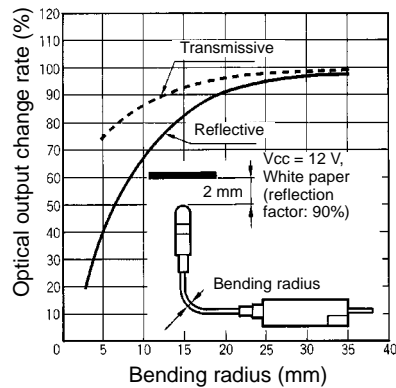

SENSING DISTANCE VS. OBJECT AREA (TYPICAL)

EE-SPZ301Y-01, EE-SPZ401Y-01

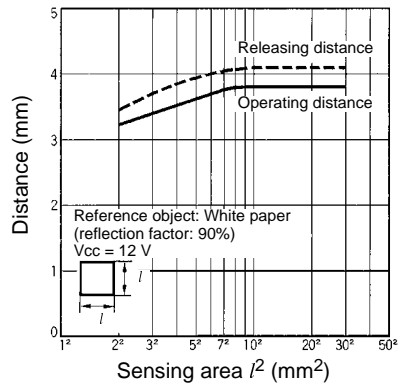

■ OPERATING RANGE (TYPICAL)

EE-SPZ301Y-01, EE-SPZ401Y-01

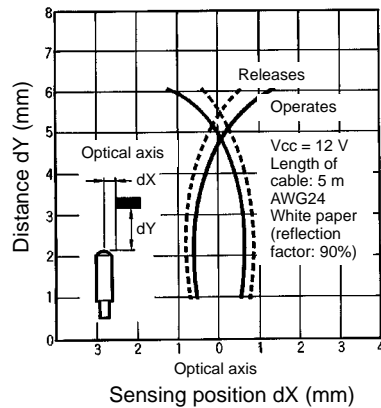

EE-SPZ301Y-01, EE-SPZ401Y-01

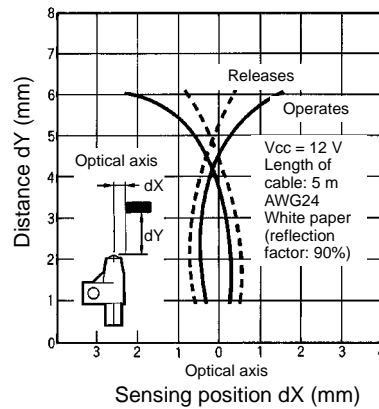

Operation

■ INTERNAL/EXTERNAL CIRCUIT DIAGRAM

Light-ON/Dark-ON

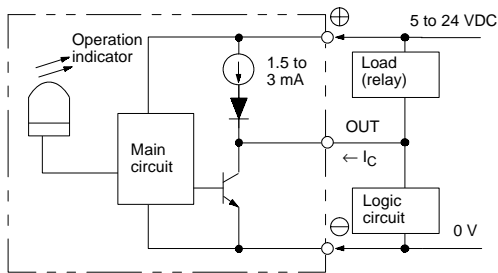

■ TIMING CHART

Light-ON

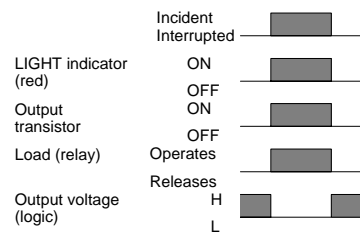

Dark-ON

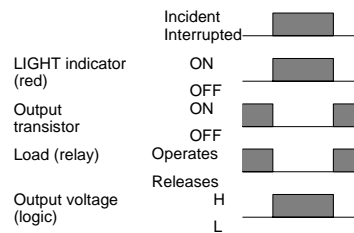

Dimensions

Unit: mm (inch)

■ EE-SPZ301W-01, EE-SPZ401W-01

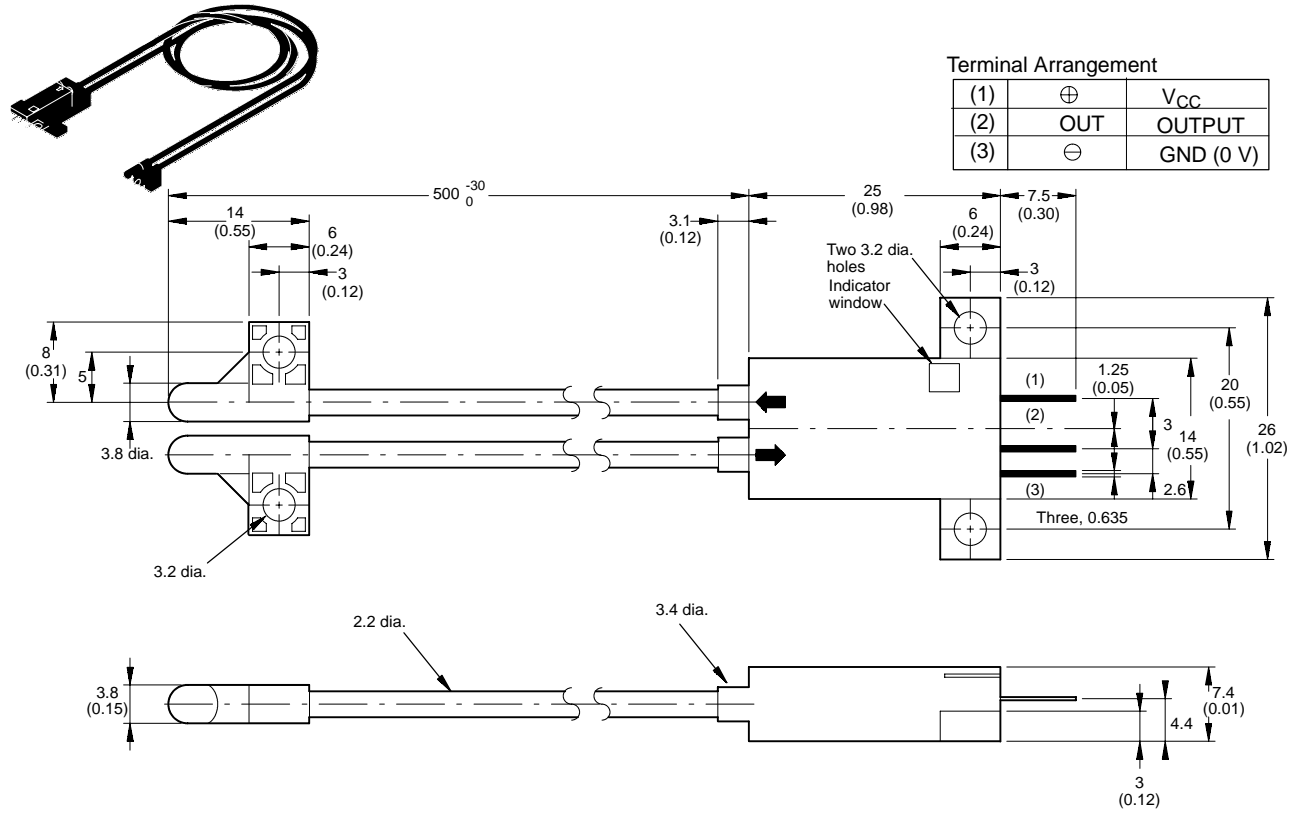

■ EE-SPZ301W-02, EE-SPZ401W-02

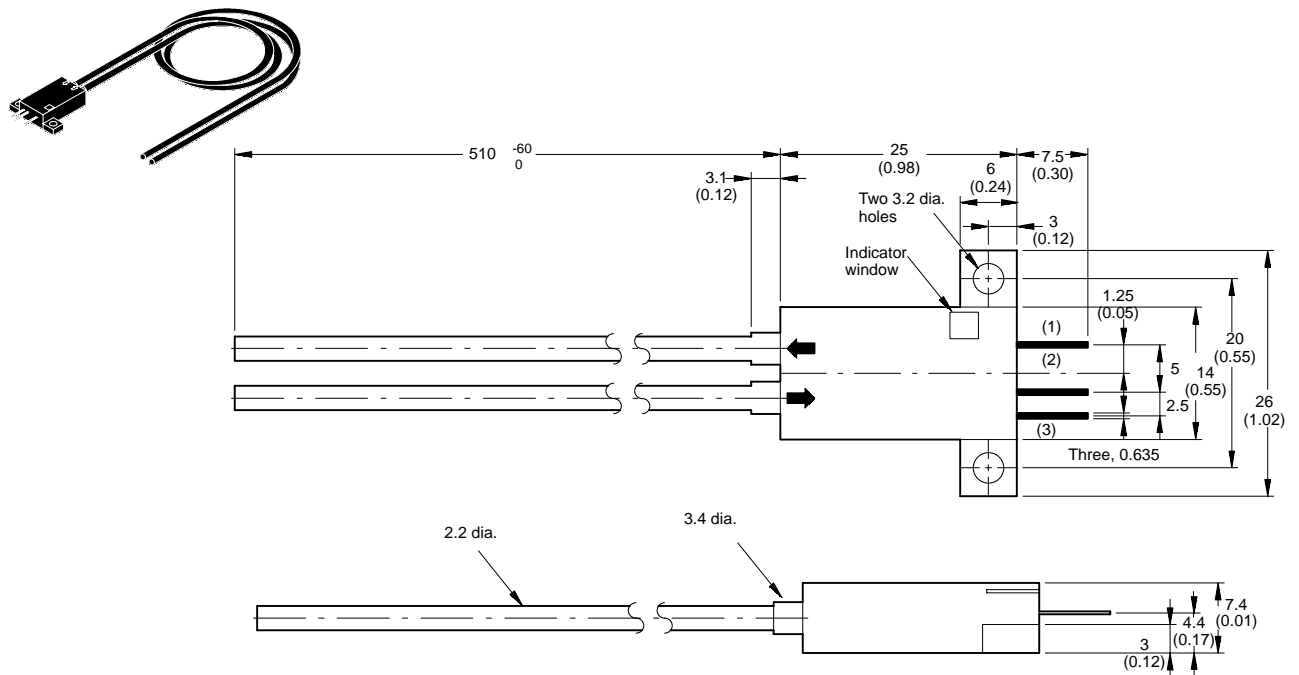

■ EE-SPZ301Y-01, EE-SPZ401Y-01

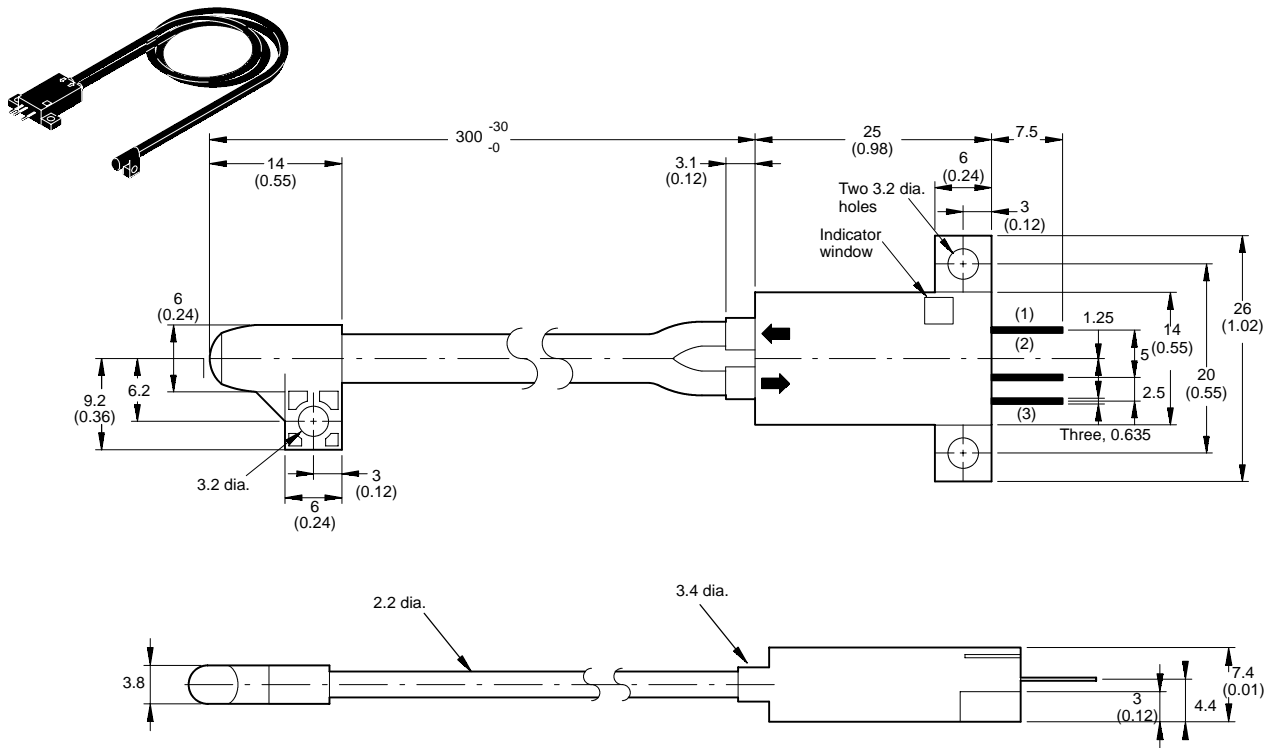

■ EE-1002 CONNECTOR

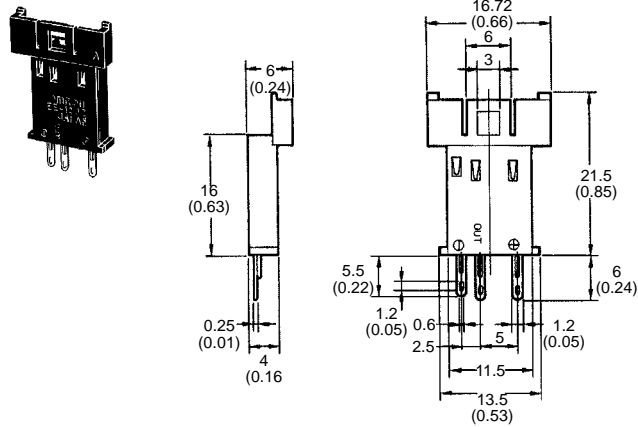

■ EE-SPZ□ + EE-1002

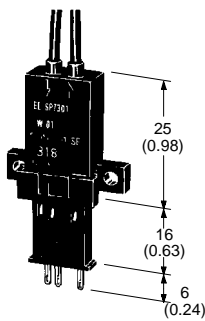

■ EE-1003 CONNECTOR

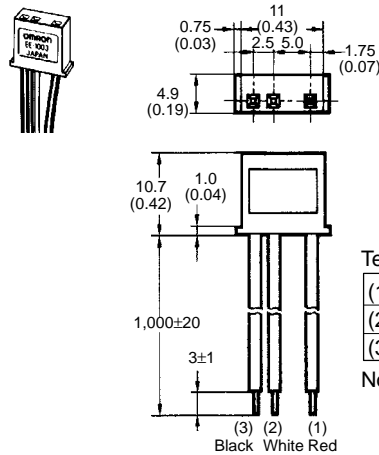

Terminal Arrangement

(1)	Brown (Red)	V _{CC}
(2)	Black (White)	OUTPUT
(3)	Blue (Black)	GND (O V)

Note: Older standard colors are shown in parentheses. The connector comes with a 1-m attached cable.

■ EE-1003A CONNECTOR HOLDER

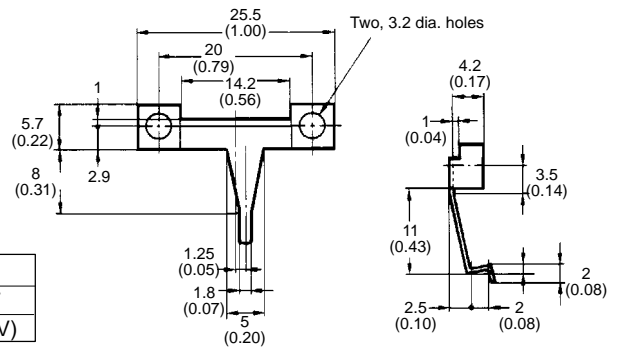

Precautions

Refer to the Technical Information Section for general precautions.

A fiber that has once been connected cannot be disconnected for re-use.

A cable with a thickness of AWG24 min. and a length of 5 m max. must be connected to the output terminals.

To use a cable longer than 5 m, attach a capacitor with a capacitance of approximately 10 μF to the wires as shown below (the distance between the terminal and the capacitor must be within 5 m):

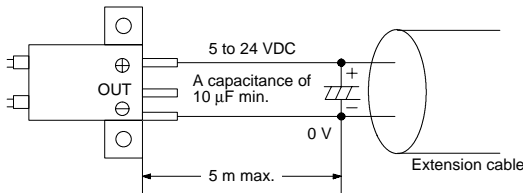

Due to optical problems, the sensing distance of the EE-SPZ must be a minimum of 1 mm, or malfunction will result.

Do not solder the cable to the connectors. Use the EE-1002 Connector or EE-1003 Connector (with a 1-m cable attached) to connect the cable to the output terminals.

Use the EE-1003A Connector Holder to prevent accidental disconnection of the EE-1003 Connector from the EE-SPZ Photomicrosensor.

Do not impose excessive force on the terminals (refer to the diagram below). Excess force will damage the terminals.

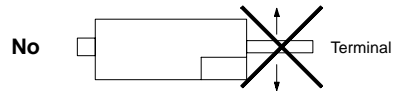

If the metal mounting base is subjected to inductive electrical noise, the photomicrosensor can be activated accidentally. If noise is a problem, take the following precautions:

1. Connect the negative terminal to the mounting base to ensure that there will be no difference in electric potential between the photomicrosensor and mounting base.
2. Connect the negative terminal to the mounting base via a 0.47-μF capacitor.
3. Insert a plastic insulating plate with a thickness of approximately 10 mm between the photomicrosensor and mounting base.

Wire, as shown by the following illustration, to connect a small inductive load (a relay for example) to the photomicrosensor. A diode must be connected parallel to the relay to absorb the reverse voltage.

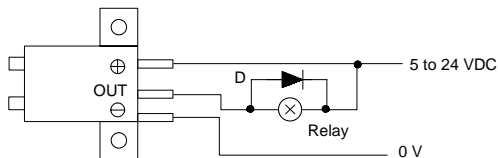

The maximum detectable distance of the EE-SPZ was determined by detecting a piece of white paper with a reflection factor of 90%. The maximum detectable distance of each product varies from one another by 4 to 10 mm. The background object must not be glossy.

■ POWER SUPPLY

When using a standard switching regulator, ground the FG and G terminal to ensure that the photomicrosensor will be in a stable operating condition.

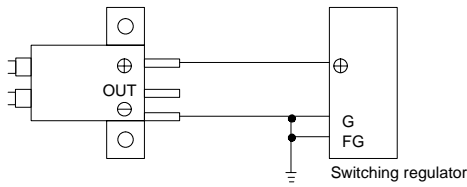

The connection force of the fiber and the Photomicrosensor will decrease when the ambient temperature is high. If high ambient temperatures can be expected, install the fiber with a holder or clip to ensure that the fiber will not pull off.

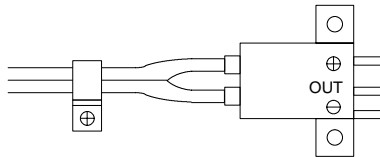

The optical fiber is jacketed with a protective polyethylene coat which should not be exposed to acetone, toluene, benzene, thinner, gasoline, or methyl alcohol.

NOTE: DIMENSIONS SHOWN ARE IN MILLIMETERS. To convert millimeters to inches divide by 25.4.

OMRON[®]
OMRON ELECTRONICS, INC.
 One East Commerce Drive
 Schaumburg, IL 60173
1-800-55-OMRON

OMRON CANADA, INC.
 885 Milner Avenue
 Scarborough, Ontario M1B 5V8
416-286-6465