

THIS DRAWING CONTAINS INFORMATION PROPRIETARY TO RF INDUSTRIES,
 ANY UNAUTHORIZED USE OF THIS DRAWING IS EXPRESSLY PROHIBITED
 WITHOUT WRITTEN PERMISSION FROM RF INDUSTRIES.
 ANY VIOLATION IS PUNISHABLE UNDER U.S. COPYRIGHT LAWS.

ALL DIMENSIONS ARE REFERENCE ONLY

PART NO.

RP-1212-C

REV	DESCRIPTION	DWN	DATE	APPROVED
-	ENGINEERING RELEASE	CZS	12/6/01	JDMc
A	MODIFIED FREQUENCY RANGE	JDM	8/5/10	JDMc

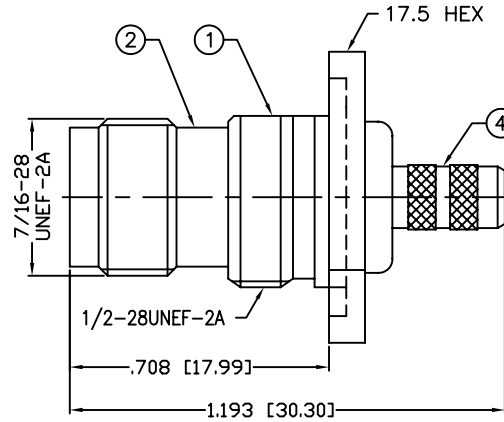
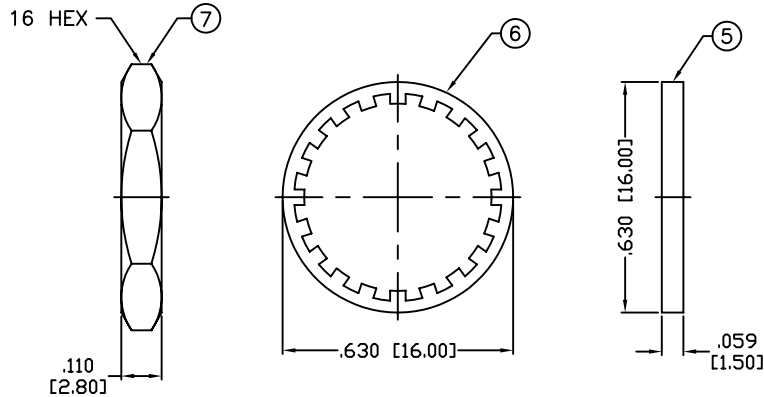

MAX. PANEL THICKNESS = 3.5mm

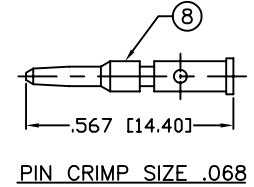

PIN CRIMP SIZE .068

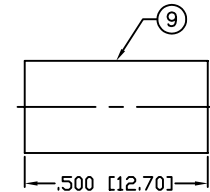

FERRULE CRIMP SIZE .213

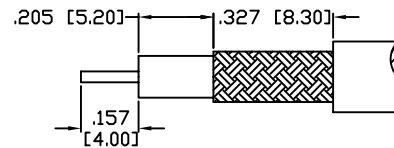

RECOMMENDED STRIPPING DIM'S

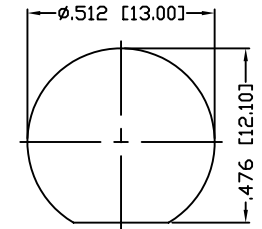

RECOMMENDED MOUNTING HOLE

SPECIFICATIONS:

IMPEDANCE: 50 OHMS
 FREQUENCY RANGE: 0-7 GHz
 VSWR: 1.3 Max.
 WORKING VOLTAGE: 500 V rms
 INSULATION RESISTANCE: 5000 Megohms Minimum
 TEMPERATURE RANGE: -65°C TO +165°C
 FOR RG-58, 58A, 58C, 141, 141A, BELDEN 8240,
 8259, 8262, 9201, 9203, 9310, 9311 & COMM/SCOPE 0268

1	BODY	1	BRASS	NICKEL, 100μ"	008974	DRAWN JDMc 8/5/10
2	PRESS BODY	1	BRASS	NICKEL, 100μ"		
3	INSULATOR	1	PTFE	----		
4	FERRULE STUD	1	BRASS	NICKEL, 100μ"		
5	GASKET	1	RUBBER	----		
6	LOCK WASHER	1	BRASS	NICKEL, 100μ"		
7	HEX NUT	1	BRASS	NICKEL, 100μ"		
8	PIN	1	BRASS	GOLD, 3μ"		
9	FERRULE	1	BRASS	NICKEL, 100μ"		
10					CHECKED	
11						
12						
13					ORJ DRAWN C. ZUNIGA	7/3/01
14						
#	DESCRIPTION	QTY	MATERIAL	FINISH	APPROVALS	DATE

UNLESS OTHERWISE SPECIFIED:
 1. REMOVE ALL BURRS
 2. BREAK ALL CORNERS & EDGES .005 R. MAX.
 3. CHAMFER 1ST & LAST THREADS 45°
 4. SURFACE ROUGHNESS 63 FINISH MIL-STD-10
 5. DIAMETERS ON COMMON CENTERS TO BE CONCENTRIC WITHIN .002 T.I.R.
 6. ALL DIMENSIONS ARE AFTER PLATING.

DIMENSIONS ARE IN INCHES AND [MILLIMETERS]
 UNLESS OTHERWISE NOTED TOLERANCES ARE:
 DECIMALS DIAMETER
 .xxx±.003 [.08] .xxx±.001 [.03]
 .xx±.005 [.13] .xx±.003 [.08]

RFconnectors
 DIVISION OF RF INDUSTRIES, LTD.

7610 MIRAMAR RD
 SAN DIEGO, CA 92126
 (858) 549-6340
 (858) 549-6345 FAX

TNC JACK, CRIMP

REVERSE POLARITY, REAR MOUNT BULKHEAD

SIZE	CABLE GROUP	DWG NO.	REV
A	C	RP-1212-C	A
SCALE:	NTS	CAD FILE	OUTLINE
SHEET			1 OF 1