

Description

The AP2205 series is a positive voltage regulator IC fabricated by a high voltage EPNP process.

The AP2205 has various features such as a wide input voltage range, high accuracy, high ripple rejection, low dropout voltage, low noise, current limit, and ultra-low quiescent current—which make it ideal for use in various USB and portable devices.

The IC consists of a voltage reference, an error amplifier, a resistor network for setting output voltage, a current limit circuit for current protection, a chip enable circuit, a low power shutdown mode for extended battery life, over-current protection, over-temperature protection, as well as reverse current protection.

The AP2205 has 1.5V, 1.8V, 2.5V, 2.8V, 3.0V, 3.3V, 5.0V fixed voltage versions and an adjustable voltage version.

The AP2205 is available in the space-saving SOT25 and SOT89 packages.

Features

- Wide Input Voltage Range: 2.3V to 24V
- Wide Output Voltage Range: 1.24V to 22V
- Excellent Ripple Rejection: 60dB@ f = 1kHz
- Low Dropout Voltage: $V_{DROP} = 100\text{mV}@ I_{OUT} = 100\mu\text{A}$
- Low Ground Current
- High Output Voltage Accuracy
- Compatible with Low ESR Ceramic Capacitor
- Excellent Line/Load Regulation
- Thermal Shutdown Function
- Moisture Sensitivity:
 - SOT89: Level 3 Per J-STD-020
 - SOT25: Level 1 Per J-STD-020
- Terminals: SOT89/ SOT25: Finish—Mate Tin Plated Leads, Solderable per MIL-STD-202, Method 208 ③
- Weight:
 - SOT89: 0.062 grams (Approximate)
 - SOT25: 0.0157 grams (Approximate)
- **For automotive applications requiring specific change control (i.e. parts qualified to AEC-Q100/101/200, PPAP capable, and manufactured in IATF 16949 certified facilities), please [contact us](https://www.diodes.com/quality/product-definitions/) or your local Diodes representative.**
- **Totally Lead-Free & Fully RoHS Compliant (Notes 1 & 2)**
- **Halogen- and Antimony-Free. “Green” Device (Note 3)**

Notes:

1. No purposely added lead. Fully EU Directive 2002/95/EC (RoHS), 2011/65/EU (RoHS 2) & 2015/863/EU (RoHS 3) compliant.
2. See <https://www.diodes.com/quality/lead-free/> for more information about Diodes Incorporated's definitions of Halogen- and Antimony-free, "Green" and Lead-free.
3. Halogen- and Antimony-free "Green" products are defined as those which contain <900ppm bromine, <900ppm chlorine (<1500ppm total Br + Cl) and <1000ppm antimony compounds.

Pin Assignments

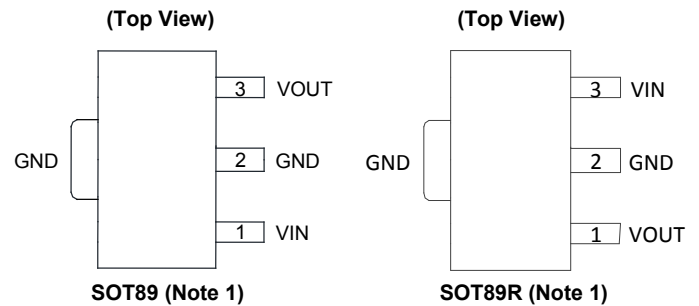

Note: The substrate/exposed pad should be connected to GND or open.

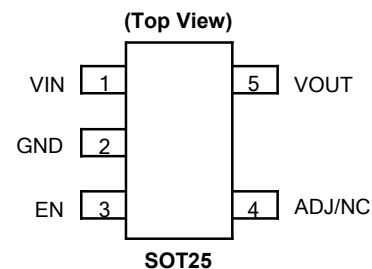

Applications

- Battery-powered Equipment
- Laptop, Palmtops, Notebook Computers
- Portable Information Appliances
- Industrial/Automotive Applications

Typical Applications Circuit

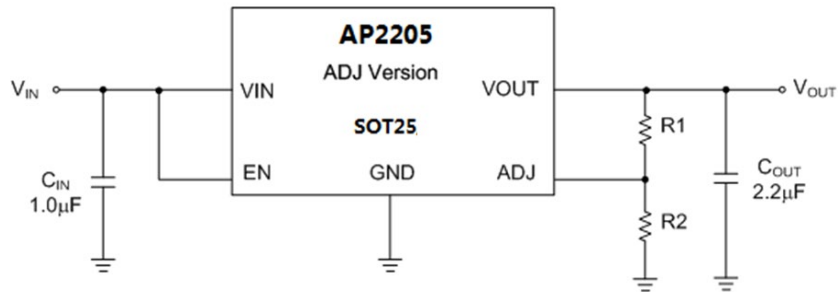
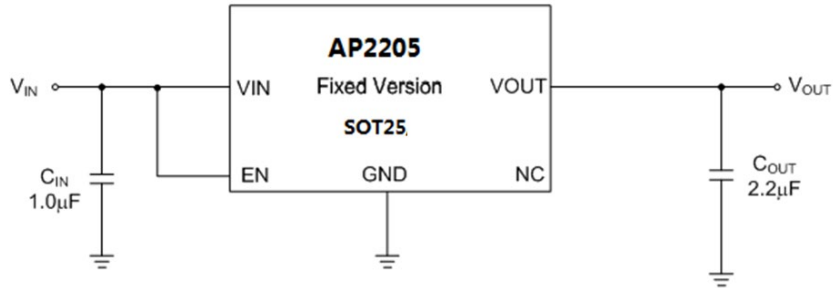
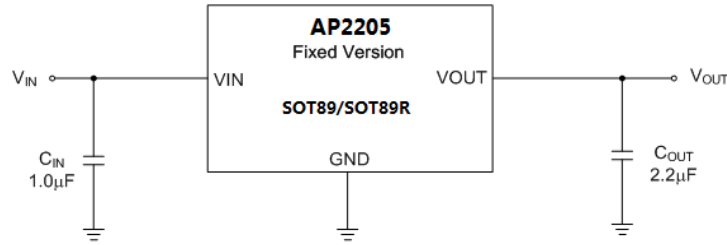

$$V_{OUT} = V_{REF}(1+(R1/R2))$$

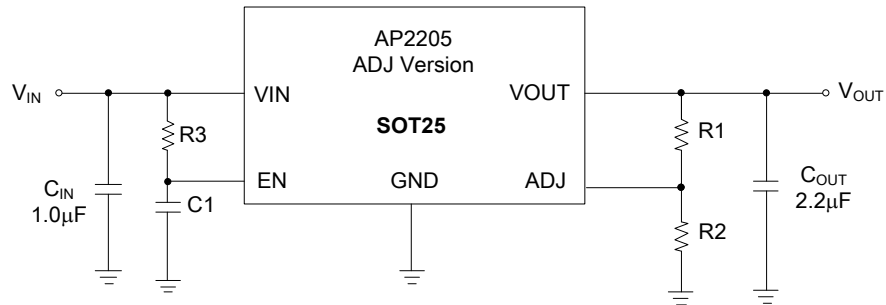

Startup Time Adjustable by External R3C1 Circuit

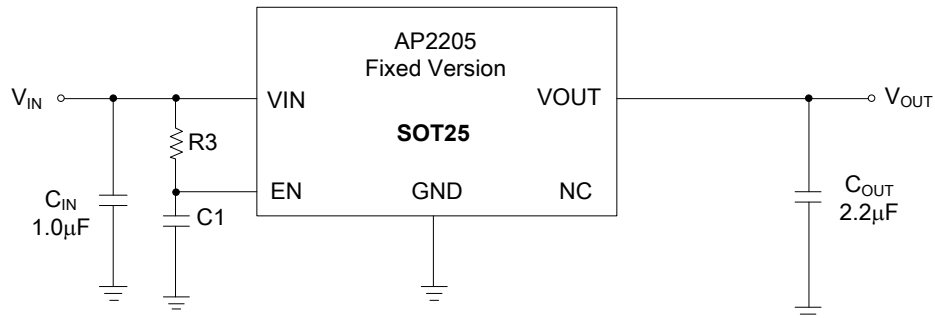

Startup Time Adjustable by External R3C1 Circuit

Pin Descriptions

Pin Number			Pin Name	Function
SOT25	SOT89	SOT89R		
	Y	YR		
1	1	3	VIN	Input voltage
2	2	2	GND	Ground
3	—	—	EN	Enable input
4	—	—	ADJ/NC	Adjust output for ADJ version/Not connected for fixed version
5	3	1	VOUT	Regulated output voltage

Functional Block Diagram

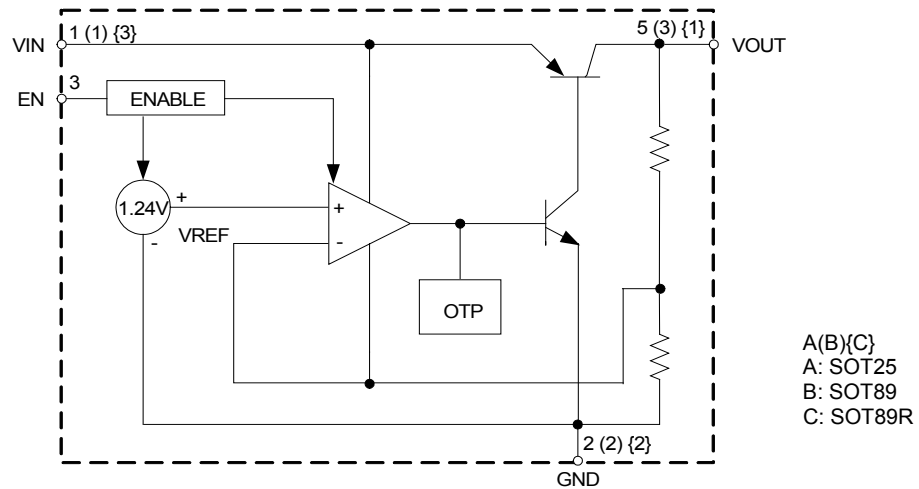

Fixed Version

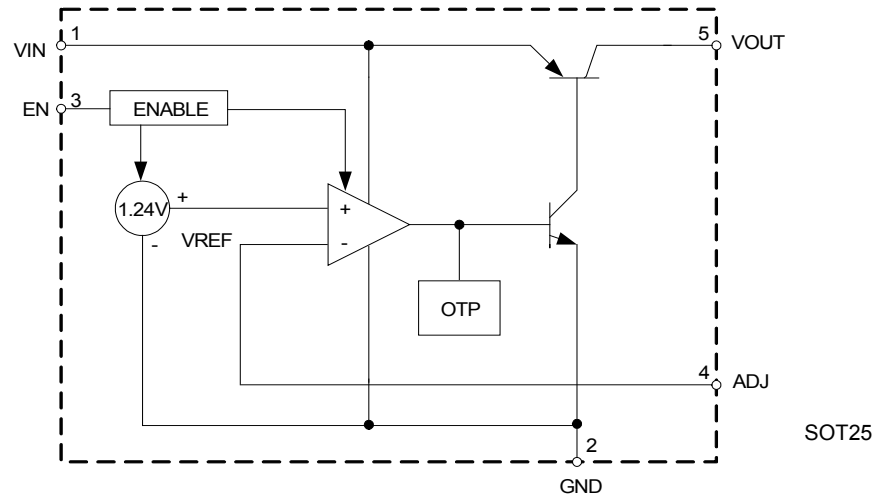

Adjustable Version

Absolute Maximum Ratings (Note 5)

Symbol	Parameter	Rating		Unit
V_{IN}	Supply Input Voltage	36		V
V_{CE}	Enable Input Voltage	36		V
I_{OUT}	Output Current	250		mA
T_{LEAD}	Lead Temperature (Soldering, 10sec)	+260		°C
T_J	Operating Junction Temperature	+150		°C
θ_{JA}	Thermal Resistance (Note 6)	SOT25	160	°C/W
		SOT89/SOT89R	129	
θ_{JC}	Thermal Resistance	SOT25	29	°C/W
		SOT89/SOT89R	26	
T_{STG}	Storage Temperature Range	-65 to +150		°C
—	ESD (Charge Device Model)	1000		V
—	ESD (Human Body Model)	2000		V

- Notes:
- Stresses greater than those listed under "Absolute Maximum Ratings" may cause permanent damage to the device. These are stress ratings only, and functional operation of the device at these or any other conditions beyond those indicated under "Recommended Operating Conditions" is not implied. Exposure to "Absolute Maximum Ratings" for extended periods may affect device reliability.
 - θ_{JA} is measured with the component mounted on a 2-Layer FR-4 PCB board with 1.5cm*1.5cm thermal sink pad in free air.

Recommended Operating Conditions

Symbol	Parameter	Min	Max	Unit
V_{IN}	Supply Input Voltage	2.3	24	V
T_J	Operating Junction Temperature	-40	+125	°C
I_{OUT}	Output Current	$V_{OUT} \leq 1.8V$	150	mA
		$V_{OUT} > 1.8V$	200	

Electrical Characteristics (@ $V_{IN} = V_{OUT} + 1V$, $T_J = +25^\circ C$, $I_{OUT} = 100\mu A$, $C_{IN} = 1.0\mu F$, $C_{OUT} = 2.2\mu F$, **Bold** typeface applies over $-40^\circ C \leq T_J \leq +125^\circ C$, unless otherwise specified.)

Symbol	Parameter	Conditions	Min	Typ	Max	Unit	
V_{OUT}	Output Voltage	Variation from Specified V_{OUT}	$V_{OUT} \times 98\%$	—	$V_{OUT} \times 102\%$	V	
V_{REF}	Reference Voltage	—	1.215	1.24	1.265	V	
V_{IN}	Input Voltage	—	2.3	—	24	V	
$I_{OUT(Max)}$	Maximum Output Current	$V_{IN} - V_{OUT} = 1V$, $V_{OUT} = 98\% \times V_{OUT}$	200	250	—	mA	
$\Delta V_{OUT}/\Delta V_{IN}$	Line Regulation	$V_{OUT} + 1V \leq V_{IN} \leq 24V$	—	0.05	—	%	
$\Delta V_{OUT}/V_{OUT}$	Load Regulation	$1mA \leq I_{OUT} \leq 200mA$	—	0.5	—	%	
V_{DROP}	Dropout Voltage (Note 7)	$I_{OUT} = 100\mu A$	—	100	150	mV	
		$I_{OUT} = 50mA$	—	270	350		
		$I_{OUT} = 100mA$	—	320	460		
		$I_{OUT} = 150mA$	—	360	500		
I_{GND}	Ground Current	$I_{OUT} = 100\mu A$	—	36	—	μA	
		$I_{OUT} = 50mA$	—	0.5	—	mA	
		$I_{OUT} = 100mA$	—	1.3	—		
		$I_{OUT} = 150mA$	—	2.5	—		
I_{STD}	Standby Current	$V_{IN} = V_{OUT} + 1V$ V_{EN} in OFF Mode	—	0.01	1.0	μA	
PSRR	Power Supply Rejection Ration	Ripple 0.5V _{P-P} $V_{IN} = V_{OUT} + 1V$	f = 100Hz	—	60	—	dB
			f = 1kHz	—	60	—	
$\Delta V_{OUT}/(V_{OUT} \times \Delta T)$	Output Voltage Temperature Coefficient	$I_{OUT} = 100\mu A$, $-40^\circ C \leq T_J \leq +125^\circ C$	—	± 100	—	ppm/ $^\circ C$	
V_{NOI}	RMS Output Noise	$T_J = +25^\circ C$, $10Hz \leq f \leq 100kHz$	—	30	—	μV_{rms}	
I_{ADJ}	ADJ Pin Current	$I_{OUT} = 100\mu A$	—	0.5	—	μA	
I_{EN}	EN Pin Current	$V_{EN} = V_{OUT} + 1V$	—	3	—	μA	
—	EN "High" Voltage	EN Input Voltage "High"	2.0	—	—	V	
—	EN "Low" Voltage	EN Input Voltage "Low"	—	—	0.4	V	

Notes: 7. Dropout voltage is only valid when $V_{OUT} \geq 2.3V$ because of the minimum input voltage limits.

Performance Characteristics

Output Voltage vs. Input Voltage

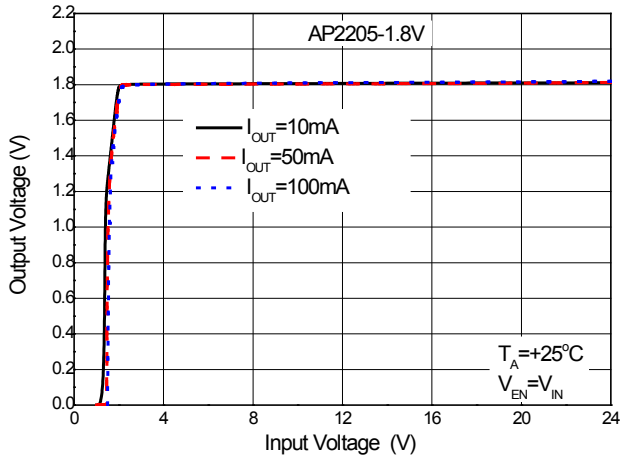

Output Voltage vs. Input Voltage

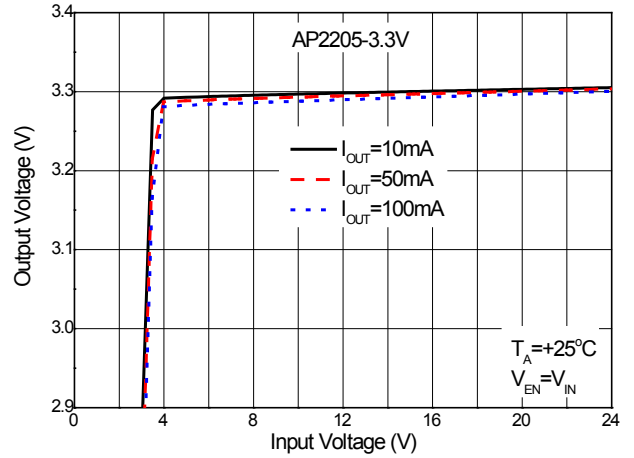

Output Voltage vs. Temperature

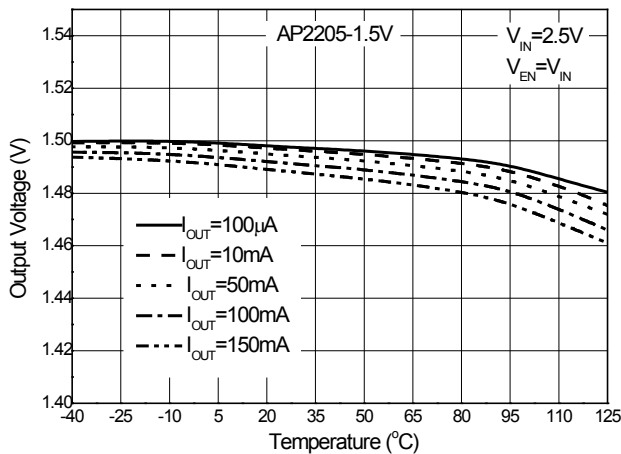

Output Voltage vs. Temperature

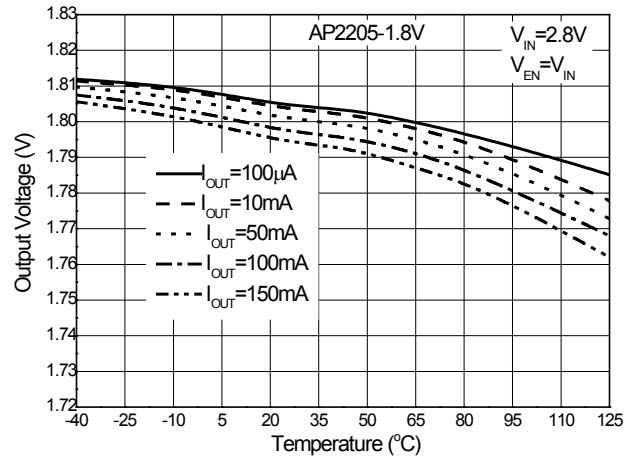

Output Voltage vs. Temperature

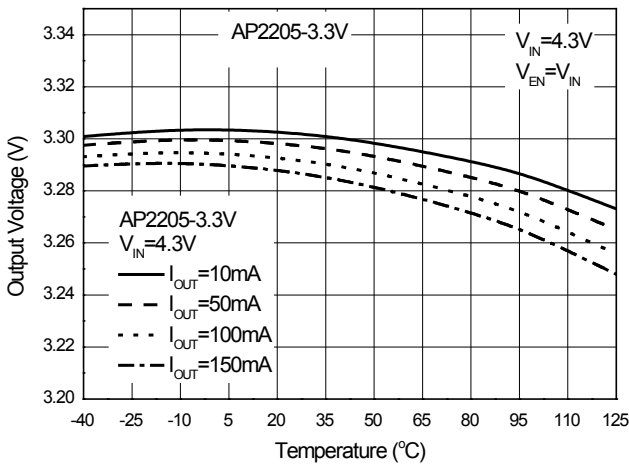

Output Voltage vs. Temperature

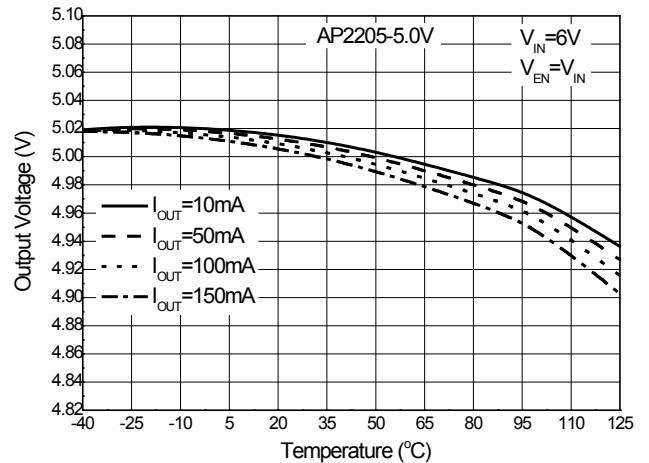

Performance Characteristics (Cont.)

Output Voltage vs. Output Current

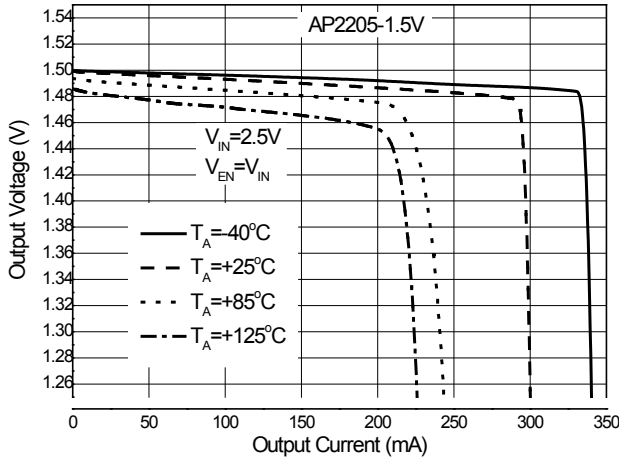

Output Voltage vs. Output Current

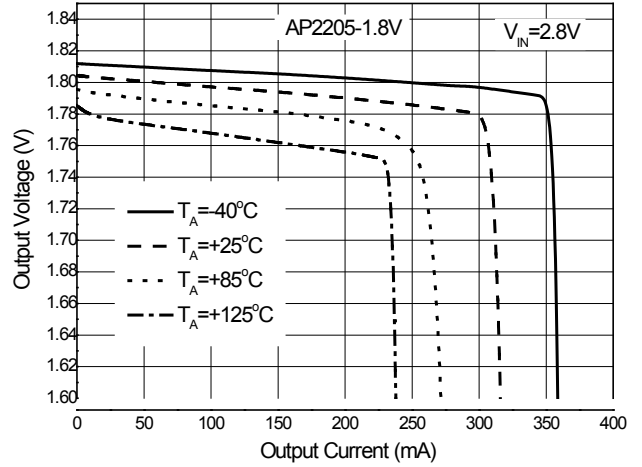

Output Voltage vs. Output Current

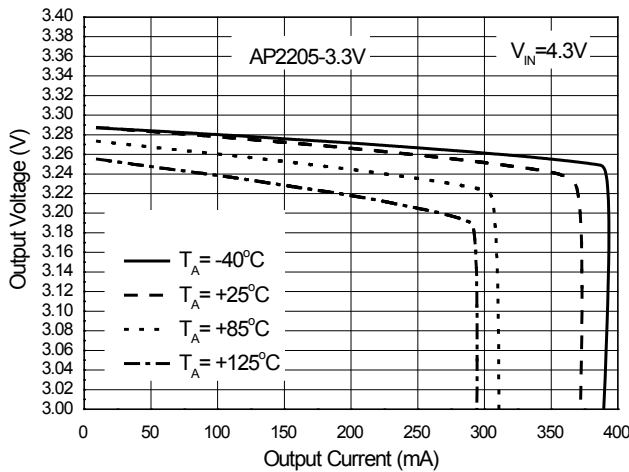

Output Voltage vs. Output Current

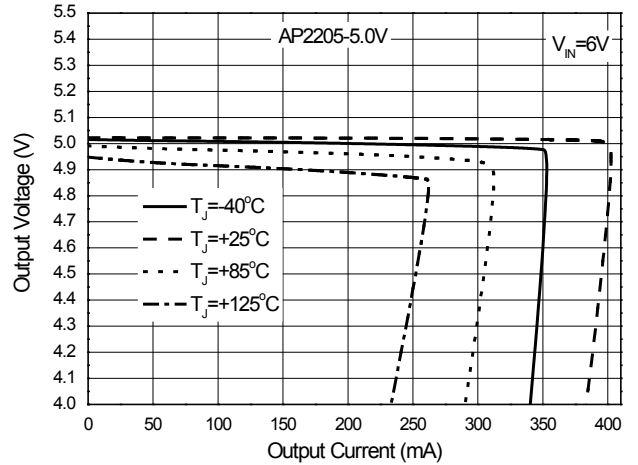

Output Voltage vs. Output Current

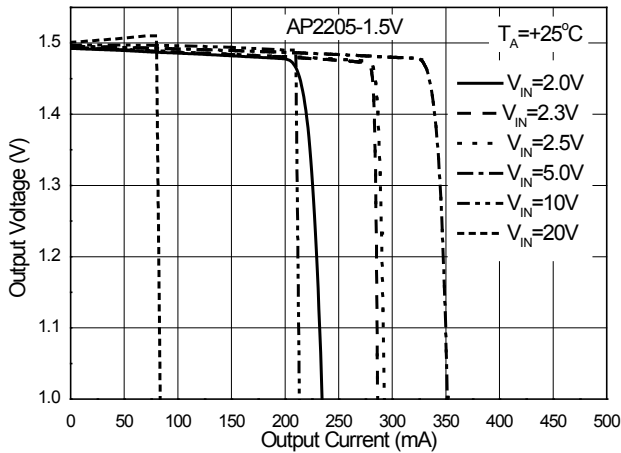

Output Voltage vs. Output Current

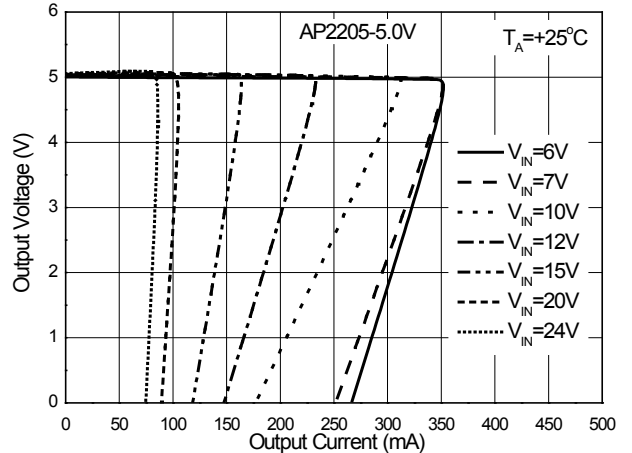

Performance Characteristics (Cont.)

Dropout Voltage vs. Output Current

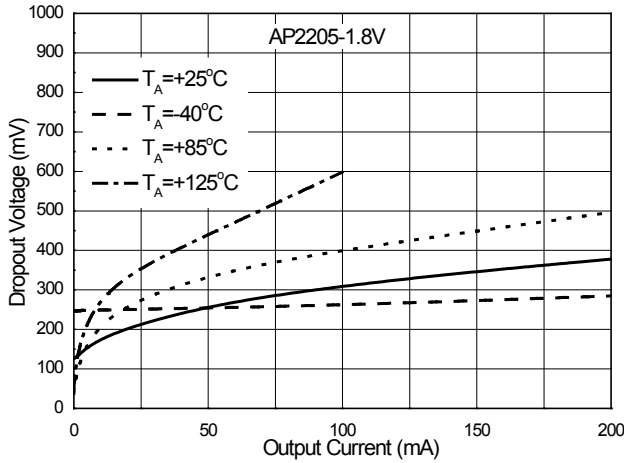

Dropout Voltage vs. Output Current

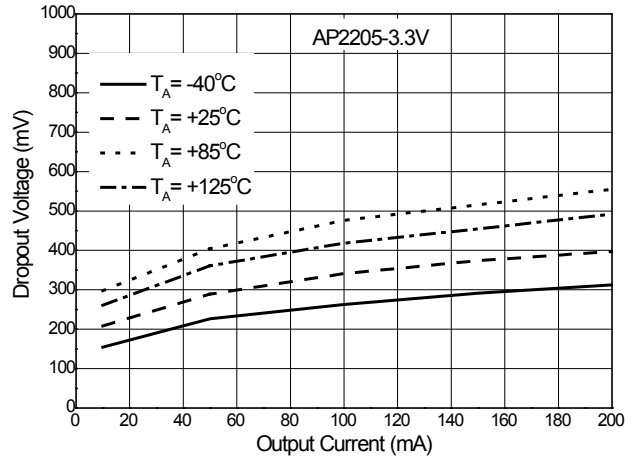

Dropout Voltage vs. Temperature

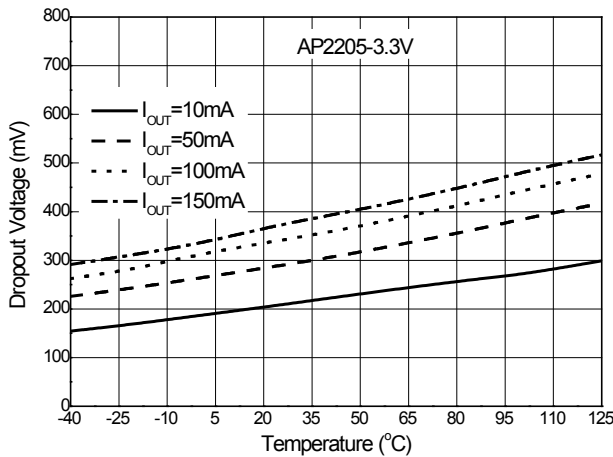

Dropout Voltage vs. Temperature

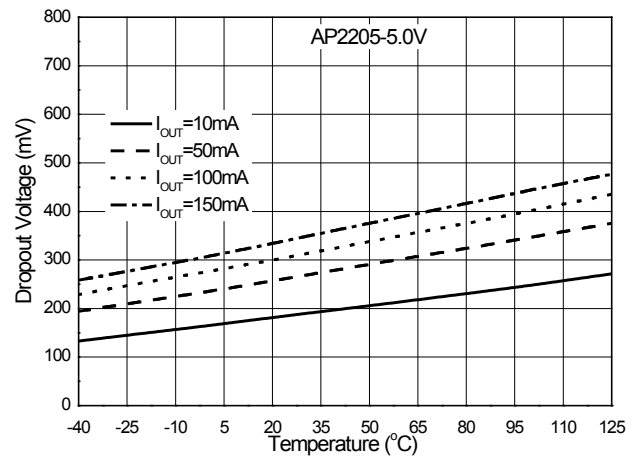

Supply Current vs. Input Voltage

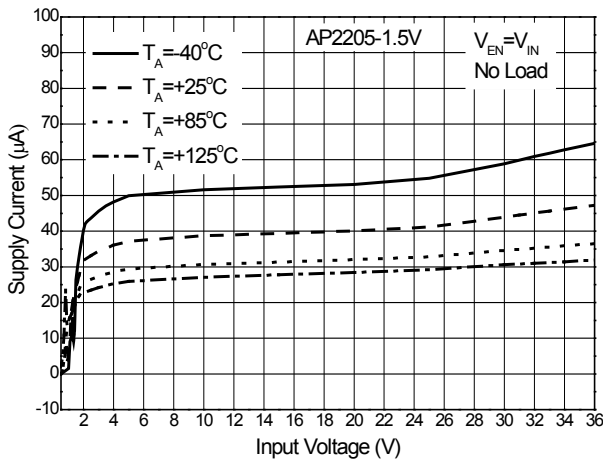

Supply Current vs. Input Voltage

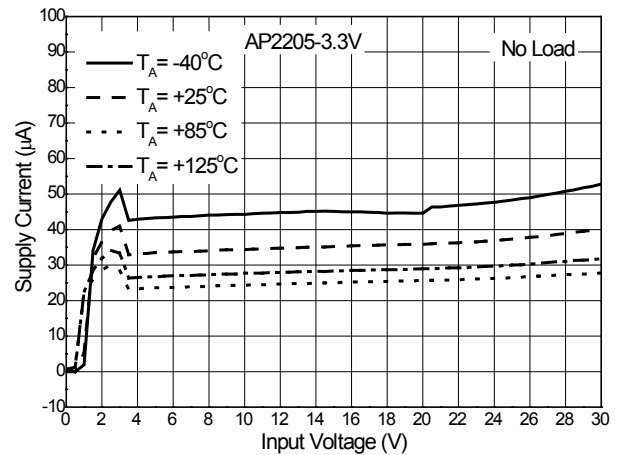

Performance Characteristics (Cont.)

Ground Current vs. Output Current

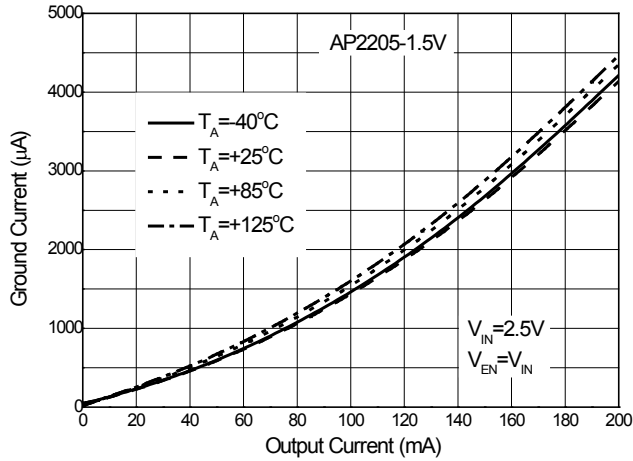

Ground Current vs. Output Current

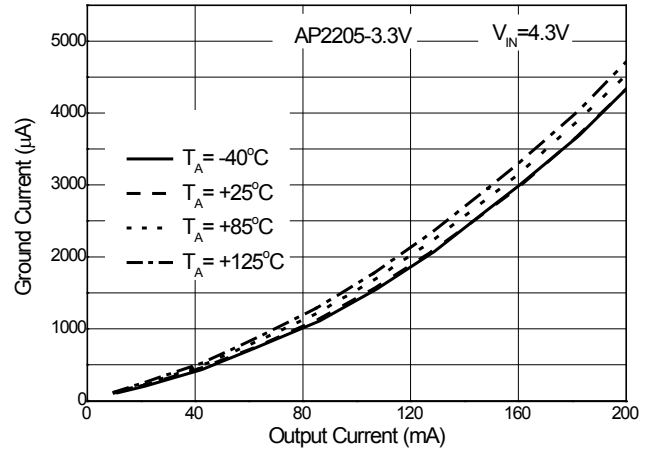

Load Transient
(Conditions: $V_{IN}=2.5V$, $C_{IN}=1.0\mu F$, $C_{OUT}=2.2\mu F$, $I_{OUT}=1mA$ to $50mA$)

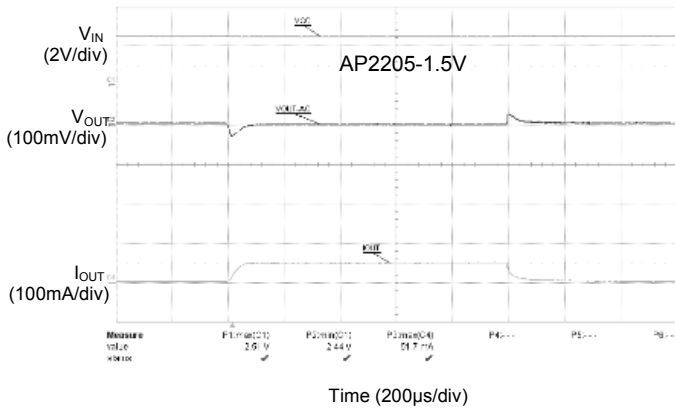

Load Transient
(Conditions: $V_{IN}=2.5V$, $C_{IN}=1.0\mu F$, $C_{OUT}=2.2\mu F$, $I_{OUT}=1mA$ to $100mA$)

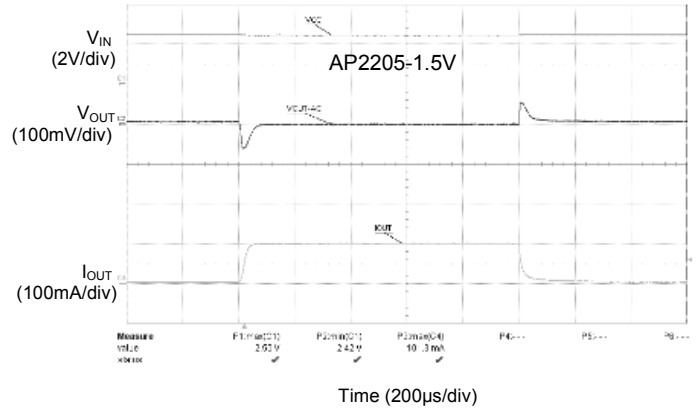

Load Transient
(Conditions: $V_{IN}=2.5V$, $C_{IN}=1.0\mu F$, $C_{OUT}=2.2\mu F$, $I_{OUT}=1mA$ to $150mA$)

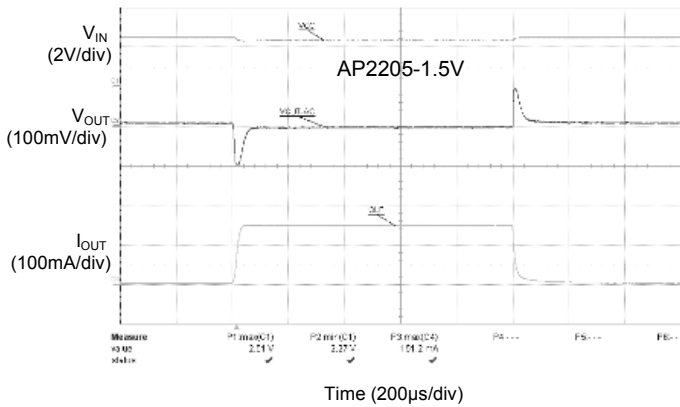

Load Transient
(Conditions: $V_{IN}=2.5V$, $C_{IN}=1.0\mu F$, $C_{OUT}=2.2\mu F$, $I_{OUT}=50mA$ to $100mA$)

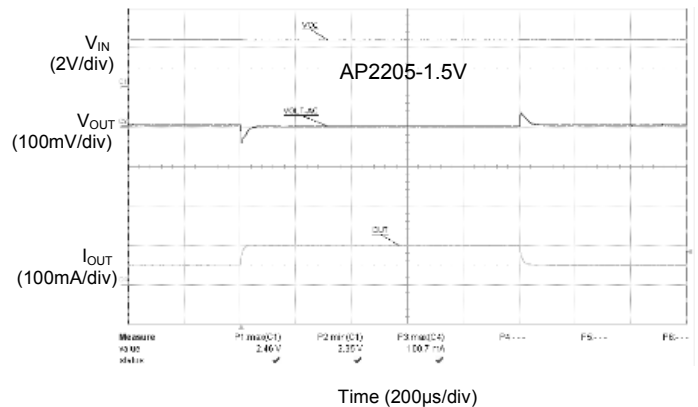

Performance Characteristics (Cont.)

Enable Input Response

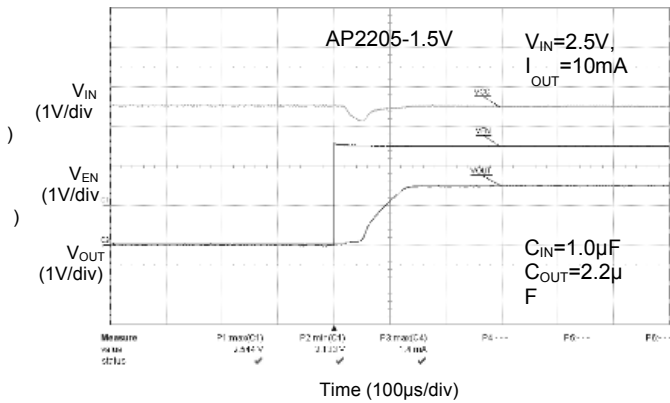

Adjustable Start-up Time by RC

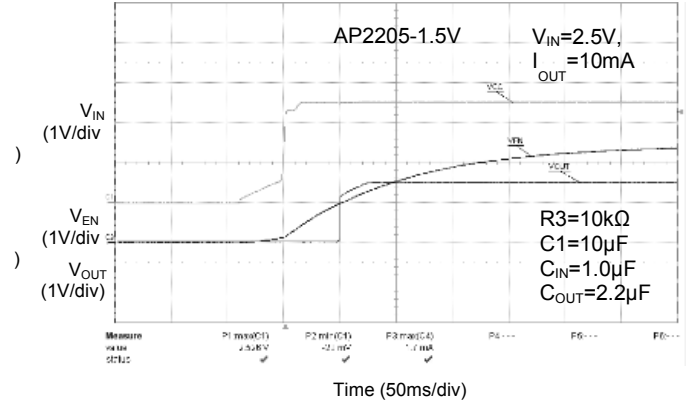

Enable Input Response

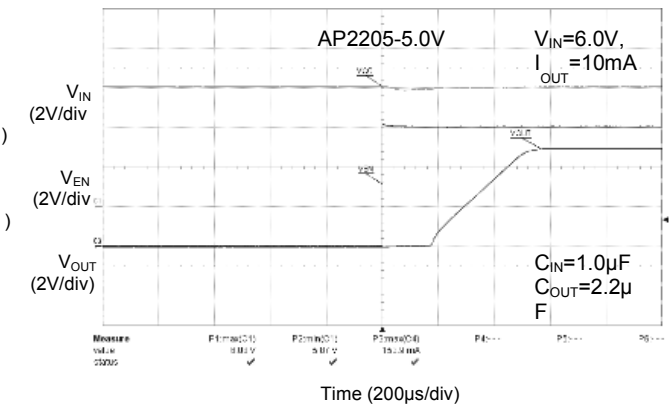

Adjustable Start-up Time by RC

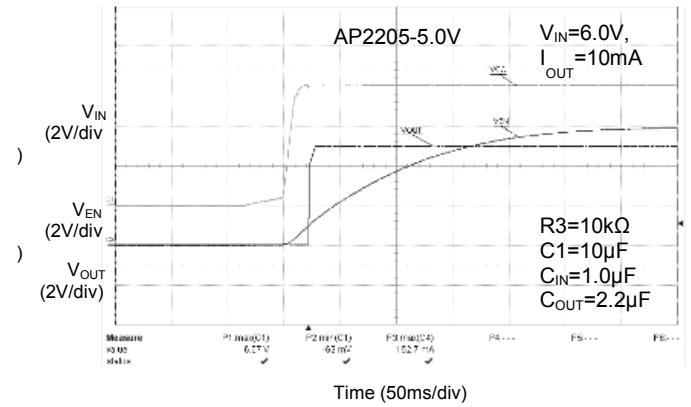

Maximum Output Current vs. Ambient Temperature

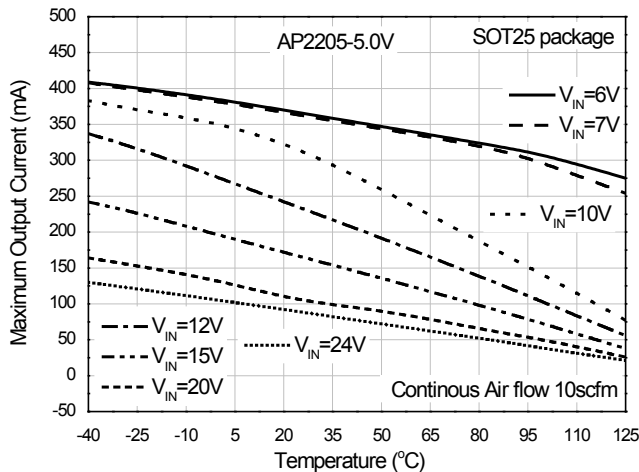

Enable Pin Current vs. Enable Input Voltage

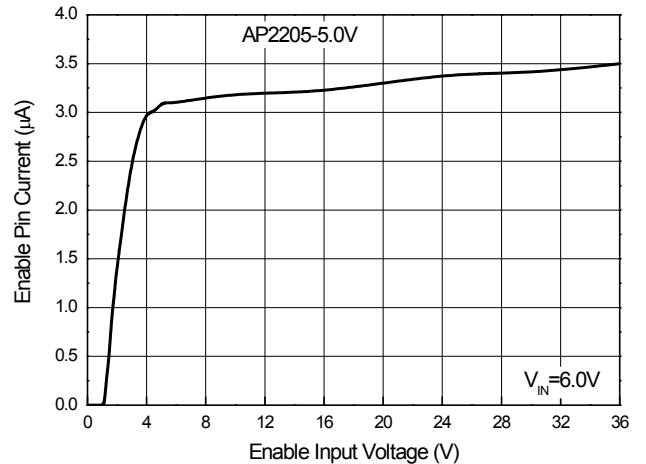

Performance Characteristics (Cont.)

PSRR vs. Frequency

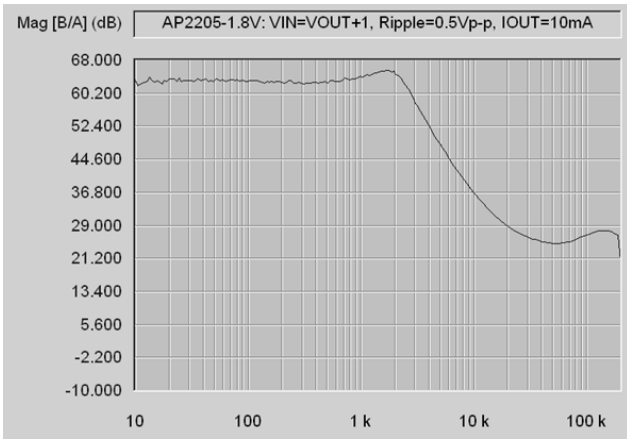

PSRR vs. Frequency

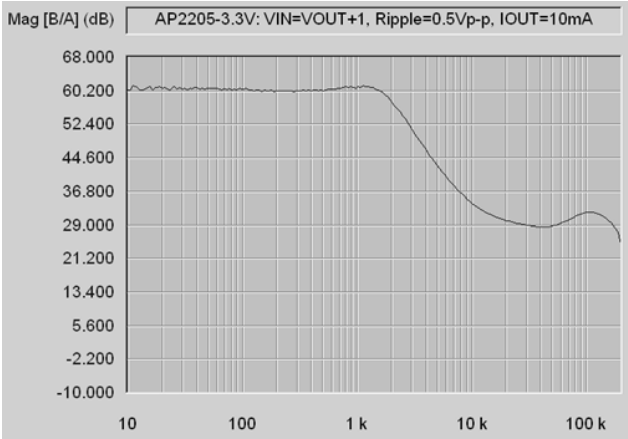

Ordering Information

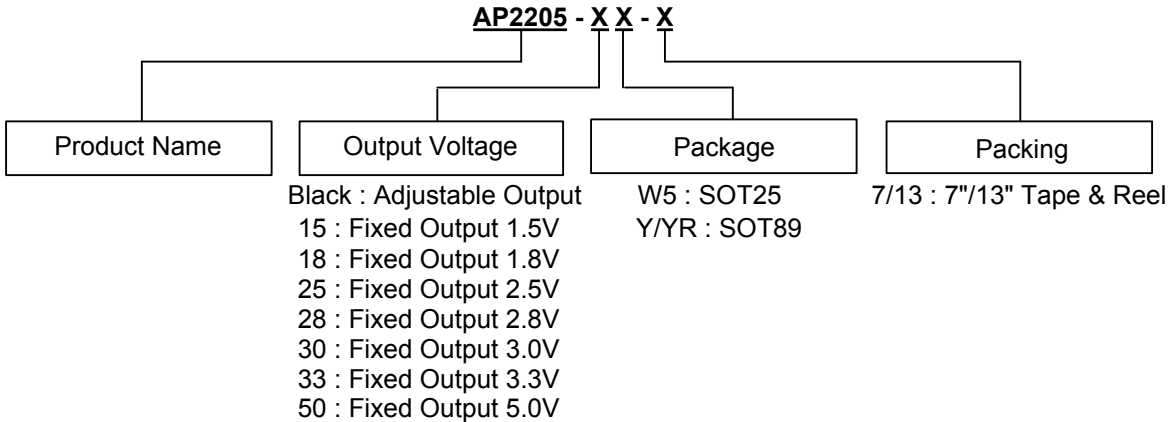

Part Number	Package Code	Package	13"/7" Tape and Reel	
			Quantity	Part Number Suffix
AP2205-XXY-13	Y	SOT89	2,500/Tape & Reel	-13
AP2205-XXYR-13	YR	SOT89	2,500/Tape & Reel	-13
AP2205-W5-7	W5	SOT25	3,000/Tape & Reel	-7
AP2205-XXW5-7	W5	SOT25	3,000/Tape & Reel	-7

Marking Information

(1) SOT25

(Top View)

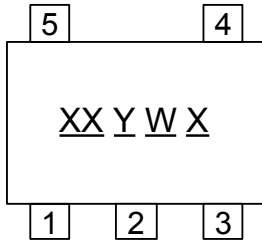

XX : Identification Code
Y : Year 0 to 9
W : Week : A to Z : 1 to 26 week;
 a to z : 27 to 52 week; z represents
 52 and 53 week
X : Internal Code

Part Number	Package	Identification Code
AP2205-W5-7	SOT25	5A
AP2205-15W5-7	SOT25	5B
AP2205-18W5-7	SOT25	5C
AP2205-25W5-7	SOT25	5D
AP2205-28W5-7	SOT25	5E
AP2205-30W5-7	SOT25	5F
AP2205-33W5-7	SOT25	5G
AP2205-50W5-7	SOT25	5H

Marking Information (Cont.)

(2) SOT89

(Top View)

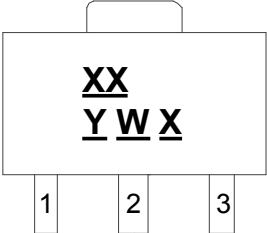

XX : Identification code
Y : Year : 0~9
W : Week : A~Z : 1~26 week;
a~z : 27~52 week;
z represents 52 and 53 week
X : Internal code

Part Number	Package	Identification Code
AP2205-15Y-13	SOT89	5B
AP2205-18Y-13	SOT89	5C
AP2205-25Y-13	SOT89	5D
AP2205-28Y-13	SOT89	5E
AP2205-30Y-13	SOT89	5F
AP2205-33Y-13	SOT89	5G
AP2205-50Y-13	SOT89	5H
AP2205-15YR-13	SOT89	6B
AP2205-18YR-13	SOT89	6C
AP2205-25YR-13	SOT89	6D
AP2205-28YR-13	SOT89	6E
AP2205-30YR-13	SOT89	6F
AP2205-33YR-13	SOT89	6G
AP2205-50YR-13	SOT89	6H

Package Outline Dimensions (All dimensions in mm(inch).)

(1) Package Type: SOT25

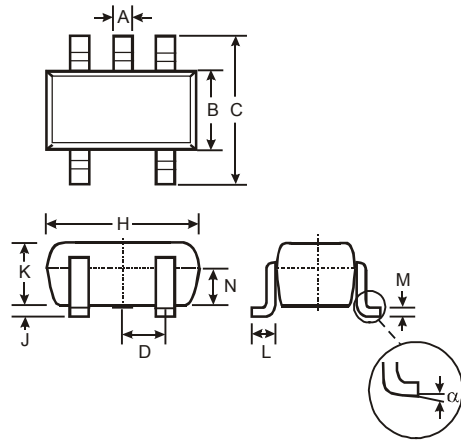

SOT25			
Dim	Min	Max	Typ
A	0.35	0.50	0.38
B	1.50	1.70	1.60
C	2.70	3.00	2.80
D	-	-	0.95
H	2.90	3.10	3.00
J	0.013	0.10	0.05
K	1.00	1.30	1.10
L	0.35	0.55	0.40
M	0.10	0.20	0.15
N	0.70	0.80	0.75
α	0°	8°	-
All Dimensions in mm			

(2) Package Type: SOT89

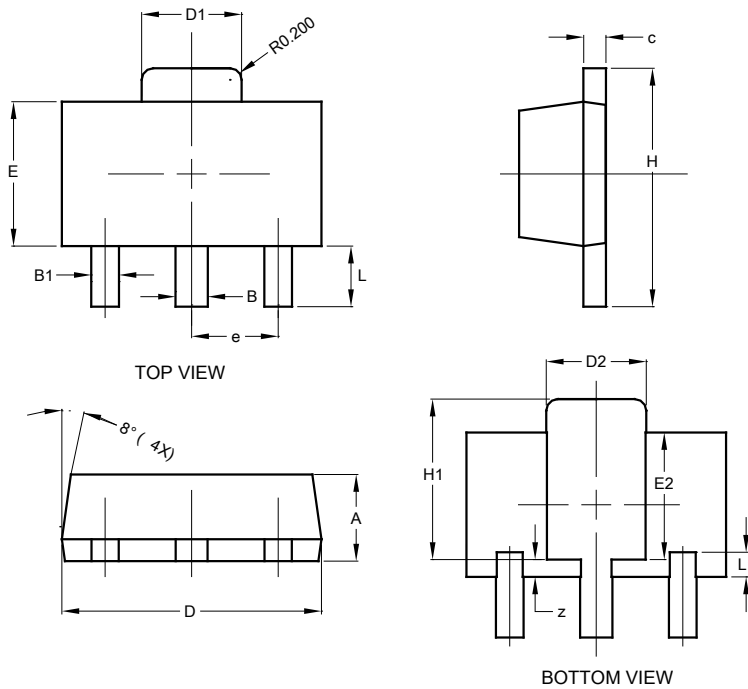

SOT89			
Dim	Min	Max	Typ
A	1.40	1.60	1.50
B	0.50	0.62	0.56
B1	0.42	0.54	0.48
c	0.35	0.43	0.38
D	4.40	4.60	4.50
D1	1.62	1.83	1.733
D2	1.61	1.81	1.71
E	2.40	2.60	2.50
E2	2.05	2.35	2.20
e	-	-	1.50
H	3.95	4.25	4.10
H1	2.63	2.93	2.78
L	0.90	1.20	1.05
L1	0.327	0.527	0.427
z	0.20	0.40	0.30
All Dimensions in mm			

Suggested Pad Layout

(1) Package Type: SOT25

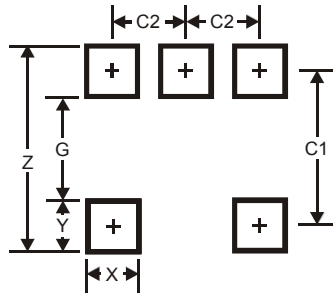

Dimensions	Value
Z	3.20
G	1.60
X	0.55
Y	0.80
C1	2.40
C2	0.95

(2) Package Type: SOT89

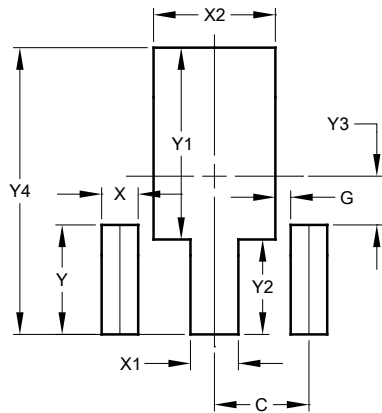

Dimensions	Value (in mm)
C	1.500
G	0.244
X	0.580
X1	0.760
X2	1.933
Y	1.730
Y1	3.030
Y2	1.500
Y3	0.770
Y4	4.530

IMPORTANT NOTICE

DIODES INCORPORATED MAKES NO WARRANTY OF ANY KIND, EXPRESS OR IMPLIED, WITH REGARDS TO THIS DOCUMENT, INCLUDING, BUT NOT LIMITED TO, THE IMPLIED WARRANTIES OF MERCHANTABILITY AND FITNESS FOR A PARTICULAR PURPOSE (AND THEIR EQUIVALENTS UNDER THE LAWS OF ANY JURISDICTION).

Diodes Incorporated and its subsidiaries reserve the right to make modifications, enhancements, improvements, corrections or other changes without further notice to this document and any product described herein. Diodes Incorporated does not assume any liability arising out of the application or use of this document or any product described herein; neither does Diodes Incorporated convey any license under its patent or trademark rights, nor the rights of others. Any Customer or user of this document or products described herein in such applications shall assume all risks of such use and will agree to hold Diodes Incorporated and all the companies whose products are represented on Diodes Incorporated website, harmless against all damages.

Diodes Incorporated does not warrant or accept any liability whatsoever in respect of any products purchased through unauthorized sales channel. Should Customers purchase or use Diodes Incorporated products for any unintended or unauthorized application, Customers shall indemnify and hold Diodes Incorporated and its representatives harmless against all claims, damages, expenses, and attorney fees arising out of, directly or indirectly, any claim of personal injury or death associated with such unintended or unauthorized application.

Products described herein may be covered by one or more United States, international or foreign patents pending. Product names and markings noted herein may also be covered by one or more United States, international or foreign trademarks.

This document is written in English but may be translated into multiple languages for reference. Only the English version of this document is the final and determinative format released by Diodes Incorporated.

LIFE SUPPORT

Diodes Incorporated products are specifically not authorized for use as critical components in life support devices or systems without the express written approval of the Chief Executive Officer of Diodes Incorporated. As used herein:

A. Life support devices or systems are devices or systems which:

1. are intended to implant into the body, or
2. support or sustain life and whose failure to perform when properly used in accordance with instructions for use provided in the labeling can be reasonably expected to result in significant injury to the user.

B. A critical component is any component in a life support device or system whose failure to perform can be reasonably expected to cause the failure of the life support device or to affect its safety or effectiveness.

Customers represent that they have all necessary expertise in the safety and regulatory ramifications of their life support devices or systems, and acknowledge and agree that they are solely responsible for all legal, regulatory and safety-related requirements concerning their products and any use of Diodes Incorporated products in such safety-critical, life support devices or systems, notwithstanding any devices- or systems-related information or support that may be provided by Diodes Incorporated. Further, Customers must fully indemnify Diodes Incorporated and its representatives against any damages arising out of the use of Diodes Incorporated products in such safety-critical, life support devices or systems.

Copyright © 2020, Diodes Incorporated

www.diodes.com