

PART NUMBER	ENGINEERING NO.	LENGTH ± TOLERANCE
1300270103	DNDF02A-M010	3' 3" +2.19"/-0" [1M +55.6/-0 mm]
1300270159	DNDF02A-M030	9' 10" +3.50"/-0" [3M +88.9/-0 mm]
1300270106	DNDF02A-M050	16' 5" +6.50"/-0" [5M +165.1/-0 mm]

AUX VIEW
SCALE 1:4

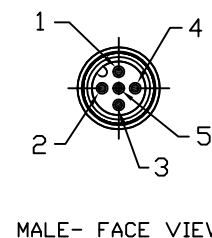
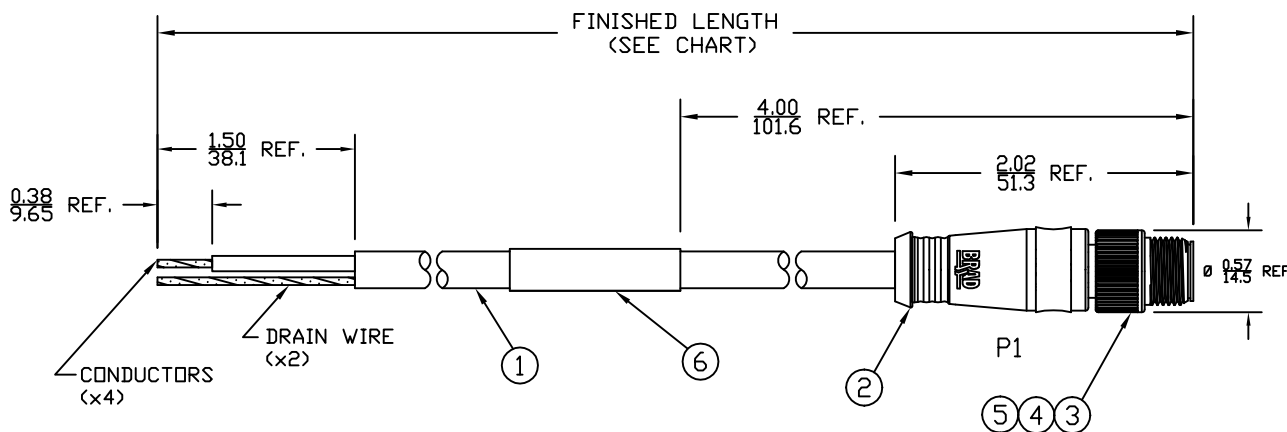
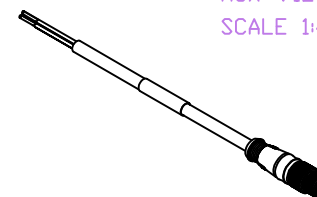

SCHEMATIC

P1

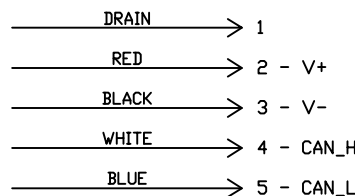

NOTES:

- MATERIAL: SEE TABLE
- FINISHES: SEE TABLE
- CABLE: #22/2, #24/2 + DRAIN, DEVICENET THIN HIGH FLEX
EACH PAIR: SHIELDED, TWISTED
OVERALL: SHIELDED, TPE
- ELECTRICAL DATA:
MAX. VOLTAGE: 250V AC/DC
MAX. CURRENT 4A
- ENVIRONMENTAL:
PROTECTION IP67
TEMPERATURE RANGE: -20°C TO 80°C
- WRAP LABEL IS MARKED WITH P/N, DATE CODE,
VOLTAGE & AMPERAGE.
- ASSEMBLY IS RoHS COMPLIANT.

ITEM	QTY.	DESCRIPTION	MATERIAL	FINISH
6	1	LABEL	PLASTIC FILM	BLACK/YELLOW
5	1	INSERT	NYLON	BLACK
4	5	PIN CONTACT	COPPER ALLOY	GOLD PLATED
3	1	M12 COUPLING NUT	ZINC DIE-CAST	BLACK
2	1	OVERMOLD	TPE	GRAY
1	1	DEVICENET CABLE	TPE JACKET	GRAY

SD RELEASE EC NO: WNA2010-0076 8/4/09 DRWN: VOU CHKD: BWOODMAN APPR: JFMURPHY 2009/08/10	QUALITY SYMBOLS ▽=0 ▽=0	GENERAL TOLERANCES (UNLESS SPECIFIED)		DIMENSION STYLE IN/MM		SCALE 3:4	DESIGN UNITS INCH	THIRD ANGLE PROJECTION	
		4 PLACES	±----	±----	DRAWN BY	DATE	TITLE M12 DEVICENET CABLE ASSY 5P MALE STRAIGHT #22/2 24/2 TPE -THIN FLX		
		3 PLACES	±----	±0.05	CHECKED BY	DATE	MOLEX INCORPORATED		
		2 PLACES	±----	±0.10	BWOODMAN	2009/07/31	MOLEX INCORPORATED		
1 PLACE	±----	±0.20	APPROVED BY	DATE	MOLEX INCORPORATED				
ANGULAR ±1/2°		DRAFT WHERE APPLICABLE MUST REMAIN WITHIN DIMENSIONS		MATERIAL NO. SEE CHART		DOCUMENT NO. SD-130027-004		SHEET NO. 1 OF 1	
SIZE A		THIS DRAWING CONTAINS INFORMATION THAT IS PROPRIETARY TO MOLEX INCORPORATED AND SHOULD NOT BE USED WITHOUT WRITTEN PERMISSION							

6

5

4

3

2

1

E

E

D

D

C

C

B

B

A

A

6

5

4

3

2

1