

PART NO. SEE CHART SD-90880E
 DWG. NO.

- NOTES :
- 26 AWG STRANDED TOPCOAT, INSULATION MATERIAL : GREY PVC.
 - U.L. RATINGS :
 TEMPERATURE : -20°C TO 105°C
 VOLTAGE : 300V MAX.
 FLAMMABILITY : VW-1
 STYLE No. 2651
 - CUT, STRIPPED AND RETAINED (7.0) / .28 EACH END.
 - POSITION ONE IDENTIFIED.

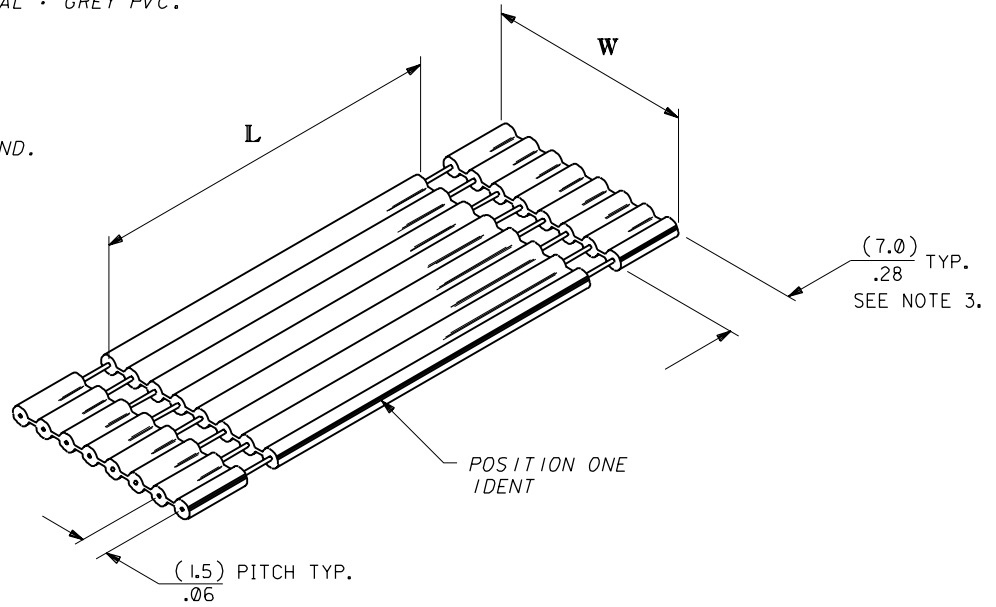

STANDARD LENGTHS (DIMENSION L)				
(50.0) 1.97	(70.0) 2.76	(100.0) 3.94	(150.0) 5.91	(200.0) 7.87

CKT. SIZE	DIM W (MAX)	CKT. SIZE	DIM W (MAX)
3	(4.5) / .18	8	(12.0) / .47
4	(6.0) / .24	9	(13.5) / .53
5	(7.5) / .30	10	(15.0) / .59
6	(9.0) / .35	11	(16.5) / .65
7	(10.5) / .41	12	(18.0) / .71

90880-****
 No OF CIRCUITS
 LENGTH L IN CENTIMETRES
 e.g. 05=5cm

FOR PREVIOUS DRAWING ISSUES SEE MRI.

ECN E90067 DRAWING RAISED 13.APR.89 PR	REVISIONS	DIMENSIONS SHOWN (METRIC) INCH UNLESS OTHERWISE SPECIFIED TOLERANCES: ANGULAR ± 1/2°	DRWG BY PR
		INCH (METRIC)	CHK'D BY
A	LTR	3 PLACE ± .	APP'D BY
		2 PLACE ± .	SCALE
		1 PLACE ±	
		DRAFT WHERE APPLICABLE MUST REMAIN WITHIN DIMENSIONS	
		DESIGN DIMENSION <input checked="" type="checkbox"/> (MM) <input type="checkbox"/> IN.	
		EQUIVALENT DIMENSION <input type="checkbox"/> (MM) <input checked="" type="checkbox"/> IN.	

REVISE ONLY ON CAD SYSTEM		SHL	REV.
CAD/CAM FILENAME SD90880X1 DCN		THIS DRAWING CONTAINS INFORMATION THAT IS PROPRIETARY TO MOLEX INC. & SHOULD NOT BE USED WITHOUT WRITTEN PERMISSION	
TITLE (1.5) / .059 PITCH ROUND CONDUCTOR FLAT CABLE JUMPER			
MOLEX MOLEX EUROPE		SHEET NO. DATE 1 OF 1 13/ 4/89	
PART NO. SEE CHART	DWG NO. SD-90880E	SIZE B	