

DO NOT SCALE FROM THIS PRINT

**PF** THIS PRODUCT MANUFACTURED WITH LEAD-FREE PROCESSING

**DESIGNED & DIMENSIONED IN MILLIMETERS [INCHES]**

TABLE 1		
ITEM	COMPONENT	-HF
1	FERRULE	MCX-FER-014-F
2	PIN	MCX-SKT-001-H
3	SUB ASSEMBLY	SUB-MCX-J-C-F-ST-CA1

**MCX-J-C-XX-ST-CA1S**

GENDER  
-J: JACK

TYPE  
-C: CABLE

TERMINATION

-CA1S: CABLE (RG-316 CABLE, DOUBLE SHIELD)

ORIENTATION

-ST: STRAIGHT

**PLATING SPECIFICATION**

-HF: 30μ" GOLD CENTER CONTACT, 3μ" GOLD OUTER CONTACT (SEE TABLE 1)

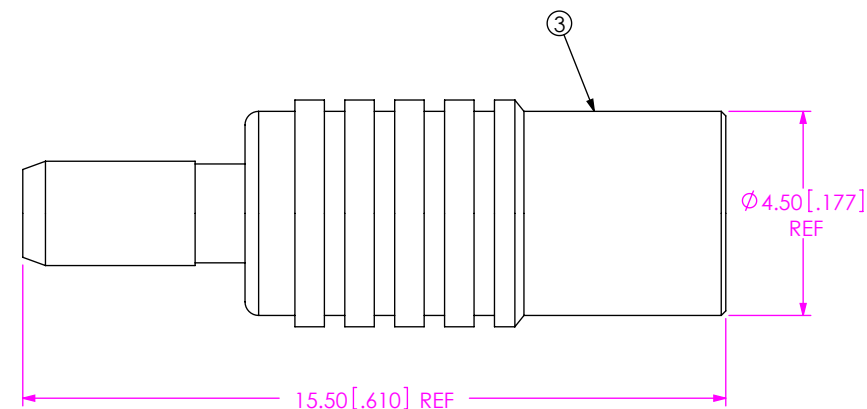
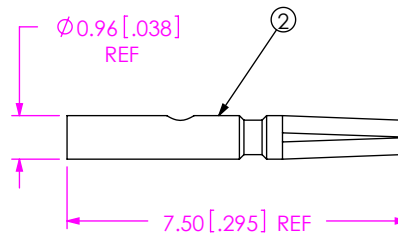
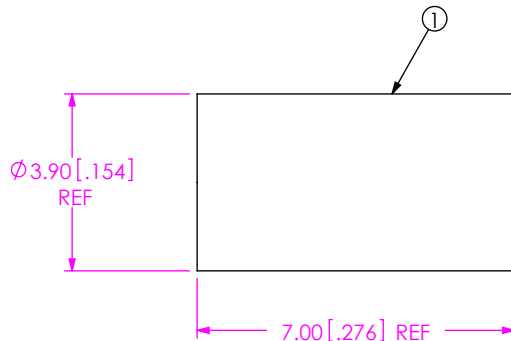

**NOTES:**

- ⊗ REPRESENTS A CRITICAL DIMENSION.
- CENTER CONTACT PUSHOUT FORCE: 10 N [2.25 LB] MIN.
- PRODUCT TO BE PACKAGED PER PACKAGING STANDARD CO-RF-WI-3040-M.
- PIN AND FERRULE TO BE PACKAGED SEPARATELY.

F:\DWG\MISC\MKTG\MCX-J-C-XX-ST-CA1S-MKT.SLDDRW

<p><b>UNLESS OTHERWISE SPECIFIED, DIMENSIONS ARE IN MILLIMETERS [INCHES].</b></p> <p><b>TOLERANCES ARE:</b></p> <p>DECIMALS      ANGLES</p> <p>.X: ±0.3 [0.1]      5°</p> <p>.XX: ±0.13 [0.05]</p> <p>.XXX: ±0.051 [0.020]</p>	<p><b>PROPRIETARY NOTE</b></p> <p>THIS DOCUMENT CONTAINS CONFIDENTIAL AND PROPRIETARY INFORMATION AND ALL DESIGN, MANUFACTURING, REPRODUCTION, USE, PATENT RIGHTS AND SALES RIGHTS ARE EXPRESSLY RESERVED BY SAMTEC, INC. THIS DOCUMENT SHALL NOT BE DISCLOSED, IN WHOLE OR PART, TO ANY UNAUTHORIZED PERSON OR ENTITY NOR REPRODUCED, TRANSFERRED OR INCORPORATED IN ANY OTHER PROJECT IN ANY MANNER WITHOUT THE EXPRESS WRITTEN CONSENT OF SAMTEC, INC.</p>
<p><b>MATERIAL:</b>      DO NOT SCALE DRAWING      SHEET SCALE: 6:1</p> <p>SHELL, FERRULE: BRASS CONTACT: COPPER ALLOY DIELECTRIC: PTFE</p>	<p>DESCRIPTION: MCX STRAIGHT CABLE JACK, RG 316, DOUBLE SHIELD, - 50 OHM</p> <p>DWG. NO. <b>MCX-J-C-XX-ST-CA1S</b></p> <p>BY: SHERRY W 09/23/2013      SHEET 1 OF 2</p>



520 PARK EAST BLVD, NEW ALBANY, IN 47150  
PHONE: 812-944-6733      FAX: 812-948-5047  
e-Mail: info@SAMTEC.com      code: 55322

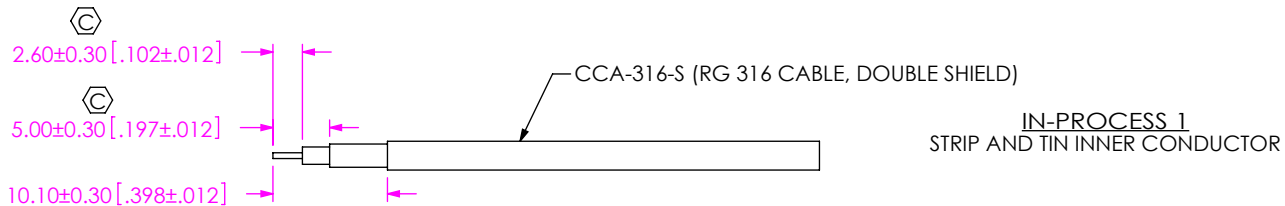

**IN-PROCESS 1**  
STRIP AND TIN INNER CONDUCTOR

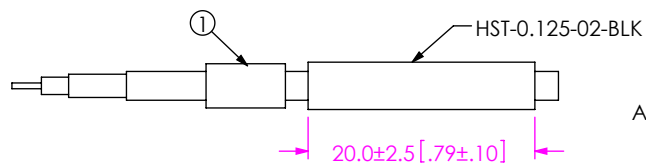

**IN-PROCESS 2**  
ADD HEAT SHRINK TUBE AND FERRULE

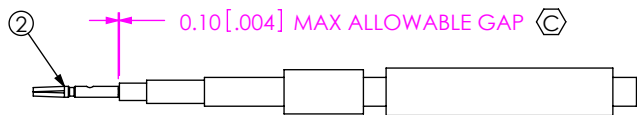

**IN-PROCESS 3**  
SOLDER SIGNAL SOCKET



**IN-PROCESS 4**  
FLARE SHIELD

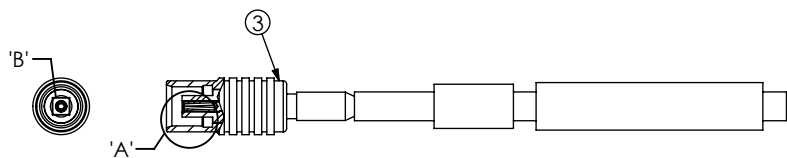

**IN-PROCESS 5**  
ADD SUB ASSEMBLY

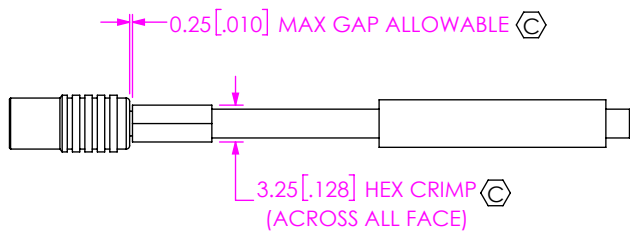

**IN-PROCESS 6**  
CRIMP FERRULE  
(USE RF CRIMP HAND TOOL # CAT-RF-FER-01)

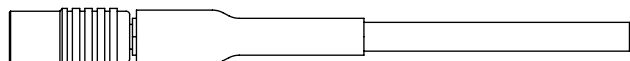

**IN-PROCESS 7**  
APPLY HEAT SHRINK TUBING

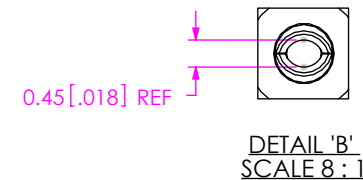
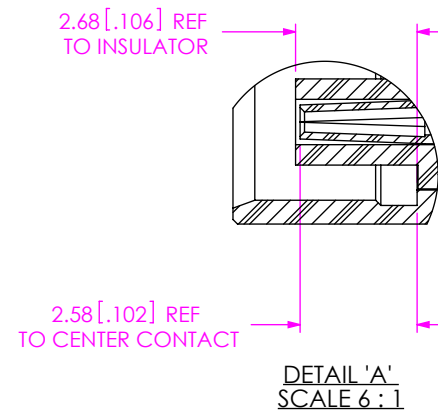

**PROPRIETARY NOTE**  
THIS DOCUMENT CONTAINS CONFIDENTIAL AND PROPRIETARY INFORMATION AND ALL DESIGN, MANUFACTURING, REPRODUCTION, USE, PATENT RIGHTS AND SALES RIGHTS ARE EXPRESSLY RESERVED BY SAMTEC, INC. THIS DOCUMENT SHALL NOT BE DISCLOSED, IN WHOLE OR PART, TO ANY UNAUTHORIZED PERSON OR ENTITY NOR REPRODUCED, TRANSFERRED OR INCORPORATED IN ANY OTHER PROJECT IN ANY MANNER WITHOUT THE EXPRESS WRITTEN CONSENT OF SAMTEC, INC.

DO NOT SCALE DRAWING

SHEET SCALE: 1:0.666667



520 PARK EAST BLVD, NEW ALBANY, IN 47150  
PHONE: 812-944-6733 FAX: 812-948-5047  
e-Mail: info@SAMTEC.com code: 55322

DESCRIPTION:  
MCX STRAIGHT CABLE JACK, RG 316, DOUBLE SHIELD, - 50 OHM

DWG. NO.  
**MCX-J-C-XX-ST-CA1S**

BY: SHERRY W 09/23/2013 SHEET 2 OF 2