

LOC	DIST	REV	DATE	BY	CHK	APPD
AD	00					

REV	DATE	BY	CHK	APPD
C	11FEB2004	RWS	RHW	
D	06FEB2007	BC	DB	
E	10JUL2008	DH	DB	
E1	26AUG2009	AEG	DD	

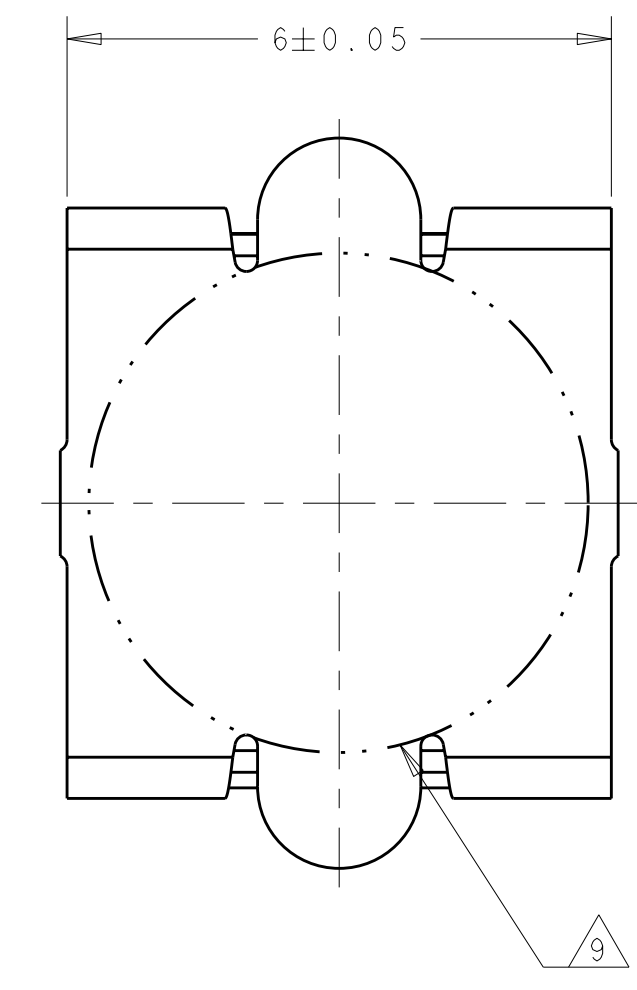
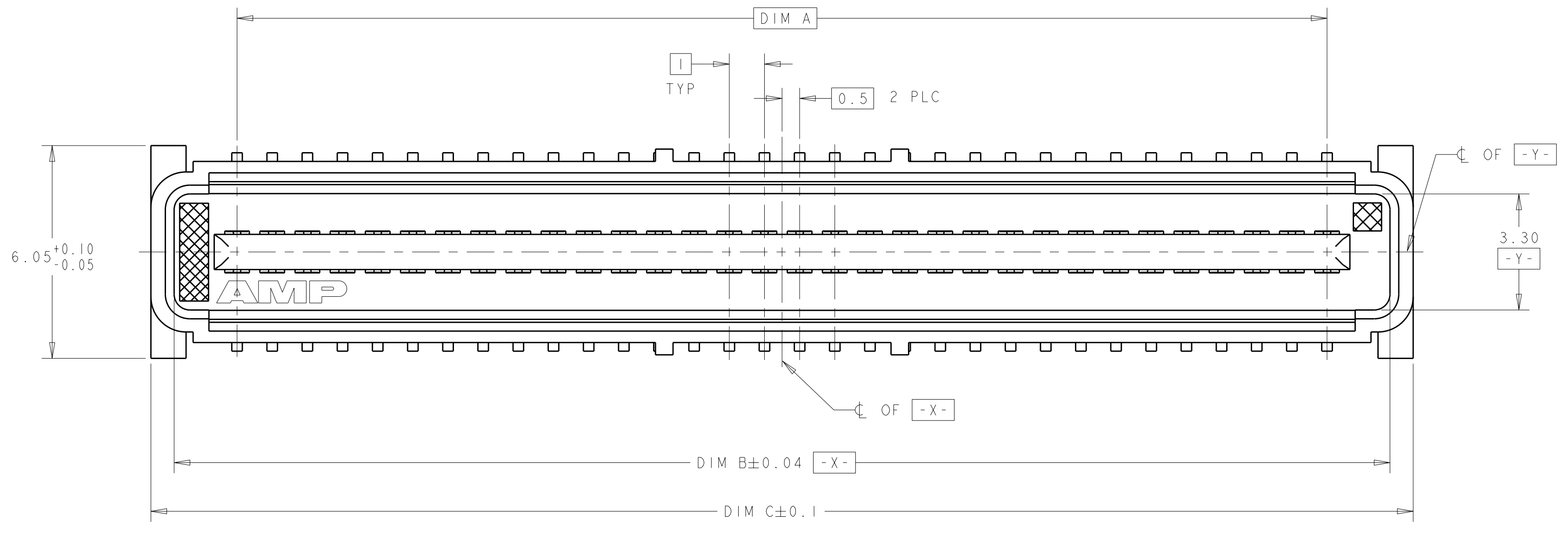

VACUUM COVER

- 1 HOUSING MATERIAL: LIQUID CRYSTAL POLYMER COLOR: BLACK. CONTACT MATERIAL: PHOSPHOR BRONZE.
- 2 CONTACT FINISH: NICKEL UNDERPLATE ALL OVER, MATING SURFACES PLATED TO MEET PLI PERFORMANCE REQUIREMENTS OF INDUSTRY SPECIFICATION EIA-700AAA, SOLDER TAILS PLATED TIN-LEAD.
- 3 DATUM LOCATIONS AND BASIC DIMENSIONS TO BE ESTABLISHED BY THE CUSTOMER. CONSULT AMP ENGINEERING WHEN PLACING MULTIPLE CONNECTORS ON A PC BOARD.
- 4 PACKAGED IN TAPE ON REELS PER EIA-481.
- 5 1.4±0.05 DIAMETER HOLE WHEN PLACING BY HAND.
- 6 SHORTER SOLDER LANDS MAY BE USED PER EIA 700AAA, HOWEVER 2.7 LENGTH ASSURES OPTIMUM SOLDER FILLET REGARDLESS OF MANUFACTURER OF CONNECTOR.
- 7 REFERRED TO AS DIM N IN EIA 700AAA SPECIFICATION.
- 8 VACUUM COVER NOT SHOWN IN SOME VIEWS FOR CLARITY.
- 9 5.5 MIN DIAMETER TARGET AREA FOR VACUUM PICK-UP.
- 10 CONTACT FINISH: 0.00381 MINIMUM MATTE TIN-LEAD (93-7) ON SOLDER AREA, 0.00127 MINIMUM GOLD ON MATING AREA, BOTH OVER 0.00127 MINIMUM NICKEL ON ENTIRE CONTACT.
- 11 SQUARE AND DIAMOND SHAPED POSTS.
- 12 ROUND SHAPED POSTS.

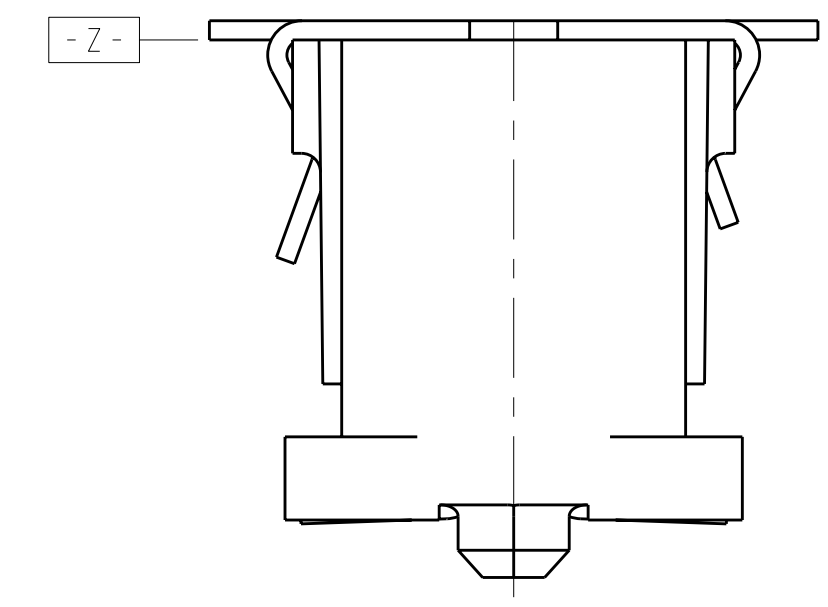
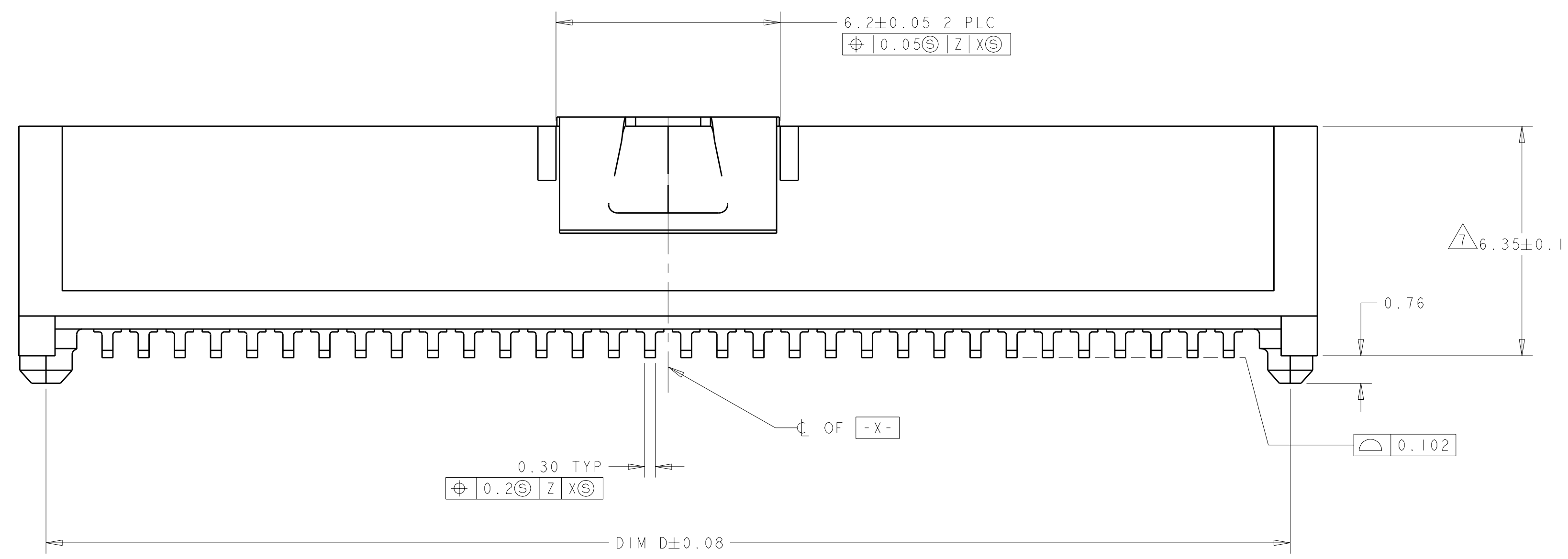

STYLE A POST

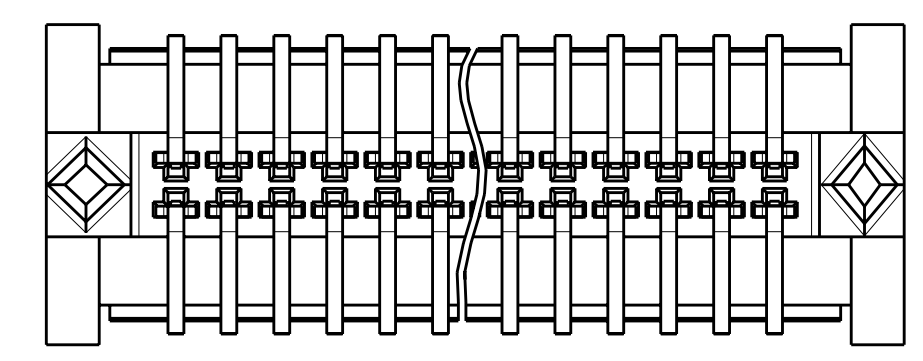

STYLE B POST

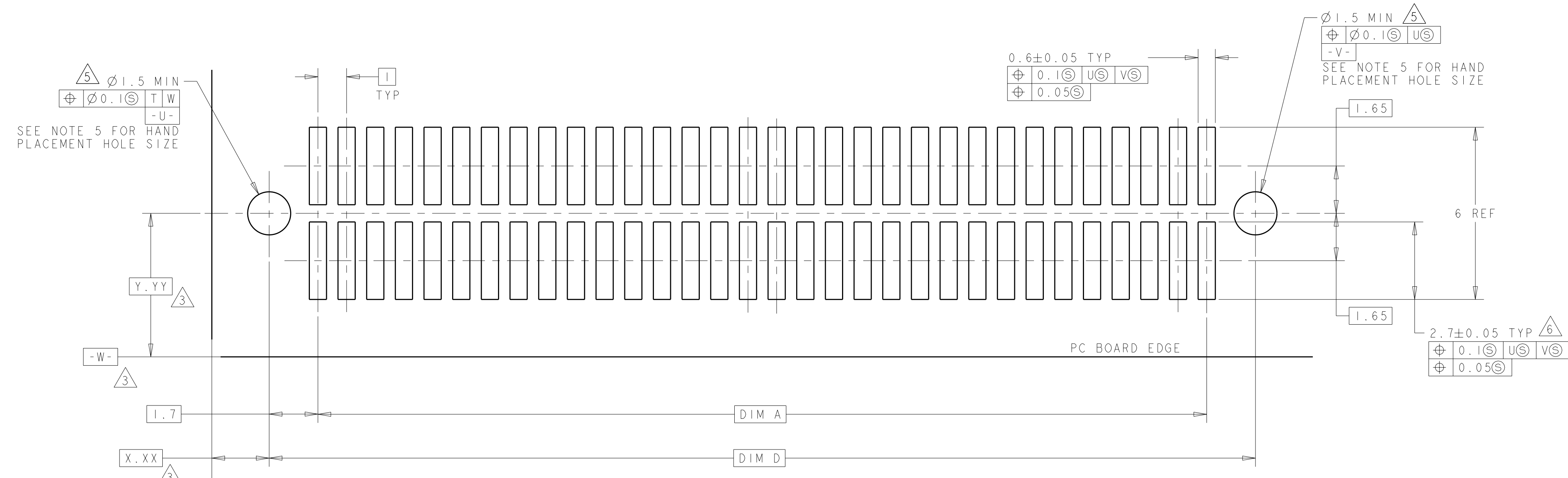
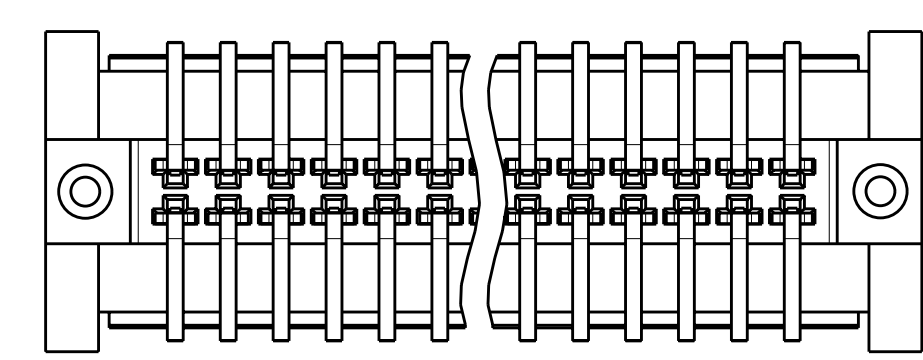

RECOMMENDED PC BOARD LAYOUT

POST STYLE	FINISH	DIM D	DIM C	DIM B	DIM A	STACK HEIGHTS	POS	AMP PART NUMBER
△	△	44.4	45.9	44.58	41	8	84	3-146897-2
△	△	34.4	35.9	34.58	31	8	64	3-146897-1
△	△	44.4	45.9	44.58	41	8	84	2-146897-2
△	△	34.4	35.9	34.58	31	8	64	2-146897-1
△	△	44.4	45.9	44.58	41	8	84	1-146897-2
△	△	34.4	35.9	34.58	31	8	64	1-146897-1
△	△	44.4	45.9	44.58	41	8	84	146897-2
△	△	34.4	35.9	34.58	31	8	64	146897-1

DIMENSIONS: mm 9 PLC ± 5 PLC ±0.03 4 PLC ±0.003 4 PLC ± ANGLES ±0°30'		TOLERANCES UNLESS OTHERWISE SPECIFIED: DIMENSIONS: mm 9 PLC ± 5 PLC ±0.03 4 PLC ±0.003 4 PLC ± ANGLES ±0°30'		DWN: DK_SCHURM 28SEP98 CHN: CHAD_BAKER 28SEP98 NAME:		Tyco Electronics Corporation Harrisburg, PA 17105-3608	
MATERIAL: SEE TABLE		PRODUCT SPEC: 502-1079 APPLICATION SPEC: 114-25045		PLUG ASSY, W/VACUUM COVER, 1.0mm FH(1EEE 1386) CONNECTOR		SIZE: 00779 C=146897	
CUSTOMER DRAWING		WEIGHT:		SCALE: 17:1		SHEET 1 OF 1 REV E	