

I²C bus line buffer IC

BA8274 / F

BA8274, BA8274F are buffer ICs that can lengthen the bus line retaining all features and operating mode of I²C bus system. Adoption of this buffer in data and clock line enable to improve the drive capacity and to lengthen the bus line with using standard wire at a low price.

●Applications

Mini-component stereo, Micro-component stereo and Television.

●Features

- 1) Dual, bi-directional, unity voltage gain buffer.
- 2) I²C bus compatible.
- 3) 1:10 impedance transformation.
- 4) Logic signal levels may include both supply and ground.
- 5) Power supply voltage range is large.

●Absolute maximum ratings (Ta=25°C)

Parameter	Symbol	Limits	Unit
Power supply voltage	V _{CC}	13.0	V
Power dissipation	P _d	800* / 550*	mW
Operating temperature	T _{opr}	-40 to +85	°C
Storage temperature	T _{stg}	-55 to +125	°C

* For Ta=25°C or more it is reduced at 5.5mW/°C(SOP), 8.0mW/°C (DIP).

●Recommended operating conditions (Ta=25°C)

Parameter	Symbol	Min.	Typ.	Max.	Unit
Power supply voltage	V _{CC}	4.5	-	12	V

* I²C bus is a trademark of Philips.

Audio ICs

●Block diagram

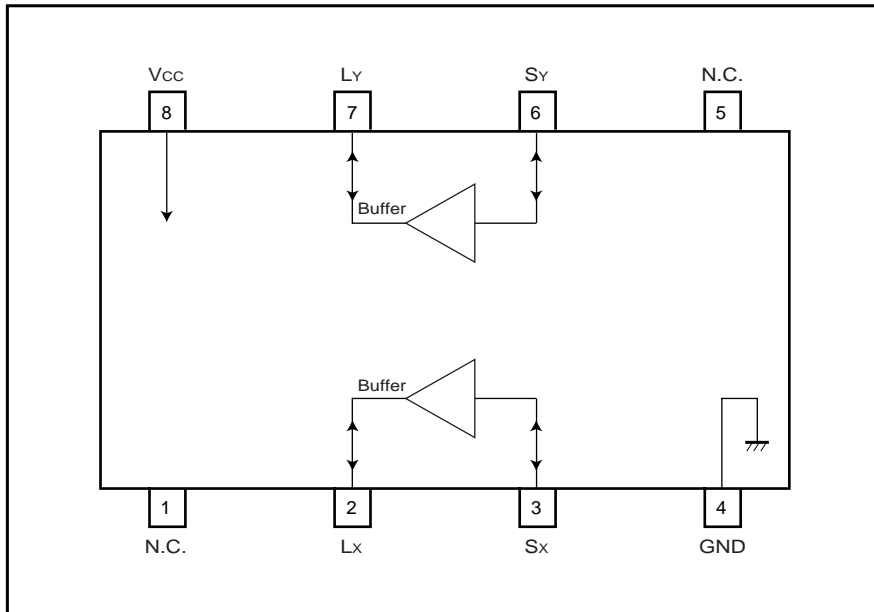

●Pin descriptions and input output circuits

Pin No.	Pin Name	Equivalent circuit	Pin description
2 7	Lx Ly		A pin for outputting a buffer.
3 6	Sx Sy		A pin for inputting a buffer.
4	GND	—	A ground pin.
8	Vcc	—	Power supply pin.

Audio ICs

●Electrical characteristics (unless otherwise noted, Ta=25°C, Vcc=5V)

Parameter	Symbol	Min.	Typ.	Max.	Unit	Conditions
Supply current 1	I _{Q1}	–	16	30	mA	
Supply current 2	I _{Q2}	–	17	30	mA	V _{CC} =12V
Supply current 3	I _{Q3}	–	30	40	mA	Both I ² C inputs LOW, both buffered outputs sinking 30mA.
Drive current 1	I _{SX} , I _{SY}	2.0	2.7	–	mA	I _{SX} , I _{SY} LOW=0.4V V _{LX} , V _{LY} LOW on buffered bus=0.3V.
Drive current 2	I _{LX} , I _{LY}	20	27	–	mA	I _{LX} , I _{LY} LOW=0.4V V _{SX} , V _{SY} LOW on I ² C bus=0.3V.
Input current 1	I _{SX} , I _{SY}	–	2.8	3.5	mA	I _{LX} , I _{LY} sink on buffered bus=30mA.
Input current 2	I _{LX} , I _{LY}	–	3.0	3.3	mA	I _{SX} , I _{SY} sink on I ² C bus=3mA.
Leakage current	I _{LX} , I _{LY}	–	–	200	∞A	V _{LX} , V _{LY} =V _{CC} and V _{SX} , V _{SY} =V _{CC} .
Input/Output impedance	Z _{IN} / Z _{OUT}	8	10	13	–	

●Measurement circuit

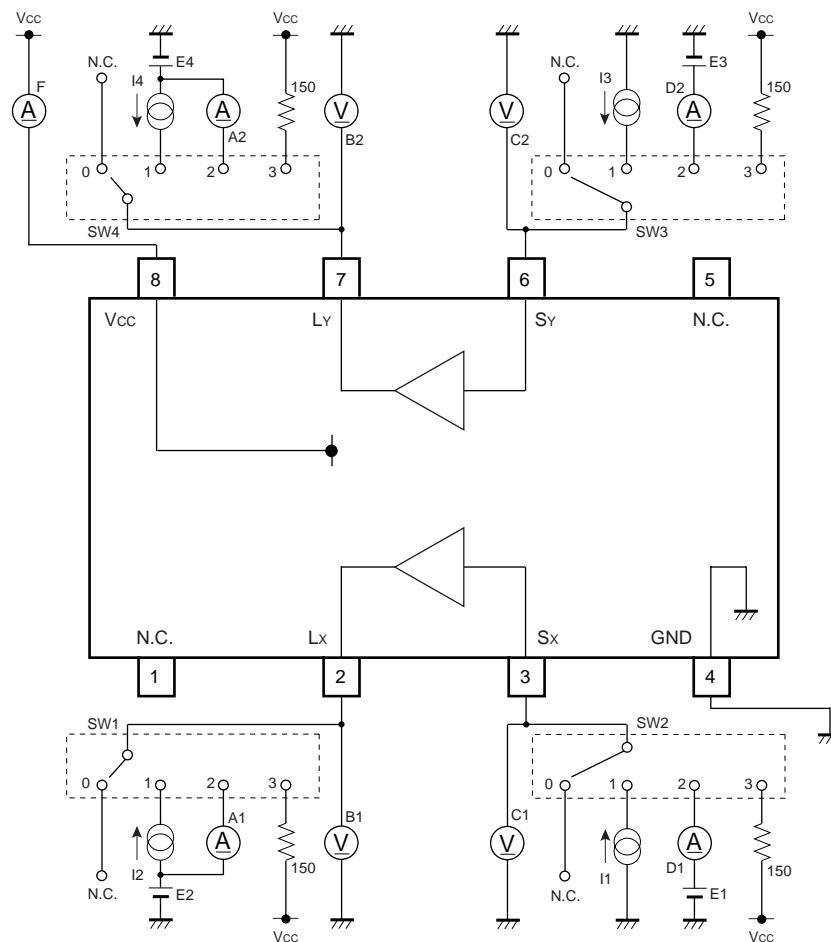

Fig.1

Audio ICs

●Circuit operation

BA8274/F contains two identical buffer circuits which enable I²C and similar bus systems to be extended over long distances without degradation of system performance or requiring the use of special cables.

The buffer has an effective current gain of about 10 from I²C bus to buffered bus. When current is flowing out of the I²C bus side, about 10 times that current will be flowing into the buffered bus side (See Fig.2).

As a consequence of this amplification the system is able to drive capacitive load up to about 6 times the standard limit on the buffered bus side. This current based buffering approach preserves the bi-directional, open collector / open-drain characteristic of the I²C SDA/SCL lines.

To minimize interference and ensure stability, current rise and fall rates are internally controlled.

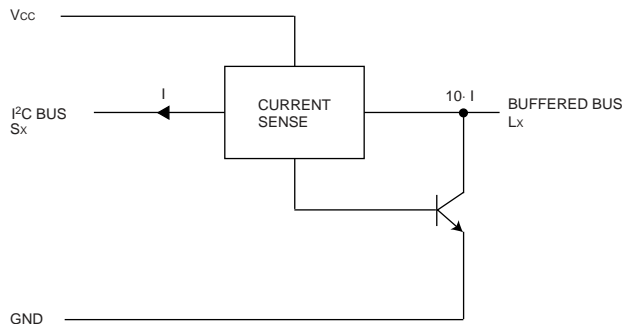

Fig.2

●Application circuit

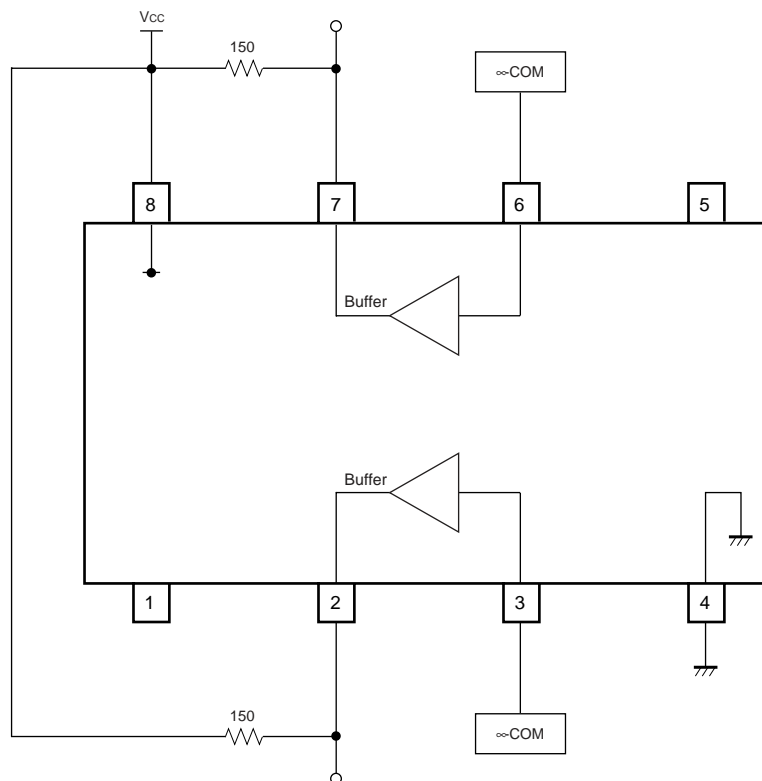

Fig.3

Audio ICs

●Attached components

1. Selection of external components

(1) Pull-up resistance calculation

In practical system the pull-up resistance is determined by the rise time limit for I²C systems. As an approximation this limit will be satisfied if the time constant (product of the net resistance and net capacitance) of the total system is set to 1 microsecond.

The total time constant may either be set by considering each bus node individually (i.e., the I²C nodes, and the buffered bus node) and choosing pull-up resistors to give time constants of 1 microsecond for each node; or by combining the capacitances into an equivalent capacitive loading on the buffered bus, and calculating the buffered bus

pull-up resistor required by this equivalent capacitance.

For each separate bus the pull-up resistor may be calculated as follows:

$$R = \frac{1 \mu\text{sec}}{C_{\text{device}} + C_{\text{wiring}}}$$

Where : C_{device} = Sum of device capacitances connected to each bus.

C_{wiring} = Total wiring and stray capacitance on each bus.

If these capacitances are not know then a good approximation is to assume that each device presents 10pF of load capacitance and 10pF of wiring capacitance.

The capacitance figures for one or more individual I²C bus nodes should be multiplied by a factor of about 10 times, and then added to the buffered bus capacitance. Calculation of a new buffered bus pull-up resistor will allow this single pull-up resistor to act for both the included I²C bus nodes and the buffered bus. Thus it is possible to combine some or all of these separate pull-up resistors into a signal resistor on the buffered bus (the value of which is calculated from the sum of the scaled capacitances on the buffered bus.) If the buffer is to be permanently connected into the system then all the separate pull-up resistors should be combined. But if it is to be connected by adding it onto an existing system, then only those on the additional I²C bus system can be combined onto to the buffered bus if the original system is required to be able to still operate on a stand-alone basis.

A further restriction is that the maximum pull-up current, with the bus LOW, should not exceed the I²C bus specification

maximum of 3mA, or 30mA on buffered bus. The following formula applies:

$$30\text{mA} > \frac{V_{\text{CC}} - 0.4}{R_{\text{p}}}$$

Where : R_p = Scaled parallel combination of all pull-up resistors.

If this condition is met, the fall time specifications will also be met.

Audio ICs

2. Loading calculations for the expanded I²C bus.

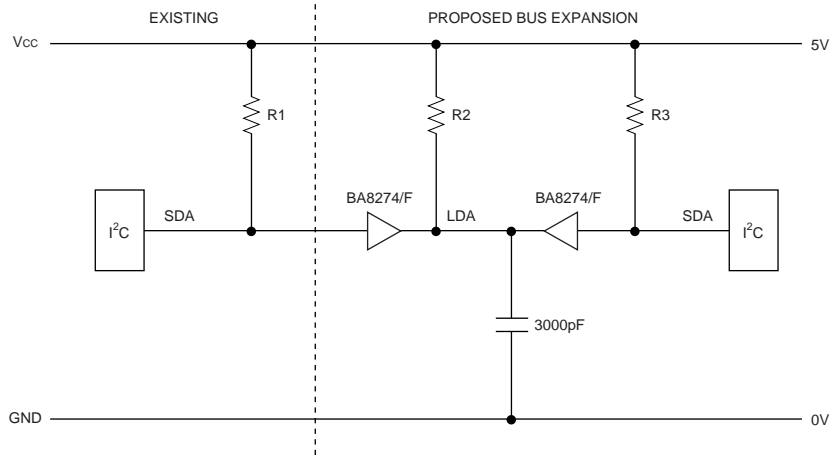

Fig.4

Effective capacitance
Near I²C devices

2 · I ² C Devices	20pF
Strays	20pF
BA8274 Buffer	10pF
Total Cap.	50pF

I²C pull-up

$$R1 = \frac{1 \infty \text{sec}}{50 \text{pF}} = 20 \text{k}\Omega$$

Effective capacitance
Buffered line

Wiring Cap.	3000pF
Total Cap.	3000pF

Buffered bus pull-up

$$R2 = \frac{1 \infty \text{sec}}{3000 \text{pF}} = 333 \text{k}\Omega$$

Effective capacitance
Remote I²C devices

1 · I ² C Devices	10pF
Strays	10pF
BA8274 Buffer	10pF
Total Cap.	30pF

I²C pull-up

$$R3 = \frac{1 \infty \text{sec}}{30 \text{pF}} = 33 \text{k}\Omega$$

As an addition to an existing system:

$$R1 = 20 \text{k}\Omega \quad R2 = \frac{R2 \cdot 0.1R3}{R2 + 0.1R3} = 300 \Omega$$

R3 not required since buffer always connected.

For a permanent system:

$$R2 = \frac{1}{\frac{1}{0.1R1} + \frac{1}{0.1R2} + \frac{1}{0.1R3}} = 262 \Omega$$

R1 and R3 not required since buffer always connected.

Audio ICs

Note): R1, R2 and R3 are calculated from the capacitive loading and a 1μsec time constant on each bus node. For an addition to an existing system, R2 (the new value for R2) is shown as being calculated from the parallel combination of R2 and the scaled value of R3; while for a permanent system R2, and scaled values of R1 and R3 have been used. Note that this example has used scaled resistor values and combined the node and cable capacitances.

Check for maximum pull-up current:

$$\frac{(5-0.4)V}{260\Omega} = 17.6\text{mA} < 30\text{mA}$$

●Operation notes

1. About operation voltage supply range

Within operation voltage supply range, basic circuit function operation is guaranteed within operation ambient temp.

But please confirm set up of constant and element, voltage set up and temp set up on use.

2. About operation temp range

If it within recommended operation voltage range, circuit function operation is guaranteed within operation temp.

It corralled to conditions of power dissipation to temp.

Please watch out except condition stipulated by electrical characteristics within the range, it cannot guarantee standard value of electrical characteristics. But it retains original function.

3. S_x, S_y, I²C BUS, SDA or SCL

Because the two buffer circuits in the BA8274/F are identical either input pin can be used as the I²C BUS SDA data line,

or the SCL clock line.

4. L_x, L_y, Buffered bus, LDA or LCL

On the buffered low impedance line side, the corresponding output becomes LDA and LCL.

●Electrical characteristic curves

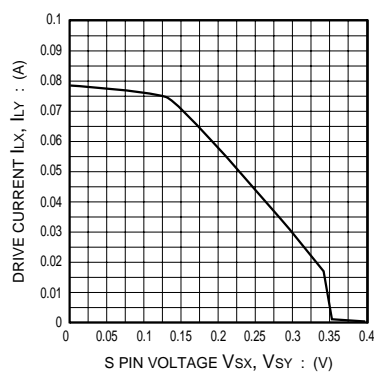
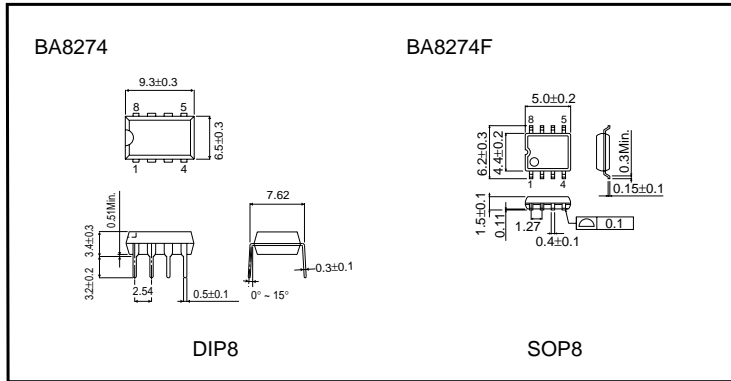

Fig.5 S pin voltage-drive current I_x, I_y

Audio ICs

●External dimensions (Unit: mm)



Notes

- No technical content pages of this document may be reproduced in any form or transmitted by any means without prior permission of ROHM CO.,LTD.
- The contents described herein are subject to change without notice. The specifications for the product described in this document are for reference only. Upon actual use, therefore, please request that specifications to be separately delivered.
- Application circuit diagrams and circuit constants contained herein are shown as examples of standard use and operation. Please pay careful attention to the peripheral conditions when designing circuits and deciding upon circuit constants in the set.
- Any data, including, but not limited to application circuit diagrams information, described herein are intended only as illustrations of such devices and not as the specifications for such devices. ROHM CO.,LTD. disclaims any warranty that any use of such devices shall be free from infringement of any third party's intellectual property rights or other proprietary rights, and further, assumes no liability of whatsoever nature in the event of any such infringement, or arising from or connected with or related to the use of such devices.
- Upon the sale of any such devices, other than for buyer's right to use such devices itself, resell or otherwise dispose of the same, no express or implied right or license to practice or commercially exploit any intellectual property rights or other proprietary rights owned or controlled by
- ROHM CO., LTD. is granted to any such buyer.
- Products listed in this document use silicon as a basic material.
Products listed in this document are no antiradiation design.

The products listed in this document are designed to be used with ordinary electronic equipment or devices (such as audio visual equipment, office-automation equipment, communications devices, electrical appliances and electronic toys).

Should you intend to use these products with equipment or devices which require an extremely high level of reliability and the malfunction of which would directly endanger human life (such as medical instruments, transportation equipment, aerospace machinery, nuclear-reactor controllers, fuel controllers and other safety devices), please be sure to consult with our sales representative in advance.

About Export Control Order in Japan

Products described herein are the objects of controlled goods in Annex 1 (Item 16) of Export Trade Control Order in Japan.

In case of export from Japan, please confirm if it applies to "objective" criteria or an "informed" (by MITI clause) on the basis of "catch all controls for Non-Proliferation of Weapons of Mass Destruction.