

C30619, C30641, C30642, C30665 and C30723 Series Large Area InGaAs PIN Photodiodes



Excelitas' Large Area PIN Diodes are highly sensitive, low capacitance InGaAs diodes that provide high responsivity from 800 nm to 1700 nm. An ultra-low capacitance version for high bandwidth applications is available upon request.

Key Features

- Ultra-low capacitance option
- High responsivity at 1300 nm and 1550 nm
- Active Area diameter from 0.5 mm to 5 mm
- High linearity over large dynamic range
- Available in various, robust TO packages
- Customizations (e.g. TEC attachment) possible
- RoHS compliant

Applications

- Optical Power Meter
- Fiber Optic Test Communication
- Near-IR spectroscopy
- Laser profiling stations
- Instrumentation
- LiDAR

All specifications are referring to an ambient temperature of $T_A = 22\text{ }^\circ\text{C}$, $\lambda = 1550\text{ nm}$ and typical V_{OP} .

Table 1: Key parameters

Parameter	Symbol	Min	Typ	Max	Unit
Operating Voltage ¹	V_{OP}	0	5	$V_{BD} - 5\text{ V}$	V
Spectral Range	$\Delta\lambda$	800		1700	nm
Peak Responsivity	λ_{peak}		1550		nm
Responsivity	R_{850}	0.10	0.20		A/W
	R_{1300}	0.80	0.90		
	R_{1550}	0.95	1.05		

Note 1: The depletion voltage can be substantial higher. To find the best operation point, refer to Figure 8 or contact our experts at Excelitas Technologies.

C30619, C30641, C30642, C30665 and C30723 Series

Large Area InGaAs PIN Photodiodes

Table 2: Ordering Information

Parameter	C30619GH	C30641GH	C30642GH	C30665GH	C30723GH
Active Area Shape	Circular				
Useful Area	0.2 mm ²	0.8 mm ²	3.1 mm ²	7.0 mm ²	19.6 mm ²
Useful Diameter	0.5 mm	1.0 mm	2.0 mm	3.0 mm	5.0 mm
Ultra-low capacitance	C30619GH-LC	C30641GH-LC	C30642GH-LC	C30665GH-LC	
Single Stage TEC ^{1,3}	C30619GH-TC	C30641GH-TC	C30642GH-TC	C30665GH-TC	
Double Stage TEC ^{2,3}	C30619GH-DTC	C30641GH-DTC	C30642GH-DTC	C30665GH-DTC	
Package Type	TO-18		TO-5		TO-8
-TC / -DTC Package	TO-66 flange outline				
Window Type	Flat Glass				

Note 1: The single stage TEC cools the diode chip to typically 0 °C.

Note 2: The double stage TEC cools the diode chip to typically -20 °C.

Note 3: Adding a TEC to the PIN diode will significantly reduce dark current, dark noise and NEP.

Only available upon special request. Contact our experts at Excelitas for further information.

Table 3: Absolute Maximum Ratings

Parameter	Symbol	Value	Units
Average Forward Current	I _F	10	mA
Total Power dissipation	P _{tot}	100	mW
Average Photocurrent	I _p	100	mA
Storage Temperature	T _S	-60 ... 125	°C
Operating Temperature	T _{Op}	-40 ... 85	°C
Soldering Temperature ³	T _p	260	°C

Note 1: Stresses above those listed under “Absolute Maximum Ratings” may cause permanent damage to the device.

Note 2: Exposure to absolute maximum rating conditions for extended periods may affect device reliability.

Note 3: 5 seconds, leads only

C30619, C30641, C30642, C30665 and C30723 Series

Large Area InGaAs PIN Photodiodes

Table 4: Optical Specifications

Parameter	Symbol	Device	Minimum	Typical	Maximum	Units
Rise Time / Fall Time ¹	t_r / t_f	C30619GH		1		ns
		C30619GH-LC		0.5		
		C30641GH		5		
		C30641GH-LC		2		
		C30642GH		17		
		C30642GH-LC		9		
		C30665GH		35		
		C30665GH-LC		17		
		C30723GH		117		
Bandwidth	f_{3dB}	C30619GH		350		MHz
		C30619GH-LC		700		
		C30641GH		75		
		C30641GH-LC		150		
		C30642GH		20		
		C30642GH-LC		40		
		C30665GH		10		
		C30665GH-LC		20		
		C30723GH		3		

Note 1: As estimated by $t_{r/f} = \frac{0.35}{f_{3dB}}$

The following notes apply for all electrical specifications:

Note 1: Dark current measurements are done at $V_{OP} = 5$ V on C30619GH, C30641GH, C30642GH and C30665GH. On the C30723GH $V_{OP} = 1$ V.

Note 2: Due to the natural fluctuations of charge carriers the PIN diode will also generate noise when not illuminated. Since the noise characteristics and hence the signal-to-noise ratio (SNR) are dependant on the bandwidth (f_{3dB}) and operating wavelength (λ) inside the final system the illuminated noise

$$i_{ill} = \sqrt{2qf_{3dB}(i_D + R(\lambda)P)}$$

needs to be considered. Hence the SNR is defined as

$$SNR = \frac{i_p^2}{i_{ill}^2} = \frac{(PR(\lambda))^2}{i_{ill}^2}$$

with q the charge carrier and P the incident optical power in W.

Note 3: The NEP is specified in dark conditions and defined as $NEP = \frac{i_N}{R(\lambda)}$

Note 4: Measured at $V_{OP} = 10$ mV. Selected devices with higher shunt resistance are available to special order. Contact our experts at Excelitas.

C30619, C30641, C30642, C30665 and C30723 Series

Large Area InGaAs PIN Photodiodes

Table 5: Electrical Specification C30619GH, C30619GH-LC, C30619GH-TC/(-DTC)

Parameter	Symbol	Minimum	Typical	Maximum	Units
Breakdown Voltage	V_{BD}	20			V
Capacitance, standard version	C_{0V}		15		pF
	C_{5V}		7		
	C_{25V}		6		
Capacitance, ultra-low option	$C_{0V,LC}$		15		pF
	$C_{5V,LC}$		5		
	$C_{25V,LC}$		2		
Dark Current ¹	i_D		0.3	20	nA
Dark Noise ²	i_N		0.02	0.10	pA/√Hz
Noise Equivalent Power ³	NEP ₈₅₀		100		fW/√Hz
	NEP ₁₃₀₀		22		
	NEP ₁₅₅₀		19		
Shunt Resistance ⁴	R_S	10			MΩ

Table 6: Electrical Specification C30641GH, C30641GH-LC, C30641GH-TC/(-DTC)

Parameter	Symbol	Minimum	Typical	Maximum	Units
Breakdown Voltage	V_{BD}	20			V
Capacitance, standard version	C_{0V}		60		pF
	C_{5V}		22		
	C_{25V}		20		
Capacitance, ultra-low option	$C_{0V,LC}$		60		pF
	$C_{5V,LC}$		18		
	$C_{25V,LC}$		9		
Dark Current ¹	i_D		1	50	nA
Dark Noise ²	i_N		0.04	0.15	pA/√Hz
Noise Equivalent Power ³	NEP ₈₅₀		200		fW/√Hz
	NEP ₁₃₀₀		44		
	NEP ₁₅₅₀		38		
Shunt Resistance ⁴	R_S	5			MΩ

C30619, C30641, C30642, C30665 and C30723 Series

Large Area InGaAs PIN Photodiodes

Table 7: Electrical Specification C30642GH, C30642GH-LC, C30642GH-TC/(-DTC)

Parameter	Symbol	Minimum	Typical	Maximum	Units
Breakdown Voltage	V_{BD}	15			V
Capacitance, standard version	C_{0V}		400		pF
	C_{5V}		90		
	C_{25V}		75		
Capacitance, ultra-low option	$C_{0V,LC}$		300		pF
	$C_{5V,LC}$		77		
	$C_{25V,LC}$		36		
Dark Current ¹	i_D		2		nA
Dark Noise ²	i_N		0.03	0.15	pA/√Hz
Noise Equivalent Power ³	NEP ₈₅₀		150		fW/√Hz
	NEP ₁₃₀₀		33		
	NEP ₁₅₅₀		29		
Shunt Resistance ⁴	R_S	2			MΩ

Table 8: Electrical Specification C30665GH, C30665GH-LC, C30665GH-TC/(-DTC)

Parameter	Symbol	Minimum	Typical	Maximum	Units
Breakdown Voltage	V_{BD}	10			V
Capacitance, standard version	C_{0V}		530		pF
	C_{5V}		200		
	C_{25V}		170		
Capacitance, ultra-low option	$C_{0V,LC}$		530		pF
	$C_{5V,LC}$		165		
	$C_{25V,LC}$		77		
Dark Current ¹	i_D		5		nA
Dark Noise ²	i_N		0.04	0.20	pA/√Hz
Noise Equivalent Power ³	NEP ₈₅₀		200		fW/√Hz
	NEP ₁₃₀₀		44		
	NEP ₁₅₅₀		38		
Shunt Resistance ⁴	R_S	1			MΩ

Table 9: Electrical Specification C30723GH

Parameter	Symbol	Minimum	Typical	Maximum	Units
Breakdown Voltage	V_{BD}	10			V
Capacitance	C_{2V}		950		pF
Dark Current ¹	i_D		20		nA
Shunt Resistance ⁴	R_S	1			MΩ

C30619, C30641, C30642, C30665 and C30723 Series Large Area InGaAs PIN Photodiodes

Table 9: Mechanical Dimensions

Figure 1: C30619GH

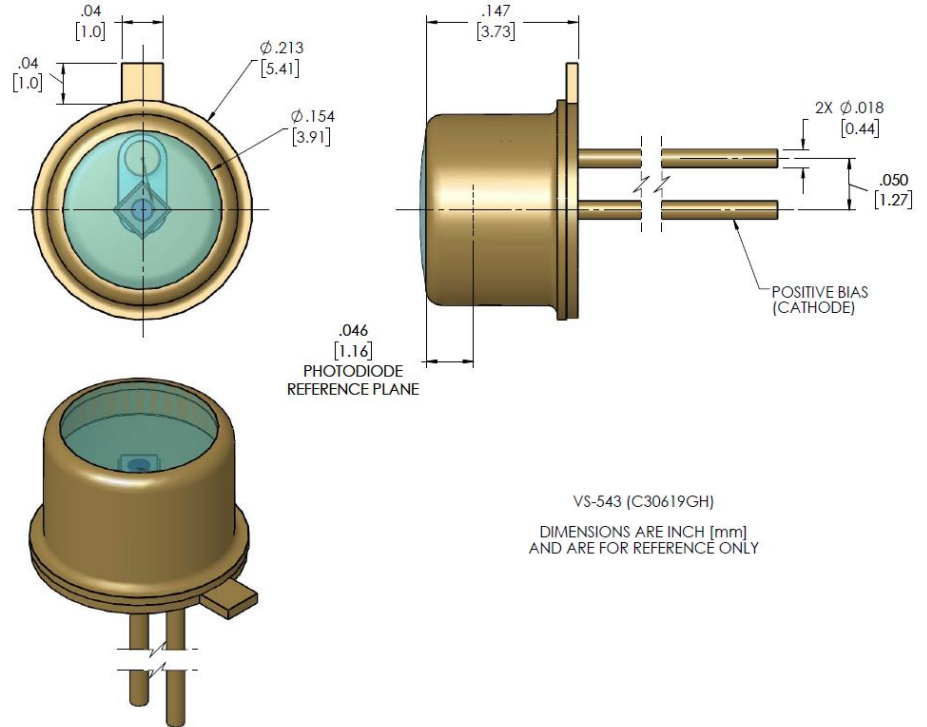
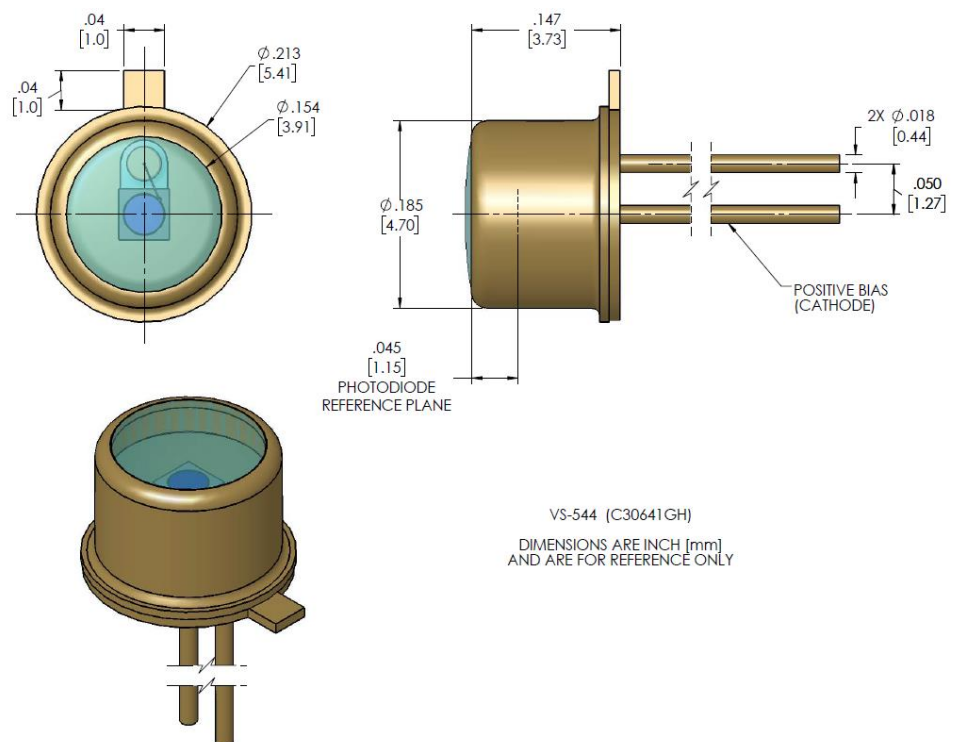
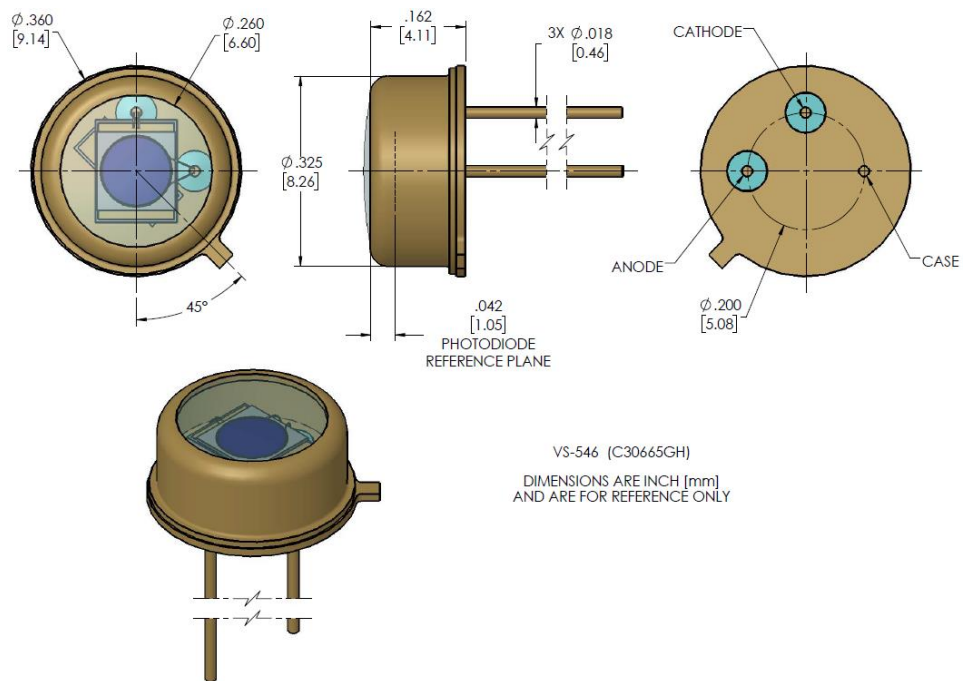
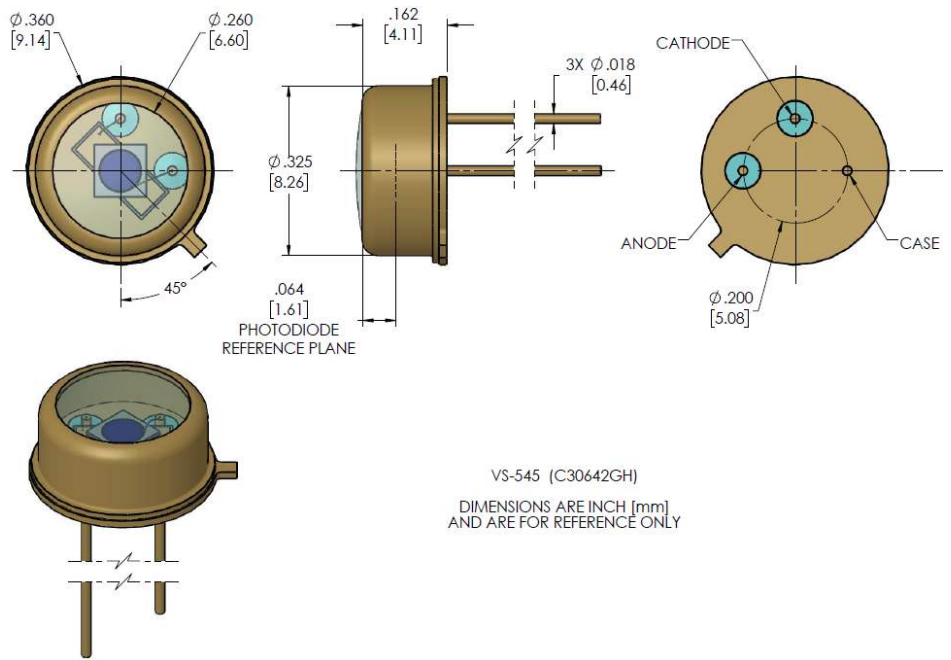

Figure 2: C30641GH



C30619, C30641, C30642, C30665 and C30723 Series
Large Area InGaAs PIN Photodiodes



C30619, C30641, C30642, C30665 and C30723 Series

Large Area InGaAs PIN Photodiodes



Figure 5: C30723GH

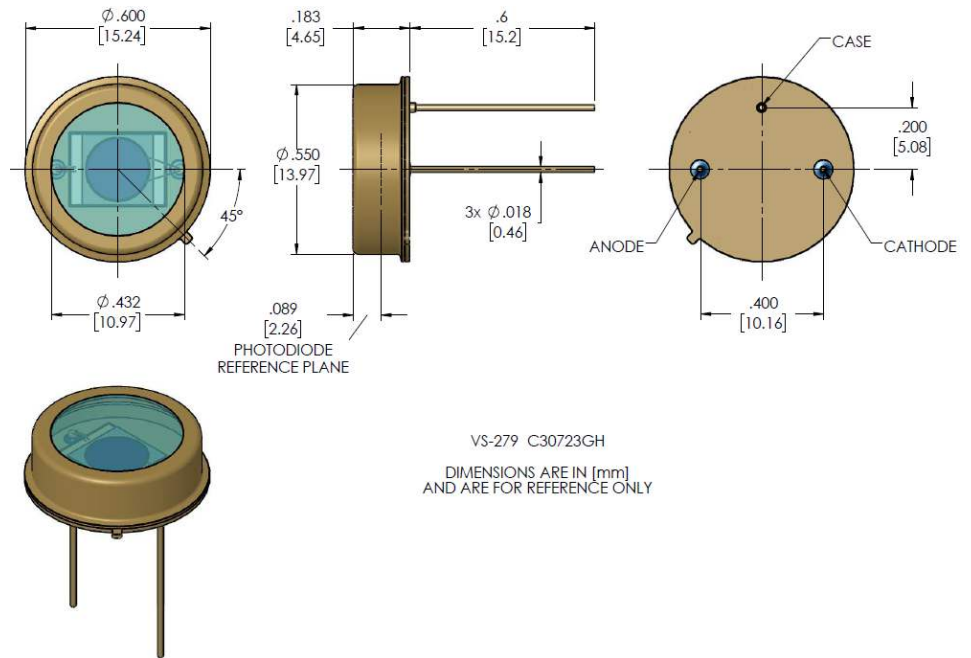
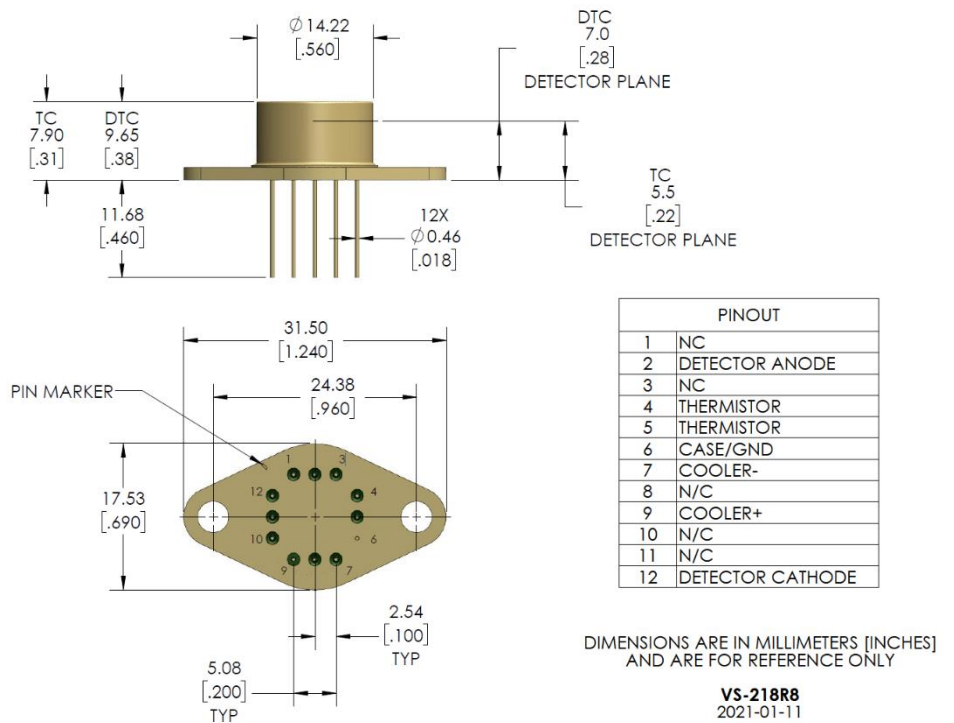

Figure 6: -TC / -DTC Package



C30619, C30641, C30642, C30665 and C30723 Series

Large Area InGaAs PIN Photodiodes

Figure 7: Typical Quantum Efficiency and Typical Responsivity vs. Wavelength

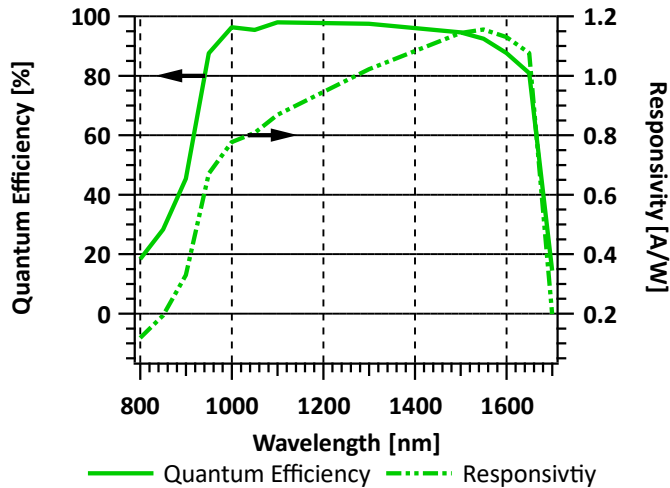

Figure 8: Typical Dark Current vs. Temperature

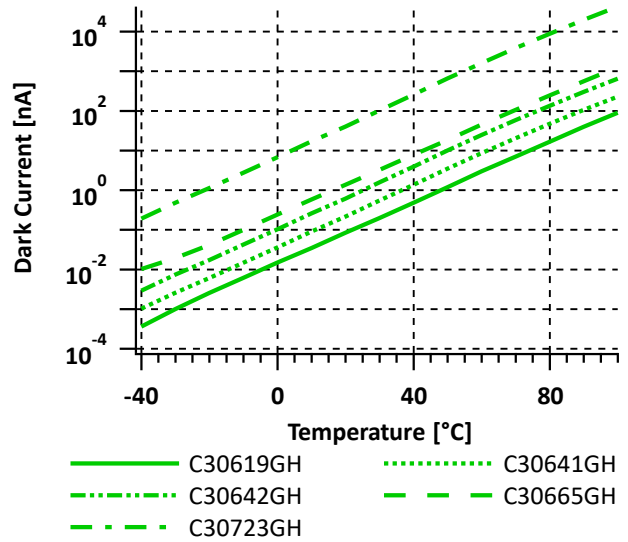
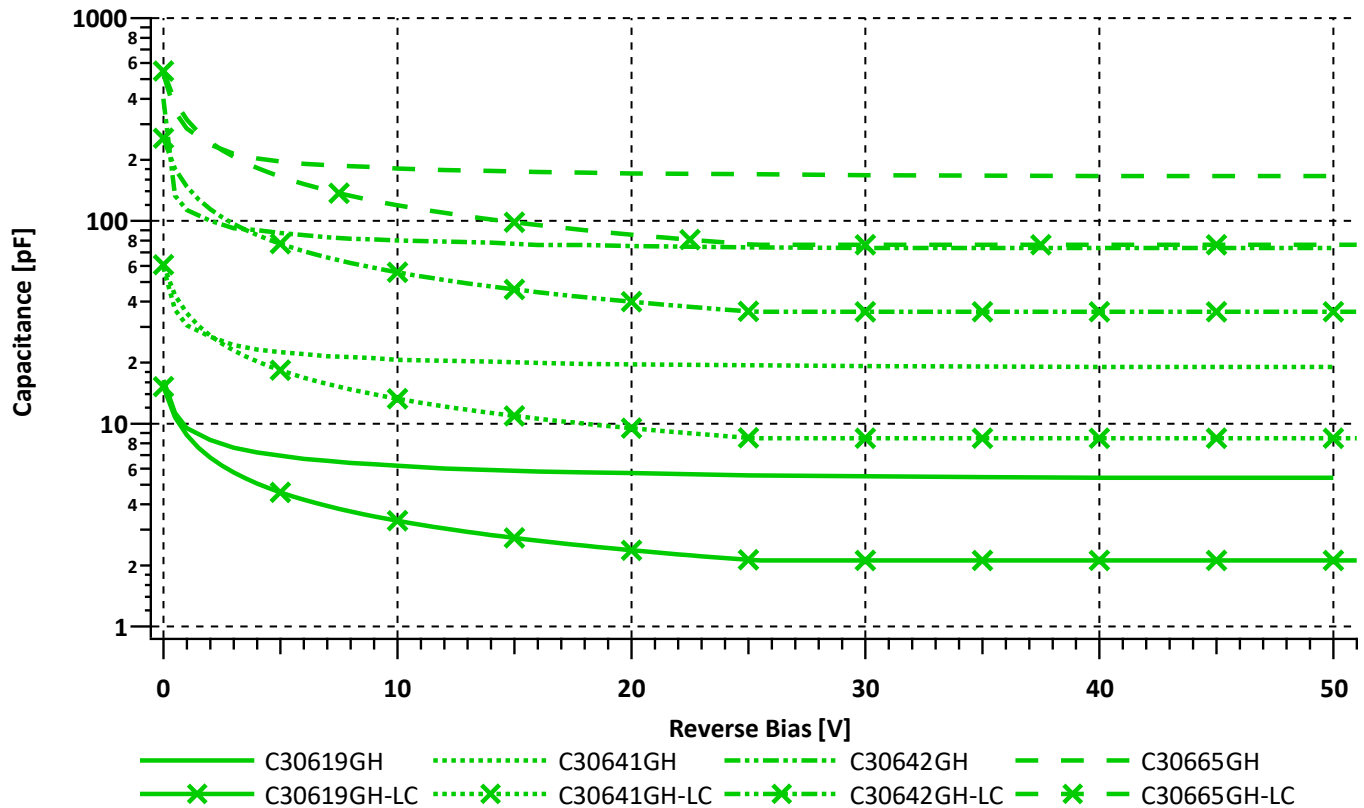

Figure 9: Typical Capacitance vs. Bias Voltage



C30619, C30641, C30642, C30665 and C30723 Series

Large Area InGaAs PIN Photodiodes

Information

Excelitas Technologies' Large Area PIN Photodiodes type C30619GH, C30641GH, C30642GH, C30665GH and C30723GH are high responsive, low capacitance InGaAs detectors. They are specially designed for measurement applications as optical power meters, fiber optic test equipment, near IR-spectroscopy and instrumentation.

Their planar passivated structure feature low capacitance for extended bandwidth and a high shunt resistance for maximum sensitivity. Typical devices feature well than 1% non-linearity to optical powers of greater than +13dBm (20 mW) and uniformity within 2% across the detector active area. Typical responsivity of 0.2 A/W at 850 nm for our large area InGaAs devices allows use of a single detector in fiber optic test instrumentation designed to operate at 850 nm, 1300 nm and 1550 nm.

Optional ultra-low capacitance devices are available (-LC option). They feature only half of the standard type capacitance, therefore exhibiting twice the 3 dB bandwidth.

Devices are available with active areas from 0.5 mm to 5.0 mm in hermetic TO packages.

Recognizing that different applications have different performance requirements, Excelitas offers a wide range of customization of these photodiodes to meet your design challenges. Responsivity and noise screening, custom device testing, TEC cooled devices and incorporating band pass filters are among many of the application-specific solutions available.

Testing methods

Excelitas verifies the electro optical specifications on every device. Visual inspection during fabrication is performed as per our quality standard and failed devices are removed.

Excelitas Technologies is certified to meet ISO-9001 and the photodiode are designed to meet MIL-STD-883 and/or MIL-STD-750 specifications.

Packaging and shipping

All Large Area InGaAs PIN Diodes are shipped in ESD safe plastic trays.

Storage and handling

Excelitas highly recommends to follow the below notes:

- Keep devices in an ESD controlled environment until final assembly.
- Keep package trays closed until final assembly.
- Remove Devices from their trays by using a vacuum pick-up tool (if applicable)
- If a manual picking method is necessary, use a vacuum pick or non-metallic tweezer.
- Do not make contact to the window surface.

C30619, C30641, C30642, C30665 and C30723 Series

Large Area InGaAs PIN Photodiodes

RoHS Compliance

This series of PIN diodes are designed and built to be fully compliant with the European Union Directive on restrictions of the use of certain hazardous substances in electrical and electronic equipment.



Warranty

A standard 12-month warranty following shipment applies. Any warranty is null and void if the photodiode window has been opened.

About Excelitas Technologies

Excelitas Technologies is a global technology leader focused on delivering innovative, customized solutions to meet the lighting, detection and other high-performance technology needs of OEM customers.

Excelitas has a long and rich history of serving our OEM customer base with optoelectronic sensors and modules for more than 45 years beginning with PerkinElmer, EG&G, and RCA. The constant throughout has been our innovation and commitment to delivering the highest quality solutions to our customers worldwide.

From aerospace and defense to analytical instrumentation, clinical diagnostics, medical, industrial, and safety and security applications, Excelitas Technologies is committed to enabling our customers' success in their specialty end-markets. Excelitas Technologies has approximately 7,000 employees in North America, Europe and Asia, serving customers across the world.

Excelitas Technologies

22001 Dumberry Road
Vaudreuil-Dorion, Quebec
Canada J7V 8P7
Telephone: (+1) 450.424.3300
Toll-free: (+1) 800.775.6786
Fax: (+1) 450.424.3345

Excelitas Technologies

GmbH & Co. KG
Wenzel-Jaksch-Str. 31
D-65199 Wiesbaden
Germany
Telephone: (+49) 611 492 430
Fax: (+49) 611 492 165

Excelitas Technologies Singapore, Pte. Ltd.

8 Tractor Road
Singapore 627969
Telephone: (+65) 6775 2022 (Main number)
Telephone: (+65) 6770 4366 (Customer Service)
Fax: (+65) 6778-1752



Contact us at <http://www.excelitas.com/contact>

For a complete listing of our global offices, visit www.excelitas.com/locations

© 2023 Excelitas Technologies Corp. All rights reserved. The Excelitas logo and design are registered trademarks of Excelitas Technologies Corp. All other trademarks not owned by Excelitas Technologies or its subsidiaries that are depicted herein are the property of their respective owners. Excelitas reserves the right to change this document at any time without notice and disclaims liability for editorial, pictorial or typographical errors.