Surface Mount RF PIN Switch Diode

Technical Data

HSMP-3880

Features

- **Diodes Optimized for:
Ultra-Low Distortion
Switching**
- **Surface Mount SOT-23
Package
Tape and Reel Options
Available**
- **Low Failure in Time (FIT)
Rate¹**
- **Lead-free Option Available**

Package Lead Code Identification (Top View)

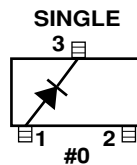

Description/Applications

The HSMP-3880 switching diode is an ultra low distortion device optimized for higher power applications to 1.5 GHz.

A SPICE model is not available for PIN diodes as SPICE does not provide for a key PIN diode characteristic, carrier lifetime.

Note:

1. For more information see the Surface Mount PIN Reliability Data Sheet.
-

Absolute Maximum Ratings^[1] $T_C = 25^\circ\text{C}$

Symbol	Parameter	Units	Absolute Maximum
I_F	Forward Current (1 ms Pulse)	Amp	1
P_t	Total Device Dissipation	mW ^[2]	250
P_{iv}	Peak Inverse Voltage	—	Same as V_{BR}
T_j	Junction Temperature	$^\circ\text{C}$	150
T_{STG}	Storage Temperature	$^\circ\text{C}$	-65 to 150

Notes:

1. Operation in excess of any one of these conditions may result in permanent damage to this device.
2. CW Power Dissipation at $T_{LEAD} = 25^\circ\text{C}$. Derate to zero at maximum rated temperature.

Typical Parameters at $T_C = 25^\circ\text{C}$

Part Number HSMP-	Series Resistance R_S (Ω)	Carrier Lifetime τ (ns)	Reverse Recovery Time T_{rr} (ns)	Total Capacitance C_T (pF)
3880	3.8	2500	550	0.30 @ 50 V
Test Conditions	$I_F = 1$ mA $f = 100$ MHz	$I_F = 50$ mA $I_R = 250$ mA	$V_R = 10$ V $I_F = 20$ mA 90% Recovery	

Electrical Specifications $T_C = 25^\circ\text{C}$

Part Number HSMP-	Package Marking Code ^[1]	Lead Code	Configuration	Minimum Breakdown Voltage V_{BR} (V)	Maximum Series Resistance R_S (Ω)	Maximum Total Capacitance C_T (pF)	Maximum Shunt Mode Harmonic Distortion Hmd (dBc)
3880	S0	0	Single	100	6.5	0.40	-55
Test Conditions				$V_R = V_{BR}$ Measure $I_R \leq 10$ μA	$I_F = 5$ mA $f = 100$ MHz	$V_R = 50$ V $f = 1$ MHz	$2f_o, Z_o = 50$ W $f_o = 400$ MHz $P_{in} = +30$ dBm 0 V bias

Note:

1. Package marking code is white.

Typical Parameters at $T_C = 25^\circ\text{C}$ (unless otherwise noted), Single Diode

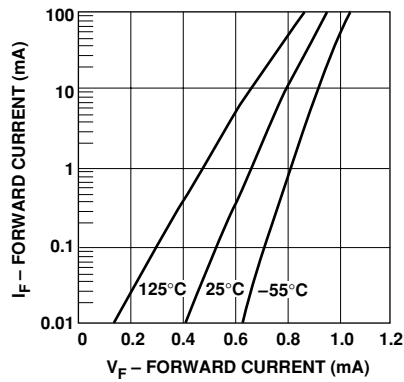

Figure 1. Forward Current vs. Forward Voltage.

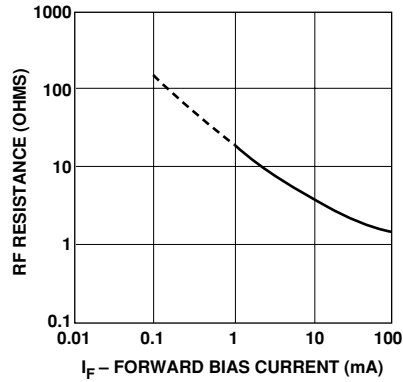

Figure 2. RF Resistance at 25°C vs. Forward Bias Current.

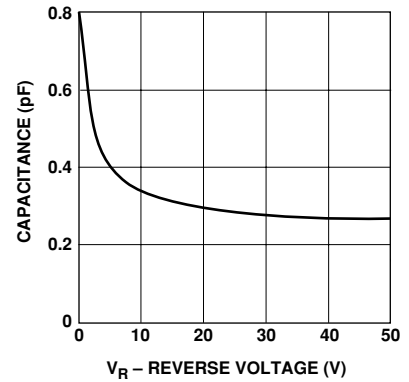

Figure 3. Capacitance vs. Reverse Voltage.

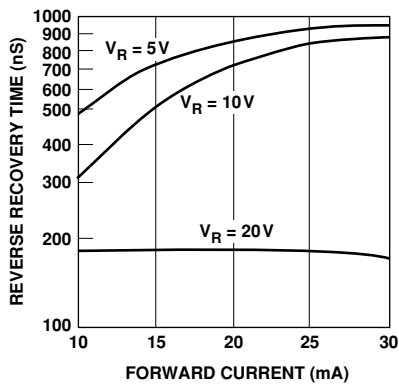

Figure 4. Typical Reverse Recovery Time vs. Reverse Voltage.

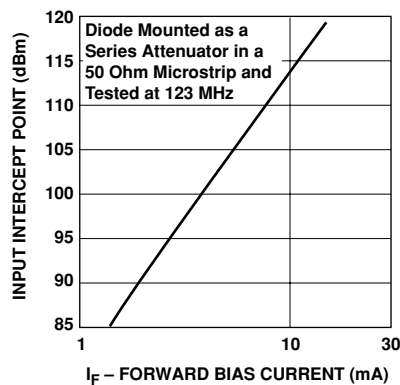
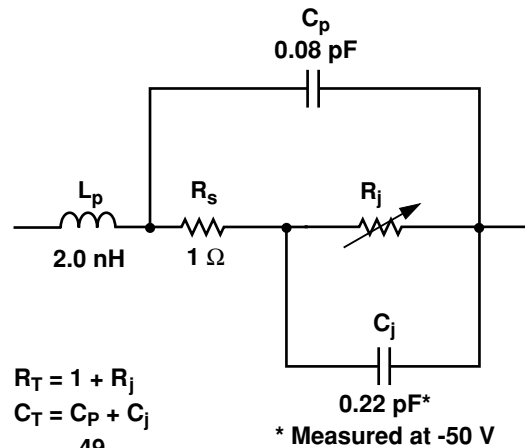

Figure 5. 2nd Harmonic Input Intercept Point vs. Forward Bias Current.

Equivalent Circuit Model HSMP-3880



$$R_T = 1 + R_j$$

$$C_T = C_p + C_j$$

$$R_j = \frac{49}{I^{0.9}} \Omega$$

I = Forward Bias Current in mA

* Measured at -50 V

Package Dimensions Outline 23 (SOT-23)

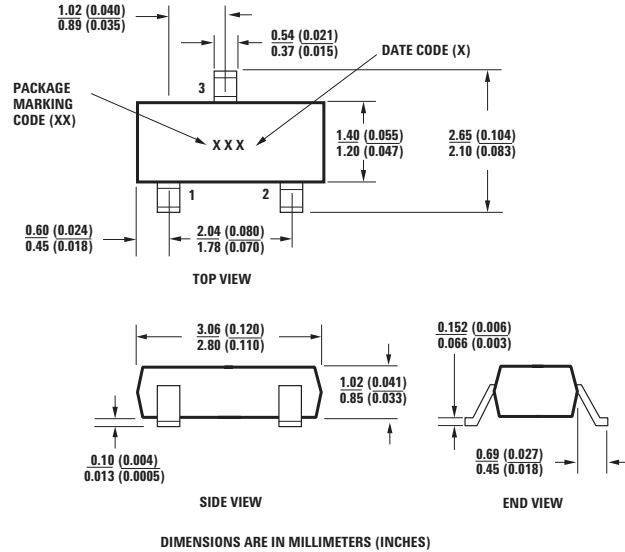

PC Board Footprints SOT-23

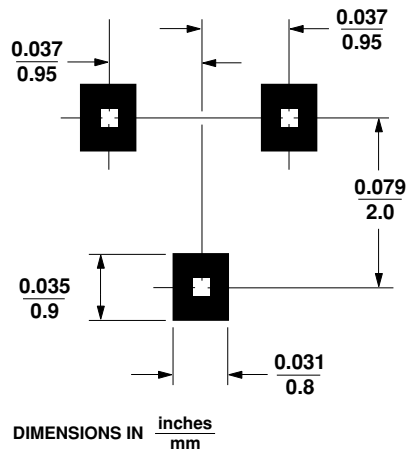

Package Characteristics

Lead Material	Alloy 42
Lead Finish	Tin-Lead 85-15%
Maximum Soldering Temperature	260°C for 5 seconds
Minimum Lead Strength	2 pounds pull
Typical Package Inductance	2 nH
Typical Package Capacitance	0.08 pF (opposite leads)

Profile Option Descriptions

-BLK = Bulk

-TR1 = 3K pc. Tape and Reel, Device Orientation; See Figure 6

-TR2 = 10K pc. Tape and Reel, Device Orientation; See Figure 6

Tape and Reeling conforms to Electronic Industries RS-481, "Taping of Surface Mounted Components for Automated Placement."

For lead-free option, the part number will have the character "G" at the end, e.g., TR2G for a 10K pc lead-free reel.

Ordering Information

Specify part number followed by option under. For example:

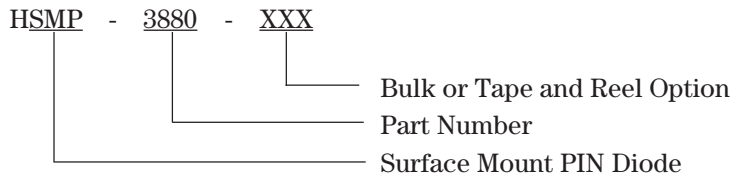

Device Orientation For Outline SOT-23

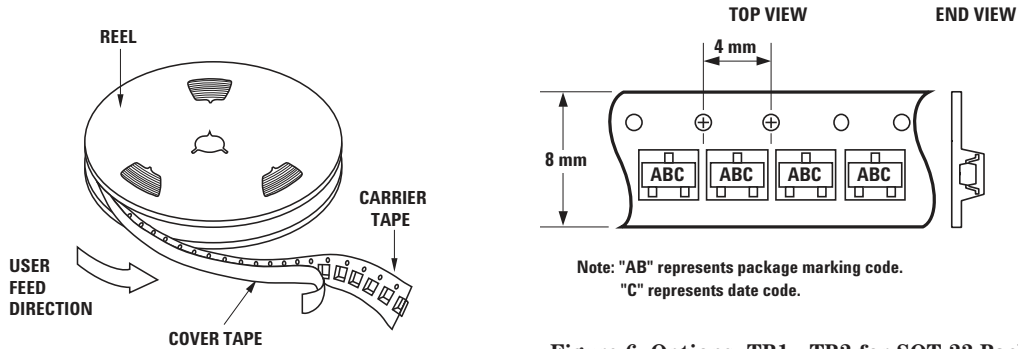
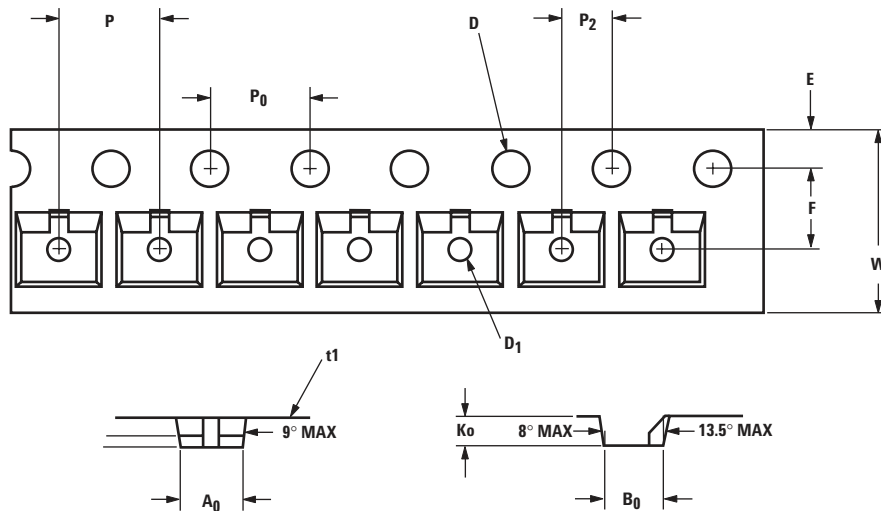

Figure 6. Options -TR1, -TR2 for SOT-23 Package.

Tape Dimensions and Product Orientation For Outline SOT-23



DESCRIPTION		SYMBOL	SIZE (mm)	SIZE (INCHES)
CAVITY	LENGTH	A ₀	3.15 ± 0.10	0.124 ± 0.004
	WIDTH	B ₀	2.77 ± 0.10	0.109 ± 0.004
	DEPTH	K ₀	1.22 ± 0.10	0.048 ± 0.004
	PITCH	P	4.00 ± 0.10	0.157 ± 0.004
	BOTTOM HOLE DIAMETER	D ₁	1.00 + 0.05	0.039 ± 0.002
PERFORATION	DIAMETER	D	1.50 + 0.10	0.059 + 0.004
	PITCH	P ₀	4.00 ± 0.10	0.157 ± 0.004
	POSITION	E	1.75 ± 0.10	0.069 ± 0.004
CARRIER TAPE	WIDTH	W	8.00 + 0.30 - 0.10	0.315 + 0.012 - 0.004
	THICKNESS	t ₁	0.229 ± 0.013	0.009 ± 0.0005
DISTANCE BETWEEN CENTERLINE	CAVITY TO PERFORATION (WIDTH DIRECTION)	F	3.50 ± 0.05	0.138 ± 0.002
	CAVITY TO PERFORATION (LENGTH DIRECTION)	P ₂	2.00 ± 0.05	0.079 ± 0.002

www.agilent.com/semiconductors

For product information and a complete list of distributors, please go to our web site.

For technical assistance call:

Americas/Canada: +1 (800) 235-0312 or (916) 788-6763

Europe: +49 (0) 6441 92460

China: 10800 650 0017

Hong Kong: (65) 6756 2394

India, Australia, New Zealand: (65) 6755 1939

Japan: (+81 3) 3335-8152(Domestic/International), or 0120-61-1280(Domestic Only)

Korea: (65) 6755 1989

Singapore, Malaysia, Vietnam, Thailand, Philippines, Indonesia: (65) 6755 2044

Taiwan: (65) 6755 1843

Data subject to change.

Copyright © 2004 Agilent Technologies, Inc.

Obsoletes 5968-7702E

March 24, 2004

5988-9924EN