



**ANATECH ELECTRONICS INC**  
RF & Microwave Filters & Products

**1525 -1575.5 / 1626 -1660.5 MHz  
Ceramic Duplexer  
Part Number: AM1550-1643D1122**



<u>Characteristics</u>	<u>Band 1</u>	<u>Band 2</u>
Passband:	1525-1575.5 MHz	1626-1660.5 MHz
Bandwidth:	50.5 MHz	34.5 MHz
Passband Return Loss:	15 dB	15 dB
Passband Insertion Loss:	1.4 dB	1.5 dB
Passband Ripple:	0.4 dB	0.5 dB min
Input / Output Impedance:	50 Ohms	50 Ohms
Isolation:	64 dB	64 dB
Power Handling:	5 W max	5 W max

<u>Mechanical</u>	
Mounting Method:	SMT
Dimensions:	40.2 x 8.5 x 6.4 mm

<u>Environmental</u>	
Operating Temperature:	-40 to +70 deg.C
Storage Temperature:	-50 to +90 deg.C

**This product is RoHs compliant.**

**Outline Drawing:**

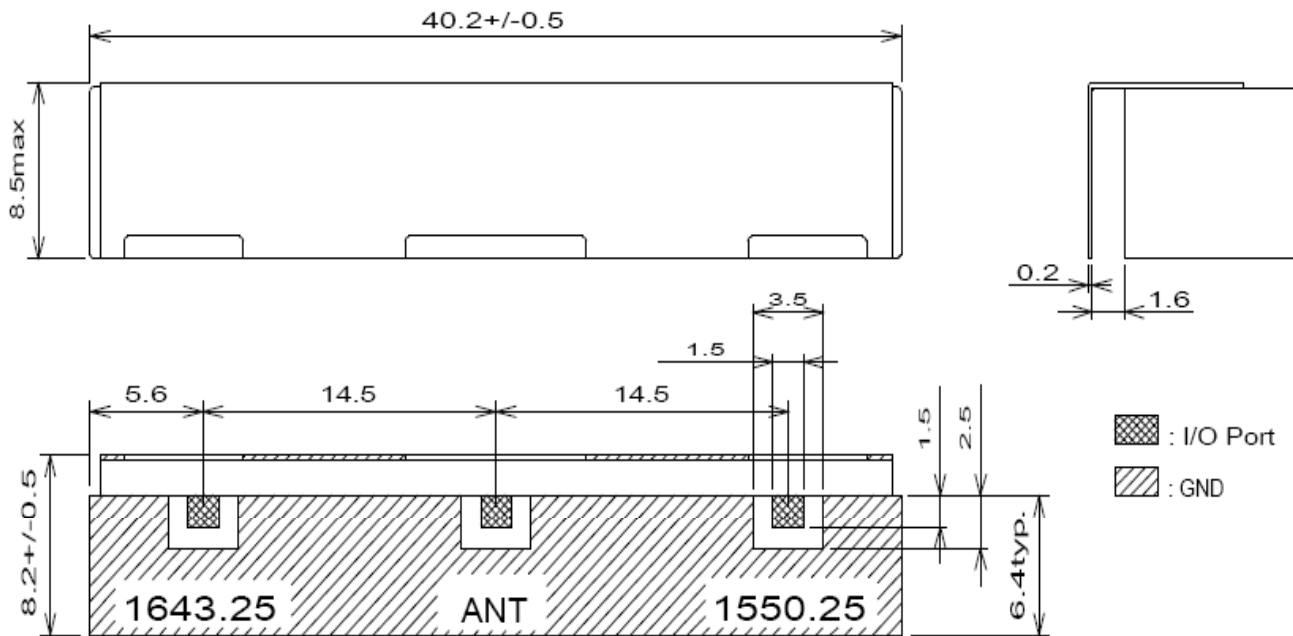

Bottom view

units:mm  
Tolerance:±0.25mm