

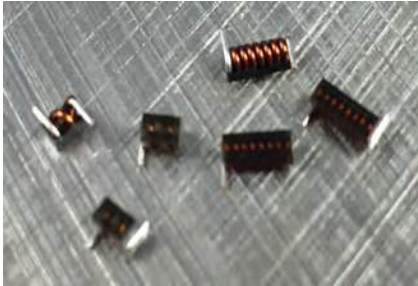

Surface Mount Air Core Inductors SMAC10 & 15

Dimensions: $\frac{\text{Inches}}{\text{(mm)}}$



Features

- Small low profile air core design
- Excellent for high Q applications
- High SRF's for high frequency applications
- Available in tight tolerances
- Flat top cap for pick and place assembly

Electrical

Impedance range: 1.65nH to 12.55nH

Tolerance: 1.65nH 10% only, 2.55nH available in 5%, 3.85nH to 12.55nH available in 2%

Test Frequency: 800MHz

Operating Temp: -40°C to +125°C

Test Equipment

(L/Q): HP4291B with HP16193

(SRF): HP8753E or HP8720D

Physical

Packaging: 1000 pieces per 7" reel

2000 pieces per 7" reel for SMAC15-10()-RC only

Marking: None

SMAC10

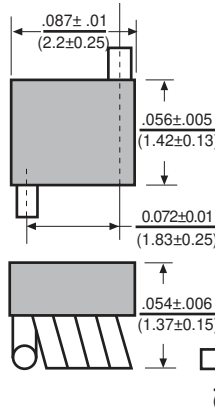

SMAC15

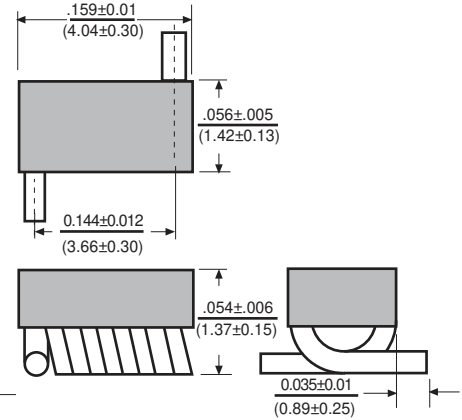

Nominal Footprint

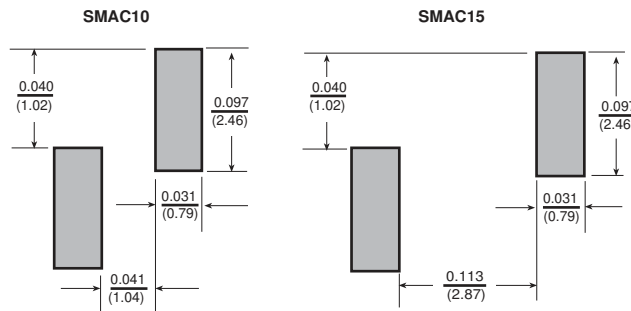

Tinned Length

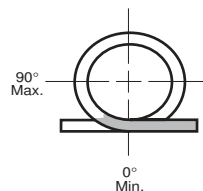

Allied Part Number	Turns	Inductance (nH)	Q Min.	Test Freq. (MHz)	SRF Min. (GHz)	DCR Max. (mΩ)	IDC A (Max.)
SMAC10-2()-RC	2	1.65	100	800	10.2	4.0	1.6
SMAC10-3()-RC	3	2.55	100	800	8.2	5.0	1.6
SMAC10-4()-RC	4	3.85	100	800	7.5	6.0	1.6
SMAC10-5()-RC	5	5.45	100	800	7.0	8.0	1.6
SMAC15-6()-RC	6	5.60	100	800	6.5	9.0	1.6
SMAC15-7()-RC	7	7.15	100	800	6.0	10.0	1.6
SMAC15-8()-RC	8	8.80	100	800	6.0	12.0	1.6
SMAC15-9()-RC	9	9.85	100	800	5.2	13.0	1.6
SMAC15-10()-RC	10	12.55	100	800	4.6	14.0	1.6

To complete part number insert tolerance designator: G = ±2%, J = ±5%, K = ±10%

All specifications subject to change without notice.