

MAX22503E

100Mbps Full-Duplex 3V/5V RS-485/RS-422 Transceiver with High EFT Immunity

General Description

The MAX22503E full-duplex, ESD-protected, RS-485/RS-422 transceiver for high-speed communication operates up to 100Mbps. This transceiver features larger receiver hysteresis for high noise rejection and improved signal integrity. Integrated hot-swap protection and a fail-safe receiver ensure a logic-high on the receiver output when input signals are shorted or open for longer than 10 μ s (typ).

The MAX22503E is available in 14-pin SOIC package and operates over the -40°C to +125°C ambient temperature range.

Applications

- Motion Control
- Encoder Interfaces
- Field Bus Networks
- Industrial Control Systems
- Backplane Busses

Benefits and Features

- High-Speed Operation
 - Up to 100Mbps Data Rate
 - High Receiver Sensitivity
 - Wide Receiver Bandwidth
 - Symmetrical Receiver Thresholds
- Integrated Protection Increases Robustness
 - -15V to +15V Common Mode Range
 - \pm 15kV ESD Protection (Human Body Model)
 - \pm 7kV IEC61000-4-2 Air-Gap ESD Protection
 - \pm 6kV IEC61000-4-2 Contact Discharge ESD Protection
 - Short-Circuit Protected Driver Outputs
- Flexibility for Many Different Applications
 - 3V to 5.5V Supply Range
 - Low 5 μ A (max) Shutdown Current
 - Available in 14-Pin SOIC Package
 - -40°C to +125°C Operating Temperature Range

[Ordering Information](#) appears at end of data sheet.

Simplified Block Diagram

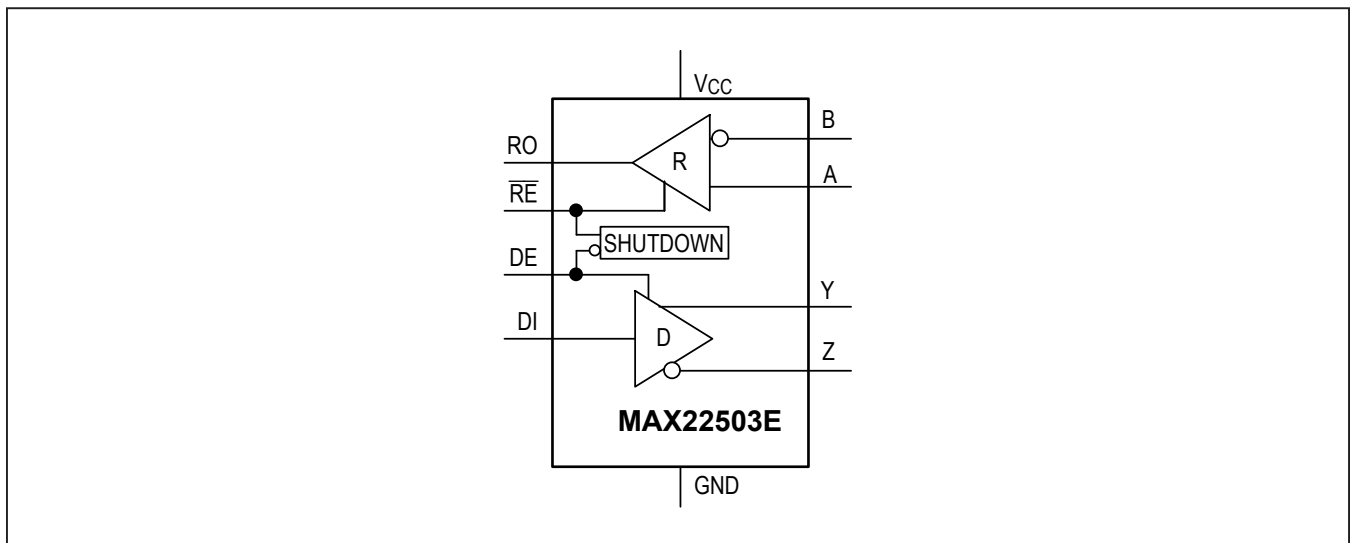

Absolute Maximum Ratings

V _{CC}	-0.3 V to +6 V	Continuous Power Dissipation (14-Pin SOIC, Multilayer Board, T _A = +70°C, derate 11.9mW/°C above +70°C).....	952.4mW
\overline{RE} , DE, DI.....	-0.3 V to +6 V	Operating Temperature Range.....	-40°C to +125°C
RO	-0.3 V to (V _{CC} + 0.3) V	Junction Temperature.....	+150°C
A, B, Y, Z	-15V to +15V	Storage Temperature Range.....	-65°C to +150°C
Short-Circuit Duration (RO, Y, Z) to GND	Continuous	Reflow Temperature	+300°C
Continuous Power Dissipation (14-Pin SOIC, Single Layer Board, T _A = +70°C, derate 8.3mW/°C above +70°C)	666.7mW		

Stresses beyond those listed under "Absolute Maximum Ratings" may cause permanent damage to the device. These are stress ratings only, and functional operation of the device at these or any other conditions beyond those indicated in the operational sections of the specifications is not implied. Exposure to absolute maximum rating conditions for extended periods may affect device reliability.

Package Information

PACKAGE TYPE: 14 SOIC	
Package Code	S14-1
Outline Number	21-0041
Land Pattern Number	90-0112
SINGLE-LAYER BOARD	
Junction to Ambient (θ _{JA})	120°C/W
Junction to Case (θ _{JC})	37°C/W
FOUR-LAYER BOARD	
Junction to Ambient (θ _{JA})	84°C/W
Junction to Case (θ _{JC})	34°C/W

For the latest package outline information and land patterns (footprints), go to www.maximintegrated.com/packages. Note that a "+", "#", or "-" in the package code indicates RoHS status only. Package drawings may show a different suffix character, but the drawing pertains to the package regardless of RoHS status.

Package thermal resistances were obtained using the method described in JEDEC specification JESD51-7, using a four-layer board. For detailed information on package thermal considerations, refer to www.maximintegrated.com/thermal-tutorial.

Electrical Characteristics

($V_{CC} = 3V$ to $5.5V$, $T_A = T_{MIN}$ to T_{MAX} , unless otherwise noted) (Notes 1, 2)

PARAMETER	SYMBOL	CONDITIONS		MIN	TYP	MAX	UNITS
POWER							
Supply Voltage	V_{CC}			3.0		5.5	V
Supply Current	I_{CC}	DE = high, \overline{RE} = low, no load			12.7	16.5	mA
Shutdown Supply Current	I_{SHDN}	DE = low, \overline{RE} = high				5	μ A
DRIVER							
Differential Driver Output	V_{OD}	Figure 1	$R_L = 54\Omega$	1.5			V
			$R_L = 100\Omega$	2.0			
Change in Magnitude of Differential Output Voltage	ΔV_{OD}	$R_L = 54\Omega$, Figure 1 (Note 3)				0.2	V
Driver Common-Mode Output Voltage	V_{OC}	$R_L = 54\Omega$, Figure 1		$V_{CC}/2$		3	V
Change In Magnitude of Common-Mode Voltage	ΔV_{OC}	$R_L = 100\Omega$ or 54Ω , Figure 1 (Note 3)				0.2	V
Single-Ended Driver Output High	V_{OH}	Y or Z output	$I_{OUT} = -20mA$	2.2			V
Single-Ended Driver Output Low	V_{OL}	Y or Z output	$I_{OUT} = +20mA$			0.8	V
Differential Output Capacitance	C_{OD}	DE = \overline{RE} = high, $f = 4MHz$		50			pF
Driver Short-Circuit Output Current	$ I_{OST} $	$-15V \leq V_{OUT} \leq +15V$				250	mA
RECEIVER							
Input Current (A and B)	$I_{A,B}$	DE = GND, $V_{CC} =$ GND, +3.6V or 5.5V	$V_{IN} = +12V$	+1100			μ A
			$V_{IN} = -7V$	-1000			
Differential Input Capacitance	$C_{A,B}$	Between A and B, DE = GND, $f = 2MHz$		50			pF
Common Mode Voltage Range	V_{CM}			-15		+15	V
Receiver Differential Threshold High	V_{TH_H}	$-15V \leq V_{CM} \leq +15V$		+50		+200	mV
Receiver Differential Threshold Low	V_{TH_L}	$-15V \leq V_{CM} \leq +15V$		-200		-50	mV
Receiver Input Hysteresis	ΔV_{TH}	$V_{CM} = 0V$, time from last transition is < t_{D_FS}		250			mV
Differential Input Fail-Safe Level	V_{TH_FS}	$-15V \leq V_{CM} \leq +15V$		-50		+50	mV

Electrical Characteristics (continued)(V_{CC} = 3V to 5.5V, T_A = T_{MIN} to T_{MAX}, unless otherwise noted) (Notes 1, 2)

PARAMETER	SYMBOL	CONDITIONS	MIN	TYP	MAX	UNITS
LOGIC INTERFACE (\overline{RE}, RO, DE, DI)						
Input Voltage High	V _{IH}	DE, DI, \overline{RE}	2/3 x V _{CC}			V
Input Voltage Low	V _{IL}	DE, DI, \overline{RE}		1/3 x V _{CC}		V
Input Current	I _{IN}	DI and DE, \overline{RE} (after first transition)	-2		+2	μA
Input Impedance on First Transition	R _{IN_FT}	DE, \overline{RE}			10	kΩ
RO Output Voltage High	V _{OH}	\overline{RE} = GND, (V _A - V _B) > 200mV, I _{OUT} = -1mA	V _{CC} - 0.4			V
RO Output Low Voltage	V _{OL}	\overline{RE} = GND, (V _A - V _B) < -200mV, I _{OUT} = +1mA			0.4	V
Three-State Output Current at Receiver	I _{OZR}	\overline{RE} = high, 0 ≤ V _{RO} ≤ V _{CC}	-1		+1	μA
PROTECTION						
Thermal Shutdown Threshold	T _{SH}	Die temperature rising		+160		°C
Thermal Shutdown Hysteresis	T _{SH_HYS}			10		°C
ESD Protection (A and B Pins)		Human Body Model		±15		kV
		IEC61000-4-2 Air Gap Discharge to GND		±7		
		IEC61000-4-2 Contact Discharge to GND		±6		
ESD Protection (All Other Pins)		Human Body Model		±2		kV

Electrical Characteristics - Switching(V_{CC} = 3V to 5.5V, T_A = T_{MIN} to T_{MAX}, unless otherwise noted) (Notes 1, 2)

PARAMETER	SYMBOL	CONDITIONS	MIN	TYP	MAX	UNITS
DRIVER (Note 4)						
Driver Propagation Delay	t _{DPLH}	R _L = 54Ω, C _L = 50pF, Figure 2 , Figure 3			20	ns
	t _{DPHL}	R _L = 54Ω, C _L = 50pF, Figure 2 , Figure 3			20	
Differential Driver Output Skew	t _{DSKEW}	t _{DPLH} - t _{DPHL} , R _L = 54Ω, C _L = 50pF, Figure 2 , Figure 3 (Note 5)			1.2	ns
Driver Differential Output Rise and Fall Time	t _{HL} , t _{LH}	R _L = 54Ω, C _L = 50pF, Figure 3 (Note 5)			3	ns
Data Rate	DR				100	Mbps
Driver Enable to Output High	t _{DZH}	R _L = 500Ω, C _L = 50pF, Figure 4 , Figure 5			30	ns
Driver Enable to Output Low	t _{DZL}	R _L = 500Ω, C _L = 50pF, Figure 4 , Figure 5			30	ns
Driver Disable Time from Low	t _{DLZ}	R _L = 500Ω, C _L = 50pF, Figure 4 , Figure 5			30	ns
Driver Disable Time from High	t _{DHZ}	R _L = 500Ω, C _L = 50pF, Figure 4 , Figure 5			30	ns
Driver Enable from Shutdown to Output High	t _{DZH(SHDN)}	R _L = 1kΩ, C _L = 15pF, Figure 4 , Figure 5			100	μs

Electrical Characteristics - Switching (continued)(V_{CC} = 3V to 5.5V, T_A = T_{MIN} to T_{MAX}, unless otherwise noted) (Notes 1, 2)

PARAMETER	SYMBOL	CONDITIONS	MIN	TYP	MAX	UNITS
Driver Enable from Shutdown to Output Low	t _{DZL(SHDN)}	R _L = 1kΩ, C _L = 15pF, Figure 4 , Figure 5			100	μs
Time to Shutdown	t _{SHDN}	(Note 6, Note 7)	50		800	ns
RECEIVER (Note 4)						
Delay to Fail-Safe Operation	t _{D_FS}			10		μs
Receiver Propagation Delay	t _{RPLH}	C _L = 15pF, Figure 6 , Figure 7			20	ns
	t _{RPHL}	C _L = 15pF, Figure 6 , Figure 7			20	
Receiver Output Skew	t _{RSKEW}	t _{RPHL} - t _{RPLH} , C _L = 15pF, Figure 6 , Figure 7 (Note 5)			2.5	ns
Data Rate	DR				100	Mbps
Receiver Enable to Output High	t _{RZH}	R _L = 1kΩ, C _L = 15pF, Figure 8			30	ns
Receiver Enable to Output Low	t _{RZL}	R _L = 1kΩ, C _L = 15pF, Figure 8			30	ns
Receiver Disable Time from Low	t _{RLZ}	R _L = 1kΩ, C _L = 15pF, Figure 8			30	ns
Receiver Disable Time from High	t _{RHZ}	R _L = 1kΩ, C _L = 15pF, Figure 8			30	ns
Receiver Enable from Shutdown to Output High	t _{RZH(SHDN)}	R _L = 1kΩ, C _L = 15pF, Figure 8			100	μs
Receiver Enable from Shutdown to Output Low	t _{RZL(SHDN)}	R _L = 1kΩ, C _L = 15pF, Figure 8			100	μs
Time to Shutdown	t _{SHDN}	(Note 6, Note 7)	50		800	ns

Note 1: All devices are 100% production tested at T_A = +25°C. Specifications for all temperature limits are guaranteed by design.**Note 2:** All currents into the device are positive; all currents out of the device are negative. All voltages are referenced to device ground, unless otherwise noted.**Note 3:** ΔV_{OD} and ΔV_{OC} are the changes in V_{OD} and V_{OC}, respectively, when the DI input changes state.**Note 4:** Capacitive load includes test probe and fixture capacitance.**Note 5:** Not production tested. Guaranteed by design.**Note 6:** Shutdown is enabled by driving \overline{RE} high and DE low. The device is guaranteed to have entered shutdown after t_{SHDN} has elapsed.**Note 7:** The timing parameter refers to the driver or receiver enable delay, when the device has exited the initial hot-swap protect state and is in normal operating mode.

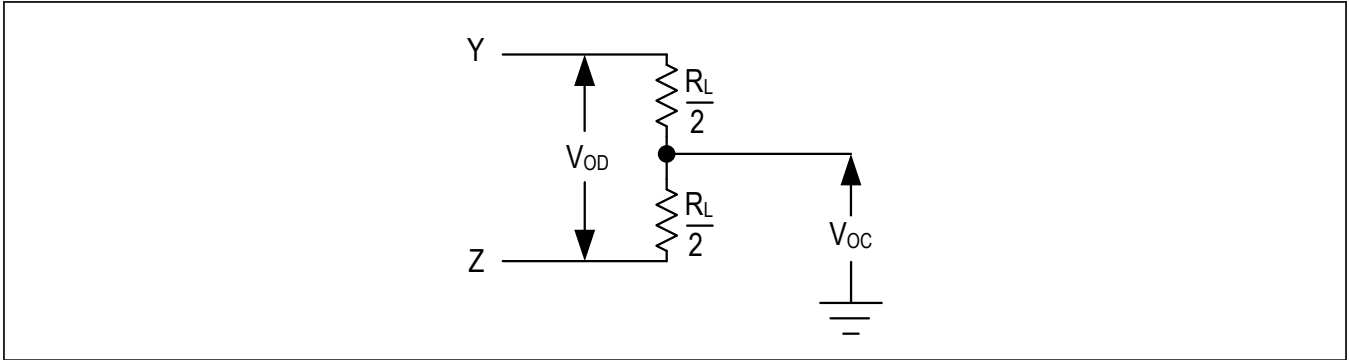

Figure 1. Driver DC Test Load

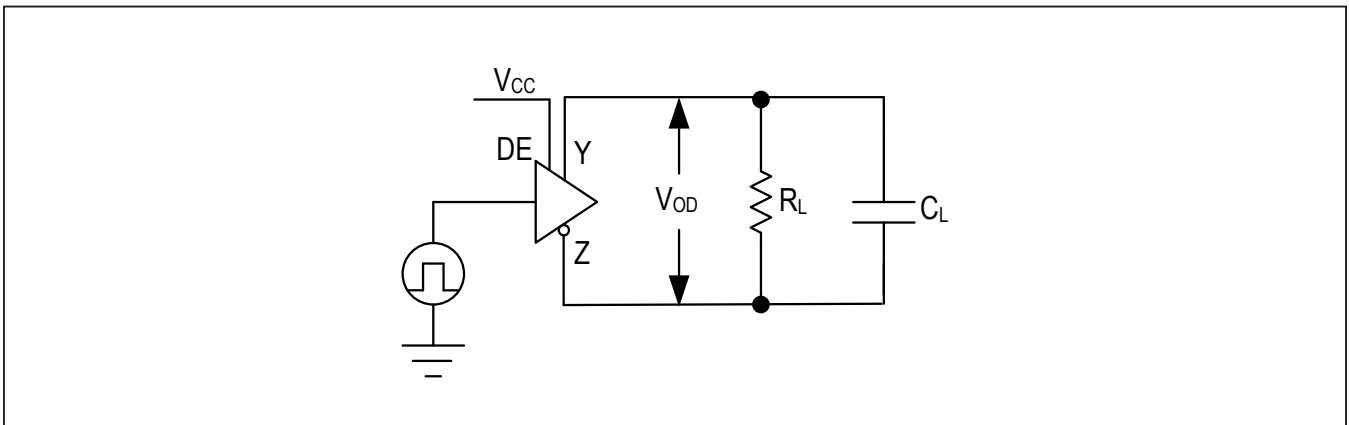

Figure 2. Driver Timing Test Circuit

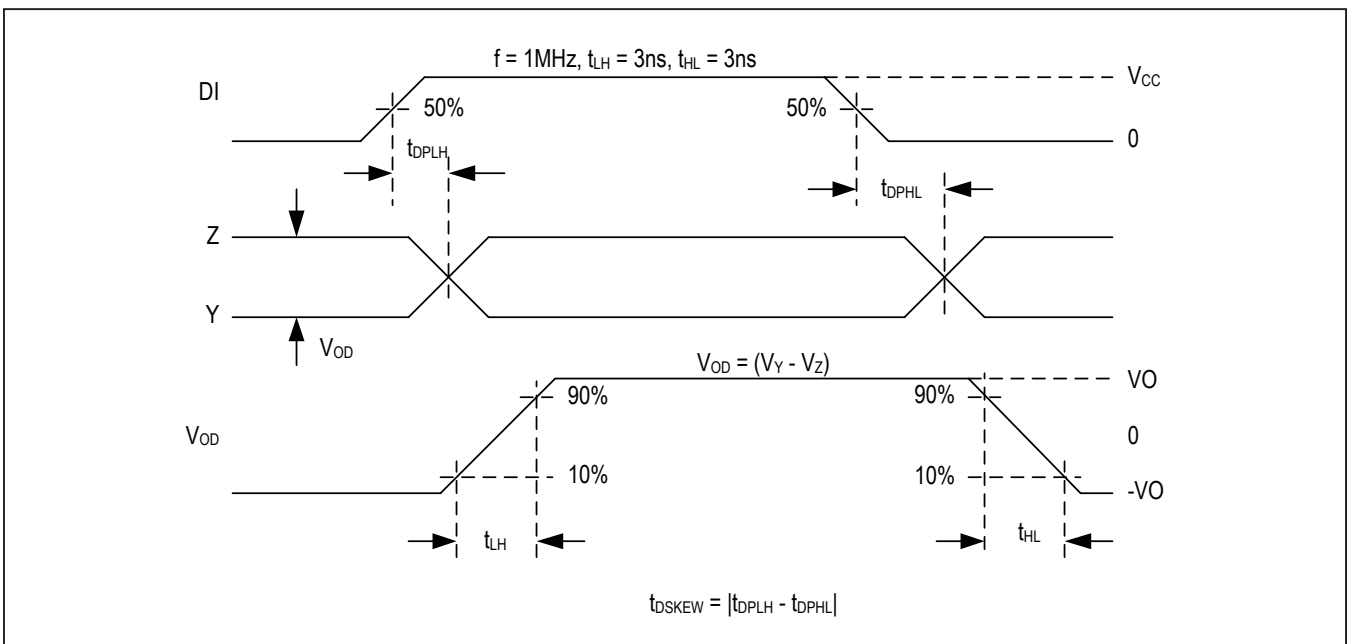

Figure 3. Driver Propagation Delays

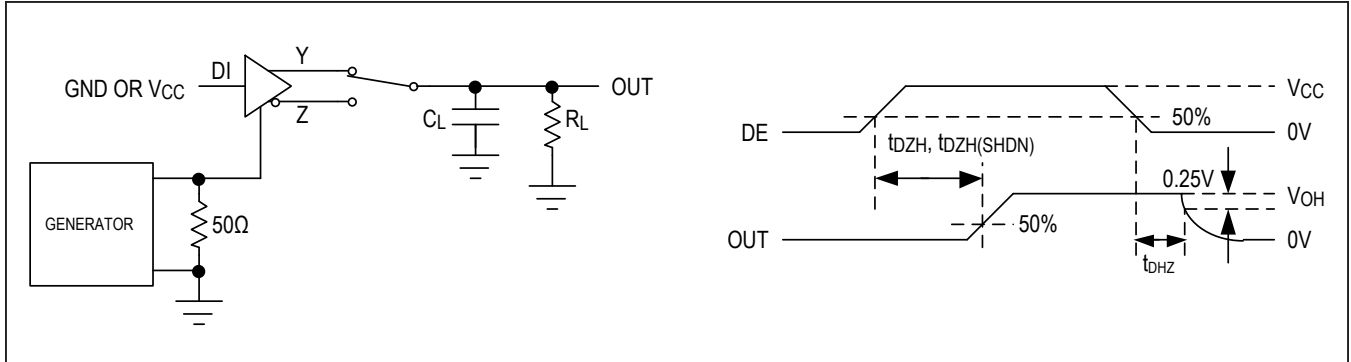

Figure 4. Driver Enable and Disable Times (t_{DZH} , t_{DHZ})

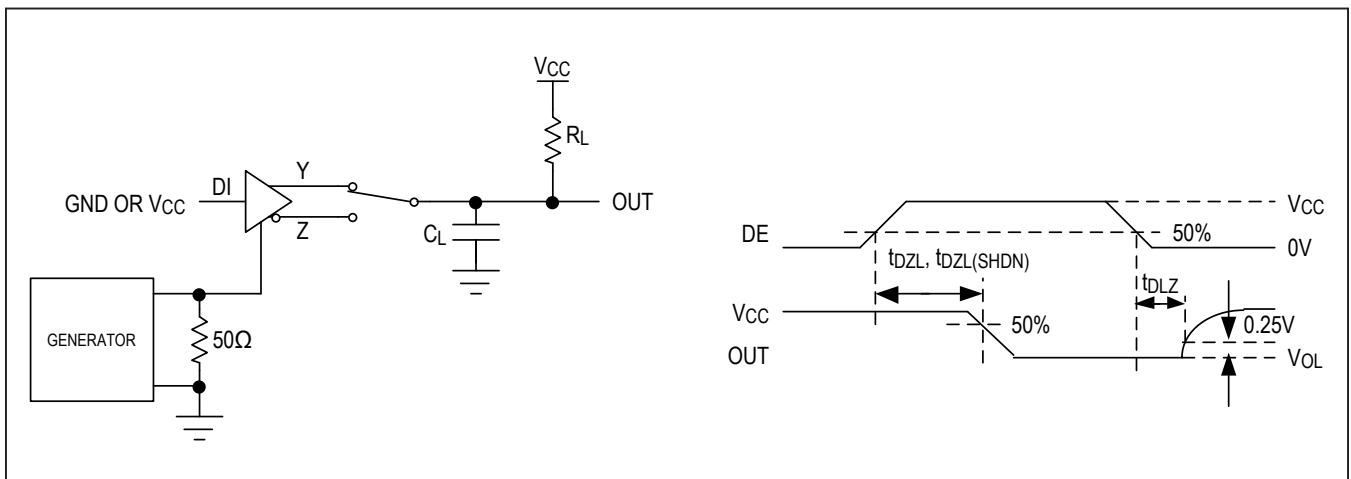

Figure 5. Driver Enable and Disable Times (t_{DZL} , t_{DLZ})

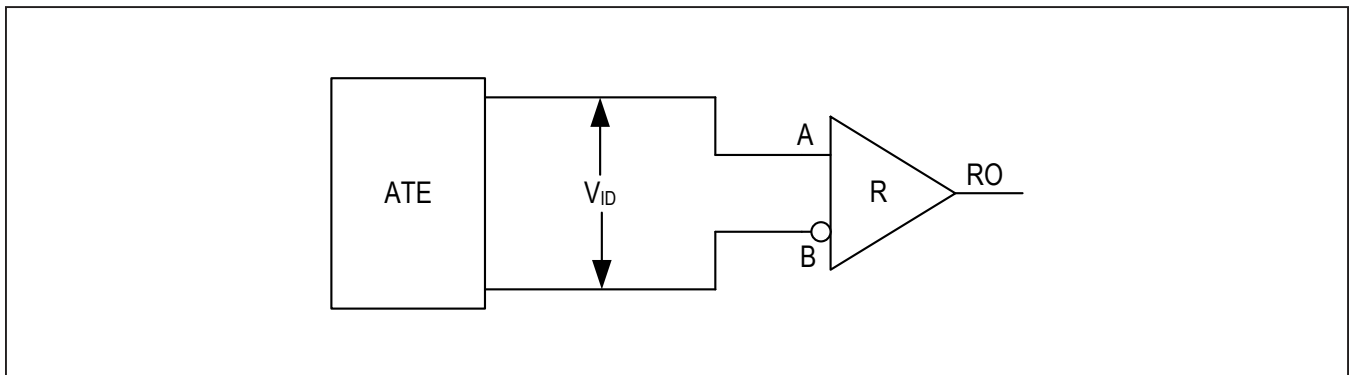

Figure 6. Receiver Propagation Delay Test Circuit

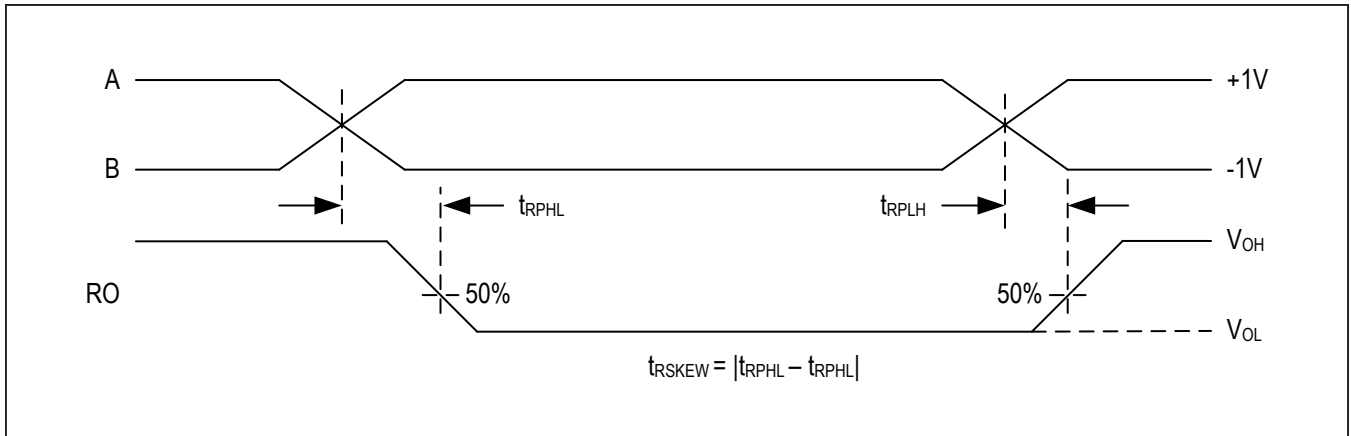

Figure 7. Receiver Propagation Delays

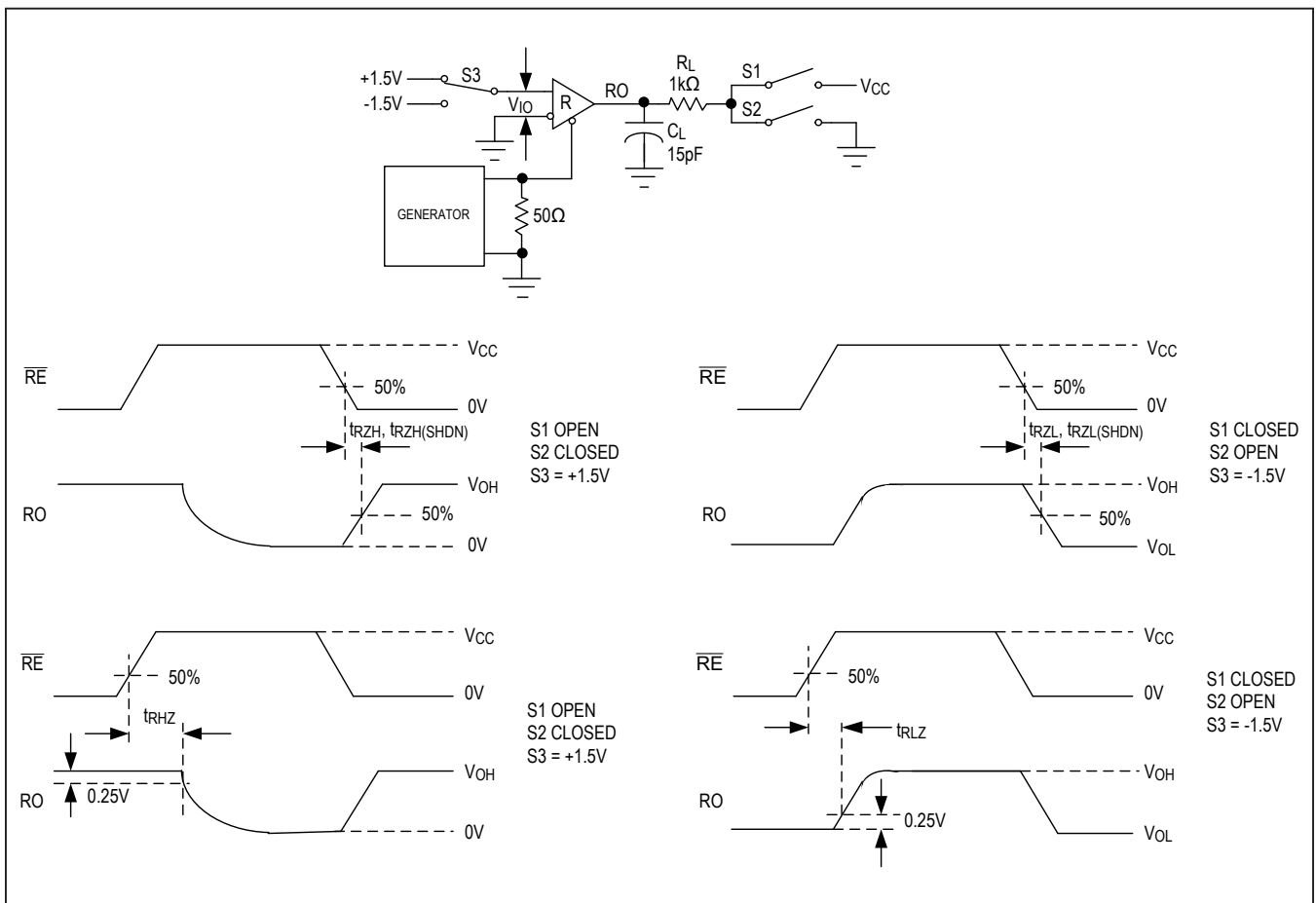
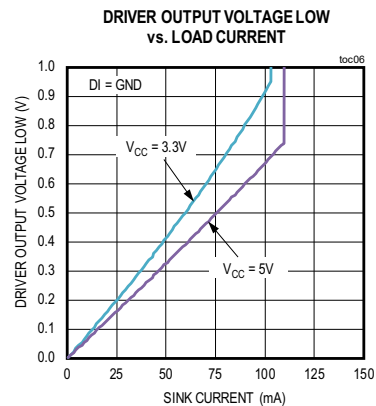
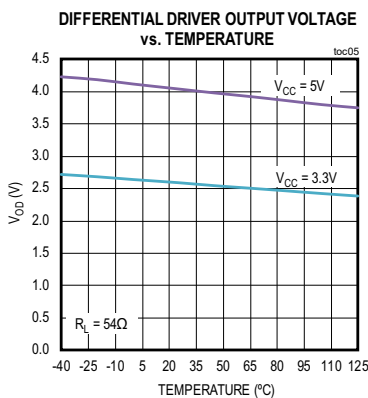
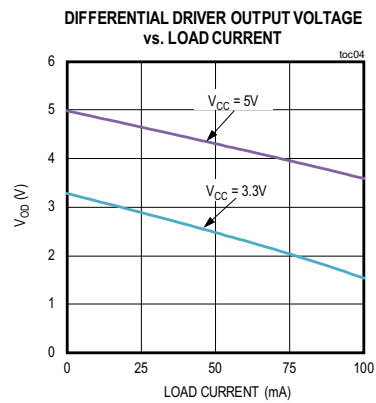
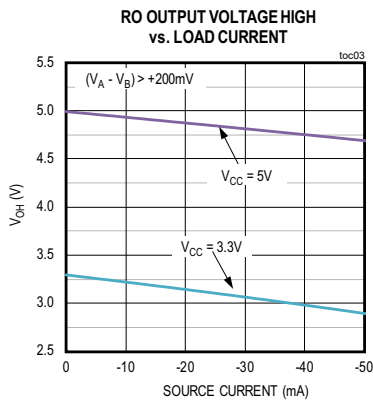
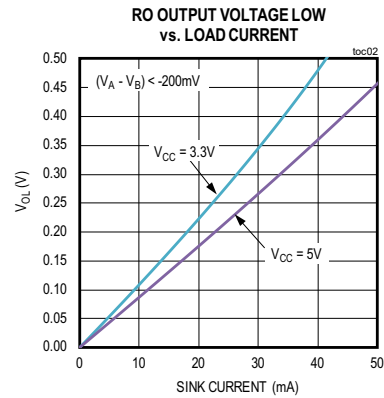
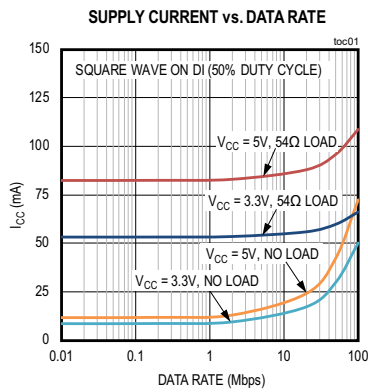

Figure 8. Receiver Enable and Disable Times

Typical Operating Characteristics

$V_{CC} = 5V$, 60Ω termination between Y and Z, $T_A = 25^\circ C$, unless otherwise noted.



Typical Operating Characteristics (continued)

$V_{CC} = 5V$, 60Ω termination between Y and Z, $T_A = 25^\circ C$, unless otherwise noted.

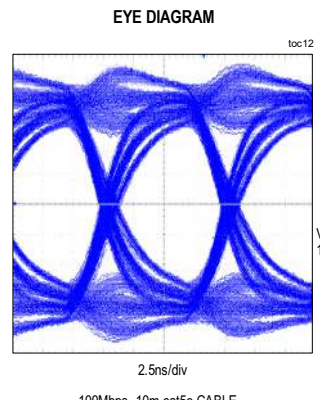
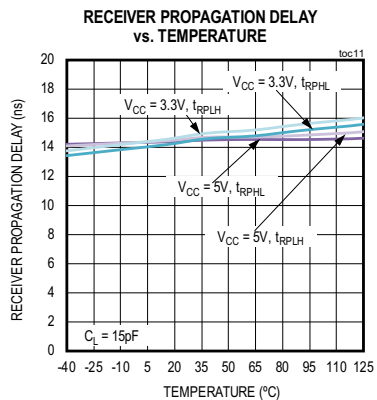
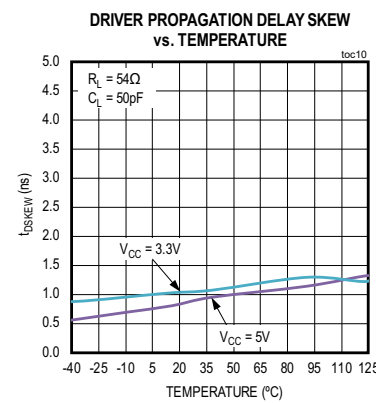
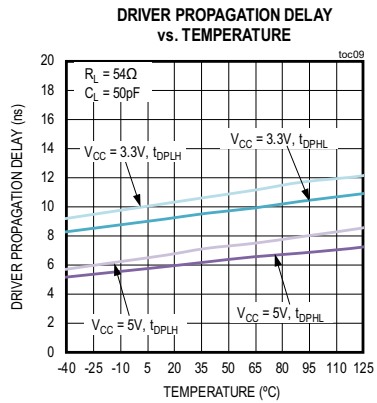
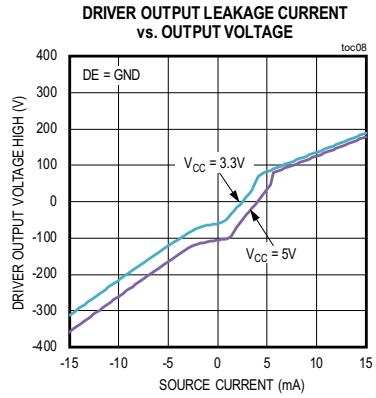
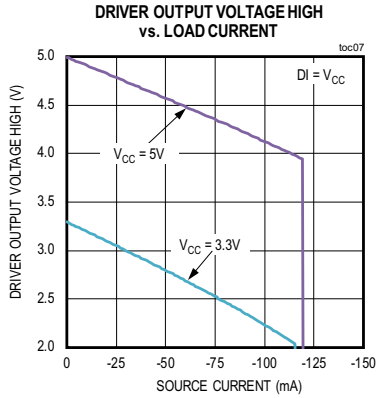

Pin Configuration

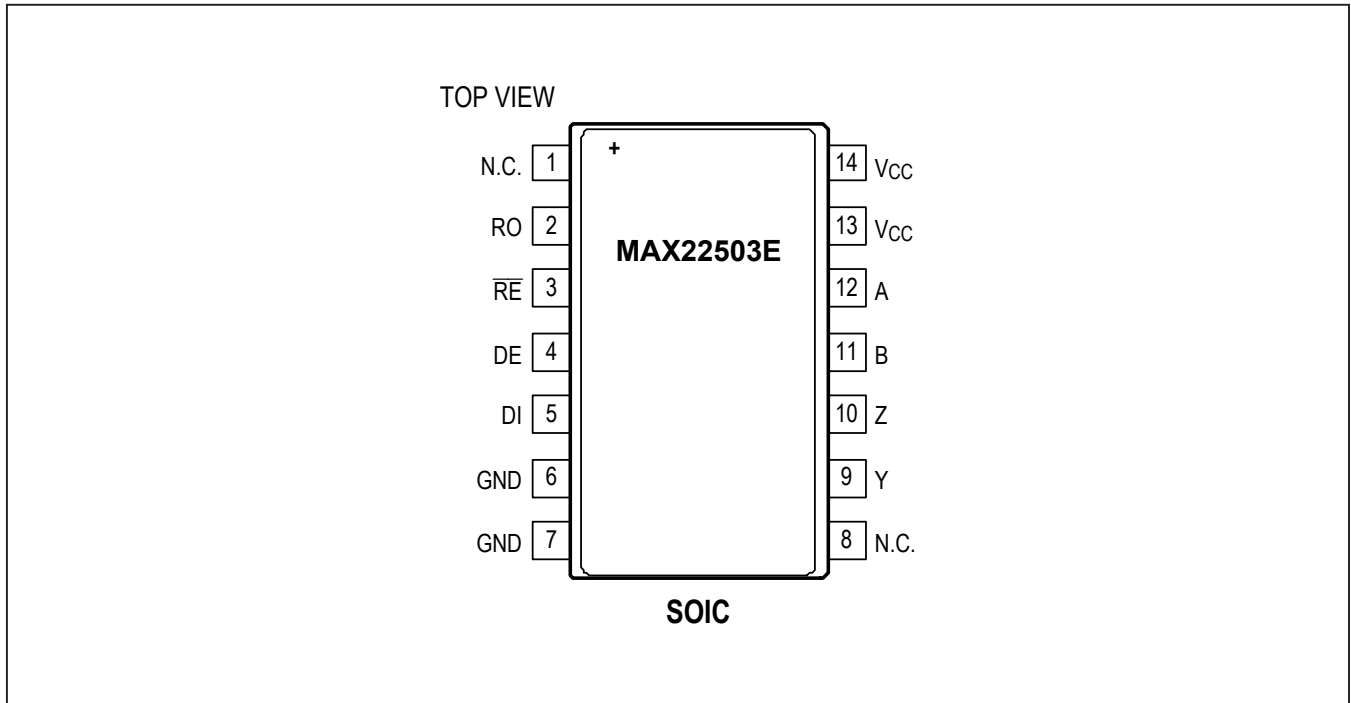

Pin Description

MAX22503E

PIN	NAME	FUNCTION
1, 8	N.C.	Not connected. Not internally connected.
2	RO	Receiver Output. See the Receiving Function Table for more information.
3	\overline{RE}	Receiver Enable. Set \overline{RE} high to disable the receiver and three-state RO. The device is in low-power shutdown when \overline{RE} = high and DE = low.
4	DE	Driver Output Enable. Set DE high to enable driver. Set DE low to set the driver output in three-state.
5	DI	Driver Input. See the Transmitting Function Table for more information.
6, 7	GND	Ground
9	Y	Noninverting Driver Output
10	Z	Inverting Driver Output
11	B	Inverting Receiver Input
12	A	Noninverting Receiver Input
13, 14	V_{CC}	Supply Input. Bypass V_{CC} to ground with a 0.1 μ F ceramic capacitor as close to the device as possible.

Functional Diagrams

Transmitting Function Table

INPUTS			OUTPUTS	
\overline{RE}	DE	DI	Y	Z
X	1	1	1	0
X	1	0	0	1
0	0	X	High Impedance	High Impedance
1	0	X	Shutdown. Y and Z are high-impedance	

X = Don't care

Receiving Function Table

INPUTS				OUTPUTS
\overline{RE}	DE	$(V_A - V_B)$	Time from Last A-B Transition	RO
0	X	$\geq V_{TH_H}$	Always	1
0	X	$V_{TH_L} < (V_A - V_B) < V_{TH_H}$	$< t_{D_FS}$	Indeterminate RO is latched to previous value
0	X	$-50mV < (V_A - V_B) < +50mV$	$> t_{D_FS}$	1
0	X	$\leq V_{TH_L}$	Always	0
0	X	Open/Shorted	$> t_{D_FS}$	1
1	1	X	X	High Impedance
1	0	X	X	Shutdown. RO is high-impedance

X = Don't care

Typical Application Circuit

Full-Duplex Point-to-Point Application Circuit

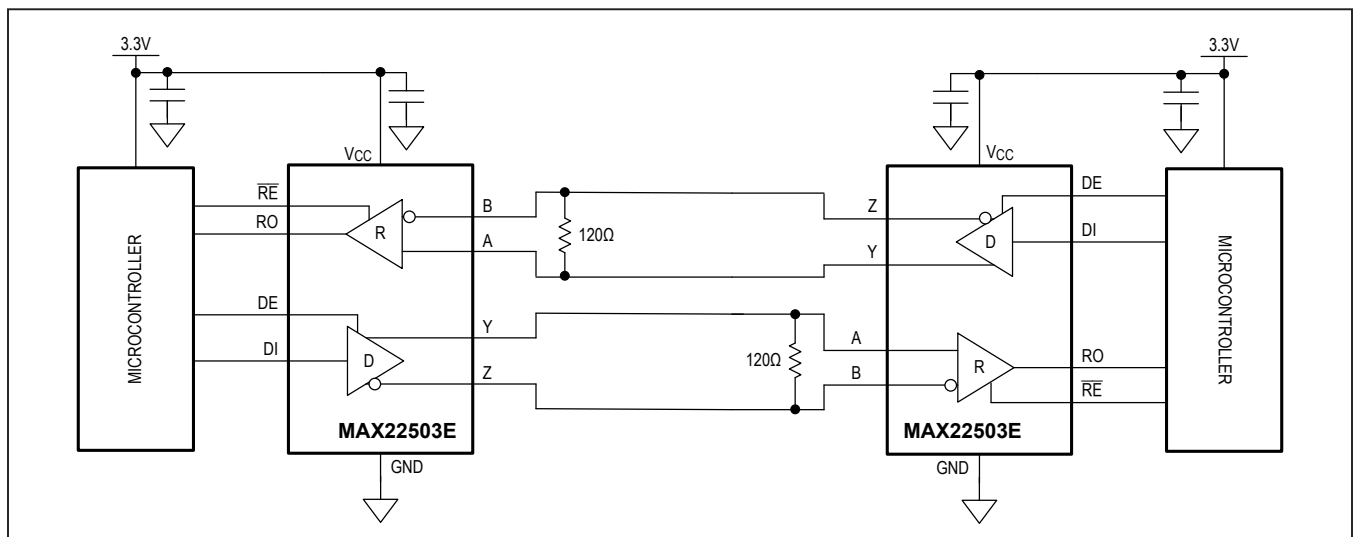

Detailed Description

The MAX22503E ESD-protected RS-485/RS-422 transceiver for high-speed, full-duplex communications operates up to 100Mbps. This transceiver features integrated hot-swap functionality to eliminate false transitions on the driver during power-up or during a hot-plug event. Fail-safe receiver inputs guarantee a logic-high on the receiver output when inputs are shorted or open for longer than 10 μ s (typ).

Receiver Threshold Voltages

The MAX22503E receiver features a large threshold hysteresis of 250mV (typ) for increased differential noise rejection.

Additionally, the receiver features symmetrical threshold voltages. Symmetric thresholds have the advantage that recovered data at the RO output does not have duty cycle distortion. Typically, fail-safe receivers, which have unipolar (non-symmetric) thresholds, show some duty cycle distortion at high signal attenuation due to long cable lengths.

Fail-Safe Functionality

The MAX22503E features fail-safe receiver inputs, guaranteeing a logic-high on the receiver output (RO) when the receiver inputs are shorted or open for longer than 10 μ s (typ). When the differential receiver input voltage is less than 50mV for more than 10 μ s (typ), RO is logic-high. For example, in the case of a terminated bus with all transmitters disabled, the receiver's differential input voltage is pulled to 0V by the termination resistor, so $(V_A - V_B = 0V) > -50mV$ and RO is guaranteed to be a logic-high after 10 μ s (typ).

Driver Single-Ended Operation

The Y and Z outputs on the MAX22503E can be used in the standard differential operating mode or as single-ended outputs. Because the driver outputs swing rail-to-rail, they can also be used as individual standard TTL logic outputs.

Hot-Swap Capability

The DE and \overline{RE} enable inputs feature hot-swap functionality. At each input there are two NMOS devices, M1 and M2 (Figure 9). When V_{CC} ramps from zero, an internal 10ms timer turns on M2 and sets the SR latch, which also turns on M1. Transistors M2, a 500 μ A current sink, and M1, a 100 μ A current sink, pull DE to GND through a 5k Ω resistor. M2 is designed to pull DE to the disabled state against an external parasitic capacitance up to 100pF that can drive DE high. After 10 μ s, the timer deactivates M2 while M1 remains on, holding DE low against three-state leakages that can drive DE high. M1 remains on until an external source overcomes the required input current. At this time, the SR latch resets and M1 turns off. When M1 turns off, DE reverts to a standard, high-impedance CMOS input. Whenever V_{CC} drops below 1V, the hot-swap input is reset.

There is a complimentary circuit for \overline{RE} that uses two PMOS devices to pull \overline{RE} to V_{CC} .

Driver Output Protection

Two mechanisms prevent excessive output current and power dissipation caused by faults or by bus contention. The first, a current limit on the output stage provides immediate protection against short circuits over the whole common-mode voltage range. The second, a thermal-shutdown circuit, forces the driver outputs into a high-impedance state if the die temperature exceeds +160 $^{\circ}$ C (typ).

Low-Power Shutdown Mode

The MAX22503E features low-power shutdown mode to reduce supply current when the transceiver is not needed. Pull the \overline{RE} input high and the DE input low to put the device in low-power shutdown mode. If the inputs are in this state for at least 800ns, the part is guaranteed to enter shutdown. The MAX22503E draws 5 μ A (max) of supply current when the device is in shutdown.

The \overline{RE} and DE inputs can be driven simultaneously. The MAX22503E is guaranteed not to enter shutdown if \overline{RE} is high and DE is low for less than 50ns.

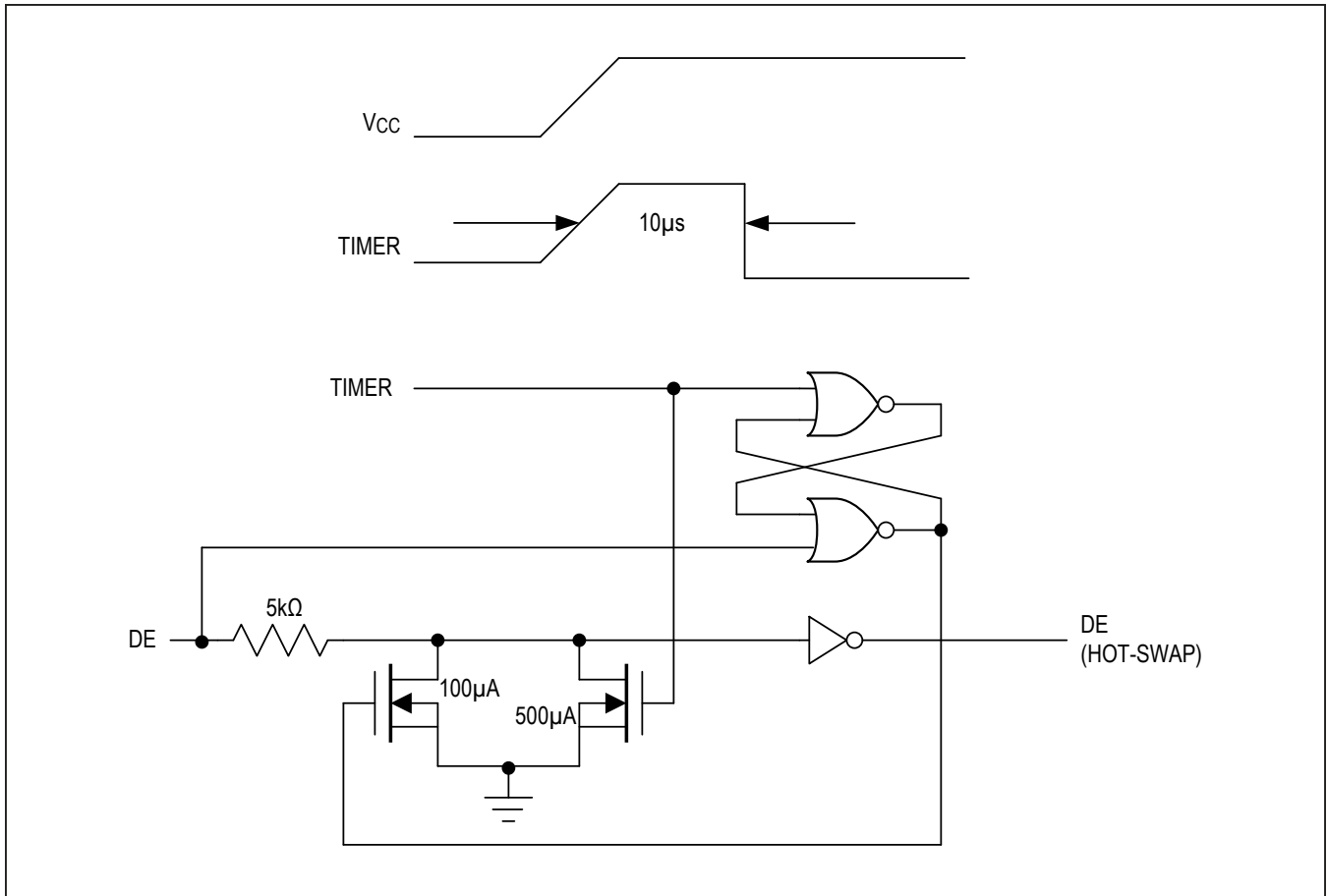

Figure 9. Simplified Structure of the Driver Enable (DE) Pin

Applications Information

Network Topology

The MAX22503E transceiver is designed for high-speed bidirectional RS-485/RS-422 data communications. Multidrop networks can cause impedance discontinuities which affect signal integrity. Maxim recommends using a point-to-point network topology, instead of a multidrop topology, when communicating with high data rates. Terminate the transmission line at both ends with the cable's characteristic impedance to reduce reflections.

Ordering Information

PART	PIN-PACKAGE	PACKAGE CODE
MAX22503EASD+	14 SOIC	S14-1
MAX22503EASD+T	14 SOIC	S14-1

+Denotes a lead (Pb)-free/RoHS-compliant package.
T = Tape and reel.

MAX22503E

100Mbps Full-Duplex 3V/5V RS-485/RS-422
Transceiver with High EFT Immunity

Revision History

REVISION NUMBER	REVISION DATE	DESCRIPTION	PAGES CHANGED
0	5/19	Initial release	—

For pricing, delivery, and ordering information, please visit Maxim Integrated's online storefront at <https://www.maximintegrated.com/en/storefront/storefront.html>.

Maxim Integrated cannot assume responsibility for use of any circuitry other than circuitry entirely embodied in a Maxim Integrated product. No circuit patent licenses are implied. Maxim Integrated reserves the right to change the circuitry and specifications without notice at any time. The parametric values (min and max limits) shown in the Electrical Characteristics table are guaranteed. Other parametric values quoted in this data sheet are provided for guidance.