

ARCNET[®] Twisted Pair and Coaxial Compatible High Impedance Transceiver HIT[™]

FEATURES

- ARCNET on Twisted Pair or Coaxial Cable
- Drives Shielded and Unshielded Twisted Pair Cable or Coaxial Cable
- Compatible with Existing ARCNET Installations
- 2.5 Mbps operation
- Supports Star, Bus, and Daisy Chained Configurations
- Enhanced Built-in Filters for Reduced EMI
- Twenty Pin Single In-Line Package
- Straight or Right Angle Lead Frame
- New Reduced Size

GENERAL DESCRIPTION

The HYC9088A Twisted Pair and Coaxial Compatible High Impedance Transceiver (HIT) is a hybrid module that interfaces an ARCNET Local Area Network controller to one twisted pair or coaxial cable. The HIT interfaces directly with Standard Microsystems Corporation's ARCNET LAN controllers operating at 2.5 Mbps and connects to a variety of shielded and unshielded twisted pair or coaxial cables via an on-board transformer. The network topologies supported by the HIT are daisy chain, star, and bus configurations.

During data transmission, the HIT converts the digital pulse information provided by the ARCNET LAN controller into analog signals and drives them onto the cable. The transmitted signals are filtered to eliminate undesirable frequencies. The receiver section of the HYC9088 identifies dipulse signals on the cable and converts them into TTL signals to be supplied to the ARCNET LAN controller.

The HIT supports ARCNET's Dipulse Encoding Scheme and, is 100% compatible with all existing coax-based ARCNET networks. This provides an ARCNET network designer with flexibility to easily combine coax and twisted pair cabling.

ORDERING INFORMATION

Order Number(s):

HYC9088A R for right angle lead frame leaded package
HYC9088A R-LF for right angle lead frame lead-free RoHS compliant package



80 ARKAY DRIVE, HAUPPAUGE, NY 11788 (631) 435-6000, FAX (631) 273-3123

Copyright © 2007 SMSC or its subsidiaries. All rights reserved.

Circuit diagrams and other information relating to SMSC products are included as a means of illustrating typical applications. Consequently, complete information sufficient for construction purposes is not necessarily given. Although the information has been checked and is believed to be accurate, no responsibility is assumed for inaccuracies. SMSC reserves the right to make changes to specifications and product descriptions at any time without notice. Contact your local SMSC sales office to obtain the latest specifications before placing your product order. The provision of this information does not convey to the purchaser of the described semiconductor devices any licenses under any patent rights or other intellectual property rights of SMSC or others. All sales are expressly conditional on your agreement to the terms and conditions of the most recently dated version of SMSC's standard Terms of Sale Agreement dated before the date of your order (the "Terms of Sale Agreement"). The product may contain design defects or errors known as anomalies which may cause the product's functions to deviate from published specifications. Anomaly sheets are available upon request. SMSC products are not designed, intended, authorized or warranted for use in any life support or other application where product failure could cause or contribute to personal injury or severe property damage. Any and all such uses without prior written approval of an Officer of SMSC and further testing and/or modification will be fully at the risk of the customer. Copies of this document or other SMSC literature, as well as the Terms of Sale Agreement, may be obtained by visiting SMSC's website at <http://www.smsc.com>. SMSC is a registered trademark of Standard Microsystems Corporation ("SMSC"). Product names and company names are the trademarks of their respective holders.

SMSC DISCLAIMS AND EXCLUDES ANY AND ALL WARRANTIES, INCLUDING WITHOUT LIMITATION ANY AND ALL IMPLIED WARRANTIES OF MERCHANTABILITY, FITNESS FOR A PARTICULAR PURPOSE, TITLE, AND AGAINST INFRINGEMENT AND THE LIKE, AND ANY AND ALL WARRANTIES ARISING FROM ANY COURSE OF DEALING OR USAGE OF TRADE. IN NO EVENT SHALL SMSC BE LIABLE FOR ANY DIRECT, INCIDENTAL, INDIRECT, SPECIAL, PUNITIVE, OR CONSEQUENTIAL DAMAGES; OR FOR LOST DATA, PROFITS, SAVINGS OR REVENUES OF ANY KIND; REGARDLESS OF THE FORM OF ACTION, WHETHER BASED ON CONTRACT; TORT; NEGLIGENCE OF SMSC OR OTHERS; STRICT LIABILITY; BREACH OF WARRANTY; OR OTHERWISE; WHETHER OR NOT ANY REMEDY OF BUYER IS HELD TO HAVE FAILED OF ITS ESSENTIAL PURPOSE, AND WHETHER OR NOT SMSC HAS BEEN ADVISED OF THE POSSIBILITY OF SUCH DAMAGES.

PIN CONFIGURATION

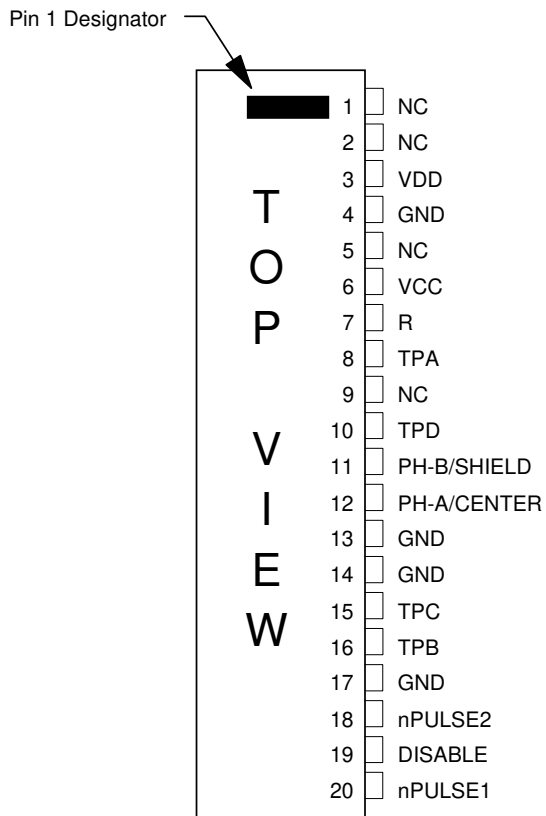

PACKAGE: 20-Pin SIP

DESCRIPTION OF PIN FUNCTIONS

PIN NO.	NAME	SYMBOL	DESCRIPTION
1, 2, 5, 9	No Connect	NC	Not used. Make no connection to these pins.
3	Power Supply	VDD	-5 Volts power supply.
4, 13, 14, 17	Ground	GND	Ground.
6	Power Supply	VCC	+5 Volts power supply.
7	Receive Data	RX	Output. This signal carries the TTL receive pulse information to the ARCNET LAN Controller Device.
8, 16, 15, 10	Test Points	TPA, TPB, TPC, TPD	Test points. Make no connection to these pins.
11	Phase-B/ Shield	PH-B/ SHIELD	Output. Connect this signal to Twisted Pair Connector pin 3 or the shield of the coaxial cable.
12	Phase-A/ Center	PH-A/ CENTER	Output. Connect this signal to Twisted Pair Connector pin 2 or the center of the coaxial cable.
18	nPulse 2	nPULSE2	Input. This signal is supplied by the ARCNET LAN Controller Device.
19	Disable TX	DISABLE TRANSMIT	Input. A high level on this signal disables the transmit section of the HYC9088. It is normally connected to ground.
20	nPulse 1	nPULSE1	Input. This signal is supplied by the ARCNET LAN Controller Device.

FUNCTIONAL DESCRIPTION

The HYC9088A HIT integrates a host of discrete components into a hybrid module and provides the Local Area Network designer with space and cost savings as well as the enhanced reliability of a single component. Since the HIT is a high impedance transceiver, it does not disturb the characteristic impedance of the cable used to interconnect ARCNET nodes. The two far ends of the twisted pair cable must be terminated using terminating resistors equal to the characteristic impedance of the cable. The HIT is made up of a transmit section and a receive section. (Please refer to Figure 1).

Transmit Section

The ARCNET LAN controller transmits a logic "1" by generating two 100 ns non-overlapping negative pulses, nPULSE1 and nPULSE2. These signals are converted by the HIT into a 200 ns dipulse signal. The HIT shapes the 200 ns signal into a single cycle of a 5 MHz sine-wave and filters higher frequency components. The dipulse signal is then transformer-coupled onto the cable and has a minimum voltage output of 16 Volts peak-to-peak. The exact output voltage of the HIT will vary depending on the characteristic impedance of the cable used. The driving circuitry of the HIT has been designed to present a high impedance on the cable in order to minimize loading.

The DISABLE input of the HYC9088 can be used to prevent the device from transmitting. During normal operation, the DISABLE input is tied to ground.

Receiver Section

The received dipulse signal from the cable is electrically isolated through the use of a transformer. This signal is passed through a filter which eliminates out of band noise. The receive signal is then fed to a comparator which converts it into a TTL signal ready to be applied to the LAN controller chip. The comparator compares the received signal to an internal voltage threshold to distinguish noise from real signal.

APPLICATION INFORMATION

Small Twisted Pair Networks

The HIT eliminates the need for active hubs in small ARCNET networks. For example, a ten node ARCNET network can be constructed by connecting ten HITs using a daisy-chained or bus configuration (see Figure 2). Note that both extremes of the cable must be terminated with a resistor which matches the characteristic impedance of the Twisted Pair Cable. For the cable types specified in Table 1, the maximum length of the twisted pair cable recommended is 400 feet.

Small Coax Network

No active hub is required for an ARCNET network consisting of eight nodes or less using the HYC9088 for coax cable (See Figure 2A). Both ends of the cable must be terminated with a resistor which matches the characteristic impedance of the coax cable. For the RG62 cable specified in Table 1, the maximum length of the coax cable recommended is 1000 feet.

Combination of Twisted Pair and Coax Networks

A Two-Port Link is used to combine twisted pair network and a coax network. A Two-Port Link has a coax connector on one side and two modular jacks on the other and contains the proper impedance-matching circuitry. Refer to Figure 3 for an illustration of a twisted pair network combined with a coaxial network.

Proper Connection for Twisted Pair

Each twisted pair compatible ARCNET node would typically have two RJ-11 modular connectors mounted on the node card (refer to Figure 4). PHASE A should be connected to pin 2 of the connectors and PHASE B to pin 3. A twisted pair segment would have an RJ-11 modular jack on each end (see Figure 5). Please note that the suggested numbering scheme of the modular jack shown in Figure 5 may not be consistent with that found on some manufacturers' products. Please ensure consistent connection of Phase A and Phase B signals throughout the network to avoid the reception of erroneous data.

Table 1 - Specifications for Cabling

PARAMETER	VALUE FOR COAX	VALUE FOR TWISTED PAIR
Wiring	RG62	Solid Copper 22, 24, or 26 AWG
Number of Twists/Foot	N/A	2 min.
DC Resistance	3.4 Ohms/1000 ft.	28.6 Ohms/1000 ft. max.
Characteristic Impedance	93 Ohms at 1 MHz	105 Ohms ± 20% at 1 MHz
Maximum Attenuation	5.5 dB/1000 ft. at 5 MHz	16.0 dB/1000 ft. at 5 MHz

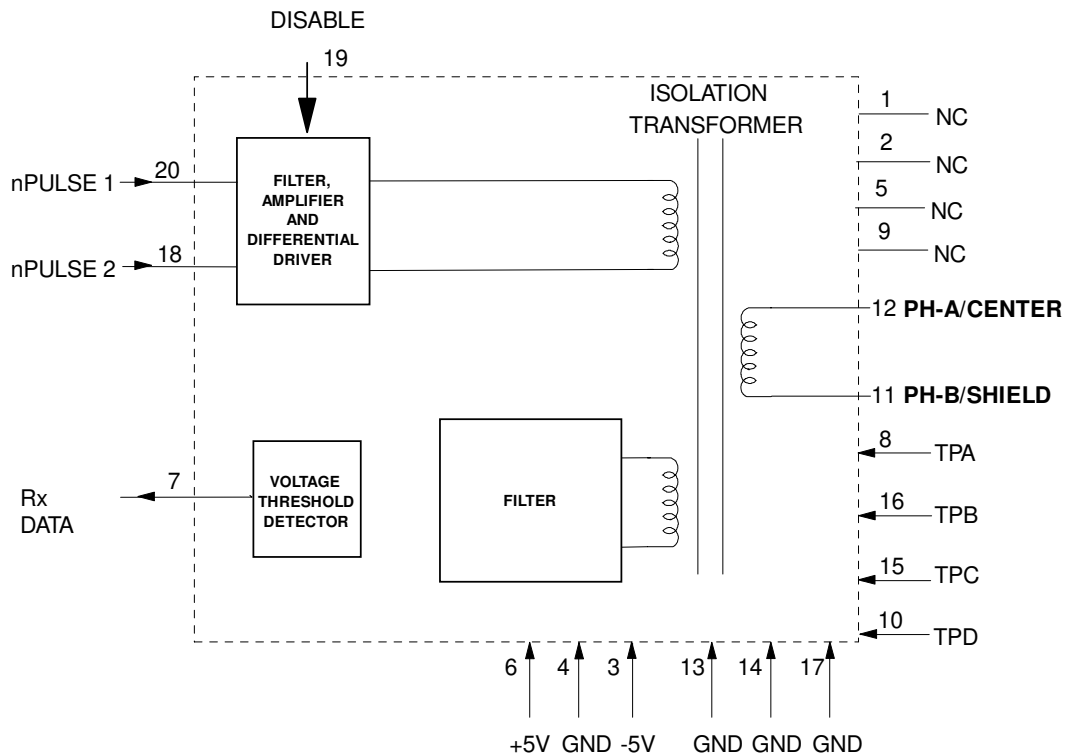

FIGURE 1 – HYC9088A INTERNAL BLOCK DIAGRAM

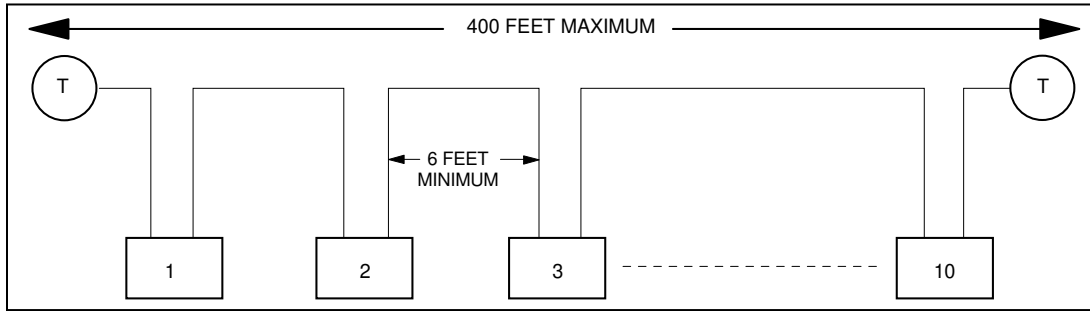

FIGURE 2 – TYPICAL SMALL TWISTED PAIR ARCNET NETWORK USING HYC9088A

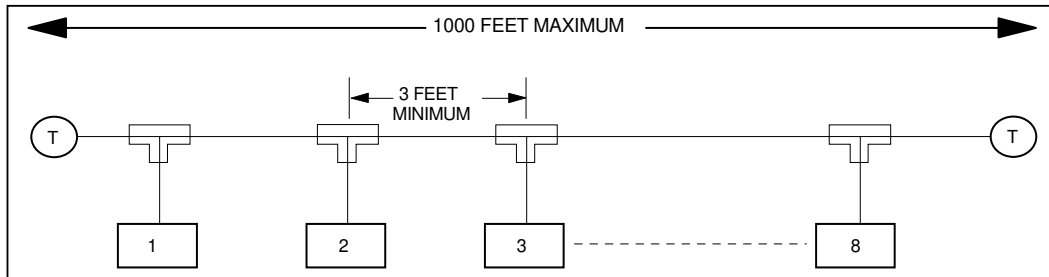
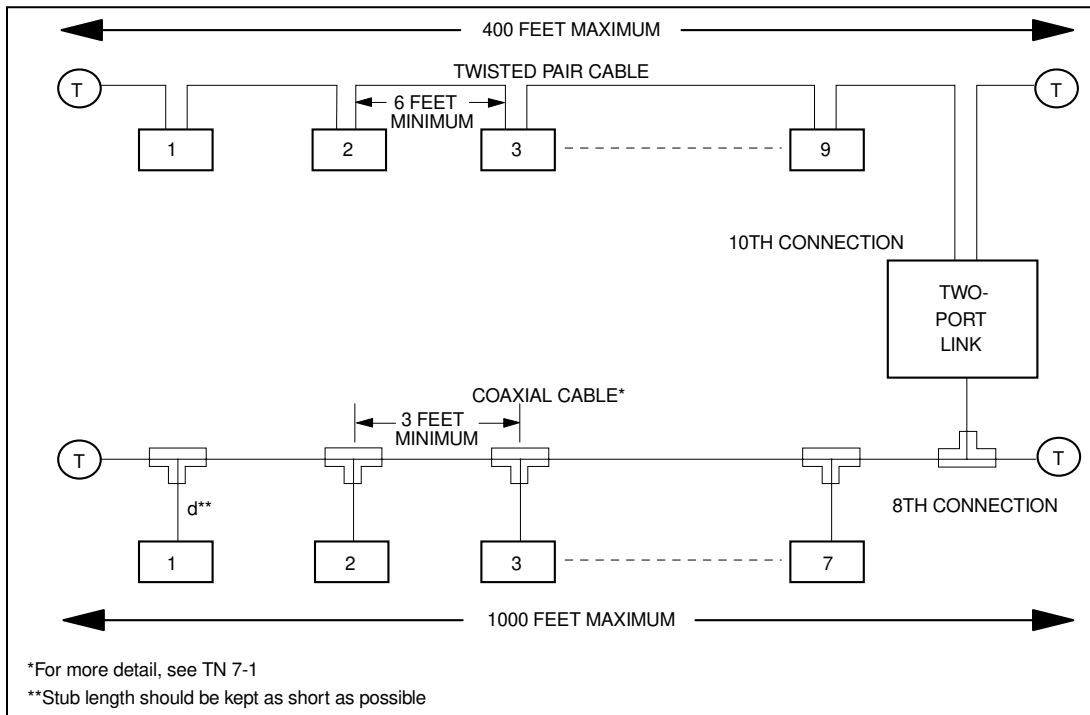

FIGURE 2A – TYPICAL SMALL COAX ARCNET NETWORK USING HYC9088A



*For more detail, see TN 7-1

**Stub length should be kept as short as possible

FIGURE 3 – TYPICAL COMBINATION OF TWISTED PAIR AND COAXIAL CABLE ON AN ARCNET NETWORK USING HYC9088A

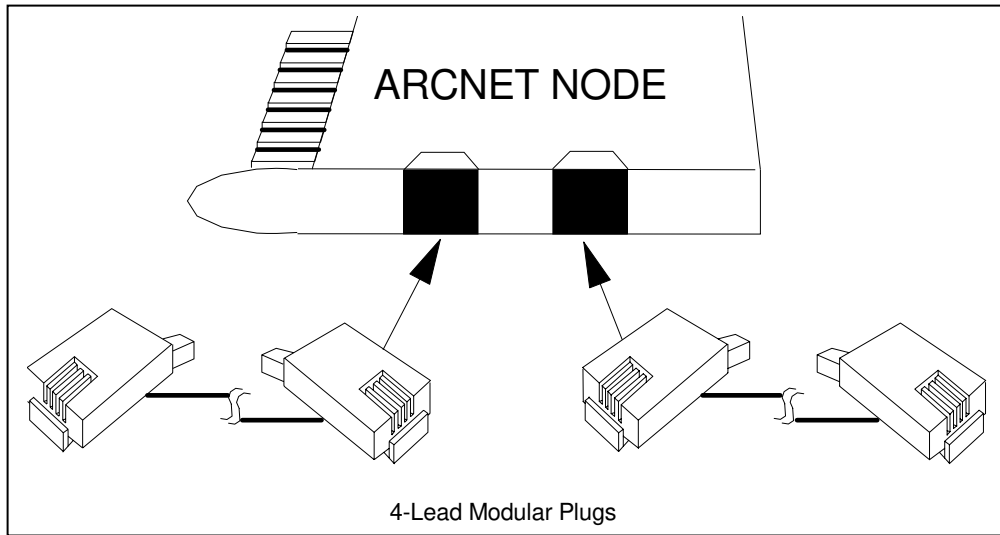

FIGURE 4 – RJ-11 CONNECTORS ON NODE CARD

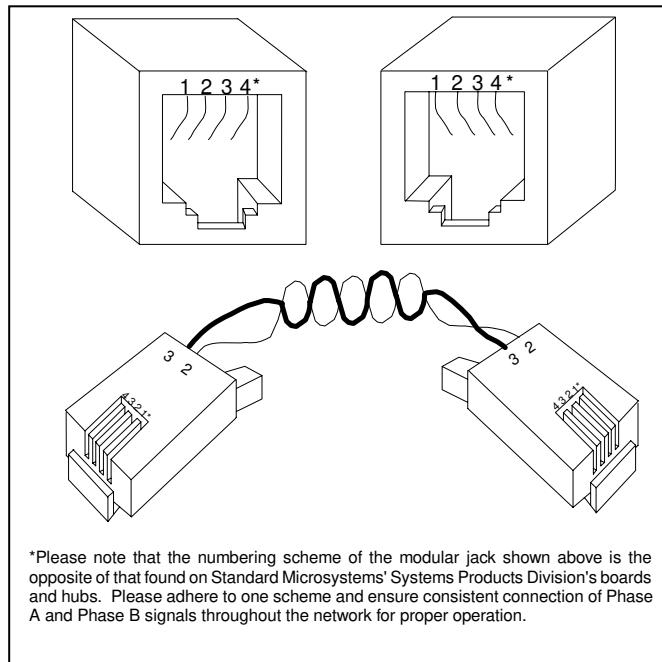

FIGURE 5 – PHASE RELATIONSHIP ON TWISTED PAIR SEGMENT AND RJ-11 CONNECTOR PINOUT

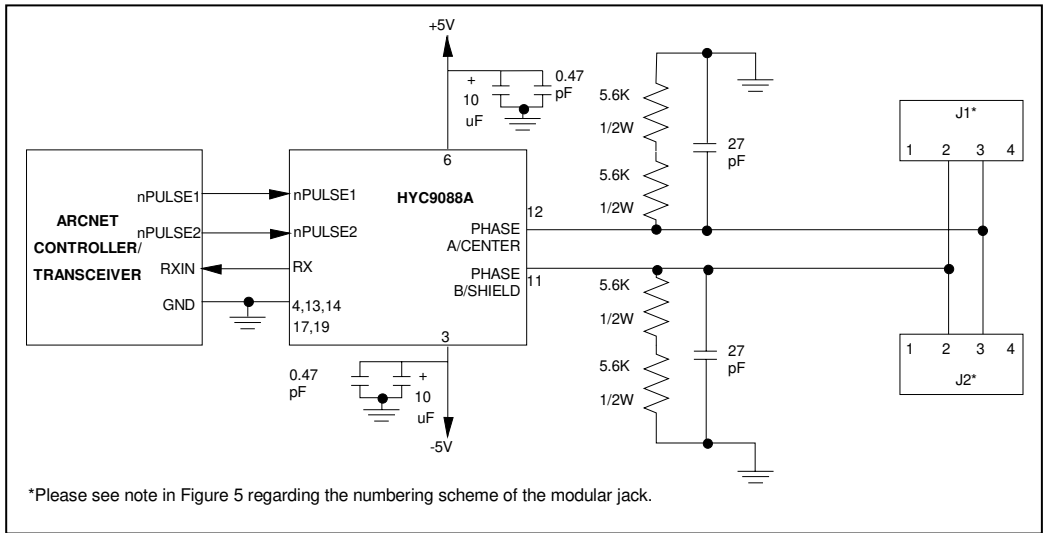

FIGURE 6 – TYPICAL HYC9088A INTERCONNECT FOR TWISTED PAIR CABLE

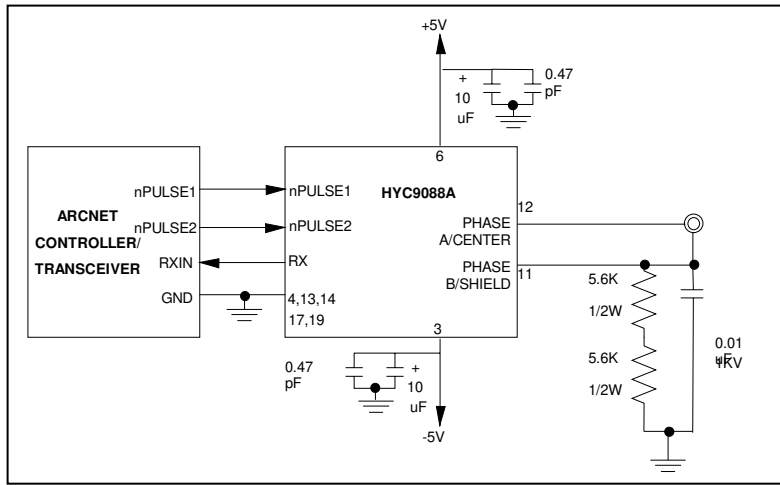

FIGURE 7 – TYPICAL HYC9088A INTERCONNECT FOR COAXIAL CABLE

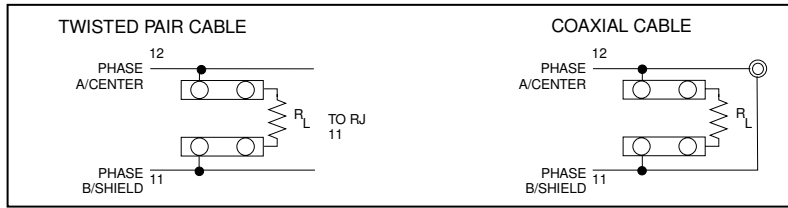

FIGURE 8 – DESCRIPTION OF TERMINATOR WIRING

OPERATIONAL DESCRIPTION

MAXIMUM GUARANTEED RATINGS*

Operating Temperature Range0°C to +70°C
 Storage Temperature Range -55° to +150°C
 Lead Temperature Range (soldering, 10 seconds) +325°C
 Positive Voltage on any pin, with respect to GroundV_{CC}+0.3V
 Negative Voltage on any pin, except V_{DD}, with respect to Ground -0.3V

*Stresses above those listed above could cause permanent damage to the device. This is a stress rating only and functional operation of the device at any other condition above those indicated in the operation sections of this specification is not implied.

Note: When powering this device from laboratory or system power supplies, it is important that the Absolute Maximum Ratings not be exceeded or device failure can result. Some power supplies exhibit voltage spikes on their outputs when the AC power is switched on or off. In addition, voltage transients on the AC power line may appear on the DC output. If this possibility exists, it is suggested that a clamp circuit be used.

DC ELECTRICAL CHARACTERISTICS (T_A = 0°C to 70°C, V_{CC2} = +5.0 V ± 5%, V_{DD} = -5.0V ± 5%)

PARAMETER	SYMBOL	MIN	TYP	MAX	UNITS	COMMENTS
Low Input Voltage	V _{IL}			0.8	V	I _{IL} = -0.8 mA
High Input Voltage	V _{IH}	2.0			V	I _{IH} = +0.2 mA
Received Signal Amplitude	V _R	6.0 3.0			V _{p-p} V _{o-p}	
Low Output Voltage	V _{OL}			0.4	V	One TTL Load
High Output Voltage	V _{OH}	2.4			V	One TTL Load
Transformer Output	V _T	16 8	20 10		V _{p-p} V _{O-p}	Z _{chr} cable = 120Ω or 93Ω
Cable Noise Amplitude	V _C			4	V _{p-p}	
V _{CC} Supply Current	I _{CC}		190	285	mA	
V _{DD} Supply Current	I _{DD}		180	270	mA	
Pulse Width, nPulse 1, n2	PW		100		nS	

Shorting the transformer output may cause permanent damage to the device.

HYC9088AR for Right Angle Lead Frame
 HYC9088AS for Straight Lead Frame

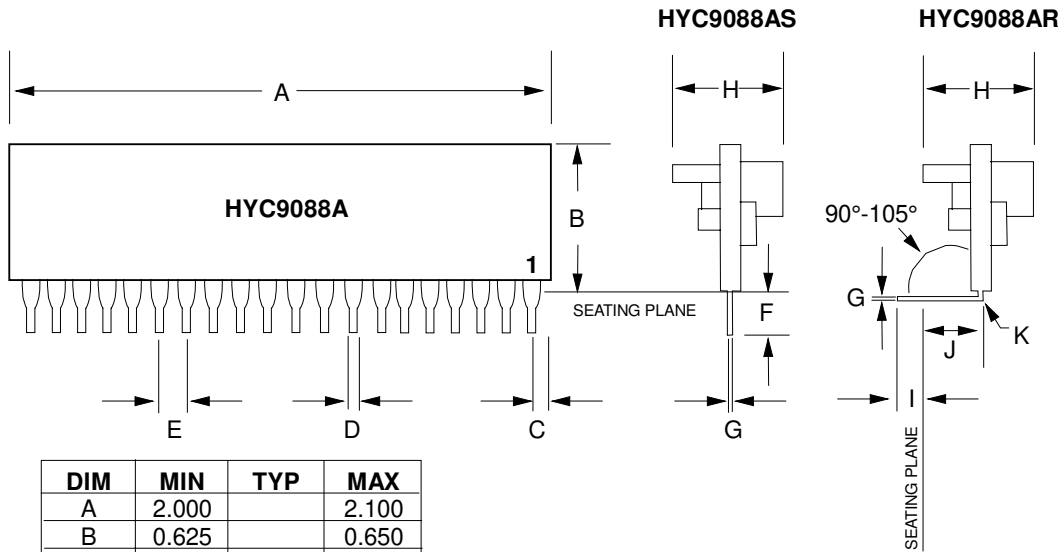

DIM	MIN	TYP	MAX
A	2.000		2.100
B	0.625		0.650
C	0.055		0.095
D	0.018		0.022
E		0.100	
F	0.120		0.135
G		0.010	
H			0.400
I	0.070		0.085
J		0.180	
K			0.020

NOTE: Dimensions are in inches

FIGURE 9 – 20 PIN SIP PACKAGE DIMENSIONS