



**ANATECH ELECTRONICS INC**  
RF & Microwave Filters & Products

# 1848 MHz Cavity Bandpass Filter

**Part Number: AE1848B9814**



## Electrical Specifications

**Center Frequency:** 1848 MHz  
**Bandwidth:** 1 MHz  
**Passband :** 1847 MHz to 1848 MHz  
**Insertion loss:** < 4dB  
**Return Loss:** >15dB  
**Impedance:** 50 Ohms  
**Rejection:** <50dB @ 0-1823 MHz  
**Rejection2:** <50dB @ 1873MHz to 6000 MHz

## Mechanical

**Mounting Method:** Threaded Mounting Holes  
**Connector Type:** SMA(Female)  
**Dimensions:** 4.50" X 1.750" x 1.0" in.

## Environmental

**Operating Temperature:** -25°C to +70°C  
**Storage Temperature:** -40°C to +90°C  
**Shock:** 20 G. 11ms  
**Vibration:** 20 G. 5 to 200Hz

## Outline Drawing:

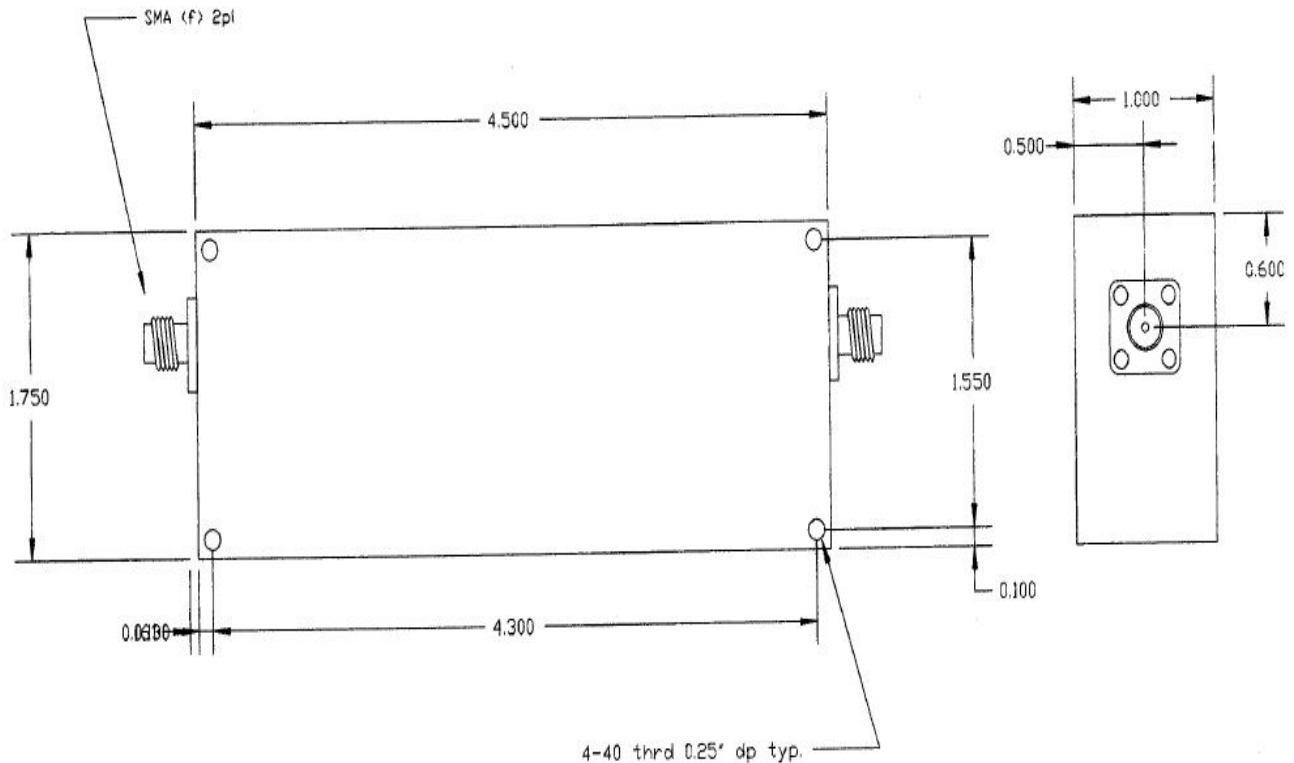



**Response Plot:**

