

**FEATURES**

- 1.8 V to 5.5 V single supply
- 4  $\Omega$  (max) on resistance
- 0.75  $\Omega$  (typ) on resistance flatness
- 3 dB bandwidth > 200 MHz
- Rail-to-rail operation
- 6-lead SOT-23 package
- Fast switching times:
  - $t_{ON} = 12$  ns
  - $t_{OFF} = 6$  ns
- Typical power consumption: (< 0.01  $\mu$ W)
- TTL/CMOS compatible
- Military temperature range: -55°C to +125°C

**APPLICATIONS**

- Battery-powered systems
- Communication systems
- Sample-and-hold systems
- Audio signal routing
- Video switching
- Mechanical reed relay replacement

**GENERAL DESCRIPTION**

The ADG719-EP is a monolithic CMOS SPDT switch. This switch is designed on a submicron process that provides low power dissipation yet gives high switching speed, low on resistance, and low leakage currents.

The ADG719-EP can operate from a single-supply range of 1.8 V to 5.5 V, making it ideal for use in battery-powered instruments and with the new generation of DACs and ADCs from Analog Devices, Inc.

Each switch of the ADG719-EP conducts equally well in both directions when on. The ADG719-EP exhibits break-before-make switching action.

Because of the advanced submicron process, -3 dB bandwidths of greater than 200 MHz can be achieved.

The ADG719-EP is available in a 6-lead SOT-23 package.

Full details about this enhanced product are available in the [ADG719](#) data sheet, which should be consulted in conjunction with this data sheet.

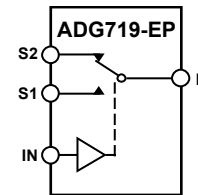
**FUNCTIONAL BLOCK DIAGRAM**

NOTES  
1. SWITCHES SHOWN FOR A LOGIC 1 INPUT.

00842-001

Figure 1.

**PRODUCT HIGHLIGHTS**

1. Supports defense and aerospace applications (AQEC standard).
2. Military temperature range: -55°C to +125°C.
3. Controlled manufacturing baseline.
4. One assembly and test site.
5. One fabrication site.
6. Enhanced product change notification.
7. Qualification data available on request.

**Rev. 0**

Information furnished by Analog Devices is believed to be accurate and reliable. However, no responsibility is assumed by Analog Devices for its use, nor for any infringements of patents or other rights of third parties that may result from its use. Specifications subject to change without notice. No license is granted by implication or otherwise under any patent or patent rights of Analog Devices. Trademarks and registered trademarks are the property of their respective owners.

## TABLE OF CONTENTS

Features .....	1	Absolute Maximum Ratings .....	5
Applications.....	1	ESD Caution.....	5
Functional Block Diagram .....	1	Pin Configuration and Function Descriptions.....	6
General Description .....	1	Typical Performance Characteristics .....	7
Product Highlights .....	1	Test Circuits.....	9
Revision History .....	2	Outline Dimensions .....	11
Specifications.....	3	Ordering Guide .....	11

## REVISION HISTORY

4/10—Revision 0: Initial Version

## SPECIFICATIONS

$V_{DD} = 5\text{ V} \pm 10\%$ ,  $GND = 0\text{ V}$ .

**Table 1.**

Parameter	+25°C	−55°C to +125°C	Unit	Test Conditions/Comments
<b>ANALOG SWITCH</b>				
Analog Signal Range		0 V to $V_{DD}$	V	
On Resistance ( $R_{ON}$ )	2.5		$\Omega$ typ	$V_S = 0\text{ V to }V_{DD}$ , $I_S = -10\text{ mA}$ ;
	4	7	$\Omega$ max	see Figure 13
On Resistance Match Between Channels ( $\Delta R_{ON}$ )	0.1		$\Omega$ typ	$V_S = 0\text{ V to }V_{DD}$ , $I_S = -10\text{ mA}$
		0.4	$\Omega$ max	
On Resistance Flatness ( $R_{FLAT(ON)}$ )	0.75		$\Omega$ typ	$V_S = 0\text{ V to }V_{DD}$ , $I_S = -10\text{ mA}$
		1.5	$\Omega$ max	
<b>LEAKAGE CURRENTS <math>I_S</math> (Off)</b>				
Source Off Leakage	$\pm 0.01$		nA typ	$V_{DD} = 5.5\text{ V}$
	$\pm 0.25$	1	nA max	$V_S = 4.5\text{ V/1 V}$ , $V_D = 1\text{ V/4.5 V}$ ;
Channel On Leakage $I_D$ , $I_S$ (On)	$\pm 0.01$		nA typ	see Figure 14
	$\pm 0.25$	5	nA max	$V_S = V_D = 1\text{ V or }V_S = V_D = 4.5\text{ V}$ ;
				see Figure 15
<b>DIGITAL INPUTS</b>				
Input High Voltage, $V_{INH}$		2.4	V min	
Input Low Voltage, $V_{INL}$		0.8	V max	
Input Current				
$I_{INL}$ or $I_{INH}$	0.005		$\mu\text{A typ}$	$V_{IN} = V_{INL}$ or $V_{INH}$
		$\pm 0.1$	$\mu\text{A max}$	
<b>DYNAMIC CHARACTERISTICS<sup>1</sup></b>				
$t_{ON}$	7		ns typ	$R_L = 300\ \Omega$ , $C_L = 35\text{ pF}$
		12	ns max	$V_S = 3\text{ V}$ ; see Figure 16
$t_{OFF}$	3		ns typ	$R_L = 300\ \Omega$ , $C_L = 35\text{ pF}$
		6	ns max	$V_S = 3\text{ V}$ ; see Figure 16
Break-Before-Make Time Delay, $t_D$	8		ns typ	$R_L = 300\ \Omega$ , $C_L = 35\text{ pF}$ ,
		1	ns min	$V_{S1} = V_{S2} = 3\text{ V}$ ; see Figure 17
Off Isolation	−67		dB typ	$R_L = 50\ \Omega$ , $C_L = 5\text{ pF}$ , $f = 10\text{ MHz}$
	−87		dB typ	$R_L = 50\ \Omega$ , $C_L = 5\text{ pF}$ , $f = 1\text{ MHz}$ ;
				see Figure 18
Channel-to-Channel Crosstalk	−62		dB typ	$R_L = 50\ \Omega$ , $C_L = 5\text{ pF}$ , $f = 10\text{ MHz}$
	−82		dB typ	$R_L = 50\ \Omega$ , $C_L = 5\text{ pF}$ , $f = 1\text{ MHz}$ ;
				see Figure 19
Bandwidth −3 dB	200		MHz typ	$R_L = 50\ \Omega$ , $C_L = 5\text{ pF}$ ; see Figure 20
$C_S$ (Off)	7		pF typ	
$C_D$ , $C_S$ (On)	27		pF typ	
<b>POWER REQUIREMENTS</b>				
$I_{DD}$	0.001		$\mu\text{A typ}$	$V_{DD} = 5.5\text{ V}$
		1.0	$\mu\text{A max}$	Digital inputs = 0 V or 5.5 V

<sup>1</sup> Guaranteed by design, not subject to production test.

# ADG719-EP

$V_{DD} = 3\text{ V} \pm 10\%$ ,  $GND = 0\text{ V}$ .

**Table 2.**

Parameter	+25°C	-55°C to +125°C	Unit	Test Conditions/Comments
<b>ANALOG SWITCH</b>				
Analog Signal Range		0 V to $V_{DD}$	V	
On Resistance ( $R_{ON}$ )	6	12	$\Omega$ typ $\Omega$ max	$V_S = 0\text{ V to }V_{DD}$ , $I_S = -10\text{ mA}$ ; see Figure 13
On Resistance Match Between Channels ( $\Delta R_{ON}$ )	0.1	0.4	$\Omega$ typ $\Omega$ max	$V_S = 0\text{ V to }V_{DD}$ , $I_S = -10\text{ mA}$
On Resistance Flatness ( $R_{FLAT(ON)}$ )		2.5	$\Omega$ max $\Omega$ typ	$V_S = 0\text{ V to }V_{DD}$ , $I_S = -10\text{ mA}$
<b>LEAKAGE CURRENTS</b>				
Source Off Leakage $I_S$ (Off)	$\pm 0.01$ $\pm 0.25$	1	nA typ nA max	$V_{DD} = 3.3\text{ V}$ $V_S = 3\text{ V}/1\text{ V}$ , $V_D = 1\text{ V}/3\text{ V}$ ; see Figure 14
Channel On Leakage $I_D$ , $I_S$ (On)	$\pm 0.01$ $\pm 0.25$	5	nA typ nA max	$V_S = V_D = 1\text{ V}$ or $V_S = V_D = 3\text{ V}$ ; see Figure 15
<b>DIGITAL INPUTS</b>				
Input High Voltage, $V_{INH}$		2.0	V min	
Input Low Voltage, $V_{INL}$		0.8	V max	
Input Current $I_{INL}$ or $I_{INH}$	0.005	$\pm 0.1$	$\mu\text{A}$ typ $\mu\text{A}$ max	$V_{IN} = V_{INL}$ or $V_{INH}$
<b>DYNAMIC CHARACTERISTICS<sup>1</sup></b>				
$t_{ON}$	10	15	ns typ ns max	$R_L = 300\ \Omega$ , $C_L = 35\text{ pF}$ $V_S = 2\text{ V}$ ; see Figure 16
$t_{OFF}$	4	8	ns typ ns max	$R_L = 300\ \Omega$ , $C_L = 35\text{ pF}$ $V_S = 2\text{ V}$ ; see Figure 16
Break-Before-Make Time Delay, $t_D$	8	1	ns typ ns min	$R_L = 300\ \Omega$ , $C_L = 35\text{ pF}$ $V_{S1} = V_{S2} = 2\text{ V}$ ; see Figure 17
Off Isolation	-67 -87		dB typ dB typ	$R_L = 50\ \Omega$ , $C_L = 5\text{ pF}$ , $f = 10\text{ MHz}$ $R_L = 50\ \Omega$ , $C_L = 5\text{ pF}$ , $f = 1\text{ MHz}$ ; see Figure 18
Channel-to-Channel Crosstalk	-62 -82		dB typ dB typ	$R_L = 50\ \Omega$ , $C_L = 5\text{ pF}$ , $f = 10\text{ MHz}$ $R_L = 50\ \Omega$ , $C_L = 5\text{ pF}$ , $f = 1\text{ MHz}$ ; see Figure 19
Bandwidth -3 dB	200		MHz typ	$R_L = 50\ \Omega$ , $C_L = 5\text{ pF}$ ; see Figure 20
$C_S$ (Off)	7		pF typ	
$C_D$ , $C_S$ (On)	27		pF typ	
<b>POWER REQUIREMENTS</b>				
$I_{DD}$	0.001 1.0		$\mu\text{A}$ typ $\mu\text{A}$ max	$V_{DD} = 3.3\text{ V}$ Digital inputs = 0 V or 3.3 V

<sup>1</sup> Guaranteed by design, not subject to production test.

## ABSOLUTE MAXIMUM RATINGS

$T_A = 25^\circ\text{C}$ , unless otherwise noted.

**Table 3.**

Parameter	Rating
$V_{DD}$ to GND	$-0.3\text{ V to }+7\text{ V}$
Analog, Digital Inputs <sup>1</sup>	$-0.3\text{ V to }V_{DD} + 0.3\text{ V}$ or 30 mA, whichever occurs first
Peak Current, S or D	100 mA (Pulsed at 1 ms, 10% duty cycle max)
Continuous Current, S or D	30 mA
Operating Temperature Range	$-55^\circ\text{C to }+125^\circ\text{C}$
Storage Temperature Range	$-65^\circ\text{C to }+150^\circ\text{C}$
Junction Temperature	$150^\circ\text{C}$
SOT-23 Package	
$\theta_{JA}$ Thermal Impedance <sup>2</sup>	$186.45^\circ\text{C/W}$
Lead Soldering	
Reflow, Peak Temperature	$260(+0/-5)^\circ\text{C}$
Time at Peak Temperature	20 sec to 40 sec
ESD	1 kV

<sup>1</sup>Overvoltages at IN, S, or D will be clamped by internal diodes. Current should be limited to the maximum ratings given

<sup>2</sup>Measured on a 4-layer board.

Stresses above those listed under Absolute Maximum Ratings may cause permanent damage to the device. This is a stress rating only; functional operation of the device at these or any other conditions above those indicated in the operational section of this specification is not implied. Exposure to absolute maximum rating conditions for extended periods may affect device reliability.

Only one maximum rating may be applied at any one time.

### ESD CAUTION



**ESD (electrostatic discharge) sensitive device.** Charged devices and circuit boards can discharge without detection. Although this product features patented or proprietary protection circuitry, damage may occur on devices subjected to high energy ESD. Therefore, proper ESD precautions should be taken to avoid performance degradation or loss of functionality.

# ADG719-EP

## PIN CONFIGURATION AND FUNCTION DESCRIPTIONS

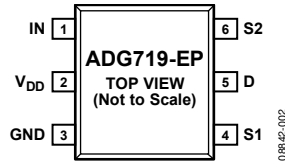

Figure 2. 6-Lead SOT-23 Pin Configuration

Table 4. Pin description

Pin No.	Mnemonic	Description
1	IN	Digital Switch Control Pin.
2	VDD	Most Positive Power Supply Pin.
3	GND	Ground (0 V) Reference Pin.
4	S1	Source Terminal. Can be used as an input or output.
5	D	Drain Terminal. Can be used as an input or output.
6	S2	Source Terminal. Can be used as an input or output.

Table 5. Truth Table

ADG719-EP IN	Switch S1	Switch S2
0	On	Off
1	Off	On

# TYPICAL PERFORMANCE CHARACTERISTICS

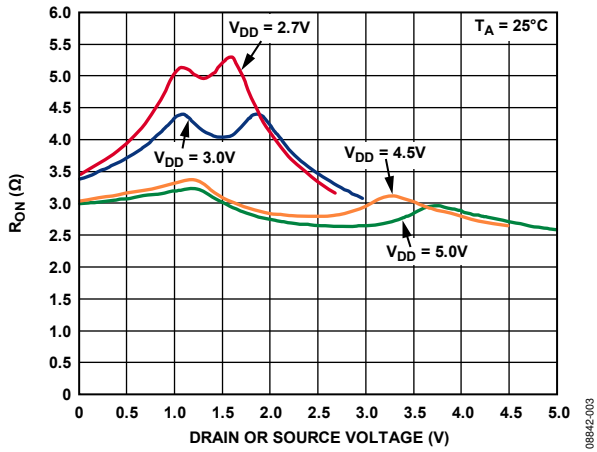

Figure 3. On Resistance vs.  $V_D$  ( $V_S$ ), Single Supplies

08942-003

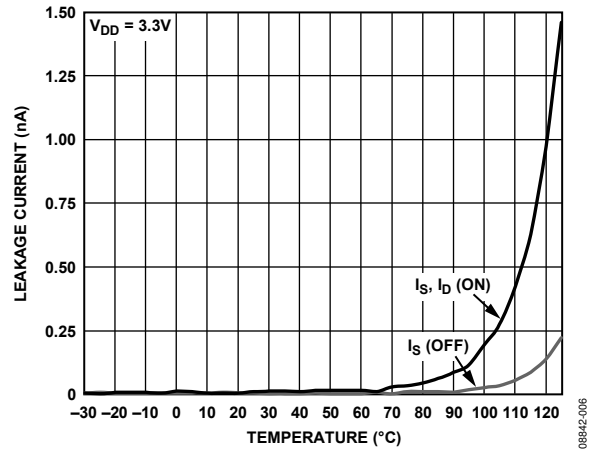

Figure 6. Leakage Currents vs. Temperature

08942-006

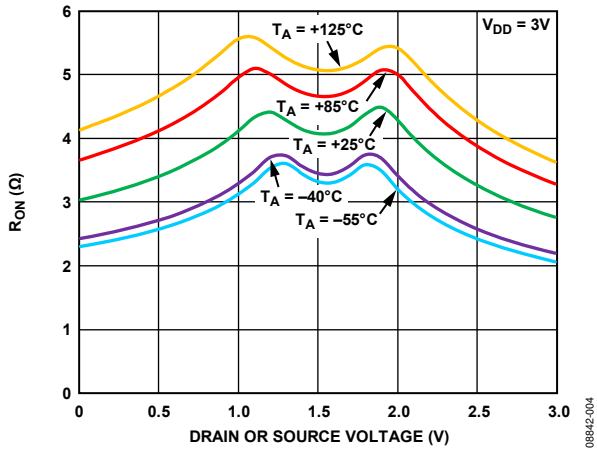

Figure 4. On Resistance vs.  $V_D$  ( $V_S$ ) for Different Temperatures,  $V_{DD} = 3V$

08942-004

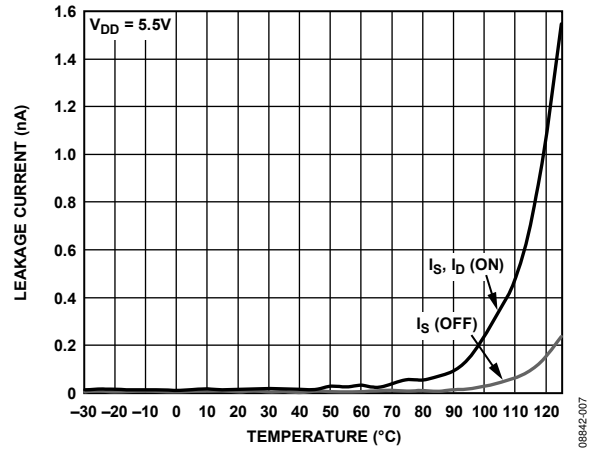

Figure 7. Leakage Currents vs. Temperature

08942-007

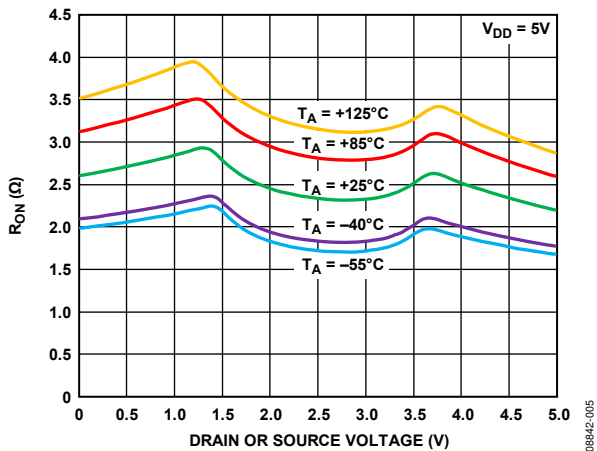

Figure 5. On Resistance vs.  $V_D$  ( $V_S$ ) for Different Temperatures,  $V_{DD} = 5V$

08942-005

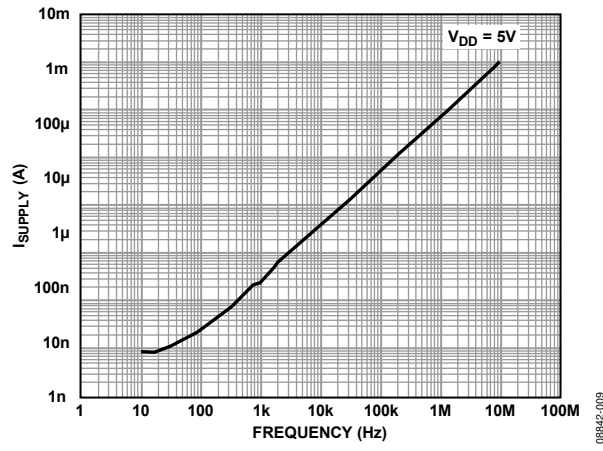

Figure 8. Supply Current vs. Input Switching Frequency

08942-009

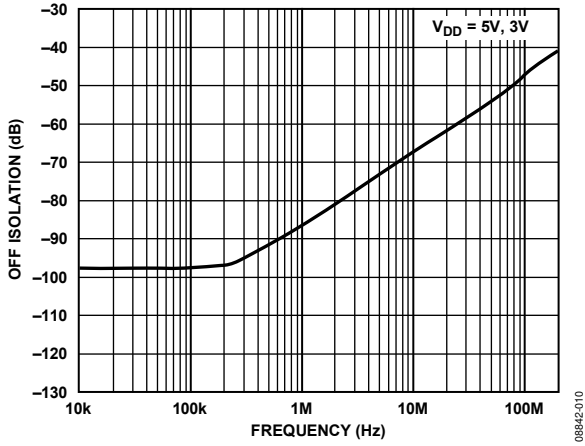

Figure 9. Off Isolation vs. Frequency

08842-010

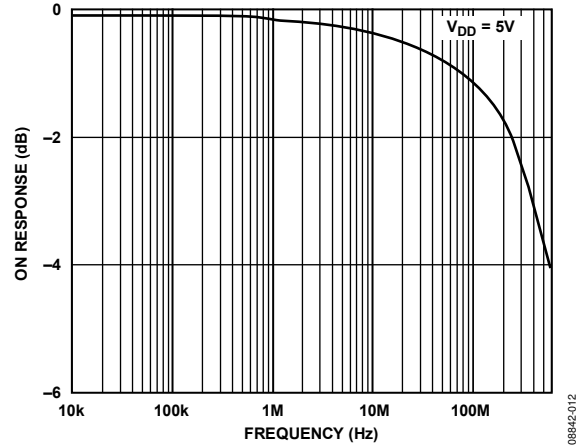

Figure 11. On Response vs. Frequency

08842-012

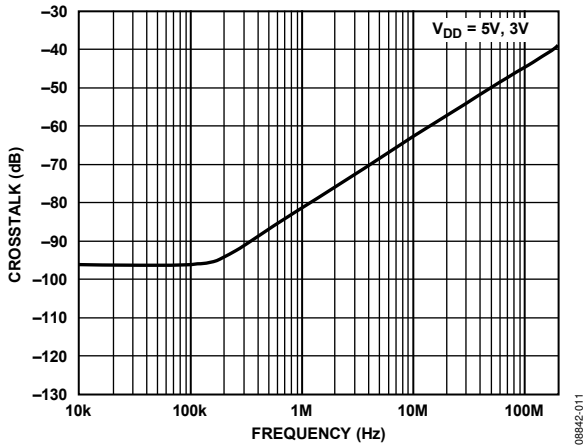

Figure 10. Crosstalk vs. Frequency

08842-011

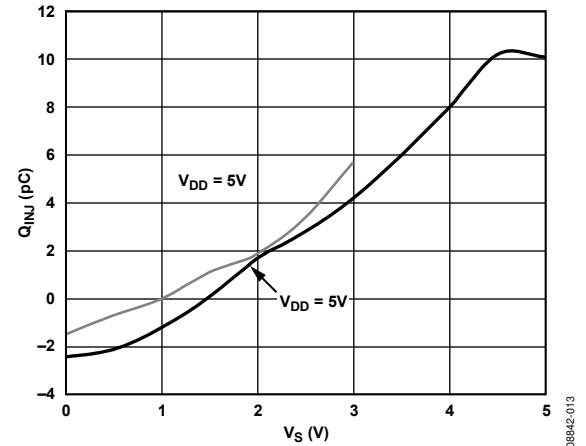

Figure 12. Charge Injection vs. Source Voltage

08842-013



### TEST CIRCUITS

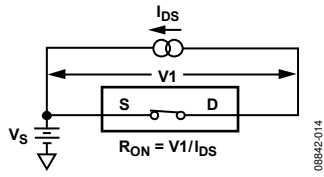

Figure 13. On Resistance

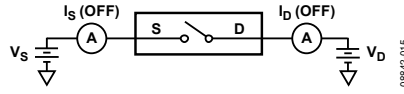

Figure 14. Off Leakage

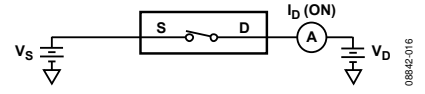

Figure 15. On Leakage

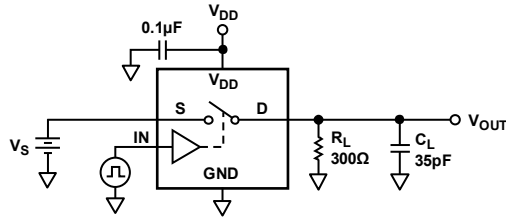

Figure 16. Switching Times

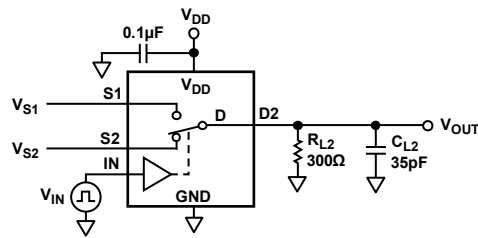

Figure 17. Break-Before-Make Time Delay,  $t_D$

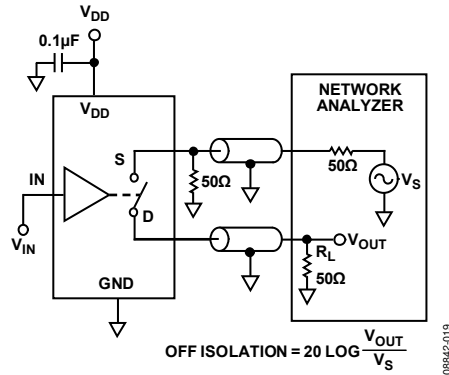

Figure 18. Off Isolation

08842-019

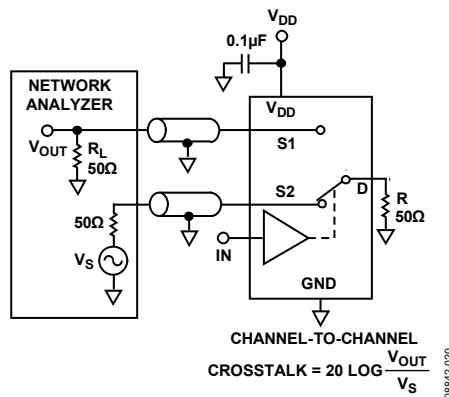

Figure 19. Channel-to-Channel Crosstalk

08842-020

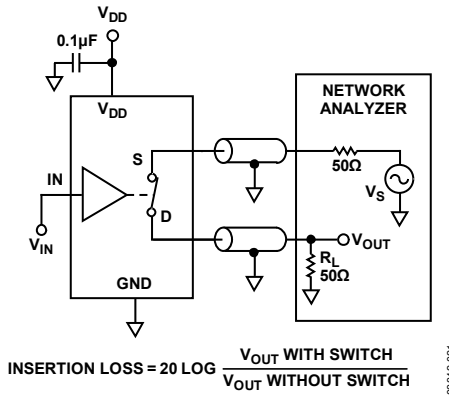
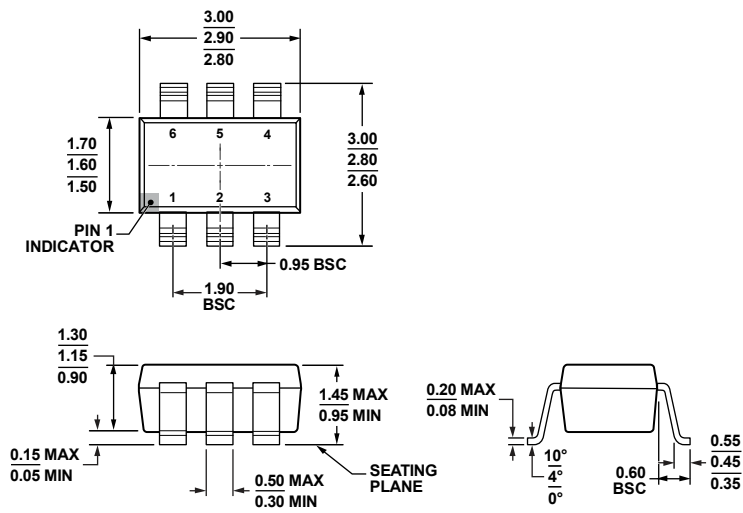

Figure 20. Bandwidth

08842-021

# OUTLINE DIMENSIONS



COMPLIANT TO JEDEC STANDARDS MO-178-AB  
 Figure 21. 6-Lead Small Outline Transistor Package [SOT-23]  
 (RJ-6)  
 Dimensions shown in millimeters

121609-A

## ORDERING GUIDE

Model <sup>1</sup>	Temperature Range	Package Description	Package Option	Branding
ADG719SRJZ-EP-RL7	-55°C to +125°C	6-Lead SOT-23	RJ-6	S3T

<sup>1</sup> Z = RoHS Compliant Part.

**ADG719-EP**

**NOTES**