

REVISIONS					
P	LTR	DESCRIPTION	DATE	DWN	APVD
E		REVISED PER ECR-18-011569	12DEC2018	KL	SB
F		REVISED PER ECR-20-001494	04FEB2020	SC	-
G		REVISED PER ECR-20-009426	05AUG2020	SC	-
H		REVISED PER ECR-21-113729	15SEP2021	SC	-

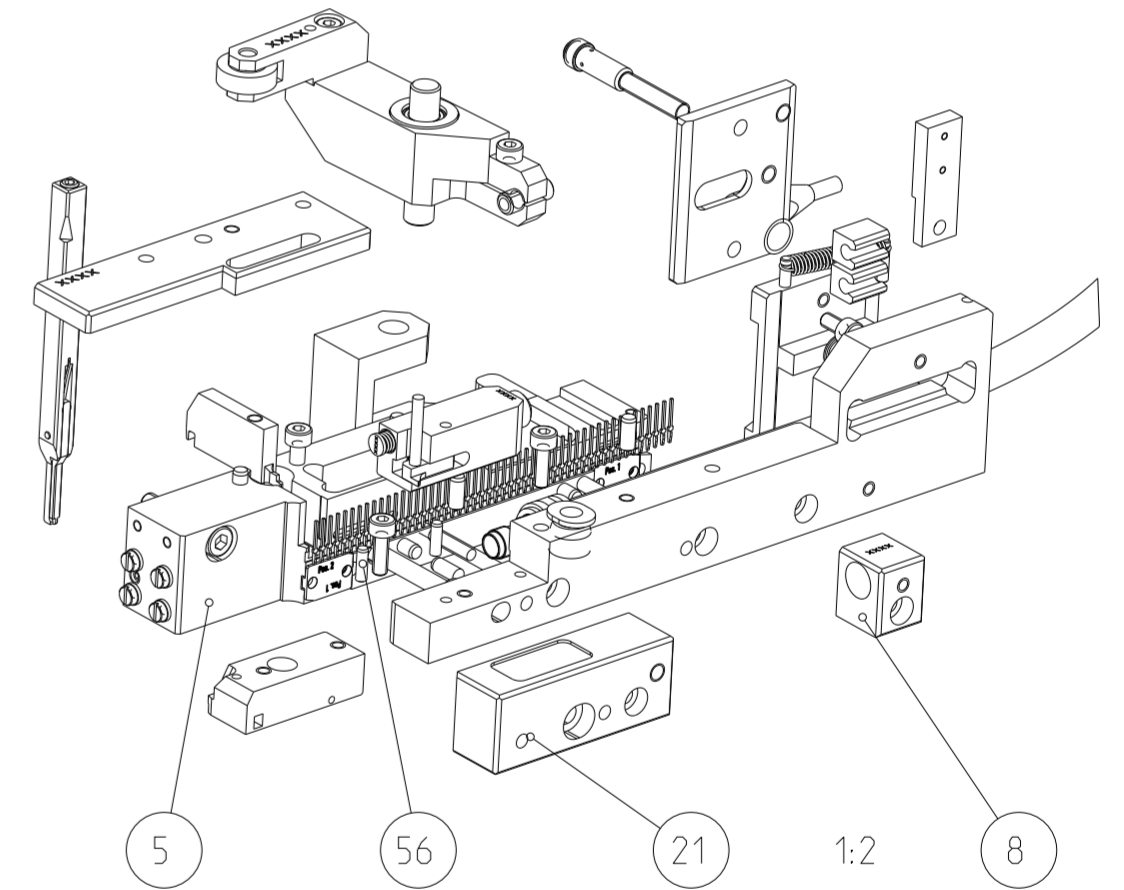
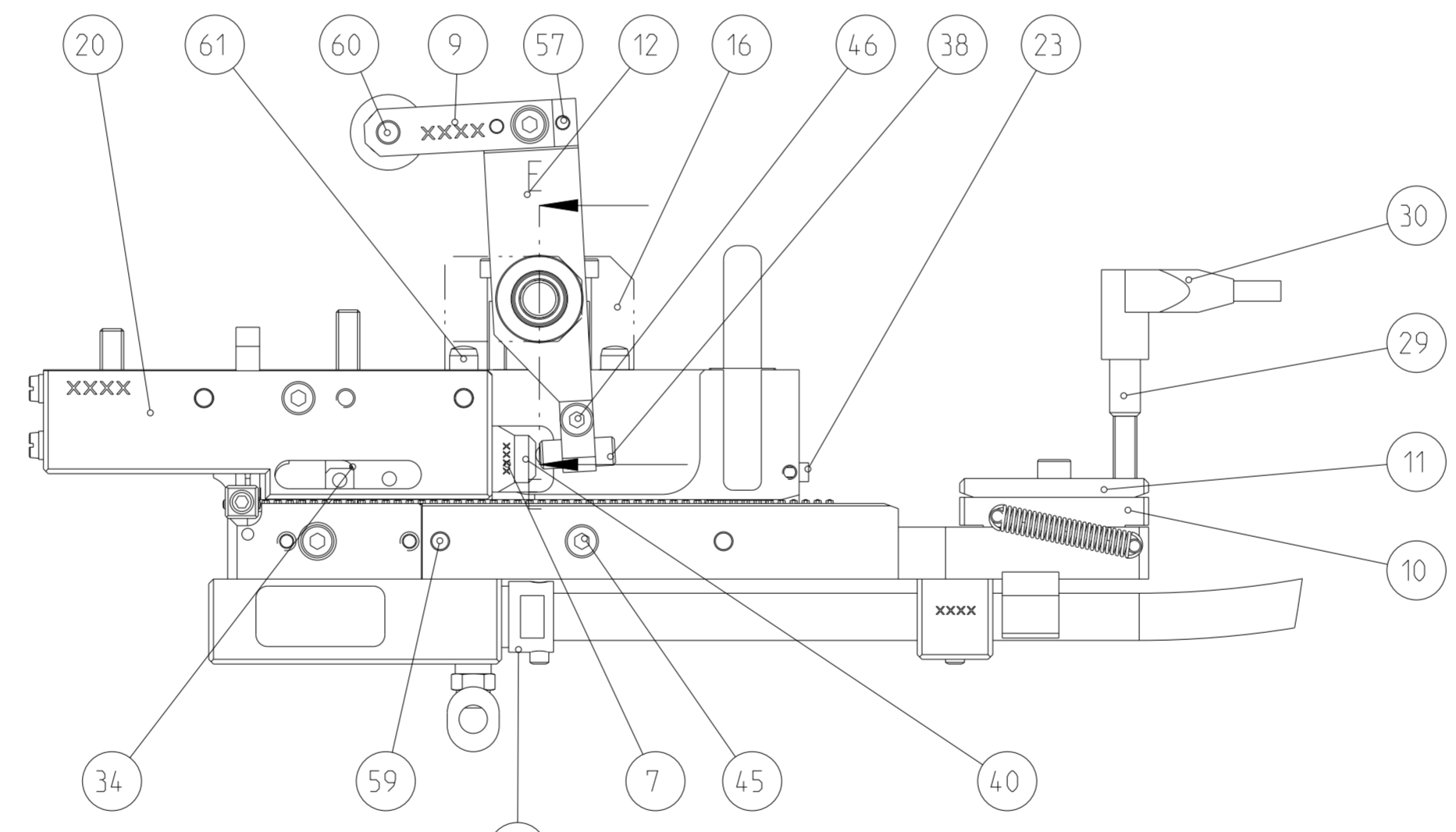
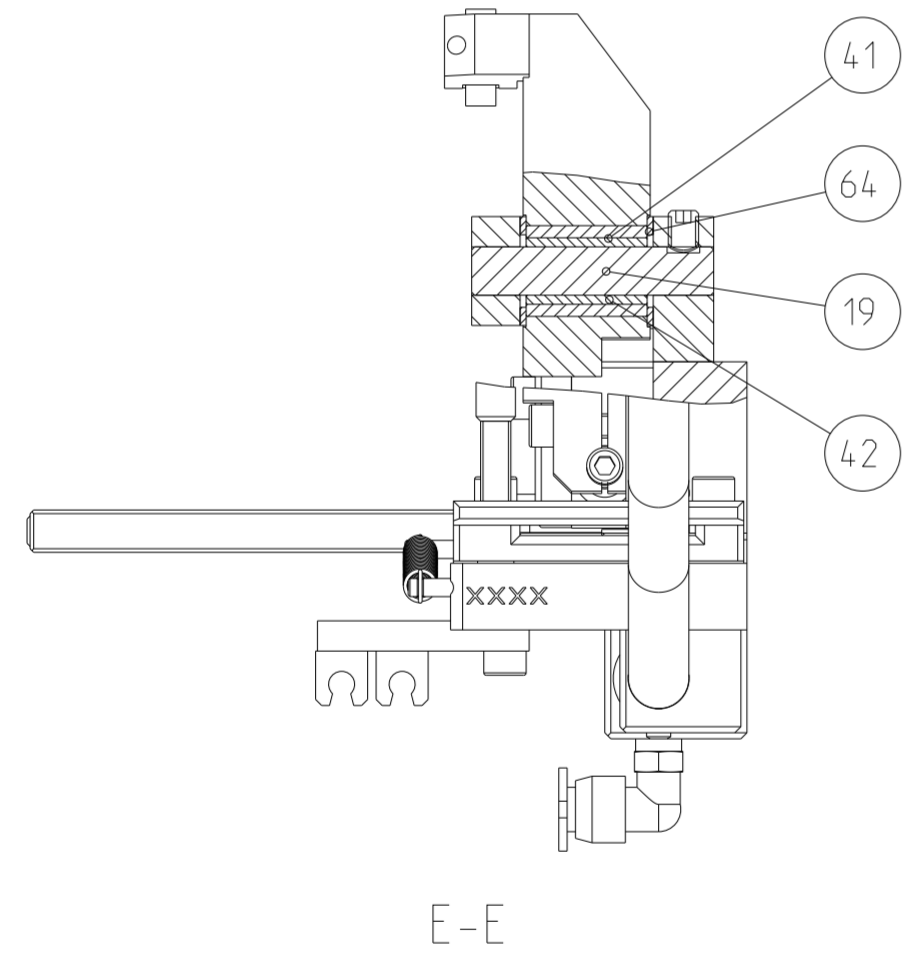
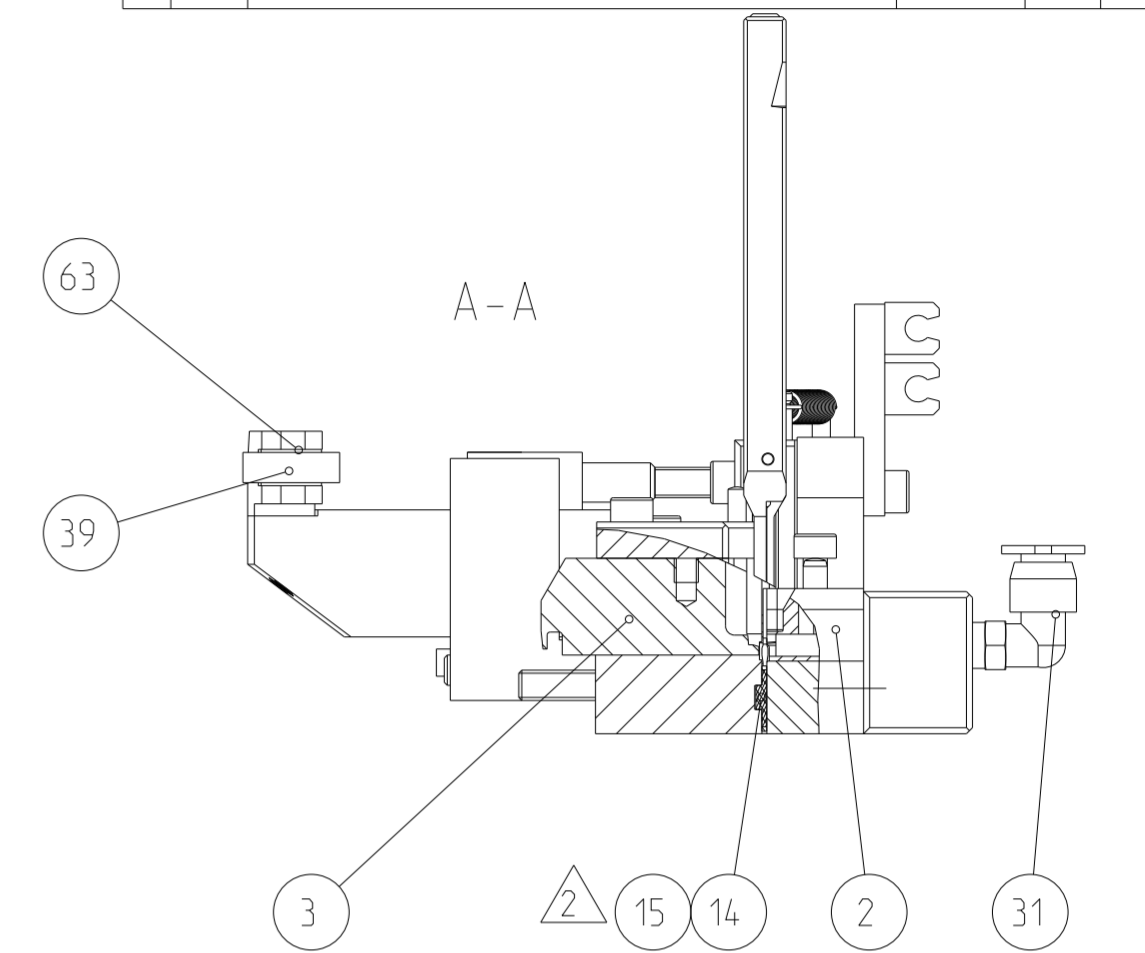
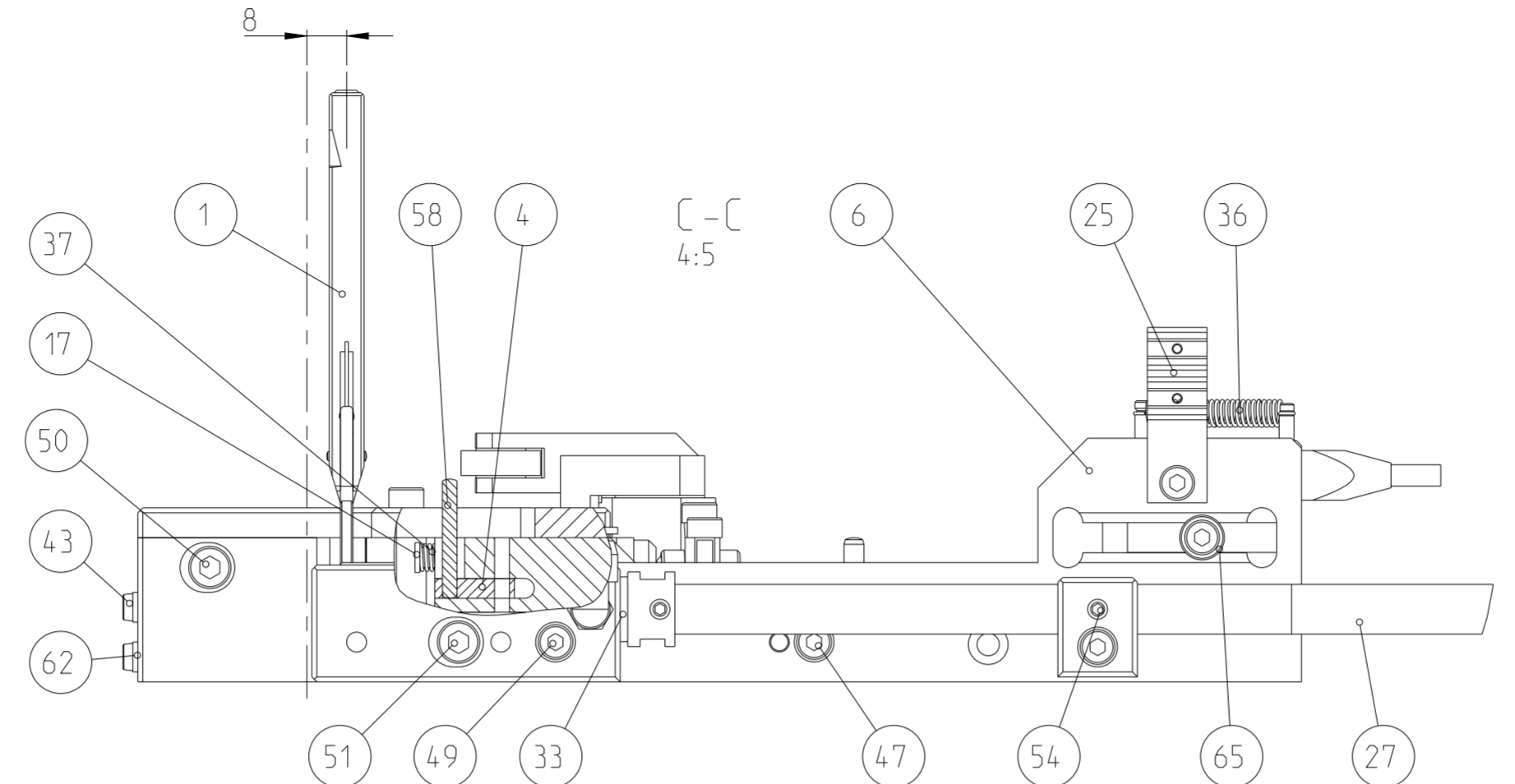
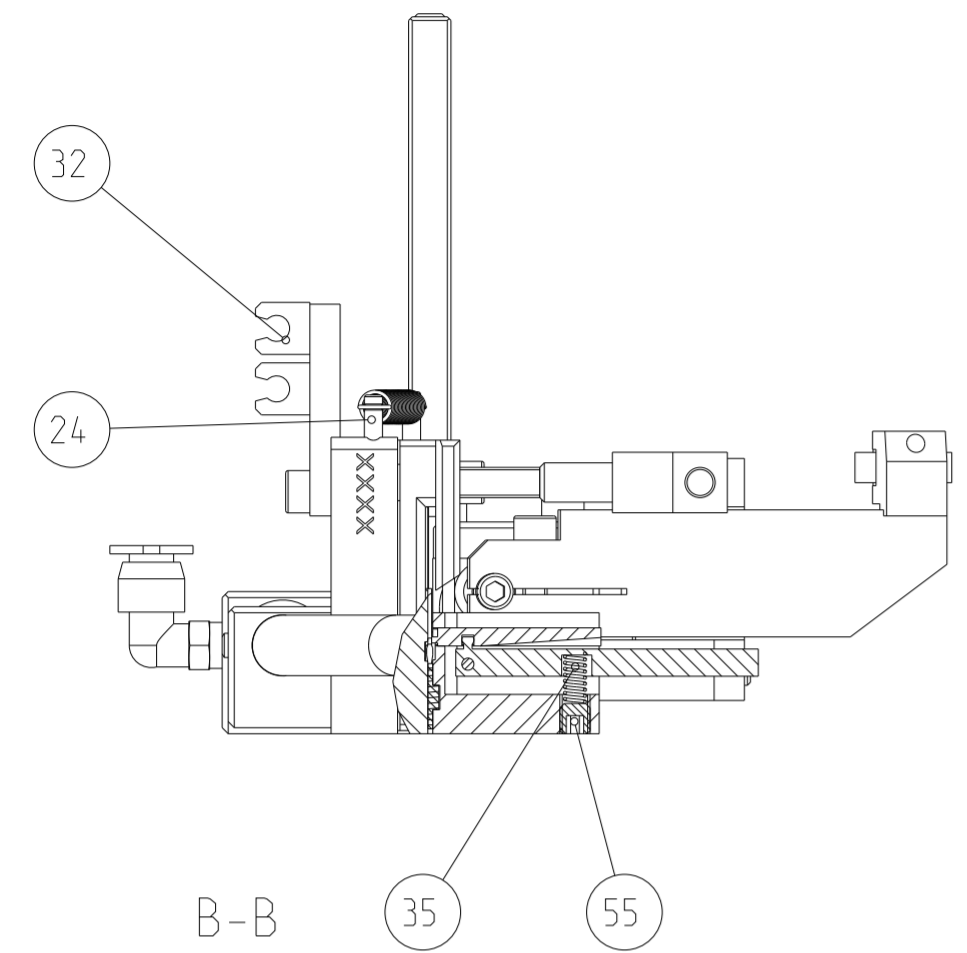

26 Mit Gewindedichtung Loctite 511 einschrauben  
 screw in with Loctite 511

⚠ Montagestelle der Stücklistenposition 14  
 Mounting location of BOM table position 14

Tabelle für spezifische Kontakteinstellungen:  
 (Maßklärung siehe Skizze)  
 Table for specific pin settings:  
 (measurement explanation see sketch)

Bedienungsanleitung für Umbausatz (= PN 4-744016-3) beachten!  
 Follow operating instruction for conversion kit (= PN 4-744016-3)!

⚠	Maß "A" Dimension "A"	Maß "B" Dimension "B"
6-1372442-7_Pos.1	> 3 mm	< 4.5 mm
6-1372442-7_Pos.2	> 3.4 mm	< 4.9 mm
6-1372442-8_Pos.1	> 3.75 mm	< 5.25 mm
6-1372442-8_Pos.2	> 4.05 mm	< 5.55 mm

THIS DRAWING IS A CONTROLLED DOCUMENT.

DIMENSIONS: mm	TOLERANCES UNLESS OTHERWISE SPECIFIED: 0 PLC ± 1 PLC ± 2 PLC ± 3 PLC ± 4 PLC ± ANGLES ± FINISH	DWN RIKON-Riedel 04MAY2012 CHK KURT L 15NOV2018 APVD SIEGERIED B 12DEC2018 PRODUCT SPEC APPLICATION SPEC WEIGHT CUSTOMER DRAWING	NAME UMBAUSATZ CONVERSION KIT SIZE A2 CAGE CODE 00779 DRAWING NO C-3-1372410-8 RESTRICTED TO SCALE 1:1 SHEET 1 OF 3 REV H
-------------------	---	--	--

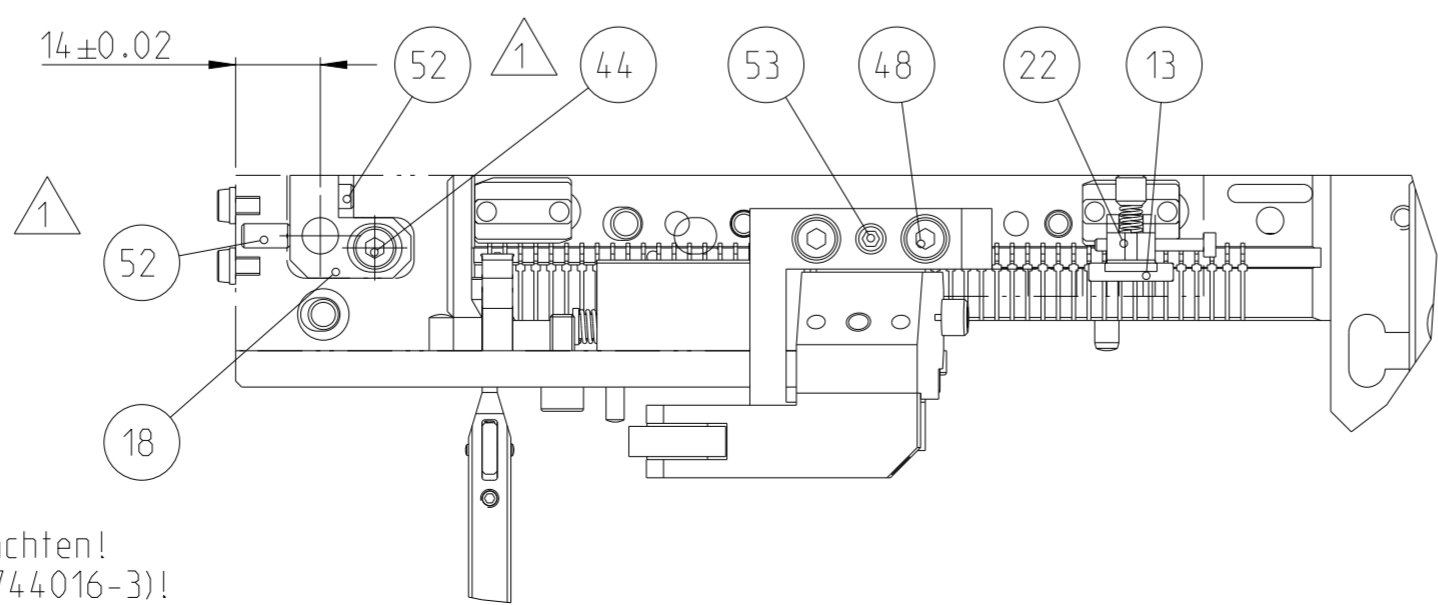

THIS DRAWING IS UNPUBLISHED. RELEASED FOR PUBLICATION 2012  
 © COPYRIGHT 2012 Tyco Electronics AMP GmbH ALL RIGHTS RESERVED.

REVISIONS				
P	LTR	DESCRIPTION	DATE	APVD
-	-	SEE SHEET 1	-	-

POS	QTY	TE/PN	PART REV	DESCRIPTION	WEAR	SPARE
1	1	3-1372415-5	D	SETZFINGER KOMPLETT INSERTION FINGER COMPLETE	YES	YES
2	1	8-1372442-2	H	SCHNITTPLATTE CUTTING PLATE	YES	YES
3	1	8-1372442-3	D	SCHNITTMESSER CUTTING BLADE	YES	YES
4	1	9-539939-3	D	VORSCHUBFINGER FEEDING FINGER	YES	YES
5	1	8-1372442-4	B	WERKZEUGBASIS TOOL BASE	-	-
6	1	6-1372442-3	C	Fuehrung vorne guiding in front	-	-
7	1	3-1372442-5	B	TRANSPORTSCHIEBER transport slider	-	-
8	1	1-1372562-7	A	Halter holder	-	-
9	1	5-1372234-3	B	Hebel lever	-	YES
10	1	8-1372418-6	B	Spliceerkennung innen recognition inside	-	-
11	1	8-1372418-7	B	Spliceerkennung aussen recognition outside	-	-
12	1	1372421-7	B	HEBEL LEVER	-	YES
13	1	2-1372269-9	C	BREMSE brake	-	YES
14	2	6-1372442-7	D	Einsatz insert	-	YES
15	2	6-1372442-8	C	Einsatz insert	-	YES
16	1	1372421-6	B	HALTER HOLDER	-	YES
17	1	8-1372234-3	B	Federaufnahme spring bolt	-	YES
18	1	2-1372481-2	A	ABSTIMMKLOTZ ADJUSTING BLOCK	-	YES
19	1	6-1372234-3	B	Achse axis	-	YES
20	1	2-1372386-6	B	DECKEL cover	-	-
21	1	6-1372561-6	C	ABSAUGKLOTZ SUCKING BLOCK	NO	NO
22	1	3-1372269-2	B	HEBEL lever	-	YES
23	1	6-539939-7	B	BOLZEN BOLT	-	YES
24	2	2-1372209-1	B	STIFT pin	-	YES
25	1	4-1372234-1	B	Halter holder	-	YES
26	1	1372562-8	A1	Duese Nozzle	-	-
27	1	5-1372498-9	B	ABFALLROHR WASTE PIPE	-	-
29	1	4-523159-7	A	INITIATOR PROXIMITY SWITCH	-	YES
30	1	2030564-1	A	CABLE, CONNECTING,METAL COUPLING, ANGLE -	-	YES
31	1	993083-4_0LD	A1	CONNECTOR,ELBOW ,90°,MINI -	-	YES
32	2	510974-1	A	CLAMP SCHLAUCHKLEMMEN	-	YES
33	1	2168799-1	A1	RING, SEALING -	-	YES
34	1	6-510500-5	A	Druckfeder PRESSURE SPRING	-	YES
35	1	9-510500-4	A	Druckfeder PRESSURE SPRING	-	YES
36	1	9-653860-9	A	Zugfeder TENSION SPRING	-	YES
37	1	9-653861-3	E	Druckfeder PRESSURE SPRING	-	YES
38	1	511591-8	A	KUGELDRUCKSCHRAUBE M6*16 -	-	YES
39	1	516403-1	A	FLOW ROLLER LAUFROLL	-	YES
40	1	506797-1	A	BOLT NORELEM: 02010-061	-	YES
41	1	3-656688-5	B	FUEHRUNGSBUCHSE GUIDE BUSHING	-	YES
42	1	3-656688-7	B	KUGELKAEFIG BALL BEARING CAGE	-	YES
43	4	2-519003-1_GATD_DKB	A	Zylinderschr. M3x5 DIN 84 -	-	-
44	5	2-519000-0_GATD_DKB	A2	Zylinderschr. M4x8 DIN 912 SCREW DIN EN ISO 4762	-	YES
45	3	2-519000-2_GATD_DKB	A2	Zylinderschr. M4x12 DIN 912 SCREW DIN EN ISO 4762	-	YES
46	2	2-519000-3	A	Zylinderschr. M4x16 DIN 912 -	-	YES

47	2	5-519072-3_GATD_DKB	A2	Zylinderschr. M4x18 DIN 912 SCREW DIN EN ISO 4762	-	YES
48	2	2-519000-5_GATD_DKB	A2	Zylinderschr. M4x25 DIN 912 SCREW DIN EN ISO 4762	-	YES
49	1	2-519000-7_GATD_DKB	A2	Zylinderschr. M4x35 DIN 912 SCREW DIN EN ISO 4762	-	YES
50	1	3-519000-4_GATD_DKB	A2	Zylinderschr. M5x25 DIN 912 SCREW DIN EN ISO 4762	-	YES
51	1	519072-1_GATD_DKB	A2	Zylinderschr. M5x70 DIN 912 SCREW DIN EN ISO 4762	-	YES
52	2	3-519011-0	B	SCREW M4x8 DIN 913 -	-	YES
53	1	3-519011-6	B	SCREW M5x6 DIN 913 -	-	YES
54	2	2-519011-8_GATD_DKB	A1	Gewindestift M4x5 DIN 913 -	-	YES
55	1	3-519011-5_EU_12APR12	B	Gewindestift M5x5 DIN 913 -	-	YES
56	2	3-519051-0_GATD_DKB	A	Zyl.-Stift 3m6x10 DIN 6325 pin 3m6x10 DIN 6325	-	-
57	2	3-519051-3_GATD_DKB	A	Zyl.-Stift 3m6x16 DIN 6325 pin 3m6x16 DIN 6325	-	-
58	1	3-519051-7	A	Zyl.-Stift 3m6x24 DIN 6325 -	-	YES
59	7	4-519051-6_GATD_DKB	A	Zyl.-Stift 4m6x10 DIN 6325 pin 4m6x10 DIN 6325	-	-
60	1	6-519051-3	A	Zyl.-Stift 5m6x12 DIN 6325 -	-	YES
61	2	8-519051-2_GATD_DKB	A	Zyl.-Stift 6m6x12 DIN 6325 pin 6m6x12 DIN 6325	-	-
62	4	519115-1_GATD_DKB	A	Passscheibe 3x6x1 DIN 988 -	-	-
63	2	519037-3	A	Passscheibe 5x10x0.5 DIN 988 -	-	YES
64	2	1-519115-0	A	Passscheibe 12x18x1 DIN 988 -	-	YES
65	1	519034-2_GATD_DKB	A2	Scheibe B 4.3 DIN 125 -St gal Ni -	-	YES

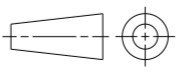
THIS DRAWING IS A CONTROLLED DOCUMENT.		DWN RIKON-Riedel 04MAY2012	 TE Connectivity	
DIMENSIONS: mm		CHK KURT L 15NOV2018		
TOLERANCES UNLESS OTHERWISE SPECIFIED:		APVD SIEGRIED B 12DEC2018	NAME UMBAUSATZ CONVERSION KIT	
		PRODUCT SPEC	SIZE	
MATERIAL		APPLICATION SPEC	CAGE CODE	DRAWING NO
FINISH		WEIGHT	A2100779	©-3-1372410-8
CUSTOMER DRAWING		SCALE 1:1	SHEET 2 OF 3	REV H

THIS DRAWING IS UNPUBLISHED. RELEASED FOR PUBLICATION 2012  
 © COPYRIGHT 2012 Tyco Electronics AMP GmbH ALL RIGHTS RESERVED.

REVISIONS					
P	LTR	DESCRIPTION	DATE	DWN	APVD
-		SEE SHEET 1	-	-	-

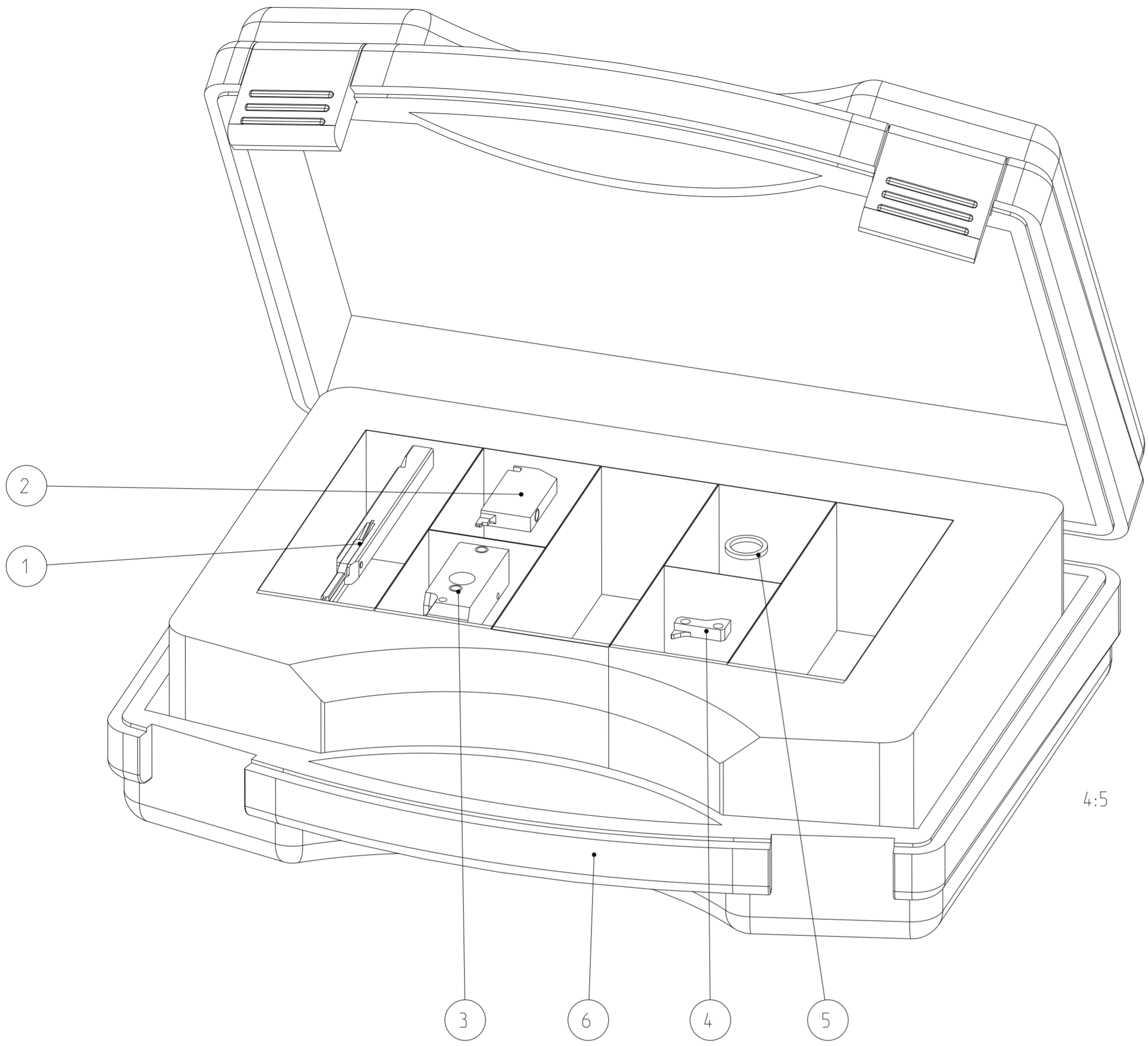

TOOL KIT 3-1372400-8 SHOWN

POS	QTY	TE/PN	PART REV	DESCRIPTION	WEAR	SPARE
1	1	3-1372415-5	D	SETZFINGER KOMPLETT INSERTION FINGER COMPLETE	YES	YES
2	1	8-1372442-3	D	SCHNITTMESSER CUTTING BLADE	YES	YES
3	1	8-1372442-2	H	SCHNITTPLATTE CUTTING PLATE	YES	YES
4	1	9-539939-3	D	VORSCHUBFINGER FEEDING FINGER	YES	YES
5	1	2168799-1	A1	RING, SEALING -	-	YES
6	1	539383-5	B	SUIT CASE ERSATZTEILKOFFER	-	-

THIS DRAWING IS A CONTROLLED DOCUMENT.		DWN RIKON-Riedel 04MAY2012	 TE Connectivity															
DIMENSIONS: mm		CHK KURT L 15NOV2018																
TOLERANCES UNLESS OTHERWISE SPECIFIED:		APVD SIEGERIED B 12DEC2018	NAME UMBAUSATZ CONVERSION KIT															
<table border="1"> <tr><td>0 PLC</td><td>±</td></tr> <tr><td>1 PLC</td><td>±</td></tr> <tr><td>2 PLC</td><td>±</td></tr> <tr><td>3 PLC</td><td>±</td></tr> <tr><td>4 PLC</td><td>±</td></tr> <tr><td>ANGLES</td><td>±</td></tr> <tr><td>FINISH</td><td>±</td></tr> </table>		0 PLC	±	1 PLC	±	2 PLC	±	3 PLC	±	4 PLC	±	ANGLES	±	FINISH	±	PRODUCT SPEC	SIZE A2	
0 PLC	±																	
1 PLC	±																	
2 PLC	±																	
3 PLC	±																	
4 PLC	±																	
ANGLES	±																	
FINISH	±																	
MATERIAL		APPLICATION SPEC	CAGE CODE 00779	DRAWING NO 3-1372410-8														
		WEIGHT	RESTRICTED TO															
		CUSTOMER DRAWING	SCALE 1:1	SHEET 3 OF 3														
			REV H															