

recommended PCB-layout
(5:1)

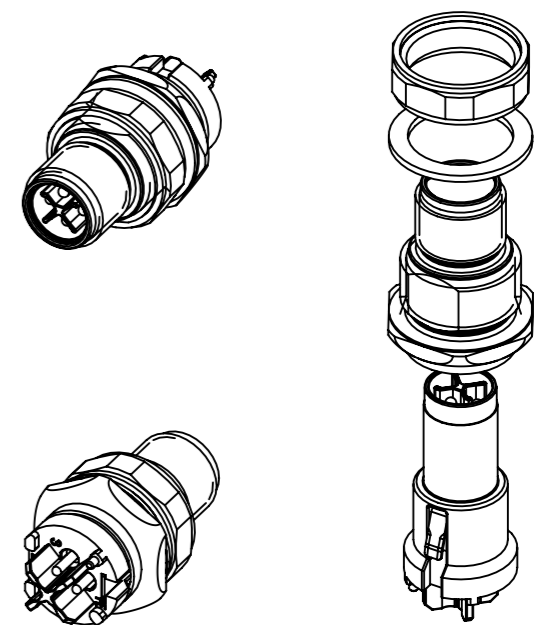

- recommended PCB: 1.6mm
- recommended torque for the lock nut: 2.0Nm
- 1 pcs. single package

	All rights reserved	Created by 402918	Inspected by MICLAUS	Standardisation ROEBEN	Date 2021-12-06	State Final Release	Ref. Sub.
	Department EL PD	Title M12-PCB-THR-2PC-4P-SCOD-M-STR-SHLD				Doc-Key / ECM-Nr. 100799935/UGD/004/D 50000207442	
HARTING D-32339 Espelkamp		Type TB	Number 21033091430		Rev. D	Page 1/2	

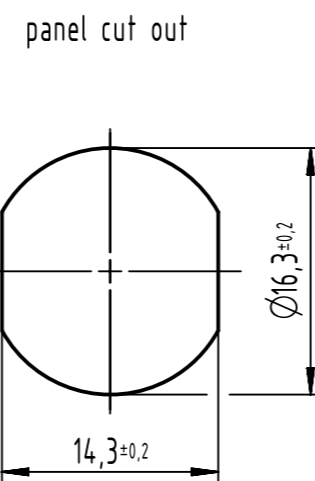
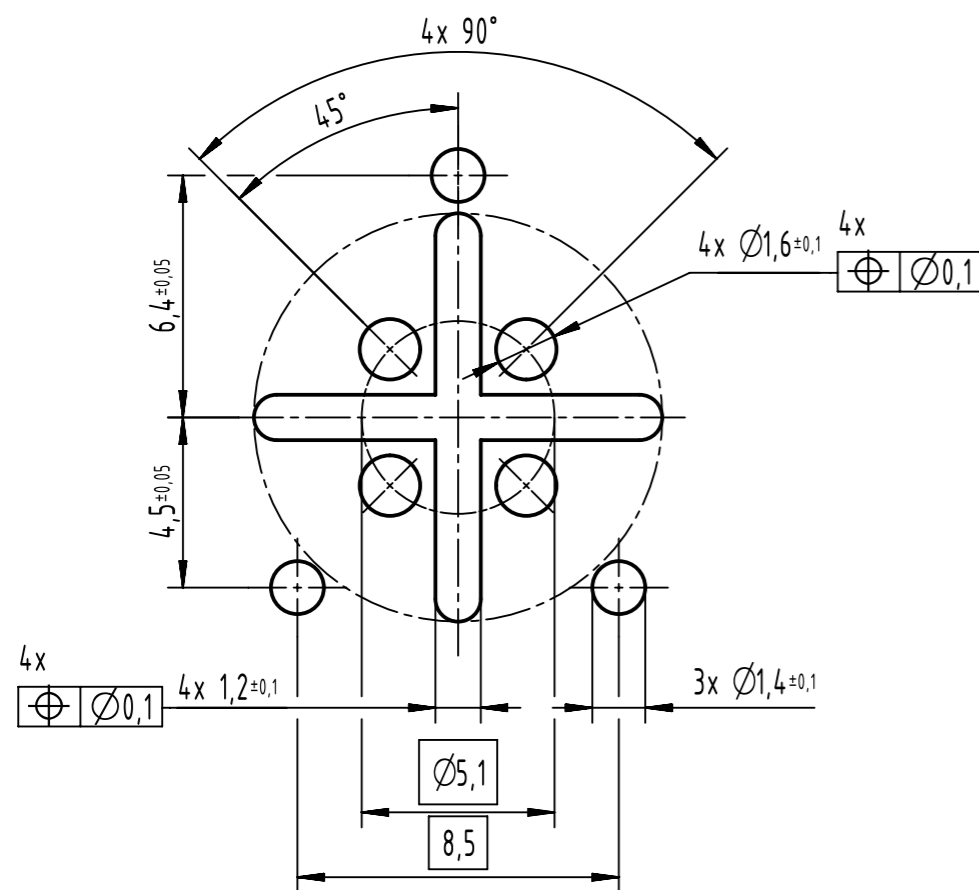
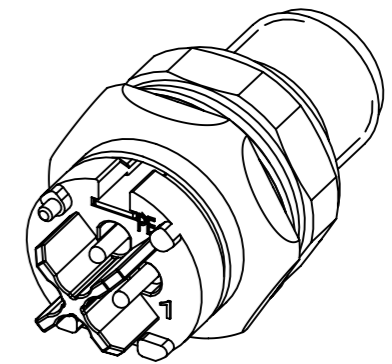
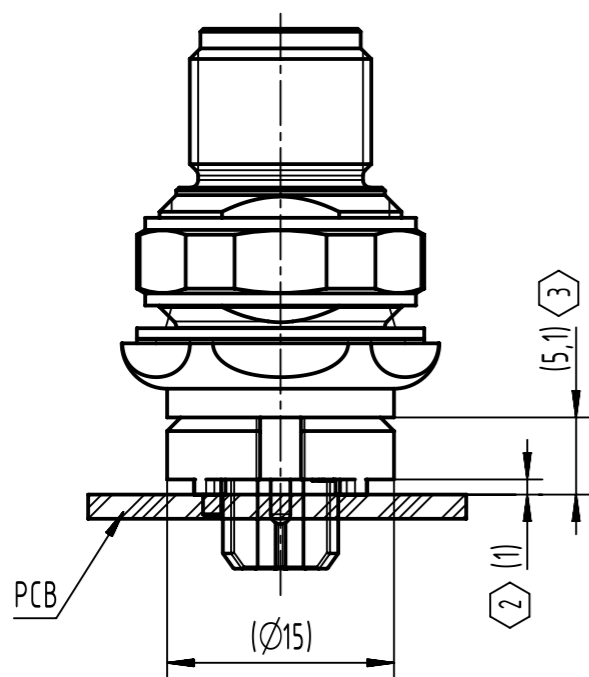
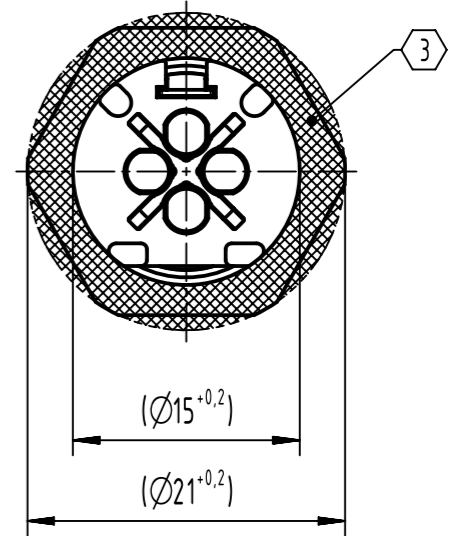
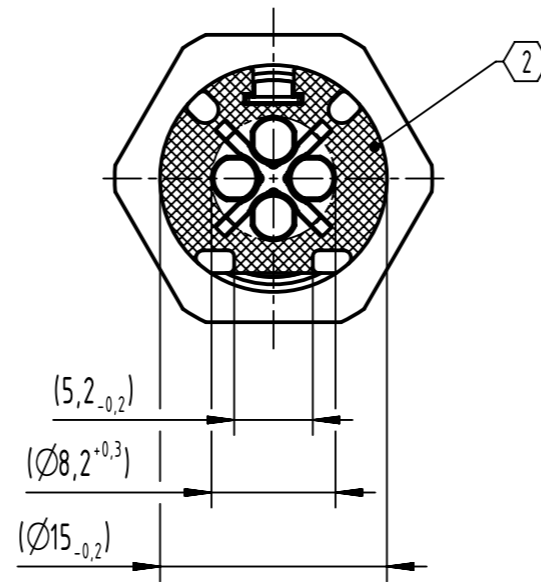
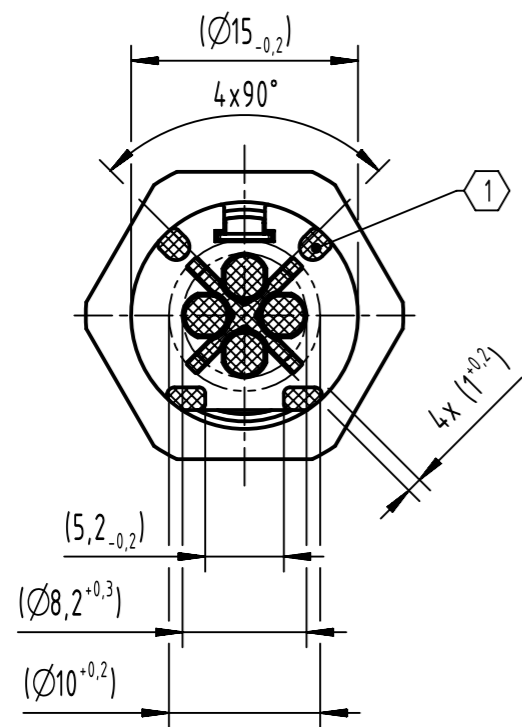

- ① the area where no component on the PCB is allowed
- ② the area where components of max. 0.9mm height are allowed on the PCB
- ③ starting from $\varnothing 15^{+0,2}$, the maximum height of the components on the PCB is 6,7mm

	All rights reserved Department EL PD	Created by 402918	Inspected by MICLAUS	Standardisation ROEBEN	Date 2021-12-06	State Final Release	Ref. Sub.
	Title M12-PCB-THR-2PC-4P-SCOD-M-STR-SHLD					Doc-Key / ECM-Nr. 100799935/UGD/004/D 500000207442	
HARTING D-32339 Espelkamp		Type TB	Number 21033091430		Rev. D	Page 2/2	