

REVISIONS					
P	LTR	DESCRIPTION	DATE	DMN	APVD
F	REV PER ECO	17-006927	6-16-17	CT	DM

1. THIS RCPT. IS DESIGN TO CONFORM TO THE LATEST ISSUE OF MIL-DTL-24308.
2. MAX WIRE INSULATION TO BE USED WITH THIS RCPT IS .054 [1.37] DIA.
3. METAL RETENTION CLIPS AREA INCLUDED IN INSERTS.
4. UL/CSA DESIGNATION STAMPED ON SHELL.
5. EPOXY IS APPLIED BETWEEN FRONT AND REAR SHELLS AND INSERTS.
6. NO GROMMET, CONTACTS, OR TOOL INCLUDED
7. NO GROMMET INCLUDED
8. NO INS/EXT TOOL INCLUDED
9. NO INS/EXT TOOL OR CONTACTS INCLUDED

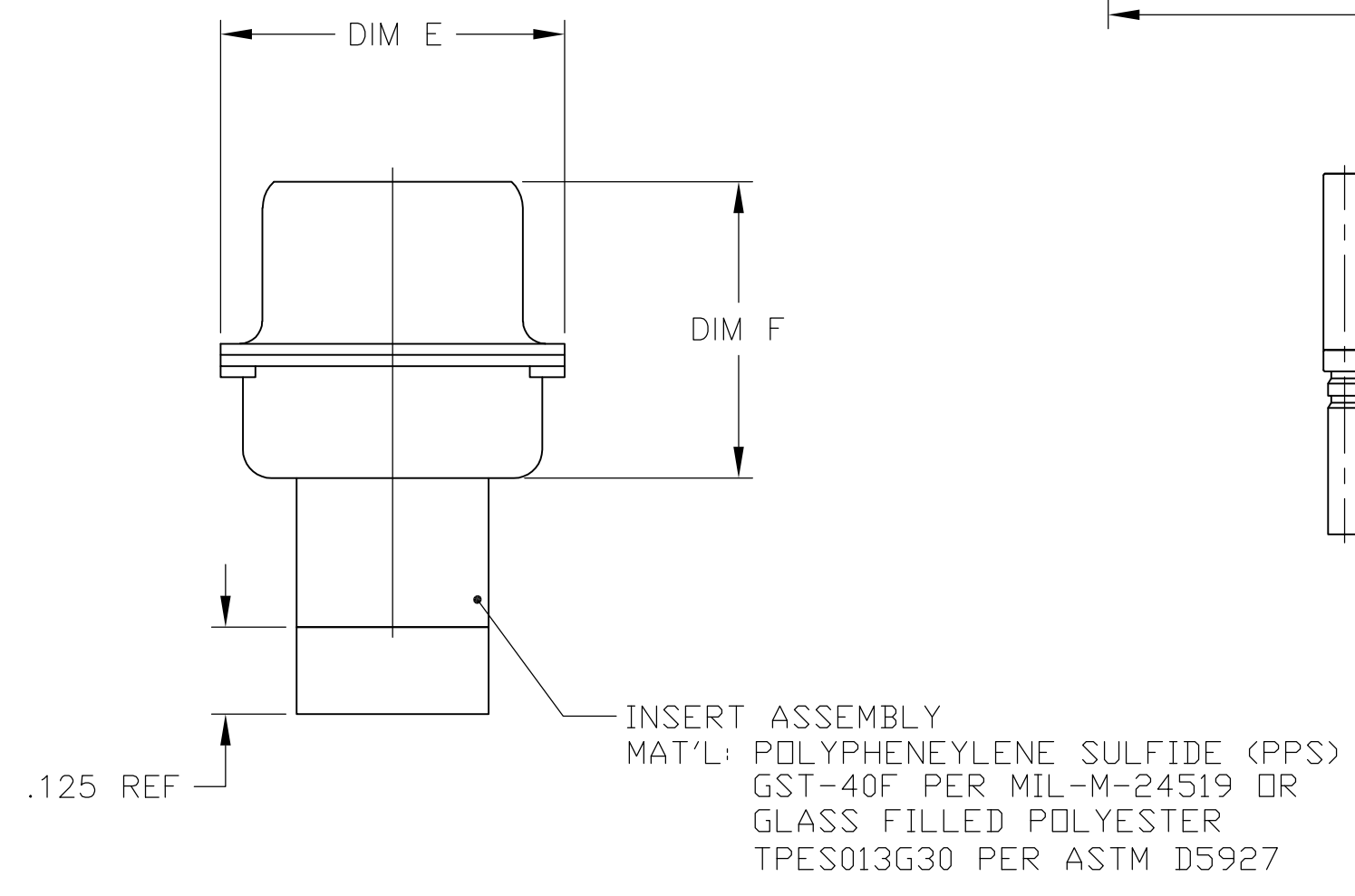

REMARKS	MARKED TE PART NUMBER	L	J	H	G	F	E	D	C	B	A	INSERT ARRANGEMENT	NO OF POS	SHELL SIZE	PART NUMBER
7	4-2221760-1	.040 [1.02] .020 [0.51]	.432 [10.97] .412 [10.46]	.769 [19.53] .749 [19.02]	.248 [6.30] .238 [5.82]	.439 [11.15] .419 [10.64]	.509 [12.93] .479 [12.17]	.316 [8.03] .306 [7.77]	.989 [25.12] .979 [24.87]	.648 [16.46] .638 [16.21]	1.228 [31.19] 1.198 [30.43]	MS18273-2	15	1	4-2221760-1
6	3-2221760-1	.040 [1.02] .020 [0.51]	.432 [10.97] .412 [10.46]	.769 [19.53] .749 [19.02]	.248 [6.30] .238 [5.82]	.439 [11.15] .419 [10.64]	.509 [12.93] .479 [12.17]	.316 [8.03] .306 [7.77]	.989 [25.12] .979 [24.87]	.648 [16.46] .638 [16.21]	1.228 [31.19] 1.198 [30.43]	MS18273-2	15	1	3-2221760-1
9	1-2221760-6	.049 [1.24] .029 [0.74]	.606 [15.39] .586 [14.88]	3.312 [58.72] 2.292 [58.22]	.248 [6.30] .238 [5.82]	.439 [11.15] .419 [10.64]	.683 [17.35] .653 [16.59]	.490 [12.45] .480 [12.19]	2.505 [63.63] 2.495 [63.37]	2.194 [55.72] 2.184 [55.47]	2.744 [69.70] 2.714 [68.93]	MS14004-1	104	6	1-2221760-6
9	1-2221760-5	.049 [1.24] .029 [0.74]	.544 [13.82] .524 [13.31]	2.188 [55.58] 2.168 [55.07]	.248 [6.30] .238 [5.82]	.439 [11.15] .419 [10.64]	.620 [15.75] .590 [14.99]	.428 [10.87] .418 [10.62]	2.411 [61.24] 2.401 [60.99]	2.069 [52.55] 2.059 [52.30]	2.650 [67.31] 2.620 [66.55]	MS18277-2	78	5	1-2221760-5
9	1-2221760-4	.049 [1.24] .029 [0.74]	.432 [10.97] .412 [10.46]	2.282 [57.96] 2.262 [57.45]	.248 [6.30] .238 [5.82]	.439 [11.15] .419 [10.64]	.509 [12.93] .479 [12.17]	.316 [8.03] .306 [7.77]	2.505 [63.63] 2.495 [63.37]	2.164 [54.97] 2.154 [54.71]	2.744 [69.70] 2.714 [68.94]	MS18276-2	62	4	1-2221760-4
9	1-2221760-3	.049 [1.24] .029 [0.74]	.432 [10.97] .412 [10.46]	1.635 [41.53] 1.615 [41.02]	.248 [6.30] .238 [5.82]	.439 [11.15] .419 [10.64]	.509 [12.93] .479 [12.17]	.316 [8.03] .306 [7.77]	1.857 [47.17] 1.847 [46.91]	1.516 [38.51] 1.506 [38.25]	2.103 [53.42] 2.073 [52.65]	MS18275-2	44	3	1-2221760-3
9	1-2221760-2	.040 [1.02] .020 [0.51]	.432 [10.97] .412 [10.46]	1.093 [27.76] 1.073 [27.25]	.248 [6.30] .238 [5.82]	.439 [11.15] .419 [10.64]	.509 [12.93] .479 [12.17]	.316 [8.03] .306 [7.77]	1.317 [33.45] 1.307 [33.20]	.976 [24.79] .966 [24.54]	1.556 [39.52] 1.526 [38.76]	MS18274-2	26	2	1-2221760-2
9	1-2221760-1	.040 [1.02] .020 [0.51]	.432 [10.97] .412 [10.46]	.769 [19.53] .749 [19.02]	.248 [6.30] .238 [5.82]	.439 [11.15] .419 [10.64]	.509 [12.93] .479 [12.17]	.316 [8.03] .306 [7.77]	.989 [25.12] .979 [24.87]	.648 [16.46] .638 [16.21]	1.228 [31.19] 1.198 [30.43]	MS18273-2	15	1	1-2221760-1
8	2221760-6	.049 [1.24] .029 [0.74]	.606 [15.39] .586 [14.88]	3.312 [58.72] 2.292 [58.22]	.248 [6.30] .238 [5.82]	.439 [11.15] .419 [10.64]	.683 [17.35] .653 [16.59]	.490 [12.45] .480 [12.19]	2.505 [63.63] 2.495 [63.37]	2.194 [55.72] 2.184 [55.47]	2.744 [69.70] 2.714 [68.93]	MS14004-1	104	6	2221760-6
8	2221760-5	.049 [1.24] .029 [0.74]	.544 [13.82] .524 [13.31]	2.188 [55.58] 2.168 [55.07]	.248 [6.30] .238 [5.82]	.439 [11.15] .419 [10.64]	.620 [15.75] .590 [14.99]	.428 [10.87] .418 [10.62]	2.411 [61.24] 2.401 [60.99]	2.069 [52.55] 2.059 [52.30]	2.650 [67.31] 2.620 [66.55]	MS18277-2	78	5	2221760-5
8	2221760-4	.049 [1.24] .029 [0.74]	.432 [10.97] .412 [10.46]	2.282 [57.96] 2.262 [57.45]	.248 [6.30] .238 [5.82]	.439 [11.15] .419 [10.64]	.509 [12.93] .479 [12.17]	.316 [8.03] .306 [7.77]	2.505 [63.63] 2.495 [63.37]	2.164 [54.97] 2.154 [54.71]	2.744 [69.70] 2.714 [68.94]	MS18276-2	62	4	2221760-4
8	2221760-3	.049 [1.24] .029 [0.74]	.432 [10.97] .412 [10.46]	1.635 [41.53] 1.615 [41.02]	.248 [6.30] .238 [5.82]	.439 [11.15] .419 [10.64]	.509 [12.93] .479 [12.17]	.316 [8.03] .306 [7.77]	1.857 [47.17] 1.847 [46.91]	1.516 [38.51] 1.506 [38.25]	2.103 [53.42] 2.073 [52.65]	MS18275-2	44	3	2221760-3
8	2221760-2	.040 [1.02] .020 [0.51]	.432 [10.97] .412 [10.46]	1.093 [27.76] 1.073 [27.25]	.248 [6.30] .238 [5.82]	.439 [11.15] .419 [10.64]	.509 [12.93] .479 [12.17]	.316 [8.03] .306 [7.77]	1.317 [33.45] 1.307 [33.20]	.976 [24.79] .966 [24.54]	1.556 [39.52] 1.526 [38.76]	MS18274-2	26	2	2221760-2
8	2221760-1	.040 [1.02] .020 [0.51]	.432 [10.97] .412 [10.46]	.769 [19.53] .749 [19.02]	.248 [6.30] .238 [5.82]	.439 [11.15] .419 [10.64]	.509 [12.93] .479 [12.17]	.316 [8.03] .306 [7.77]	.989 [25.12] .979 [24.87]	.648 [16.46] .638 [16.21]	1.228 [31.19] 1.198 [30.43]	MS18273-2	15	1	2221760-1

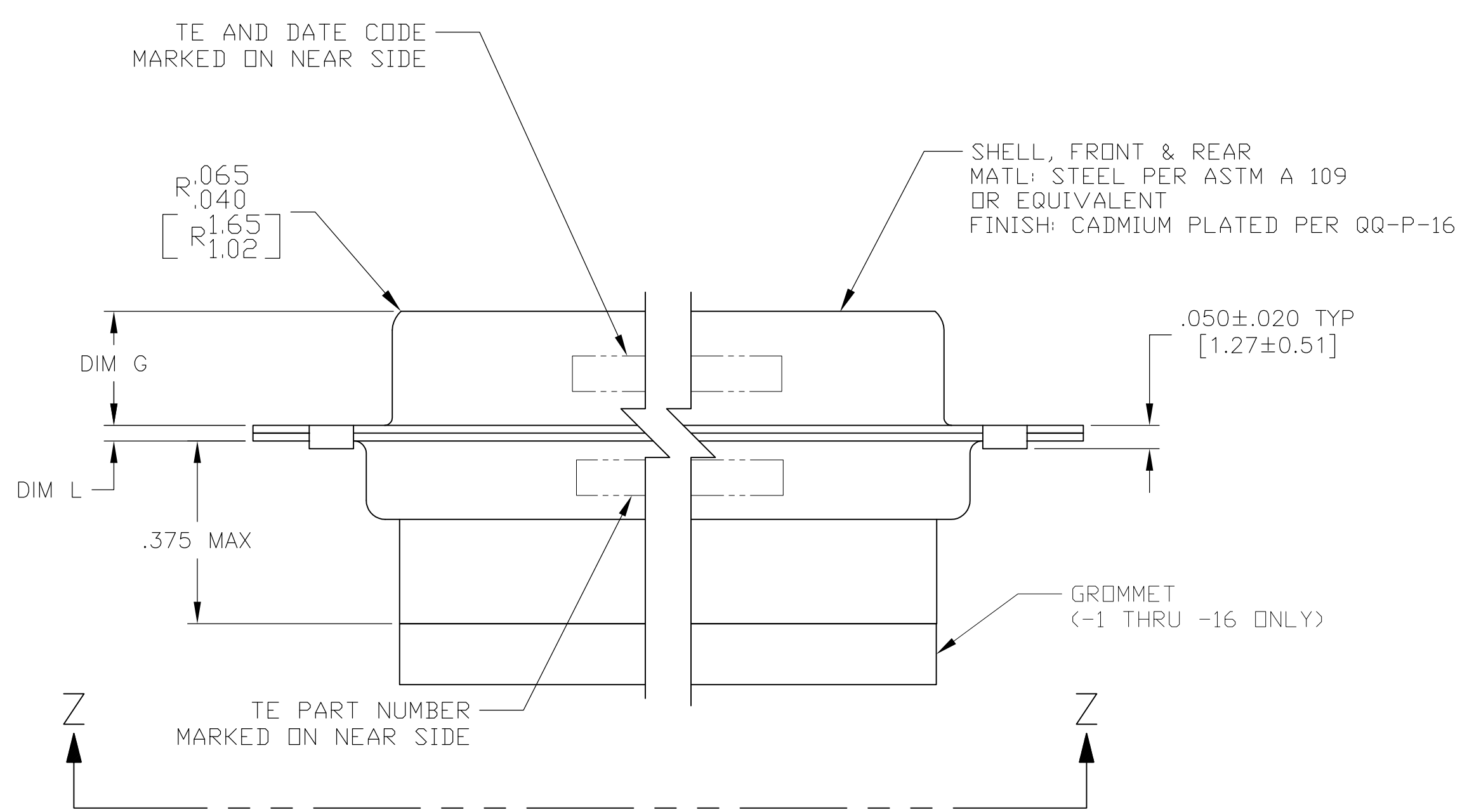
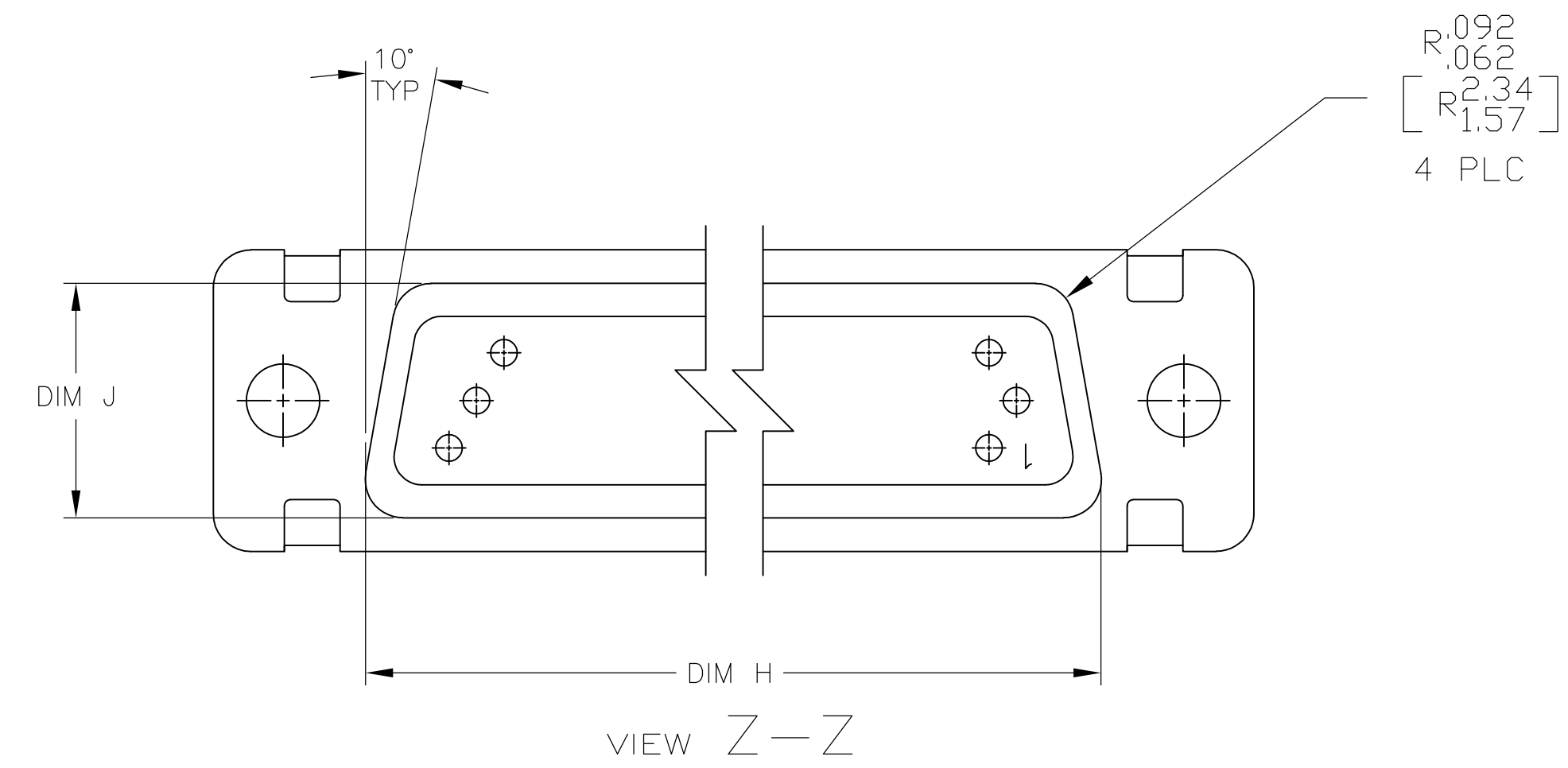
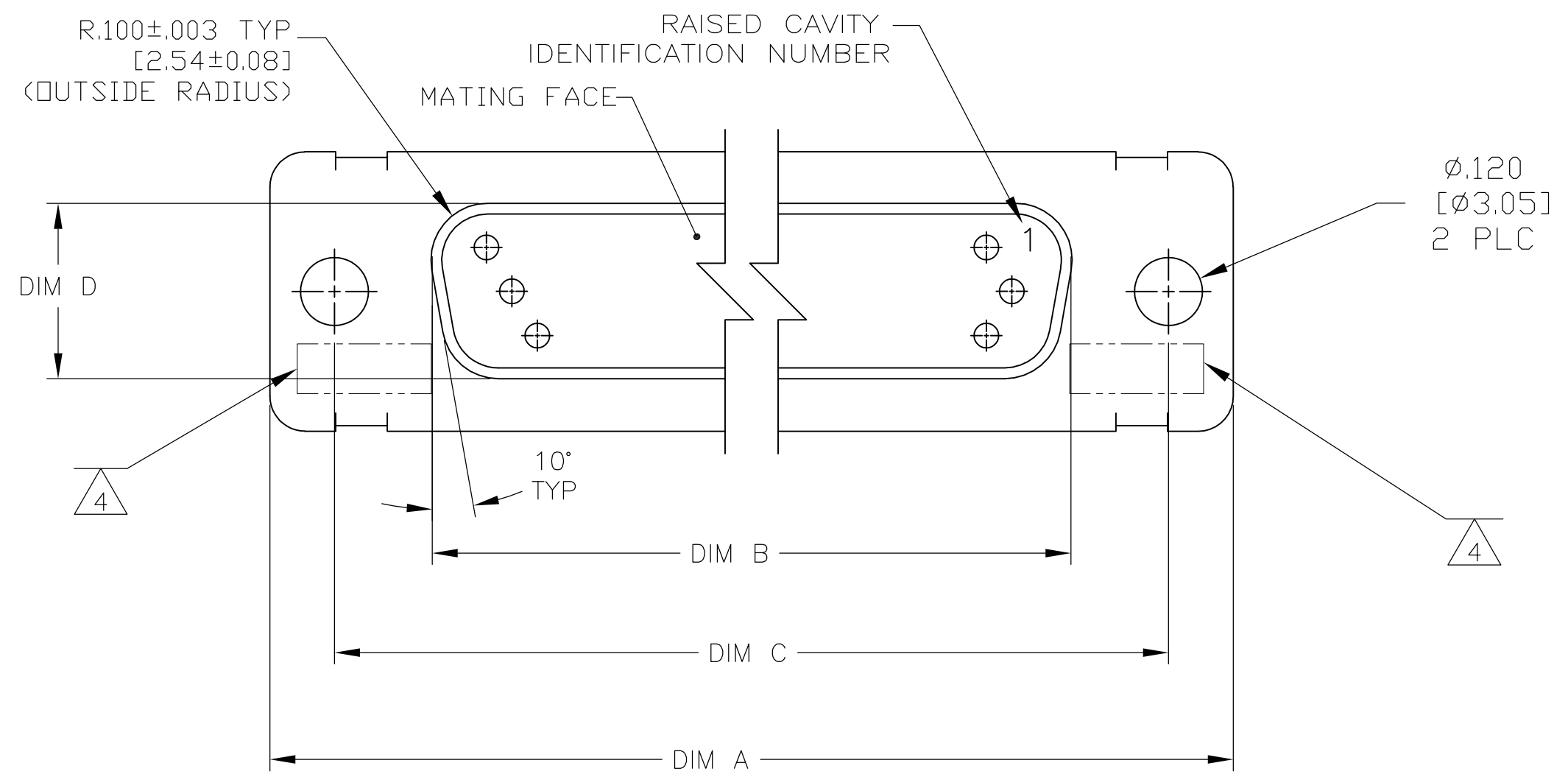
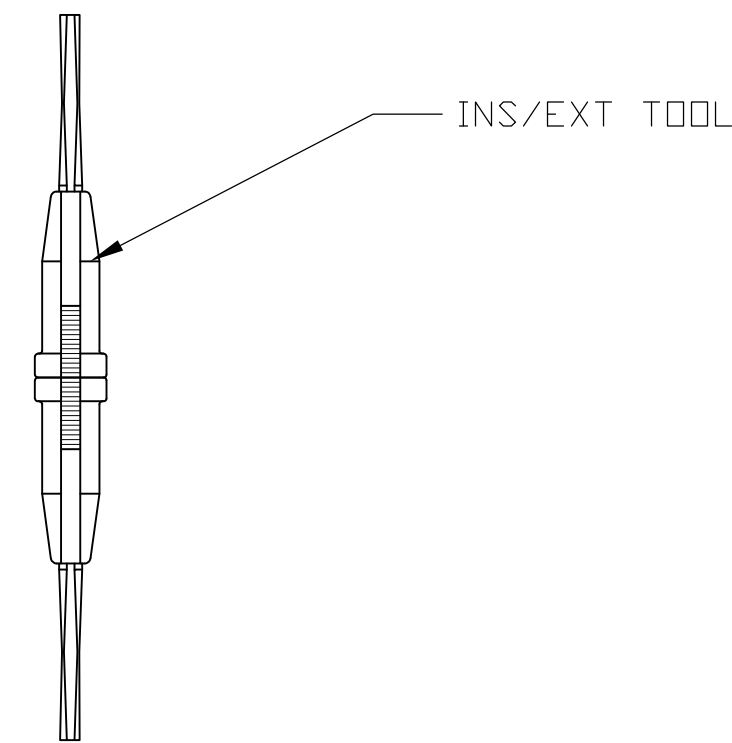

SCALE 1:1

THIS DRAWING IS A CONTROLLED DOCUMENT.

DIMENSIONS: INCHES	TOLERANCES UNLESS OTHERWISE SPECIFIED:	DIN 8-20-14	8-20-14
0 PLC ± -	1 PLC ± -	C.C. THOMAS	C.C. THOMAS
2 PLC ± -	3 PLC ± .005 [0.13]	C. DERRICK	C. DERRICK
4 PLC ± -	ANGLES ± -	C. DERRICK	C. DERRICK
MATERIAL SEE CALLOUTS	FINISH SEE CALLOUTS	APPROVED	NAME
		000779	RCPT ASSY, AMPLIMITE KIT, IP67 SIZE 1 THRU 5, SERIES 90
WEIGHT 0.000000	SIZE A1	CAGE CODE 00779	DRAWING NO. 2221760
CUSTOMER DRAWING	SCALE 4:1	SHEET 1 of 1	REV F