

P	LTR	DESCRIPTION	DATE	DWN	APVD
	R	REVISED PER ECR-21-102050	14APR2021	M. J	E. I

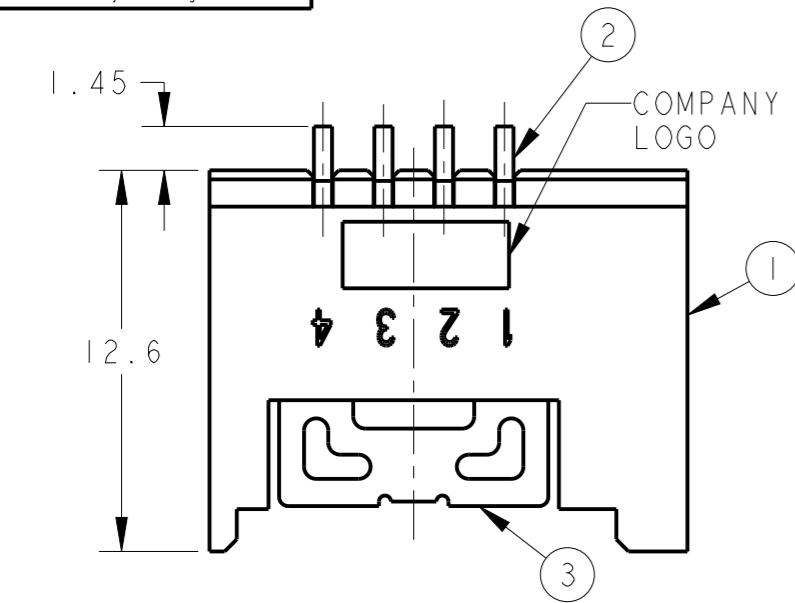

1 MATERIAL & FINISH
 CONTACT: COPPER ALLOY, UNDER Ni PLATING 1.27umMIN
 CONTACT AREA: Au PLATING 0.2umMIN
 TINE AREA: TIN PLATING 1~3um
 HOUSING: THERMO PLASTIC
 SOLDER PEG; COPPER ALLOY, UNDER Ni PLATING 1.27umMIN
 TINE AREA: TIN PLATING 1~3um
 2 COPLANARITY OF CONTACT AND SOLDER PEG: 0.1mm MAX.

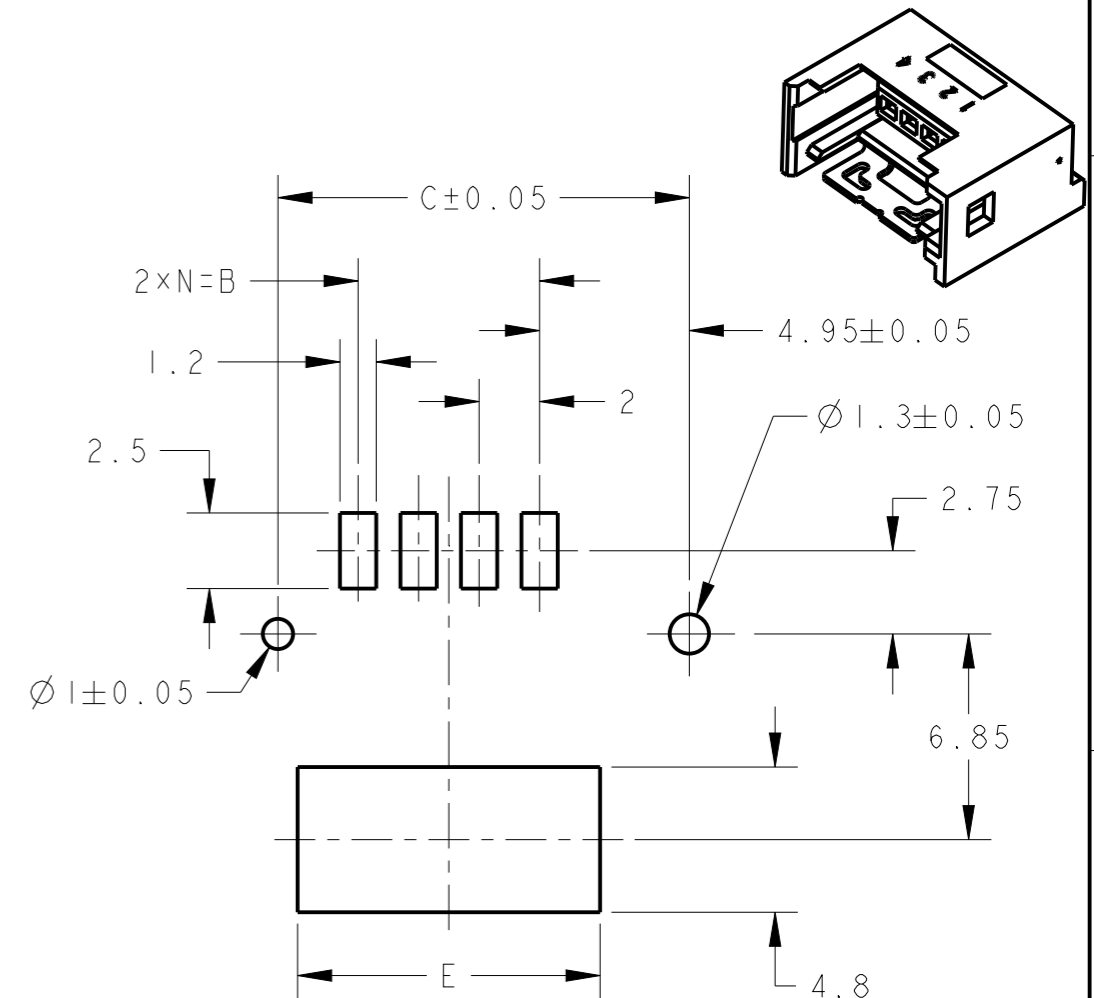
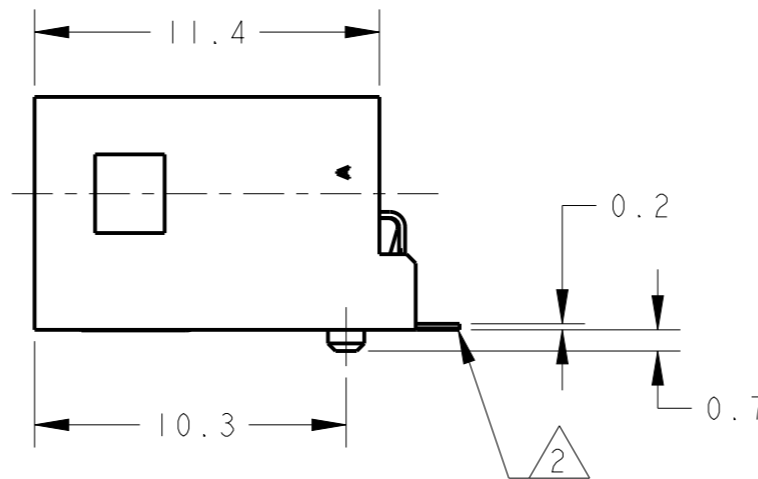
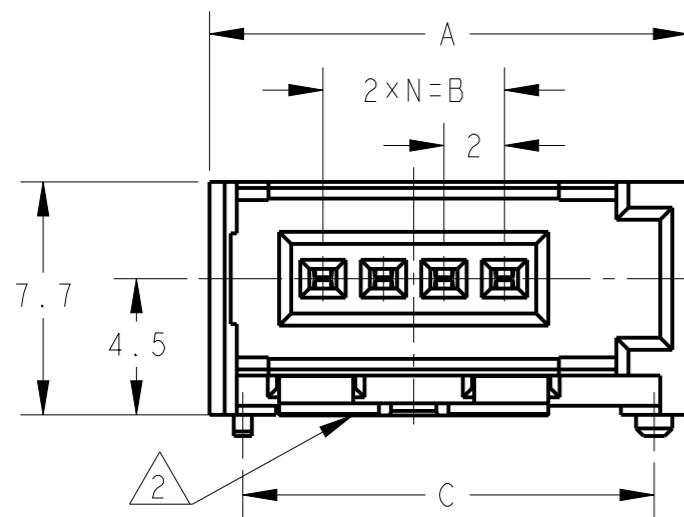

REFERENCE DIMENSION OF PCB(MOUNTING SIDE)

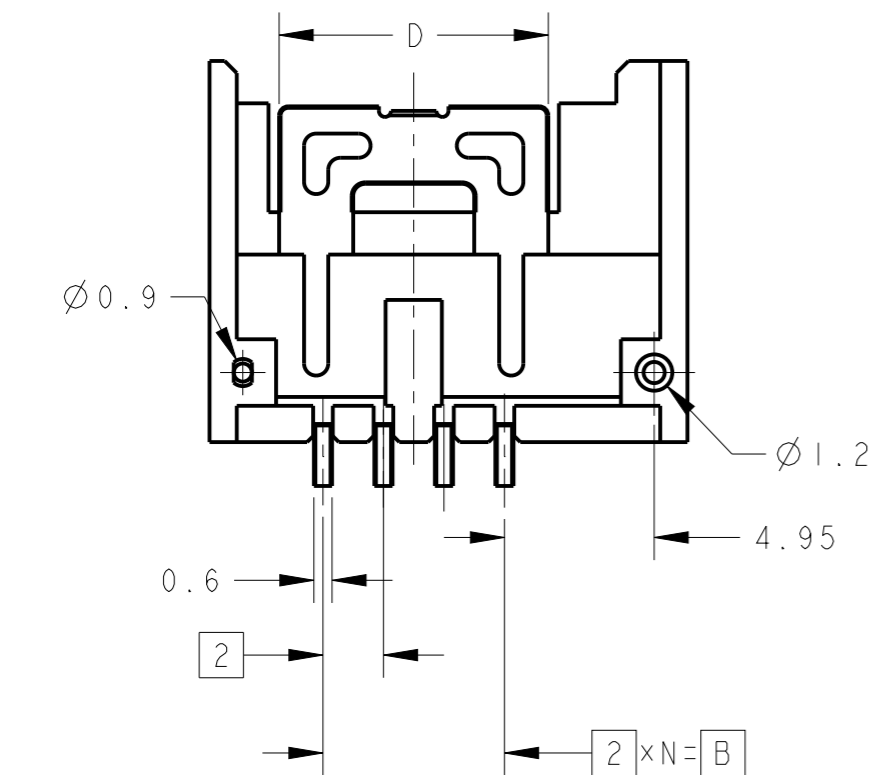

1565994-3, 4: AS SHOWN

1.1g	0.95g	1.1g	0.95g																		
1	1	1	1	SOLDER PEG																	3
4	3	4	3	HDR CONTACT																	2
1				HSR HSG, 4P, W/O BOSS	10	8.9	-	6	15.8	3	4	1									
	1			HDR HSG, 3P, W/O BOSS	8	6.9	-	4	13.8	2	3	1									
		1		HDR HSG, 4P, WITH BOSS	10	8.9	13.6	6	15.8	3	4	1									
			1	HDR HSG, 3P, WITH BOSS	8	6.9	11.6	4	13.8	2	3	1									
1	-4	1	-3	-4	-3	NAME	E	D	C	B	A	N	POS	ITEM							

THIS DRAWING IS A CONTROLLED DOCUMENT.

DWN M. Kimura 18APR2002
 CHK Y. KASHIWA 18APR2002
 APVD Y. KASHIWA 18APR2002

TE TE Connectivity
 NAME HDR ASSEMBLY, RIGHT ANGLE SMT TYPE RITS CONNECTOR

PRODUCT SPEC	108-5765	SIZE	A3	CAGE CODE		DRAWING NO	C=1565994	RESTRICTED TO	
APPLICATION SPEC		WEIGHT	TABLE	SCALE	4:1	SHEET	1 OF 3	REV	R

DIMENSIONS: mm
 TOLERANCES UNLESS OTHERWISE SPECIFIED: ±0.25
 0 PLC ±
 1 PLC ±0.1
 2 PLC ±0.01
 3 PLC ±0.001
 4 PLC ±0.0001
 ANGLES ±3°
 MATERIAL SEE NOTE FINISH SEE NOTE

CUSTOMER DRAWING

P	LTR	DESCRIPTION	DATE	DWN	APVD
-	-	SEE SHEET 1	-	-	-

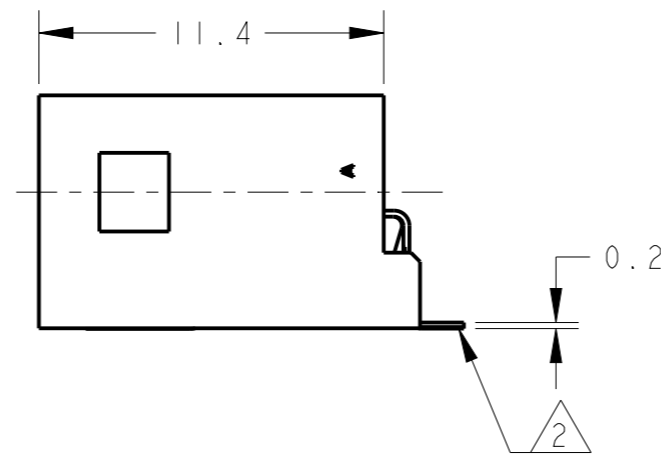
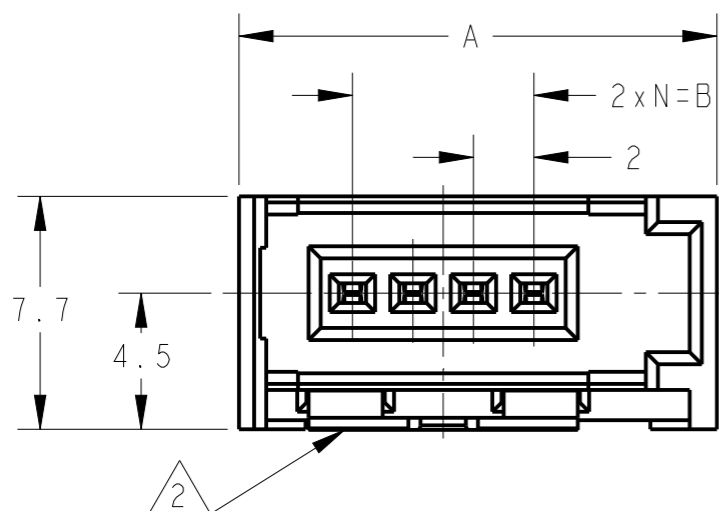
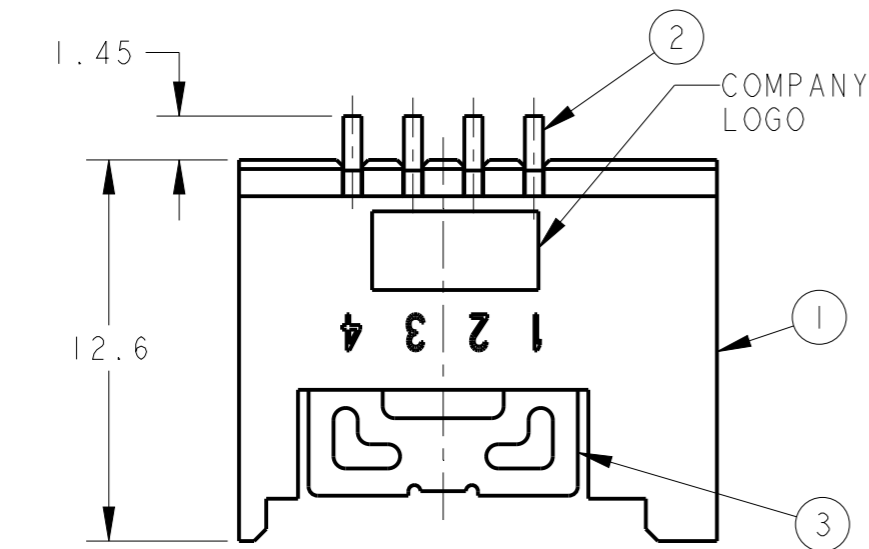

1-1565994-3, 4: AS SHOWN

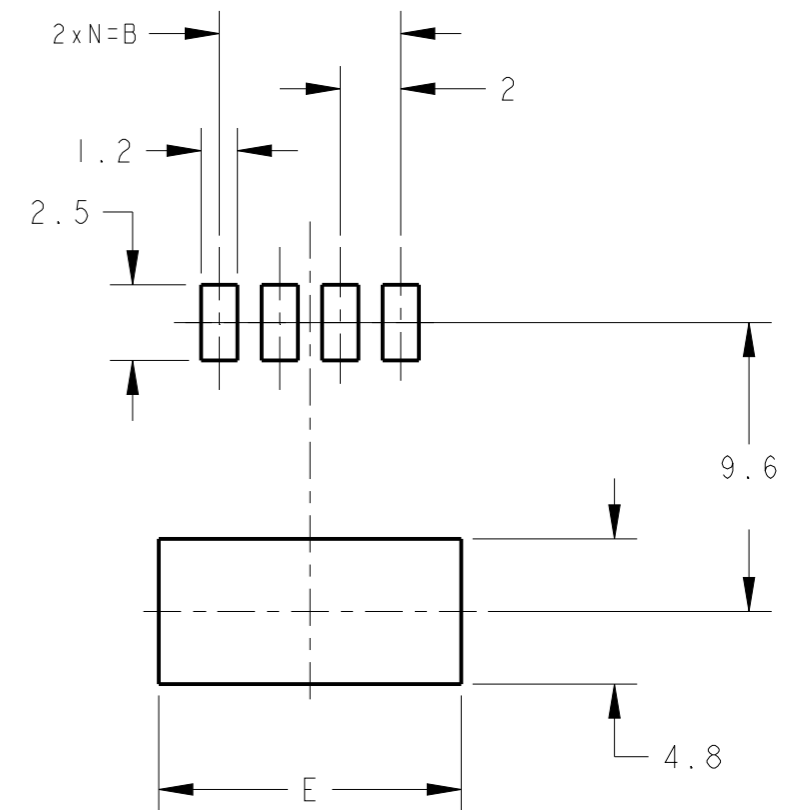

REFERENCE DIMENSION OF PCB(MOUNTING SIDE)

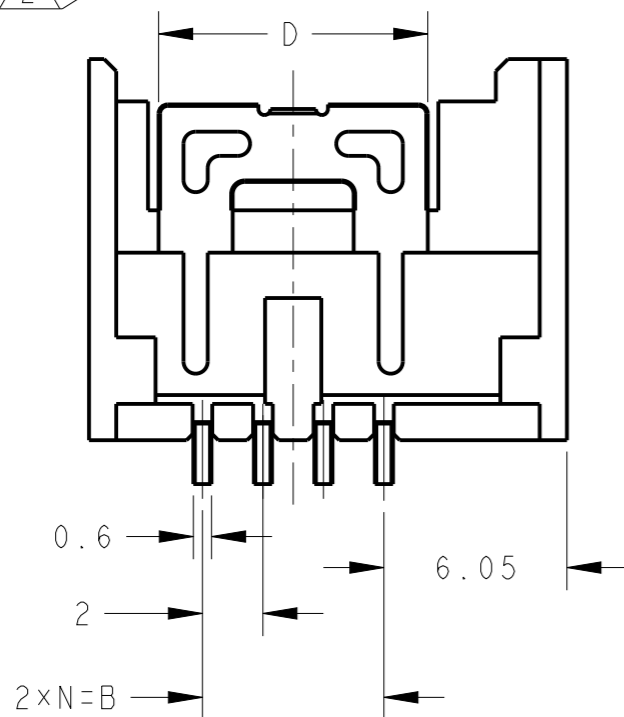

THIS DRAWING IS A CONTROLLED DOCUMENT.		DWN M. Kimura 18APR2002			
DIMENSIONS: mm		CHK Y. KASHIWA 18APR2002			
TOLERANCES UNLESS OTHERWISE SPECIFIED: ±0.25		APVD Y. KASHIWA 18APR2002	NAME HDR ASSEMBLY, RIGHT ANGLE SMT TYPE RITS CONNECTOR		
0 PLC ± 1 PLC ±0.1 2 PLC ±0.01 3 PLC ±0.001 4 PLC ±0.0001 ANGLES ±3°		PRODUCT SPEC 108-5765	SIZE A3	CAGE CODE C-1565994	RESTRICTED TO -
MATERIAL SEE SHEET 1	FINISH SEE SHEET 1	APPLICATION SPEC -	WEIGHT TABLE	SCALE 4:1	SHEET 2 OF 3
CUSTOMER DRAWING		REV R			

P	LTR	DESCRIPTION	DATE	DWN	APVD
-		SEE SHEET 1	-	-	-

PACKING STYLE

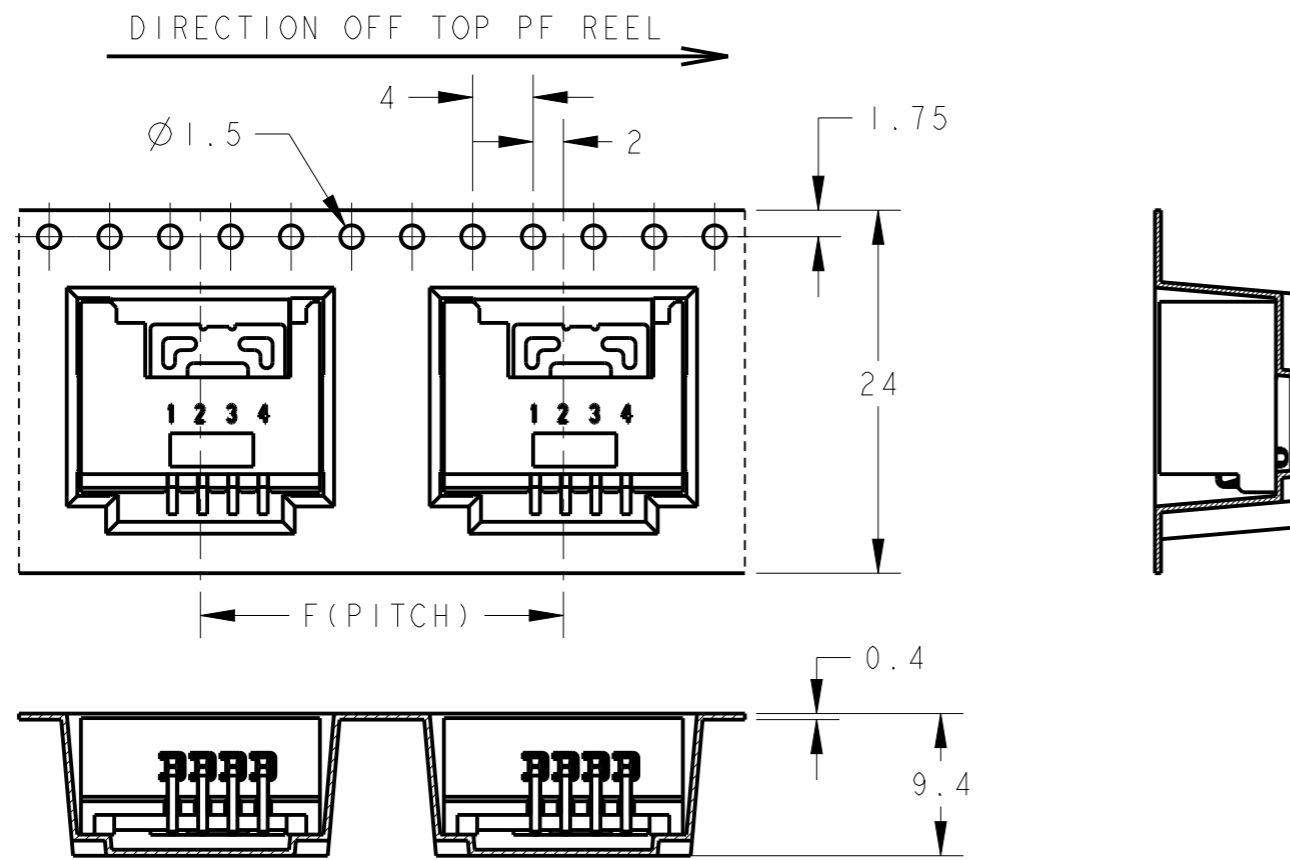

WEEDING THE COVER TAPE AROUND THE OUTER PERIPHERY IN A TURN.

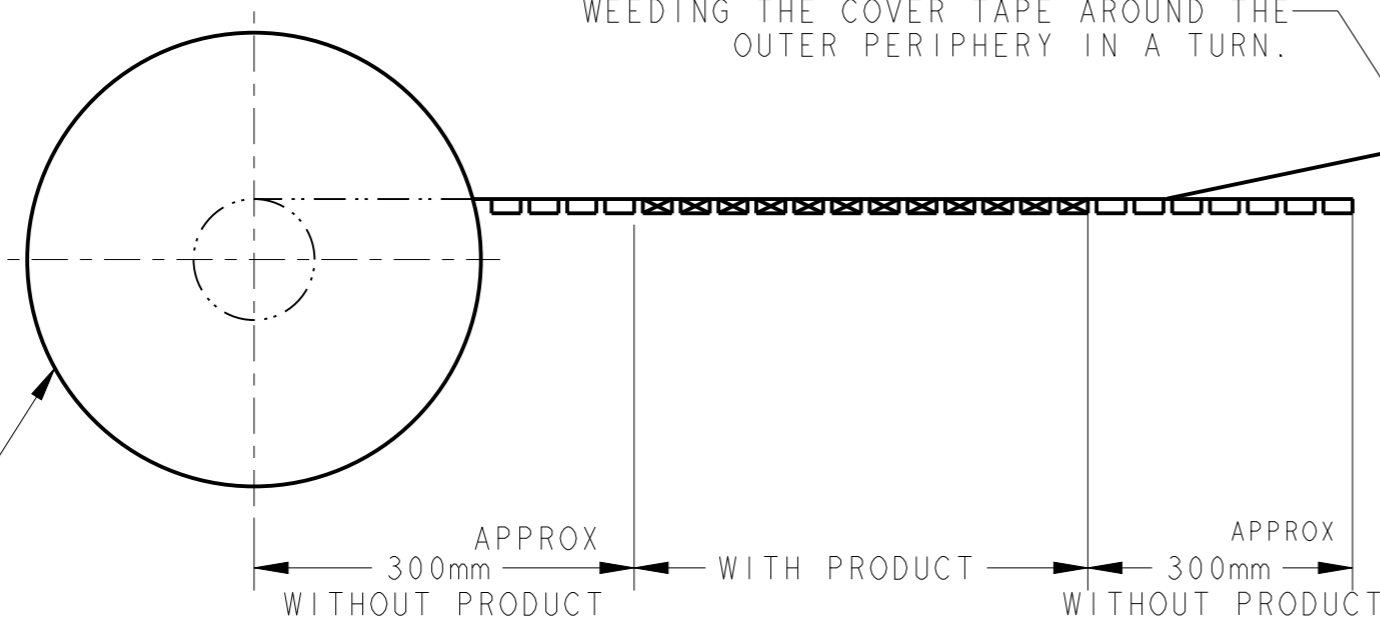

200	4	24	1-1565994-4
250	3	20	1-1565994-3
200	4	24	1565994-4
250	3	20	1565994-3
QTY	POS	F	PART NO.

REEL SIZE:
330DIAx80DIA(HUB)x31.5W(25.5W INSIDE)

THIS DRAWING IS A CONTROLLED DOCUMENT.		DWN M. Kimura 18APR2002	TE Connectivity	
DIMENSIONS: mm		CHK Y. KASHIWA 18APR2002		
TOLERANCES UNLESS OTHERWISE SPECIFIED: ± 0.3		APVD Y. KASHIWA 18APR2002	NAME HDR ASSEMBLY, RIGHT ANGLE SMT TYPE RITS CONNECTOR	
<ul style="list-style-type: none"> 0 PLC \pm 1 PLC ± 0.1 2 PLC ± 0.01 3 PLC ± 0.001 4 PLC ± 0.0001 ANGLES $\pm 3^\circ$ 		PRODUCT SPEC -	RESTRICTED TO -	
MATERIAL SEE SHEET 1		FINISH SEE SHEET 1	APPLICATION SPEC -	SCALE NONE
MATERIAL SEE SHEET 1		FINISH SEE SHEET 1	WEIGHT TABLE	SIZE A3
MATERIAL SEE SHEET 1		FINISH SEE SHEET 1	WEIGHT TABLE	DRAWING NO C-1565994
MATERIAL SEE SHEET 1		FINISH SEE SHEET 1	WEIGHT TABLE	SHEET 3 OF 3
MATERIAL SEE SHEET 1		FINISH SEE SHEET 1	WEIGHT TABLE	REV R