

# Converter - Brake - Inverter Module (CBI2) with Trench IGBT technology

Preliminary data

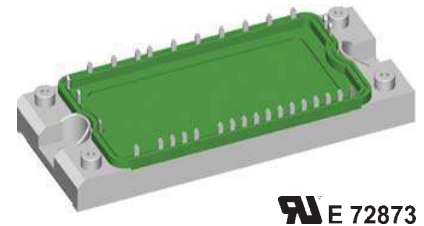
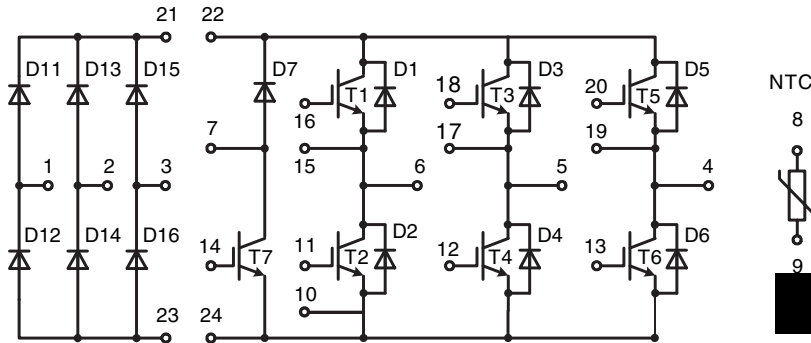

**IXYS** E 72873

Three Phase Rectifier	Brake Chopper	Three Phase Inverter
$V_{RRM} = 1600 \text{ V}$	$V_{CES} = 1200 \text{ V}$	$V_{CES} = 1200 \text{ V}$
$I_{FAVM} = 38 \text{ A}$	$I_{C25} = 30 \text{ A}$	$I_{C25} = 45 \text{ A}$
$I_{FSM} = 300 \text{ A}$	$V_{CE(sat)} = 1.7 \text{ V}$	$V_{CE(sat)} = 1.7 \text{ V}$

### Input Rectifier Bridge D11 - D16

Symbol	Conditions	Maximum Ratings	
$V_{RRM}$		1600	V
$I_{FAV}$	$T_C = 80^\circ\text{C}$ ; sine $180^\circ$	25	A
$I_{DAVM}$	$T_C = 80^\circ\text{C}$ ; rectangular; $d = 1/3$ ; bridge	72	A
$I_{FSM}$	$T_{VJ} = 25^\circ\text{C}$ ; $t = 10 \text{ ms}$ ; sine 50 Hz	300	A
$P_{tot}$	$T_C = 25^\circ\text{C}$	100	W

Symbol	Conditions	Characteristic Values ( $T_{VJ} = 25^\circ\text{C}$ , unless otherwise specified)		
		min.	typ.	max.
$V_F$	$I_F = 25 \text{ A}$ ; $T_{VJ} = 25^\circ\text{C}$ $T_{VJ} = 125^\circ\text{C}$		1.1	1.3 V V
$I_R$	$V_R = V_{RRM}$ ; $T_{VJ} = 25^\circ\text{C}$ $T_{VJ} = 125^\circ\text{C}$		0.4	0.02 mA mA
$R_{thJC}$	(per diode)			1.3 K/W

### Application: AC motor drives with

- Input from single or three phase grid
- Three phase synchronous or asynchronous motor
- electric braking operation

### Features

- High level of integration - only one power semiconductor module required for the whole drive
- Inverter with Trench IGBTs
  - low saturation voltage
  - positive temperature coefficient
  - fast switching
  - short tail current
- Epitaxial free wheeling diodes with Hiperfast and soft reverse recovery
- Industry standard package with insulated copper base plate and soldering pins for PCB mounting
- Temperature sense included

**Output Inverter T1 - T6**

Symbol	Conditions	Maximum Ratings	
$V_{CES}$	$T_{VJ} = 25^{\circ}\text{C}$ to $150^{\circ}\text{C}$	1200	V
$V_{GES}$	Continuous	$\pm 20$	V
$I_{C25}$	$T_C = 25^{\circ}\text{C}$	45	A
$I_{C80}$	$T_C = 80^{\circ}\text{C}$	25	A
$I_{CM}$	$T_C = 80^{\circ}\text{C}; t_p = 1 \text{ ms}$	50	A
$P_{tot}$	$T_C = 25^{\circ}\text{C}$	170	W

Symbol	Conditions	Characteristic Values ( $T_{VJ} = 25^{\circ}\text{C}$ , unless otherwise specified)			
		min.	typ.	max.	
$V_{CE(sat)}$	$I_C = 25 \text{ A}; V_{GE} = 15 \text{ V}; T_{VJ} = 25^{\circ}\text{C}$ $T_{VJ} = 125^{\circ}\text{C}$	1.7 2.0	2.15	V V	
$V_{GE(th)}$	$I_C = 1 \text{ mA}; V_{GE} = V_{CE}$	5	5.8	6.5	V
$I_{CES}$	$V_{CE} = V_{CES}; V_{GE} = 0 \text{ V}; T_{VJ} = 25^{\circ}\text{C}$ $T_{VJ} = 125^{\circ}\text{C}$	0.7	2.7	mA mA	
$I_{GES}$	$V_{CE} = 0 \text{ V}; V_{GE} = \pm 20 \text{ V}$		400	nA	
$C_{ies}$	$V_{CE} = 25 \text{ V}; V_{GE} = 0 \text{ V}; f = 1 \text{ MHz}$	1.8		nF	
$Q_{Gon}$	$V_{CE} = 600 \text{ V}; V_{GE} = 15 \text{ V}; I_C = 25 \text{ A}$	240		nC	
$t_{d(on)}$ $t_r$ $t_{d(off)}$ $t_f$ $E_{on}$ $E_{off}$	Inductive load, $T_{VJ} = 125^{\circ}\text{C}$ $V_{CE} = 600 \text{ V}; I_C = 25 \text{ A}$ $V_{GE} = \pm 15 \text{ V}; R_G = 36 \Omega$	90		ns	
		50		ns	
		520		ns	
		90		ns	
		2.5		mJ	
		3.4		mJ	
<b>RBSOA</b>	$I_C = I_{CM}; V_{GE} = \pm 15 \text{ V}$ $R_G = 36 \Omega; T_{VJ} = 125^{\circ}\text{C}$	$V_C$		s di/dt	
<b><math>I_{SC}</math> (SCSOA)</b>	$V_{CE} = 720 \text{ V}; V_{GE} = \pm 15 \text{ V}; R_G = 36 \Omega;$ $t_p \leq 10 \mu\text{s}; \text{non-repetitive}; T_{VJ} = 125^{\circ}\text{C}$	100		A	
$R_{thJC}$	(per IGBT)		0.73	K/W	

**Output Inverter D1 - D6**

Symbol	Conditions	Maximum Ratings	
$I_{F25}$	$T_C = 25^{\circ}\text{C}$	25	A
$I_{F80}$	$T_C = 80^{\circ}\text{C}$	17	A

Symbol	Conditions	Characteristic Values		
		min.	typ.	max.
$V_F$	$I_F = 25 \text{ A}; V_{GE} = 0 \text{ V}; T_{VJ} = 25^{\circ}\text{C}$ $T_{VJ} = 125^{\circ}\text{C}$	2.1 1.6	2.6	V V
$I_{RM}$ $Q_{rr}$ $t_{rr}$ $E_{rec}$	$I_F = \text{tbd A}; di_p/dt = -\text{tbd A}/\mu\text{s}; T_{VJ} = 125^{\circ}\text{C}$ $V_R = 600 \text{ V}; V_{GE} = 0 \text{ V}$	tbd		A
		tbd		$\mu\text{C}$
		tbd		ns
		tbd		mJ
$R_{thJC}$	(per diode)		2.1	K/W

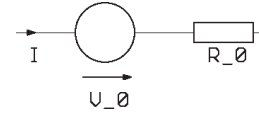
**Equivalent Circuits for Simulation**
**Conduction**

 IGBT (typ. at  $V_{GE} = 15 \text{ V}; T_J = 125^{\circ}\text{C}$ )  
T1-T6

$$V_0 = 0.92 \text{ V}; R_0 = 42.8 \text{ m}\Omega$$

T7

$$V_0 = 0.92 \text{ V}; R_0 = 72 \text{ m}\Omega$$

 Diode (typ. at  $T_J = 125^{\circ}\text{C}$ )

D1-D6

$$V_0 = \text{tbd V}; R_0 = \text{tbd m}\Omega$$

D7

$$V_0 = \text{tbd V}; R_0 = \text{tbd m}\Omega$$

D11-D16

$$V_0 = \text{tbd V}; R_0 = \text{tbd m}\Omega$$

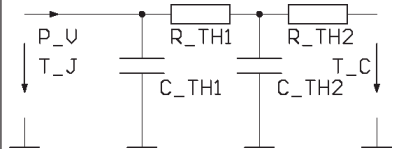
**Thermal Response**

IGBT (typ.)

T1-T6

$$C_{th1} = \text{tbd J/K}; R_{th1} = \text{tbd K/W}$$

$$C_{th2} = \text{tbd J/K}; R_{th2} = \text{tbd K/W}$$

T7

$$C_{th1} = \text{tbd J/K}; R_{th1} = \text{tbd K/W}$$

$$C_{th2} = \text{tbd J/K}; R_{th2} = \text{tbd K/W}$$

Diode (typ.)

D1-D6

$$C_{th1} = \text{tbd J/K}; R_{th1} = \text{tbd K/W}$$

$$C_{th2} = \text{tbd J/K}; R_{th2} = \text{tbd K/W}$$

D7

$$C_{th1} = \text{tbd J/K}; R_{th1} = \text{tbd K/W}$$

$$C_{th2} = \text{tbd J/K}; R_{th2} = \text{tbd K/W}$$

D11-D16

$$C_{th1} = \text{tbd J/K}; R_{th1} = \text{tbd K/W}$$

$$C_{th2} = \text{tbd J/K}; R_{th2} = \text{tbd K/W}$$

**Brake Chopper T7**

Symbol	Conditions	Maximum Ratings
$V_{CES}$	$T_{VJ} = 25^{\circ}\text{C}$ to $150^{\circ}\text{C}$	1200 V
$V_{GES}$	Continuous	$\pm 20$ V
$I_{C25}$	$T_C = 25^{\circ}\text{C}$	30 A
$I_{C80}$	$T_C = 80^{\circ}\text{C}$	15 A
$I_{CM}$	$T_C = 80^{\circ}\text{C}$ ; $t_p = 1$ ms	30 A
$P_{tot}$	$T_C = 25^{\circ}\text{C}$	120 W

Symbol	Conditions	Characteristic Values ( $T_{VJ} = 25^{\circ}\text{C}$ , unless otherwise specified)			
		min.	typ.	max.	
$V_{CE(sat)}$	$I_C = 15$ A; $V_{GE} = 15$ V; $T_{VJ} = 25^{\circ}\text{C}$ $T_{VJ} = 125^{\circ}\text{C}$		1.7 2.0	2.1 V V	
$V_{GE(th)}$	$I_C = 0.5$ mA; $V_{GE} = V_{CE}$	5	5.8	6.5 V	
$I_{CES}$	$V_{CE} = V_{CES}$ ; $V_{GE} = 0$ V; $T_{VJ} = 25^{\circ}\text{C}$ $T_{VJ} = 125^{\circ}\text{C}$		0.25	0.1 mA mA	
$I_{GES}$	$V_{CE} = 0$ V; $V_{GE} = \pm 20$ V			400 nA	
$C_{ies}$	$V_{CE} = 25$ V; $V_{GE} = 0$ V; $f = 1$ MHz		1.1	nF	
$Q_{Gon}$	$V_{CE} = 600$ V; $V_{GE} = 15$ V; $I_C = 15$ A		150	nC	
$t_{d(on)}$ $t_r$ $t_{d(off)}$ $t_f$ $E_{off}$	Inductive load, $T_{VJ} = 125^{\circ}\text{C}$ $V_{CE} = 600$ V; $I_C = 15$ A $V_{GE} = \pm 15$ V; $R_G = 75$ $\Omega$		90 50 520 90 1.5	ns ns ns ns mJ	
<b>RBSOA</b>		$I_C = I_{CM}$ ; $V_{GE} = \pm 15$ V $R_G = 75$ $\Omega$ ; $T_{VJ} = 125^{\circ}\text{C}$	$V_{CE}$		–s di/dt V
<b><math>I_{SC}</math> (SCSOA)</b>		$V_{CE} = 720$ V; $V_{GE} = \pm 15$ V; $R_G = 75$ $\Omega$ $t_p \leq 10$ $\mu\text{s}$ ; non-repetitive; $T_{VJ} = 125^{\circ}\text{C}$		60	A
$R_{thJC}$					1.05 K/W

**Brake Chopper D7**

Symbol	Conditions	Maximum Ratings
$V_{RRM}$	$T_{VJ} = 25^{\circ}\text{C}$ to $150^{\circ}\text{C}$	1200 V
$I_{F25}$	$T_C = 25^{\circ}\text{C}$	16 A
$I_{F80}$	$T_C = 80^{\circ}\text{C}$	11 A

Symbol	Conditions	Characteristic Values		
		min.	typ.	max.
$V_F$	$I_F = 65$ A; $T_{VJ} = 25^{\circ}\text{C}$ $T_{VJ} = 125^{\circ}\text{C}$		3.0 2.6	3.3 V V
$I_R$	$V_R = V_{RRM}$ ; $T_{VJ} = 25^{\circ}\text{C}$ $T_{VJ} = 125^{\circ}\text{C}$		0.07	0.06 mA mA
$R_{thJC}$				3.2 K/W

## Temperature Sensor NTC

Symbol	Conditions	Characteristic Values		
		min.	typ.	max.
$R_{25}$	$T = 25^{\circ}\text{C}$	4.75	5.0	5.25 k $\Omega$
$B_{25/50}$			3375	K

## Module

Symbol	Conditions	Maximum Ratings	
$T_{VJ}$	operating	-40...+125	$^{\circ}\text{C}$
$T_{JM}$		150	$^{\circ}\text{C}$
$T_{stg}$		-40...+125	$^{\circ}\text{C}$
$V_{ISOL}$	$I_{ISOL} \leq 1 \text{ mA}; 50/60 \text{ Hz}$	2500	V~
$M_d$	Mounting torque (M5)	2.7 - 3.3	Nm

Symbol	Conditions	Characteristic Values		
		min.	typ.	max.
$R_{pin-chip}$			5	m $\Omega$
$d_S$	Creepage distance on surface	6		mm
$d_A$	Strike distance in air	6		mm
$R_{thCH}$	with heatsink compound	0.02		K/W
<b>Weight</b>		180		g

Dimensions in mm (1 mm = 0.0394")

