



ANATECH ELECTRONICS INC
RF & Microwave Filters & Products

160 MHz LC Band Pass Filter

Part Number: AE160B11674



Electrical Specifications

Center Frequency: 160 MHz
Center Frequency Tolerance: ± 700 KHz
3dB Bandwidth (BW): 10.0 MHz
Insertion Loss @ 160MHz: 3.8 dB Max.
VSWR @ 160 MHz: 1.7:1 Max.
VSWR over 3dB BW : 3:1 Max.
Rejection1: 56dB Min @ 142 MHz
Rejection2: 60dB Min @ 178 MHz
Impedance : 50 Ohms

Mechanical

Mounting Method: Through Holes
Connector Type: SMA(F)
Dimensions: 2.5" X 1.5" x 0.38"

Environmental

Operating Temperature: -55°C to +85°C
Storage Temperature: -55°C to +85°C
Shock: 10 G. 11ms
Vibration: 10 G. 5 to 200Hz

Outline Drawing:

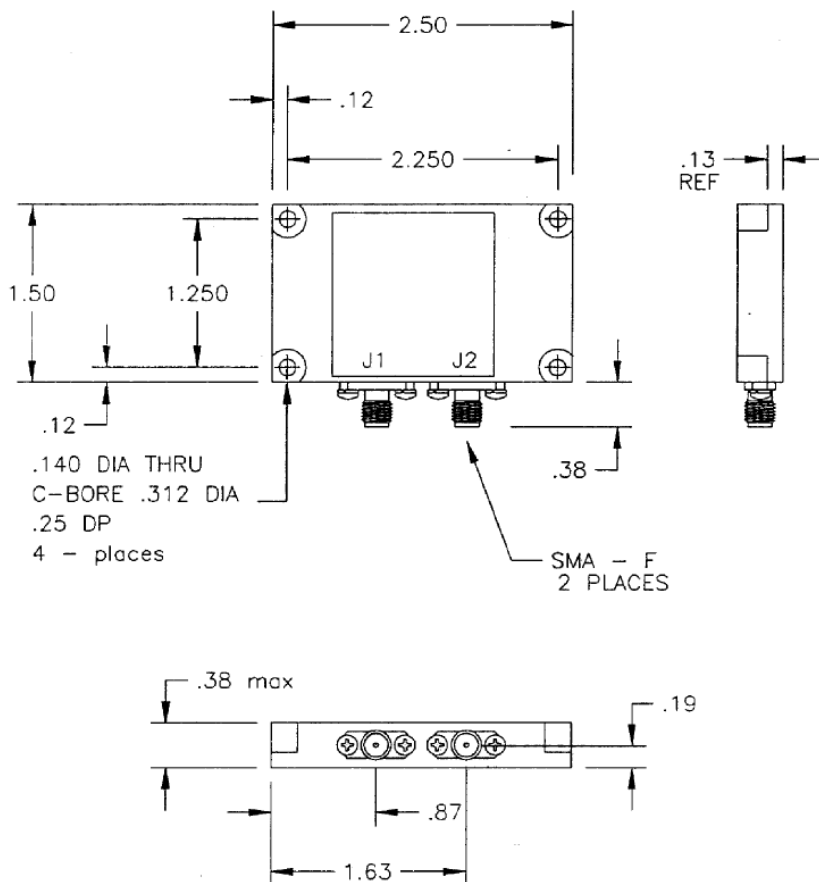

2 decimal places: +/-0.01 inches [+/- 0.3mm]

3 decimal places: +/- 0.005 inches [+/- 0.13mm]

Angles: +/- 1 Deg.

When max dimensions are called out the above tolerances do not apply as long as it is under the max call out.

70 Outwater Lane **Phone: (973) 772-4242**
Garfield, NJ 07026 **Fax : (973) 321-3941**

Email: sales@anatechelectronics.com
Web: www.anatechelectronics.com