

Dual Auto-Zeroed Operational Amplifiers

Features:

- First Monolithic Dual Auto-Zeroed Operational Amplifier
- Chopper Amplifier Performance Without External Capacitors:
 - V_{OS} : 15 μ V Max.
 - V_{OS} : Drift; 0.15 μ V/ $^{\circ}$ C Max.
 - Saves Cost of External Capacitors
- SOIC Packages Available
- High DC Gain; 120dB
- Low Supply Current; 650 μ A
- Low Input Voltage Noise:
 - 0.65 μ V_{P-P} (0.1 Hz to 10 Hz)
- Wide Common Mode Voltage Range:
 - V_{SS} to V_{DD} - 2V
- High Common Mode Rejection; 116dB
- Dual or Single Supply Operation:
 - \pm 3.3V to \pm 8.3V
 - +6.5V to +16V
- Excellent AC Operating Characteristics:
 - Slew Rate; 2.5V/ μ sec
 - Unity-Gain Bandwidth; 1.5 MHz
- Pin Compatible with LM358, OP-14, MC1458, ICL7621, TL082, TLC322

Applications:

- Instrumentation
- Medical Instrumentation
- Embedded Control
- Temperature Sensor Amplifier
- Strain Gage Amplifier

Device Selection Table

Part Number	Package	Temp. Range	Offset Voltage
TC913ACOA	8-Pin SOIC	0 $^{\circ}$ C to +70 $^{\circ}$ C	15 μ V
TC913ACPA	8-Pin PDIP	0 $^{\circ}$ C to +70 $^{\circ}$ C	15 μ V
TC913BCOA	8-Pin SOIC	0 $^{\circ}$ C to +70 $^{\circ}$ C	30 μ V
TC913BCPA	8-Pin PDIP	0 $^{\circ}$ C to +70 $^{\circ}$ C	30 μ V

Package Type

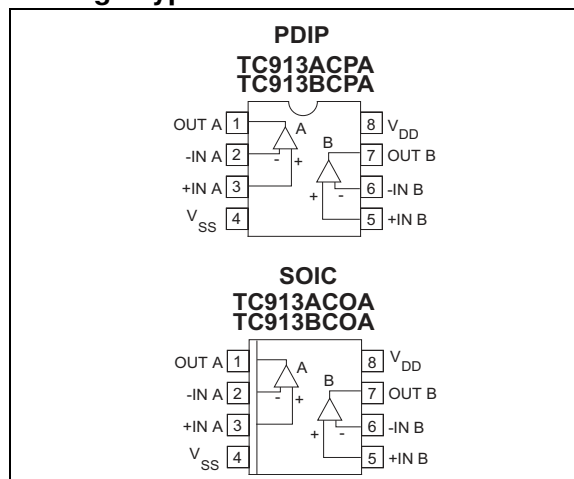

General Description:

The TC913 is the world's first complete monolithic, dual auto-zeroed operational amplifier. The TC913 sets a new standard for low-power, precision dual-operational amplifiers. Chopper-stabilized or auto-zeroed amplifiers offer low offset voltage errors by periodically sampling offset error, and storing correction voltages on capacitors. Previous single amplifier designs required two user-supplied, external 0.1 μ F error storage correction capacitors — much too large for on-chip integration. The unique TC913 architecture requires smaller capacitors, making on-chip integration possible. Microvolt offset levels are achieved and **external capacitors are not required**.

The TC913 system benefits are apparent when contrasted with a TC7650 chopper amplifier circuit implementation. A single TC913 replaces two TC7650's and four capacitors. Five components and assembly steps are eliminated.

The TC913 pinout matches many popular dual-operational amplifiers: OP-04, TLC322, LM358, and ICL7621 are typical examples. In many applications, operating from dual 5V power supplies or single supplies, the TC913 offers superior electrical performance, and can be a functional drop-in replacement; printed circuit board rework is not necessary. The TC913's low offset voltage error eliminates offset voltage trim potentiometers often needed with bipolar and low accuracy CMOS operational amplifiers.

The TC913 takes full advantage of Microchip's proprietary CMOS technology. Unity gain bandwidth is 1.5 MHz and slew rate is 2.5V/ μ sec.

TC913A/TC913B

Functional Block Diagram

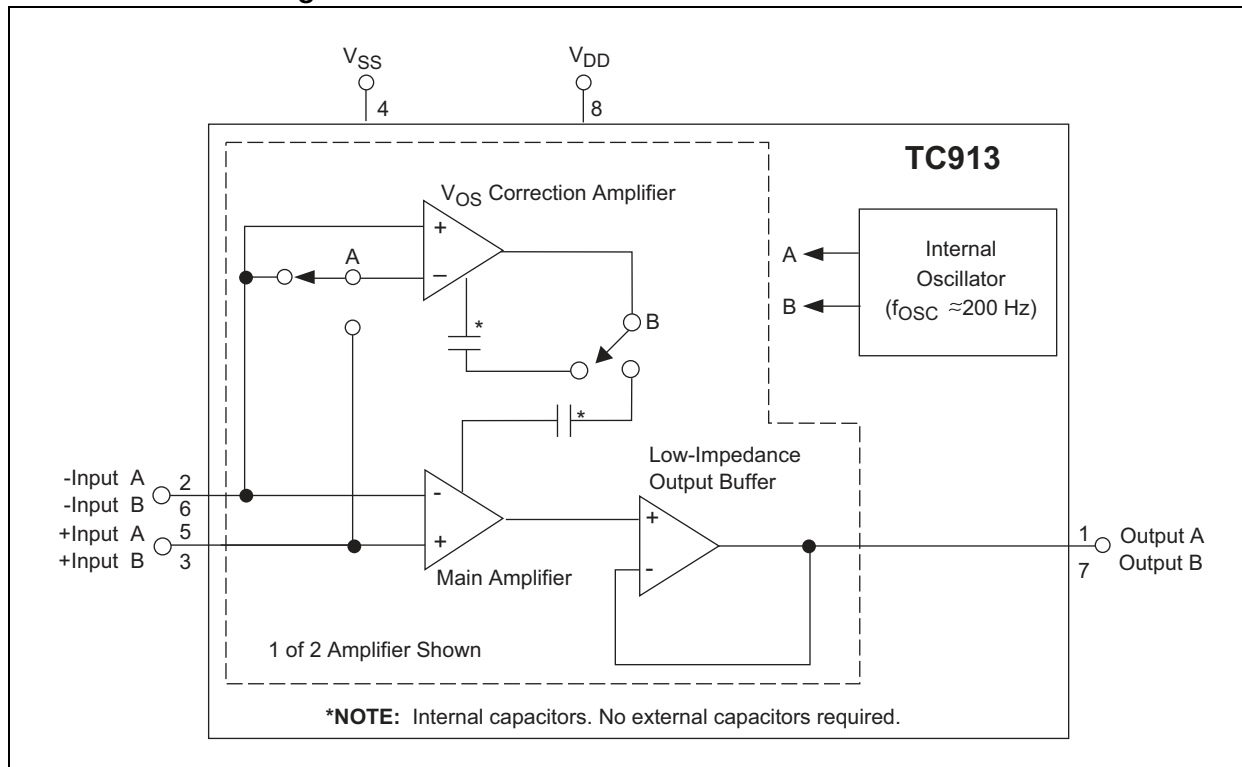

TC913A/TC913B

1.0 ELECTRICAL CHARACTERISTICS

Absolute Maximum Ratings*

Total Supply Voltage (V_{DD} to V_{SS})	+18V
Input Voltage	($V_{DD} + 0.3V$) to ($V_{SS} - 0.3V$)
Current Into Any Pin	10 mA
While Operating	100 μ A
Package Power Dissipation ($T_A = 70^\circ\text{C}$)	
Plastic DIP	730 mW
Plastic SOIC	470 mW
Operating Temperature Range	
C Device	0°C to $+70^\circ\text{C}$
Storage Temperature Range	-65°C to $+150^\circ\text{C}$

*Stresses above those listed under "Absolute Maximum Ratings" may cause permanent damage to the device. These are stress ratings only and functional operation of the device at these or any other conditions above those indicated in the operation sections of the specifications is not implied. Exposure to Absolute Maximum Rating conditions for extended periods may affect device reliability.

TC913A AND TC913B ELECTRICAL SPECIFICATIONS

Electrical Characteristics: $V_S = \pm 5V$, $T_A = +25^\circ\text{C}$, unless otherwise indicated.									
			TC913A			TC913B			
Symbol	Parameter	Min	Typ	Max	Min	Typ	Max	Unit	Test Conditions
V_{OS}	Input Offset Voltage	—	5	15	—	15	30	μV	$T_A = +25^\circ\text{C}$
TCV_{OS}	Average Temp. Coefficient of Input Offset Voltage	—	0.05	0.15	—	0.1	0.25	$\mu\text{V}/^\circ\text{C}$	$0^\circ\text{C} \leq T_A \leq +70^\circ\text{C}$
		—	0.05	0.15	—	0.1	0.25	$\mu\text{V}/^\circ\text{C}$	$-25^\circ\text{C} \leq T_A \leq +85^\circ\text{C}$ (Note 1)
I_B	Average Input Bias Current	—	—	90	—	—	120	μA	$T_A = +25^\circ\text{C}$
		—	—	3	—	—	4	nA	$0^\circ\text{C} \leq T_A \leq +70^\circ\text{C}$
		—	—	4	—	—	6	nA	$-25^\circ\text{C} \leq T_A \leq +85^\circ$
I_{OS}	Average Input Offset Current	—	5	20	—	10	40	μA	$T_A = +25^\circ\text{C}$
		—	—	1	—	—	1	nA	$T_A = +85^\circ\text{C}$
e_N	Input Voltage Noise	—	0.6	—	—	0.6	—	μV_{P-P}	0.1 to 1 Hz, $R_S \leq 100\Omega$
		—	11	—	—	11	—	μV_{P-P}	0.1 to 10 Hz, $R_S \leq 100\Omega$
CMRR	Common Mode Rejection Ratio	110	116	—	100	110	—	dB	$V_{SS} \leq V_{CM} \leq V_{DD} - 2.2$
CMVR	Common Mode Voltage Range	V_{SS}	—	$V_{DD} - 2$	V_{SS}	—	$V_{DD} - 2$	V	
A_{OL}	Open-Loop Voltage Gain	115	120	—	110	120	—	dB	$R_L = 10\text{ k}\Omega$, $V_{OUT} = \pm 4V$
V_{OUT}	Output Voltage Swing	$V_{SS} + 0.3$	—	$V_{DD} - 0.9$	$V_{SS} + 0.3$	—	$V_{DD} - 0.9$	V	$R_L = 10\text{ k}\Omega$
BW	Closed Loop Bandwidth	—	1.5	—	—	1.5	—	MHz	Closed Loop Gain = +1
SR	Slew Rate	—	2.5	—	—	2.5	—	V/ μsec	$R_L = 10\text{ k}\Omega$, $C_L = 50\text{ pF}$
PSRR	Power Supply Rejection Ratio	110	—	—	100	—	—	dB	$\pm 3.3V$ to $\pm 5.5V$
V_S	Operating Supply Voltage Range	± 3.5	—	± 8.3	± 3.5	—	± 8.3	V	Split Supply
		7.0	—	16	7.0	—	16	V	Single Supply
I_S	Quiescent Supply Current	—	0.65	0.85	—	—	1.1	mA	$V_S = \pm 5V$

Note 1: Characterized; not 100% tested.

TC913A/TC913B

2.0 PIN DESCRIPTIONS

The descriptions of the pins are listed in Table 2-1.

TABLE 2-1: PIN FUNCTION TABLE

Pin No. (8-Pin PDIP) (8-Pin SOIC)	Symbol	Description
1	OUT A	Output
2	-IN A	Inverting Input
3	+IN A	Non-inverting Input
4	V _{SS}	Negative Power Supply
5	+IN B	Non-inverting Input
6	-IN B	Inverting Input
7	OUT B	Output
8	V _{DD}	Positive Power Supply

3.0 DETAILED DESCRIPTION

3.1 Theory of Operation

Each of the TC913's two Op Amps actually consists of two amplifiers. A main amplifier is always connected from the input to the output. A separate nulling amplifier alternately nulls its own offset and then the offset of the amplifier. Since each amplifier is continuously being nulled, offset voltage drift with time, temperature and power supply variations is greatly reduced.

All nulling circuitry is internal and the nulling operation is transparent to the user. Offset nulling voltages are stored on two internal capacitors. An internal oscillator and control logic, shared by the TC913's two amplifiers, control the nulling process.

3.2 Pin Compatibility

The TC913 pinout is compatible with OP-14, LM358, MC1458, LT1013, TLC322, and similar dual Op Amps. In many circuits operating from single or $\pm 5V$ supplies, the TC913 is a drop-in replacement offering DC performance rivaling that of the best single Op Amps.

The TC913's amplifiers include a low-impedance class AB output buffer. Some previous CMOS chopper amplifiers used a high-impedance output stage which made open-loop gain dependent on load resistance. The TC913's open-loop gain is not dependent on load resistance.

3.3 Overload Recovery

The TC913 recovers quickly from output saturation. Typical recovery time from positive output saturation is 20 msec. Negative output saturation recovery time is typically 5 msec.

3.4 Avoiding Latch-up

Junction-isolated CMOS circuits inherently contain a parasitic p-n-p-n transistor circuit. Voltages exceeding the supplies by 0.3V should not be applied to the device pins. Larger voltages can turn the p-n-p-n device on, causing excessive device power supply current and power dissipation. The TC913's power supplies should be established at the same time or before input signals are applied. If this is not possible, input current should be limited to 0.1 mA to avoid triggering the p-n-p-n structure.

TC913A/TC913B

4.0 TYPICAL CHARACTERISTICS

Note: The graphs and tables provided following this note are a statistical summary based on a limited number of samples and are provided for informational purposes only. The performance characteristics listed herein are not tested or guaranteed. In some graphs or tables, the data presented may be outside the specified operating range (e.g., outside specified power supply range) and therefore outside the warranted range.

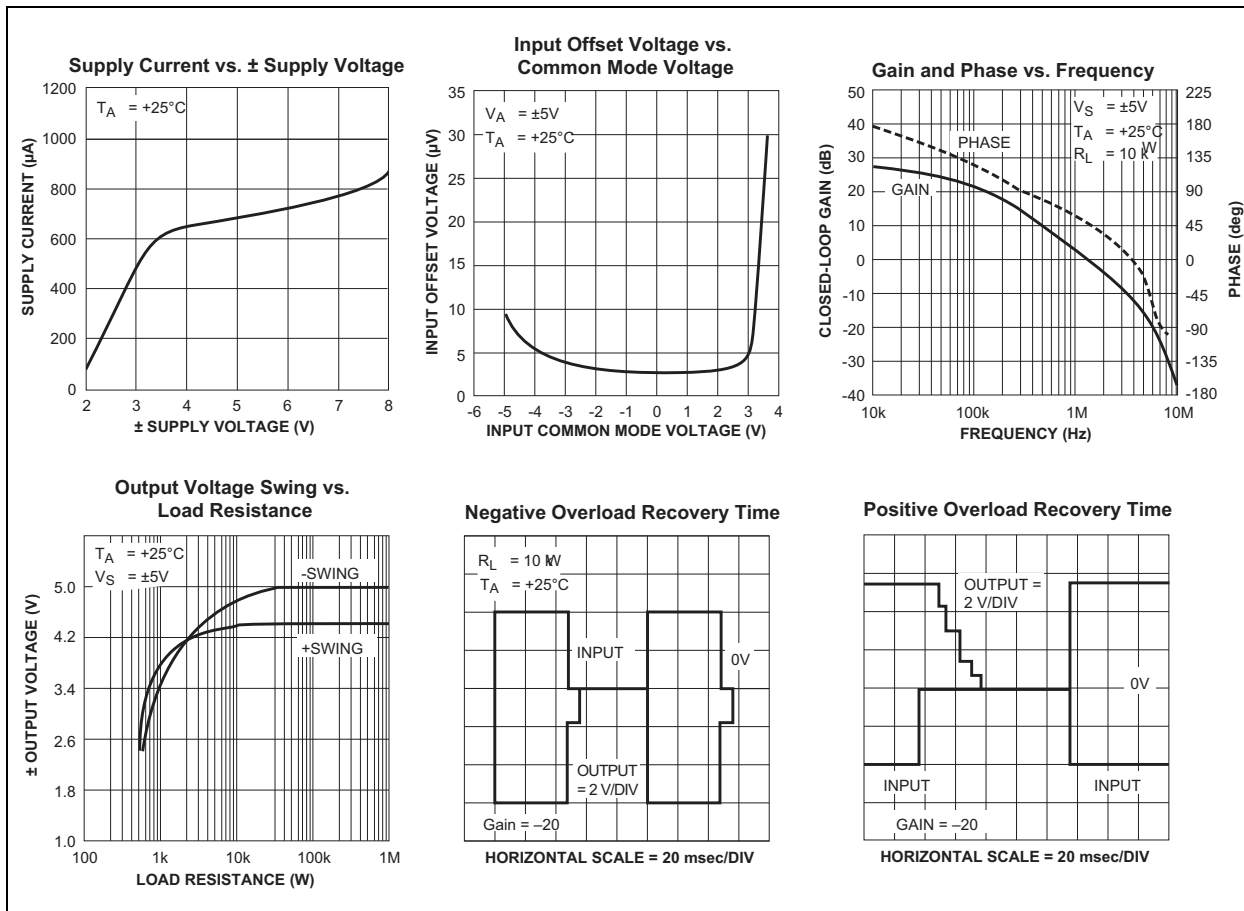

5.0 PACKAGING INFORMATION

5.1 Package Marking Information

Package marking data not available at this time.

5.2 Taping Form

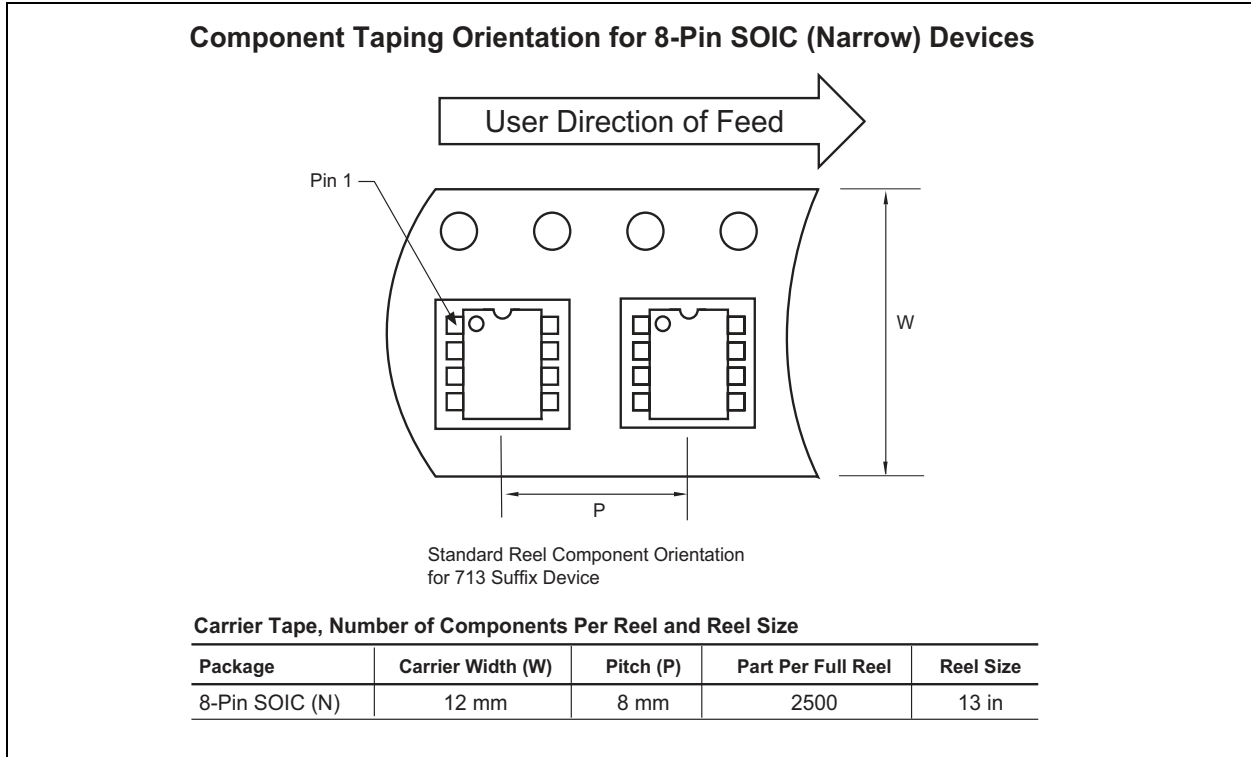

TC913A/TC913B

5.3 Package Dimensions

Note: For the most current package drawings, please see the Microchip Packaging Specification located at <http://www.microchip.com/packaging>

8-Pin SOIC

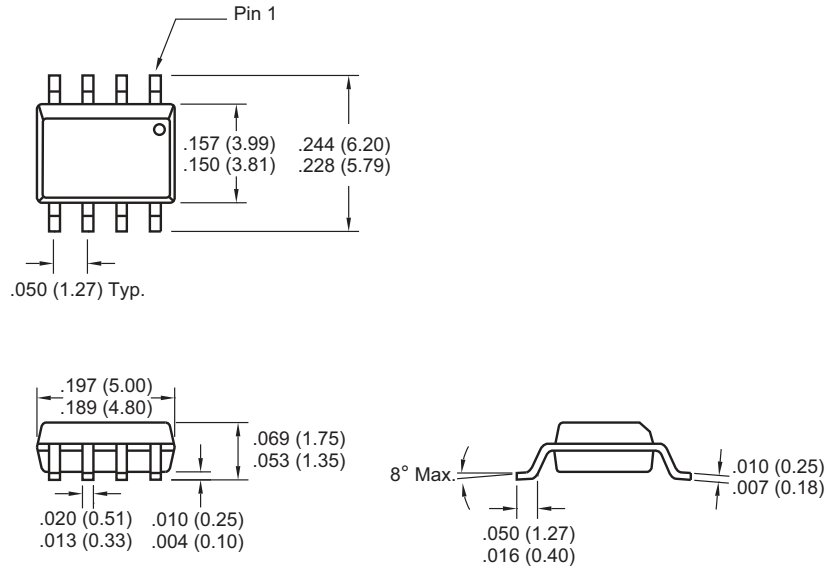

Dimensions: inches (mm)

Note: For the most current package drawings, please see the Microchip Packaging Specification located at <http://www.microchip.com/packaging>

8-Pin Plastic DIP

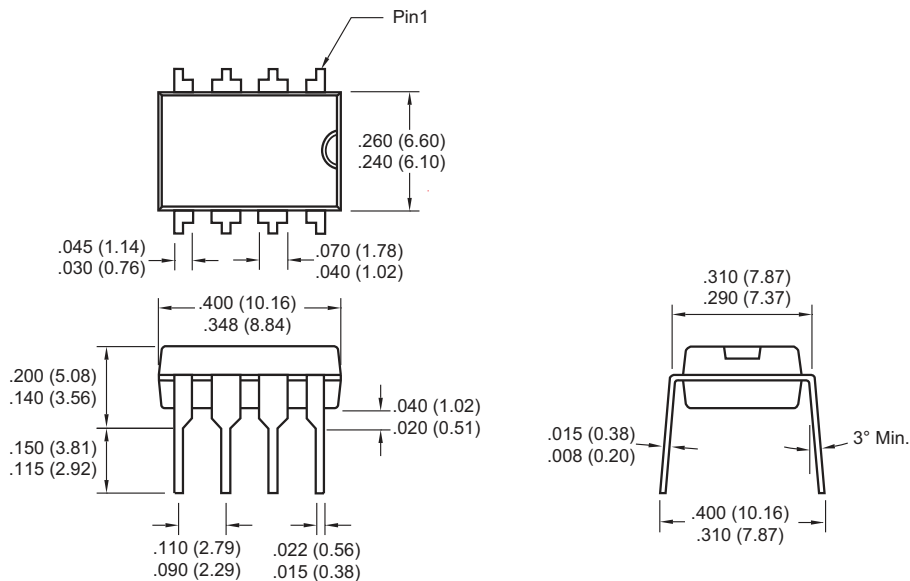

Dimensions: inches (mm)

6.0 REVISION HISTORY

Revision D (December 2012)

Added a note to each package outline drawing.

TC913A/TC913B

NOTES:

THE MICROCHIP WEB SITE

Microchip provides online support via our WWW site at www.microchip.com. This web site is used as a means to make files and information easily available to customers. Accessible by using your favorite Internet browser, the web site contains the following information:

- **Product Support** – Data sheets and errata, application notes and sample programs, design resources, user's guides and hardware support documents, latest software releases and archived software
- **General Technical Support** – Frequently Asked Questions (FAQ), technical support requests, online discussion groups, Microchip consultant program member listing
- **Business of Microchip** – Product selector and ordering guides, latest Microchip press releases, listing of seminars and events, listings of Microchip sales offices, distributors and factory representatives

CUSTOMER CHANGE NOTIFICATION SERVICE

Microchip's customer notification service helps keep customers current on Microchip products. Subscribers will receive e-mail notification whenever there are changes, updates, revisions or errata related to a specified product family or development tool of interest.

To register, access the Microchip web site at www.microchip.com. Under "Support", click on "Customer Change Notification" and follow the registration instructions.

CUSTOMER SUPPORT

Users of Microchip products can receive assistance through several channels:

- Distributor or Representative
- Local Sales Office
- Field Application Engineer (FAE)
- Technical Support

Customers should contact their distributor, representative or field application engineer (FAE) for support. Local sales offices are also available to help customers. A listing of sales offices and locations is included in the back of this document.

Technical support is available through the web site at: <http://microchip.com/support>

TC913A/TC913B

READER RESPONSE

It is our intention to provide you with the best documentation possible to ensure successful use of your Microchip product. If you wish to provide your comments on organization, clarity, subject matter, and ways in which our documentation can better serve you, please FAX your comments to the Technical Publications Manager at (480) 792-4150.

Please list the following information, and use this outline to provide us with your comments about this document.

TO: Technical Publications Manager Total Pages Sent _____

RE: Reader Response

From: Name _____

Company _____

Address _____

City / State / ZIP / Country _____

Telephone: (____) _____ - _____ FAX: (____) _____ - _____

Application (optional):

Would you like a reply? Y N

Device: TC913A/TC913B

Literature Number: DS21482D

Questions:

1. What are the best features of this document?

2. How does this document meet your hardware and software development needs?

3. Do you find the organization of this document easy to follow? If not, why?

4. What additions to the document do you think would enhance the structure and subject?

5. What deletions from the document could be made without affecting the overall usefulness?

6. Is there any incorrect or misleading information (what and where)?

7. How would you improve this document?

Note the following details of the code protection feature on Microchip devices:

- Microchip products meet the specification contained in their particular Microchip Data Sheet.
- Microchip believes that its family of products is one of the most secure families of its kind on the market today, when used in the intended manner and under normal conditions.
- There are dishonest and possibly illegal methods used to breach the code protection feature. All of these methods, to our knowledge, require using the Microchip products in a manner outside the operating specifications contained in Microchip's Data Sheets. Most likely, the person doing so is engaged in theft of intellectual property.
- Microchip is willing to work with the customer who is concerned about the integrity of their code.
- Neither Microchip nor any other semiconductor manufacturer can guarantee the security of their code. Code protection does not mean that we are guaranteeing the product as “unbreakable.”

Code protection is constantly evolving. We at Microchip are committed to continuously improving the code protection features of our products. Attempts to break Microchip's code protection feature may be a violation of the Digital Millennium Copyright Act. If such acts allow unauthorized access to your software or other copyrighted work, you may have a right to sue for relief under that Act.

Information contained in this publication regarding device applications and the like is provided only for your convenience and may be superseded by updates. It is your responsibility to ensure that your application meets with your specifications. MICROCHIP MAKES NO REPRESENTATIONS OR WARRANTIES OF ANY KIND WHETHER EXPRESS OR IMPLIED, WRITTEN OR ORAL, STATUTORY OR OTHERWISE, RELATED TO THE INFORMATION, INCLUDING BUT NOT LIMITED TO ITS CONDITION, QUALITY, PERFORMANCE, MERCHANTABILITY OR FITNESS FOR PURPOSE. Microchip disclaims all liability arising from this information and its use. Use of Microchip devices in life support and/or safety applications is entirely at the buyer's risk, and the buyer agrees to defend, indemnify and hold harmless Microchip from any and all damages, claims, suits, or expenses resulting from such use. No licenses are conveyed, implicitly or otherwise, under any Microchip intellectual property rights.

Trademarks

The Microchip name and logo, the Microchip logo, dsPIC, FlashFlex, KEELOQ, KEELOQ logo, MPLAB, PIC, PICmicro, PICSTART, PIC³² logo, rPIC, SST, SST Logo, SuperFlash and UNI/O are registered trademarks of Microchip Technology Incorporated in the U.S.A. and other countries.

FilterLab, Hampshire, HI-TECH C, Linear Active Thermistor, MTP, SEEVAL and The Embedded Control Solutions Company are registered trademarks of Microchip Technology Incorporated in the U.S.A.

Silicon Storage Technology is a registered trademark of Microchip Technology Inc. in other countries.

Analog-for-the-Digital Age, Application Maestro, BodyCom, chipKIT, chipKIT logo, CodeGuard, dsPICDEM, dsPICDEM.net, dsPICworks, dsSPEAK, ECAN, ECONOMONITOR, FanSense, HI-TIDE, In-Circuit Serial Programming, ICSP, Mindi, MiWi, MPASM, MPF, MPLAB Certified logo, MPLIB, MPLINK, mTouch, Omniclient Code Generation, PICC, PICC-18, PICDEM, PICDEM.net, PICkit, PICtail, REAL ICE, rLAB, Select Mode, SQI, Serial Quad I/O, Total Endurance, TSHARC, UniWinDriver, WiperLock, ZENA and Z-Scale are trademarks of Microchip Technology Incorporated in the U.S.A. and other countries.

SQTP is a service mark of Microchip Technology Incorporated in the U.S.A.

GestIC and ULPP are registered trademarks of Microchip Technology Germany II GmbH & Co. & KG, a subsidiary of Microchip Technology Inc., in other countries.

All other trademarks mentioned herein are property of their respective companies.

© 2001-2012, Microchip Technology Incorporated, Printed in the U.S.A., All Rights Reserved.

 Printed on recycled paper.

ISBN: 9781620768440

QUALITY MANAGEMENT SYSTEM
CERTIFIED BY DNV
== ISO/TS 16949 ==

Microchip received ISO/TS-16949:2009 certification for its worldwide headquarters, design and wafer fabrication facilities in Chandler and Tempe, Arizona; Gresham, Oregon and design centers in California and India. The Company's quality system processes and procedures are for its PIC[®] MCUs and dsPIC[®] DSCs, KEELOQ[®] code hopping devices, Serial EEPROMs, microperipherals, nonvolatile memory and analog products. In addition, Microchip's quality system for the design and manufacture of development systems is ISO 9001:2000 certified.



MICROCHIP

Worldwide Sales and Service

AMERICAS

Corporate Office
2355 West Chandler Blvd.
Chandler, AZ 85224-6199
Tel: 480-792-7200
Fax: 480-792-7277
Technical Support:
<http://www.microchip.com/support>
Web Address:
www.microchip.com

Atlanta
Duluth, GA
Tel: 678-957-9614
Fax: 678-957-1455

Boston
Westborough, MA
Tel: 774-760-0087
Fax: 774-760-0088

Chicago
Itasca, IL
Tel: 630-285-0071
Fax: 630-285-0075

Cleveland
Independence, OH
Tel: 216-447-0464
Fax: 216-447-0643

Dallas
Addison, TX
Tel: 972-818-7423
Fax: 972-818-2924

Detroit
Farmington Hills, MI
Tel: 248-538-2250
Fax: 248-538-2260

Indianapolis
Noblesville, IN
Tel: 317-773-8323
Fax: 317-773-5453

Los Angeles
Mission Viejo, CA
Tel: 949-462-9523
Fax: 949-462-9608

Santa Clara
Santa Clara, CA
Tel: 408-961-6444
Fax: 408-961-6445

Toronto
Mississauga, Ontario,
Canada
Tel: 905-673-0699
Fax: 905-673-6509

ASIA/PACIFIC

Asia Pacific Office
Suites 3707-14, 37th Floor
Tower 6, The Gateway
Harbour City, Kowloon
Hong Kong
Tel: 852-2401-1200
Fax: 852-2401-3431

Australia - Sydney
Tel: 61-2-9868-6733
Fax: 61-2-9868-6755

China - Beijing
Tel: 86-10-8569-7000
Fax: 86-10-8528-2104

China - Chengdu
Tel: 86-28-8665-5511
Fax: 86-28-8665-7889

China - Chongqing
Tel: 86-23-8980-9588
Fax: 86-23-8980-9500

China - Hangzhou
Tel: 86-571-2819-3187
Fax: 86-571-2819-3189

China - Hong Kong SAR
Tel: 852-2943-5100
Fax: 852-2401-3431

China - Nanjing
Tel: 86-25-8473-2460
Fax: 86-25-8473-2470

China - Qingdao
Tel: 86-532-8502-7355
Fax: 86-532-8502-7205

China - Shanghai
Tel: 86-21-5407-5533
Fax: 86-21-5407-5066

China - Shenyang
Tel: 86-24-2334-2829
Fax: 86-24-2334-2393

China - Shenzhen
Tel: 86-755-8864-2200
Fax: 86-755-8203-1760

China - Wuhan
Tel: 86-27-5980-5300
Fax: 86-27-5980-5118

China - Xian
Tel: 86-29-8833-7252
Fax: 86-29-8833-7256

China - Xiamen
Tel: 86-592-2388138
Fax: 86-592-2388130

China - Zhuhai
Tel: 86-756-3210040
Fax: 86-756-3210049

ASIA/PACIFIC

India - Bangalore
Tel: 91-80-3090-4444
Fax: 91-80-3090-4123

India - New Delhi
Tel: 91-11-4160-8631
Fax: 91-11-4160-8632

India - Pune
Tel: 91-20-2566-1512
Fax: 91-20-2566-1513

Japan - Osaka
Tel: 81-6-6152-7160
Fax: 81-6-6152-9310

Japan - Tokyo
Tel: 81-3-6880-3770
Fax: 81-3-6880-3771

Korea - Daegu
Tel: 82-53-744-4301
Fax: 82-53-744-4302

Korea - Seoul
Tel: 82-2-554-7200
Fax: 82-2-558-5932 or
82-2-558-5934

Malaysia - Kuala Lumpur
Tel: 60-3-6201-9857
Fax: 60-3-6201-9859

Malaysia - Penang
Tel: 60-4-227-8870
Fax: 60-4-227-4068

Philippines - Manila
Tel: 63-2-634-9065
Fax: 63-2-634-9069

Singapore
Tel: 65-6334-8870
Fax: 65-6334-8850

Taiwan - Hsin Chu
Tel: 886-3-5778-366
Fax: 886-3-5770-955

Taiwan - Kaohsiung
Tel: 886-7-213-7828
Fax: 886-7-330-9305

Taiwan - Taipei
Tel: 886-2-2508-8600
Fax: 886-2-2508-0102

Thailand - Bangkok
Tel: 66-2-694-1351
Fax: 66-2-694-1350

EUROPE

Austria - Wels
Tel: 43-7242-2244-39
Fax: 43-7242-2244-393

Denmark - Copenhagen
Tel: 45-4450-2828
Fax: 45-4485-2829

France - Paris
Tel: 33-1-69-53-63-20
Fax: 33-1-69-30-90-79

Germany - Munich
Tel: 49-89-627-144-0
Fax: 49-89-627-144-44

Italy - Milan
Tel: 39-0331-742611
Fax: 39-0331-466781

Netherlands - Drunen
Tel: 31-416-690399
Fax: 31-416-690340

Spain - Madrid
Tel: 34-91-708-08-90
Fax: 34-91-708-08-91

UK - Wokingham
Tel: 44-118-921-5869
Fax: 44-118-921-5820

11/29/12