

Board Level Heat Sinks

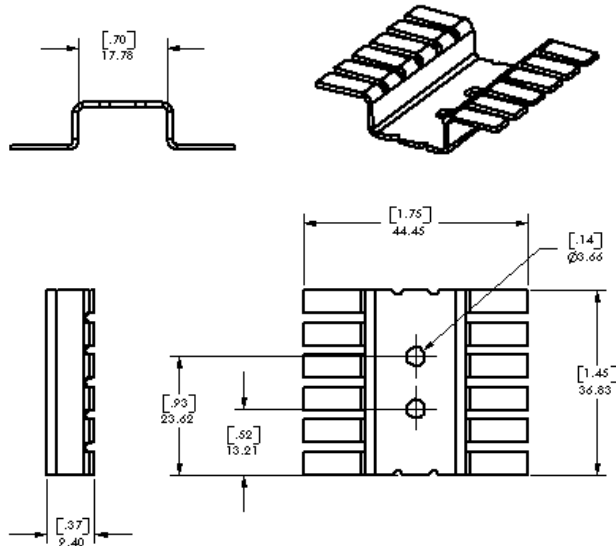

ThermaFlo

P/N: 824302B00000

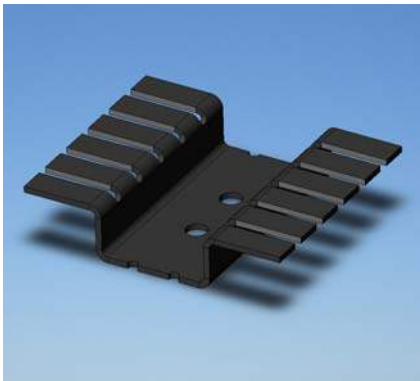

PRODUCT SPECIFICATIONS

- Devices: TO-220
- Size: 36.8 x 44.5 x 9.4 mm
- Material: Aluminum, 1.0 mm Thick
- Weight: 5.0 grams
- Type: Stamped
- PCB Mounting: Device Leads
- Finish: Black Anodized
- Package: Bulk
- Accessories: Hardware & Thermal Interface Material

FEATURES & BENEFITS

- Multiple Holes for Device Attachment
- Dual Device Cooling System
- Mates with PN 822812B00000 For Additional Cooling
- RoHS Compliant



CUSTOMIZED HEATSINKS

- Specialized Plating
- Specialized Body Configurations
- Contact Applications Engineering

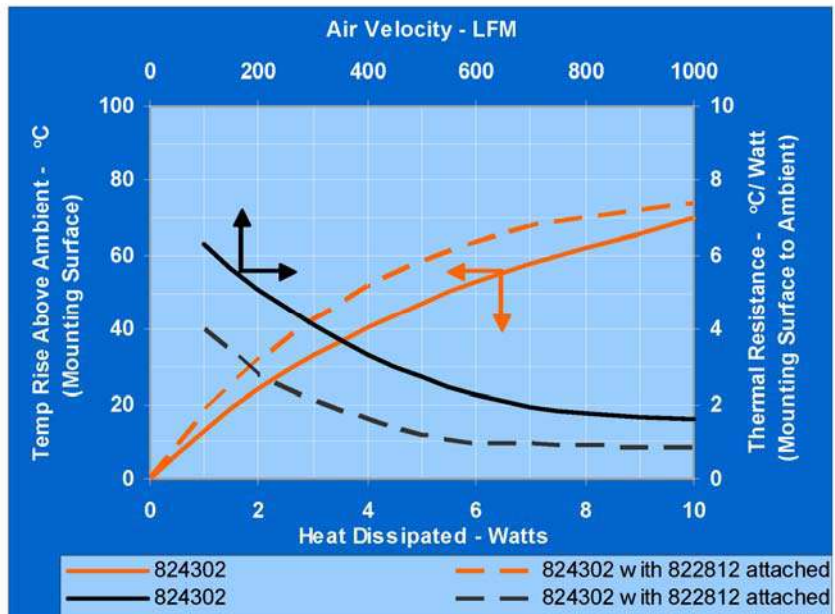

TO-220

COMAIR ROTRON, INC
 8929 Terman Court, San Diego, CA 92121
 Ph (858) 348-6200 Fax (858) 566-4577
 E-mail: sales@comairrotron.com,
 Web: www.comairrotron.com

824302B00000 - Rev B