

### FEATURES

- 3.3 V/5.2 V single-supply operation
- 150 ps propagation delay
- 15 ps overdrive and slew rate dispersion
- 8 GHz equivalent input rise time bandwidth
- 80 ps minimum pulse width
- 35 ps typical output rise/fall
- 10 ps deterministic jitter (DJ)
- 200 fs random jitter (RJ)
- On-chip terminations at both input pins
- Robust inputs with no output phase reversal
- Resistor-programmable hysteresis
- Differential latch control
- Extended industrial  $-40^{\circ}\text{C}$  to  $+125^{\circ}\text{C}$  temperature range

### APPLICATIONS

- Clock and data signal restoration and level shifting
- Automatic test equipment (ATE)
- High speed instrumentation
- Pulse spectroscopy
- Medical imaging and diagnostics
- High speed line receivers
- Threshold detection
- Peak and zero-crossing detectors
- High speed trigger circuitry

### GENERAL DESCRIPTION

The [ADCMP572](#) and [ADCMP573](#) are ultrafast comparators fabricated on Analog Devices, Inc., proprietary XFCB3 Silicon Germanium (SiGe) bipolar process. The [ADCMP572](#) features CML output drivers and latch inputs, and the [ADCMP573](#) features reduced swing PECL (RSPECL) output drivers and latch inputs.

Both devices offer 150 ps propagation delay and 80 ps minimum pulse width for 10 Gbps operation with 200 fs rms random jitter (RJ). Overdrive and slew rate dispersion are typically less than 15 ps.

A flexible power supply scheme allows both devices to operate with a single 3.3 V positive supply and a  $-0.2$  V to  $+1.2$  V input signal range or with split input/output supplies to support a wider  $-0.2$  V to  $+3.2$  V input signal range and an independent range of output levels.  $50\ \Omega$  on-chip termination resistors are

### FUNCTIONAL BLOCK DIAGRAM

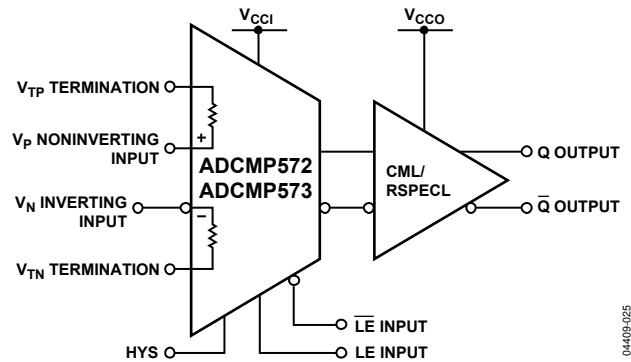

Figure 1.

04409-025

provided at both inputs with the optional capability to be left open (on an individual pin basis) for applications requiring high impedance inputs.

The CML output stage is designed to directly drive 400 mV into  $50\ \Omega$  transmission lines terminated to between 3.3 V to 5.2 V. The RSPECL output stage is designed to drive 400 mV into  $50\ \Omega$  terminated to  $V_{CCO} - 2$  V and is compatible with several commonly used PECL logic families. The comparator input stage offers robust protection against large input overdrive, and the outputs do not phase reverse when the valid input signal range is exceeded. High speed latch and programmable hysteresis features are also provided.

The [ADCMP572](#) and [ADCMP573](#) are available in a 16-lead LFCSP package and have been characterized over an extended industrial temperature range of  $-40^{\circ}\text{C}$  to  $+125^{\circ}\text{C}$ .

Rev. B

[Document Feedback](#)

Information furnished by Analog Devices is believed to be accurate and reliable. However, no responsibility is assumed by Analog Devices for its use, nor for any infringements of patents or other rights of third parties that may result from its use. Specifications subject to change without notice. No license is granted by implication or otherwise under any patent or patent rights of Analog Devices. Trademarks and registered trademarks are the property of their respective owners.

**TABLE OF CONTENTS**

Features .....	1	Power/Ground Layout and Bypassing.....	9
Applications.....	1	CML/RSPECL Output Stage.....	9
Functional Block Diagram .....	1	Using/Disabling the Latch Feature.....	9
General Description .....	1	Optimizing High Speed Performance .....	10
Revision History .....	2	Comparator Propagation Delay Dispersion .....	10
Electrical Characteristics .....	3	Comparator Hysteresis .....	11
Absolute Maximum Ratings.....	5	Minimum Input Slew Rate Requirements .....	11
Thermal Considerations.....	5	Typical Application Circuits .....	12
ESD Caution.....	5	Timing Information .....	13
Pin Configuration and Function Descriptions.....	6	Outline Dimensions .....	14
Typical Performance Characteristics .....	7	Ordering Guide .....	14
Applications Information .....	9		

**REVISION HISTORY**

**3/15—Rev. A to Rev. B**

Changes to Figure 2 and Table 3.....	6
Changes to Figure 23.....	12
Updated Outline Dimensions .....	14
Changes to Ordering Guide .....	14

**4/09—Rev. 0 to Rev. A**

Changes to Figure 26.....	12
Updated Outline Dimensions .....	14
Changes to Ordering Guide .....	14

**4/05—Revision 0: Initial Version**

## ELECTRICAL CHARACTERISTICS

$V_{CCI} = V_{CCO} = 3.3\text{ V}$ ,  $T_A = -40^\circ\text{C}$  to  $+125^\circ\text{C}$ , typical at  $T_A = +25^\circ\text{C}$ , unless otherwise noted.

Table 1.

Parameter	Symbol	Conditions	Min	Typ	Max	Unit
<b>DC INPUT CHARACTERISTICS</b>						
Input Voltage Range	$V_P, V_N$	$V_{CCI} = 3.3\text{ V}, V_{CCO} = 3.3\text{ V}$ $V_{CCI} = 5.2\text{ V}, V_{CCO} = 3.3\text{ V}$	-0.2		+1.2	V
Input Differential Voltage			-0.2		+3.1	V
Input Offset Voltage	$V_{OS}$		-1.2		+1.2	V
Offset Voltage Tempco	$\Delta V_{OS}/d_T$		-5.0	$\pm 2.0$	+5.0	mV
Input Bias Current	$I_P, I_N$	Open termination	-50.0	-25.0	0.0	$\mu\text{A}$
Input Bias Current Tempco				50.0		nA/ $^\circ\text{C}$
Input Offset Current				$\pm 2.0$		$\mu\text{A}$
Input Impedance				50		$\Omega$
Input Resistance, Differential		Open termination		50		k $\Omega$
Input Resistance, Common-Mode		Open termination		500		k $\Omega$
Active Gain	$A_V$			54		dB
Common-Mode Rejection	CMRR	$V_{CCI} = 3.3\text{ V}, V_{CCO} = 3.3\text{ V}$ , $V_{CM} = 0.0\text{ V}$ to $1.0\text{ V}$		65		dB
		$V_{CCI} = 5.2\text{ V}, V_{CCO} = 3.3\text{ V}$ , $V_{CM} = 0.0\text{ V}$ to $3.0\text{ V}$		65		dB
Power Supply Rejection— $V_{CCI}$	$PSR_{V_{CCI}}$	$V_{CCI} = 3.3\text{ V} \pm 5\%$ , $V_{CCO} = 3.3\text{ V}$		74		dB
Hysteresis		$R_{HYS} = \infty$		$\pm 1$		mV
<b>LATCH ENABLE CHARACTERISTICS</b>						
<b>ADCMP572</b>						
Latch Enable Input Range			2.8		$V_{CCO} + 0.2$	V
Latch Enable Input Differential			0.2	0.4	0.5	V
Latch Setup Time	$t_S$	$V_{OD} = 100\text{ mV}$		15		ps
Latch Hold Time	$t_H$	$V_{OD} = 100\text{ mV}$		5		ps
<b>ADCMP573</b>						
Latch Enable Input Range			1.8		$V_{CCO} - 0.6$	V
Latch Enable Input Differential			0.2	0.4	0.5	V
Latch Setup Time	$t_S$	$V_{OD} = 100\text{ mV}$		90		ps
Latch Hold Time	$t_H$	$V_{OD} = 100\text{ mV}$		100		ps
Latch Enable Input Impedance				50.0		$\Omega$
Latch to Output Delay	$t_{PLOH}, t_{PLOL}$	$V_{OD} = 100\text{ mV}$		150		ps
Latch Minimum Pulse Width	$t_{PL}$	$V_{OD} = 100\text{ mV}$		100		ps
<b>DC OUTPUT CHARACTERISTICS</b>						
<b>ADCMP572 (CML)</b>						
Output Impedance	$Z_{OUT}$	$-8\text{ mA} < I_{OUT} < 8\text{ mA}$		50.0		$\Omega$
Output Voltage High Level	$V_{OH}$	50 $\Omega$ terminate to $V_{CCO}$	$V_{CCO} - 0.10$	$V_{CCO} - 0.05$	$V_{CCO}$	V
Output Voltage Low Level	$V_{OL}$	50 $\Omega$ terminate to $V_{CCO}$	$V_{CCO} - 0.60$	$V_{CCO} - 0.45$	$V_{CCO} - 0.30$	V
Output Voltage Differential		50 $\Omega$ terminate to $V_{CCO}$	300	375	450	mV
<b>ADCMP573 (RSPECL)</b>						
Output Voltage High $-40^\circ\text{C}$	$V_{OH}$	50 $\Omega$ terminate to $V_{CCO} - 2.0$	$V_{CCO} - 1.14$	$V_{CCO} - 1.02$	$V_{CCO} - 0.90$	V
Output Voltage High $+25^\circ\text{C}$	$V_{OH}$	50 $\Omega$ terminate to $V_{CCO} - 2.0$	$V_{CCO} - 1.10$	$V_{CCO} - 0.98$	$V_{CCO} - 0.86$	V
Output Voltage High $+125^\circ\text{C}$	$V_{OH}$	50 $\Omega$ terminate to $V_{CCO} - 2.0$	$V_{CCO} - 1.04$	$V_{CCO} - 0.92$	$V_{CCO} - 0.80$	V
Output Voltage Low $-40^\circ\text{C}$	$V_{OL}$	50 $\Omega$ terminate to $V_{CCO} - 2.0$	$V_{CCO} - 1.54$	$V_{CCO} - 1.39$	$V_{CCO} - 1.24$	V
Output Voltage Low $+25^\circ\text{C}$	$V_{OL}$	50 $\Omega$ terminate to $V_{CCO} - 2.0$	$V_{CCO} - 1.50$	$V_{CCO} - 1.35$	$V_{CCO} - 1.20$	V
Output Voltage Low $+125^\circ\text{C}$	$V_{OL}$	50 $\Omega$ terminate to $V_{CCO} - 2.0$	$V_{CCO} - 1.44$	$V_{CCO} - 1.29$	$V_{CCO} - 1.14$	V
Output Voltage Differential		50 $\Omega$ terminate to $V_{CCO} - 2.0$	300	375	450	mV

Parameter	Symbol	Conditions	Min	Typ	Max	Unit
<b>AC PERFORMANCE</b>						
Propagation Delay	$t_{PD}$	$V_{CCI} = 3.3\text{ V}, V_{OD} = 200\text{ mV}$		150		Ps
		$V_{CCI} = 3.3\text{ V}, V_{OD} = 20\text{ mV}$		165		Ps
		$V_{CCI} = 5.2\text{ V}, V_{OD} = 200\text{ mV}$		145		Ps
Propagation Delay Tempco	$\Delta t_{PD}/dT$			0.5		ps/°C
Prop Delay Skew—Rising Transition to Falling Transition		$V_{OD} = 200\text{ mV}, 5\text{ V/ns}$		10		Ps
Overdrive Dispersion		$50\text{ mV} < V_{OD} < 0.2\text{ V}, 5\text{ V/ns}$		15		Ps
		$10\text{ mV} < V_{OD} < 0.2\text{ V}, 5\text{ V/ns}$		15		Ps
Slew Rate Dispersion		$2\text{ V/ns to } 10\text{ V/ns}, 250\text{ mV OD}$		15		Ps
Pulse Width Dispersion		$100\text{ ps to } 5\text{ ns}, 250\text{ mV OD}$		5		Ps
10% – 90% Duty Cycle Dispersion		$V_{CCI} = 3.3\text{ V}, 1\text{ V/ns}, 250\text{ mV OD}$		5		Ps
		$V_{CCI} = 5.2\text{ V}, 1\text{ V/ns}, 250\text{ mV OD}$		10		Ps
Common-Mode Dispersion		$V_{OD} = 0.2\text{ V}, 0.0\text{ V} < V_{CM} < 2.9\text{ V}$		5		ps/V
Equivalent Input Bandwidth <sup>1</sup>	$BW_{EQ}$	$0.0\text{ V to } 250\text{ mV input}$ $t_R = t_F = 17\text{ ps}, 20/80$		8.0		GHz
Toggle Rate		$>50\%$ Output Swing		12.5		Gbps
Deterministic Jitter	DJ	$V_{OD} = 200\text{ mV}, 5\text{ V/ns},$ PRBS <sup>31</sup> – 1 NRZ, 4 Gbps		10		Ps
		$V_{OD} = 200\text{ mV}, 5\text{ V/ns},$ PRBS <sup>31</sup> – 1 NRZ, 10 Gbps		20		Ps
RMS Random Jitter	RJ	$V_{OD} = 200\text{ mV}, 5\text{ V/ns}, 1.25\text{ GHz}$		0.2		Ps
Minimum Pulse Width	$PW_{MIN}$	$\Delta t_{PD}/\Delta PW < 5\text{ ps}, 200\text{ mV OD}$		100		Ps
	$PW_{MIN}$	$\Delta t_{PD}/\Delta PW < 10\text{ ps}, 200\text{ mV OD}$		80		Ps
Rise Time	$t_R$	20/80		35		Ps
Fall Time	$t_F$	20/80		35		Ps
<b>POWER SUPPLY</b>						
Input Supply Voltage Range	$V_{CCI}$		3.1		5.4	V
Output Supply Voltage Range	$V_{CCO}$		3.1		5.4	V
Positive Supply Differential	$V_{CCI} - V_{CCO}$		-0.2		+2.3	V
<b>ADCMP572 (CML)</b>						
Positive Supply Current	$I_{VCCI} + I_{VCCO}$	$V_{CCI} = 3.3\text{ V}, V_{CCO} = 3.3\text{ V},$ terminate $50\ \Omega$ to $V_{CCO}$		44	52	mA
		$V_{CCI} = 5.2\text{ V}, V_{CCO} = 5.2\text{ V},$ terminate $50\ \Omega$ to $V_{CCO}$		44	52	mA
Device Power Dissipation	$P_D$	$V_{CCI} = 3.3\text{ V}, V_{CCO} = 3.3\text{ V},$ terminate $50\ \Omega$ to $V_{CCO}$		140	165	mW
		$V_{CCI} = 5.2\text{ V}, V_{CCO} = 5.2\text{ V},$ terminate $50\ \Omega$ to $V_{CCO}$		230	265	mW
<b>ADCMP573 (RSPECL)</b>						
Positive Supply Current	$I_{VCCI} + I_{VCCO}$	$V_{CCI} = 3.3\text{ V}, V_{CCO} = 3.3\text{ V},$ $50\ \Omega$ to $V_{CCO} - 2\text{ V}$		62	80	mA
		$V_{CCI} = 5.2\text{ V}, V_{CCO} = 5.2\text{ V},$ $50\ \Omega$ to $V_{CCO} - 2\text{ V}$		64	80	mA
Device Power Dissipation	$P_D$	$V_{CCI} = 3.3\text{ V}, V_{CCO} = 3.3\text{ V},$ $50\ \Omega$ to $V_{CCO} - 2\text{ V}$		110	160	mW
		$V_{CCI} = 5.2\text{ V}, V_{CCO} = 5.2\text{ V},$ $50\ \Omega$ to $V_{CCO} - 2\text{ V}$		146	230	mW

<sup>1</sup> Equivalent input bandwidth assumes a simple first-order response and is calculated with the following formula:  $BW_{EQ} = 0.22/\sqrt{(t_{rCOMP}^2 - t_{rIN}^2)}$ , where  $t_{rIN}$  is the 20/80 transition time of a quasi-Gaussian signal applied to the comparator input, and  $t_{rCOMP}$  is the effective transition time digitized by the comparator.

## ABSOLUTE MAXIMUM RATINGS

Table 2.

Parameter	Rating
SUPPLY VOLTAGE	
Input Supply Voltage ( $V_{CC1}$ to GND)	-0.5 V to +6.0 V
Output Supply Voltage ( $V_{CC0}$ to GND)	-0.5 V to +6.0 V
Positive Supply Differential ( $V_{CC1} - V_{CC0}$ )	-0.5 V to +3.5 V
INPUT VOLTAGE	
Input Voltage	-0.5 V to $V_{CC1} + 0.5$ V
Differential Input Voltage	$\pm(V_{CC1} + 0.5$ V)
Input Voltage, Latch Enable	-0.5 V to $V_{CC0} + 0.5$ V
HYSTERESIS CONTROL PIN	
Applied Voltage (HYS to GND)	-0.5 V to +1.5 V
Maximum Input/Output Current	$\pm 1$ mA
OUTPUT CURRENT	
ADCMP572 (CML)	$\pm 20$ mA
ADCMP573 (RSPECL)	-35 mA
TEMPERATURE	
Operating Temperature, Ambient	-40°C to +125°C
Operating Temperature, Junction	+150°C
Storage Temperature Range	-65°C to +150°C

Stresses at or above those listed under Absolute Maximum Ratings may cause permanent damage to the product. This is a stress rating only; functional operation of the product at these or any other conditions above those indicated in the operational section of this specification is not implied. Operation beyond the maximum operating conditions for extended periods may affect product reliability.

## THERMAL CONSIDERATIONS

The ADCMP572/ADCMP573 LFCSP 16-lead package has a  $\theta_{JA}$  (junction-to-ambient thermal resistance) of 70°C/W in still air.

## ESD CAUTION



**ESD (electrostatic discharge) sensitive device.** Charged devices and circuit boards can discharge without detection. Although this product features patented or proprietary protection circuitry, damage may occur on devices subjected to high energy ESD. Therefore, proper ESD precautions should be taken to avoid performance degradation or loss of functionality.

PIN CONFIGURATION AND FUNCTION DESCRIPTIONS

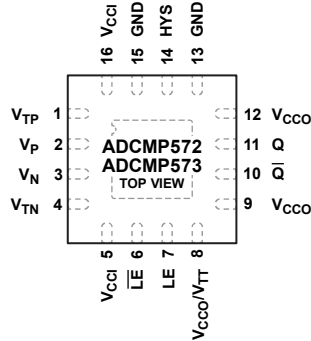

NOTES  
 1. LEAVE EPAD FLOATING UNLESS IMPROVED THERMAL OR MECHANICAL STABILITY IS DESIRED, IN WHICH CASE SOLDER IT TO THE APPLICATION BOARD.

04409-028

Figure 2. ADCMP572/ADCMP573 Pin Configuration

Table 3. Pin Function Descriptions

Pin No.	Mnemonic	Description
1	V <sub>TP</sub>	Termination Resistor Return Pin for V <sub>P</sub> Input.
2	V <sub>P</sub>	Noninverting Analog Input.
3	V <sub>N</sub>	Inverting Analog Input.
4	V <sub>TN</sub>	Termination Resistor Return Pin for V <sub>N</sub> Input.
5, 16	V <sub>CCI</sub>	Positive Supply Voltage for Input Stage.
6	$\overline{LE}$	Latch Enable Input Pin, Inverting Side. In compare mode ( $\overline{LE}$ = low), the output tracks changes at the input of the comparator. In latch mode ( $\overline{LE}$ = high), the output reflects the input state just prior to the comparator's being placed into latch mode. $\overline{LE}$ must be driven in complement with LE.
7	LE	Latch Enable Input Pin, Noninverting Side. In compare mode (LE = high), the output tracks changes at the input of the comparator. In latch mode (LE = low), the output reflects the input state just prior to the comparator's being placed into latch mode. LE must be driven in complement with $\overline{LE}$ .
8	V <sub>CCO</sub> /V <sub>TT</sub>	Termination Return Pin for the LE/ $\overline{LE}$ Input Pins. For the ADCMP572 (CML output stage), this pin is internally connected to and also should be externally connected to the positive V <sub>CCO</sub> supply. For the ADCMP573 (RSPECL output stage), this pin should normally be connected to the V <sub>CCO</sub> – 2 V termination potential.
9, 12	V <sub>CCO</sub>	Positive Supply Voltage for the CML/RSPECL Output Stage.
13, 15	GND	Ground.
10	$\overline{Q}$	Inverting Output. $\overline{Q}$ is at logic low if the analog voltage at the noninverting input, V <sub>P</sub> , is greater than the analog voltage at the inverting input, V <sub>N</sub> , provided the comparator is in compare mode. See the LE/ $\overline{LE}$ descriptions (Pins 6 and 7) for more information.
11	Q	Noninverting Output. Q is at logic high if the analog voltage at the noninverting input V <sub>P</sub> is greater than the analog voltage at the inverting input, V <sub>N</sub> , provided the comparator is in compare mode. See the LE/ $\overline{LE}$ descriptions (Pins 6 and 7) for more information.
14	HYS	Hysteresis Control Pin. Leave this pin disconnected for zero hysteresis. Connect to GND with a suitably sized resistor to add the desired amount of hysteresis. Refer to Figure 7 for proper sizing of R <sub>HYS</sub> hysteresis control resistor.
	Isolated Heat Sink	The metallic back surface of the package is not electrically connected to any part of the circuit, and it can be left floating for best electrical isolation between the package handle and the substrate of the die. However, it can be soldered to the application board if improved thermal and/or mechanical stability is desired. Exposed metal at package corners is connected to the heat sink paddle.
	EPAD	Exposed Pad. Leave EPAD floating unless improved thermal or mechanical stability is desired, in which case solder it to the application board.

# TYPICAL PERFORMANCE CHARACTERISTICS

$V_{CCI} = V_{CCO} = 3.3\text{ V}$ ,  $T_A = 25^\circ\text{C}$ , unless otherwise noted.

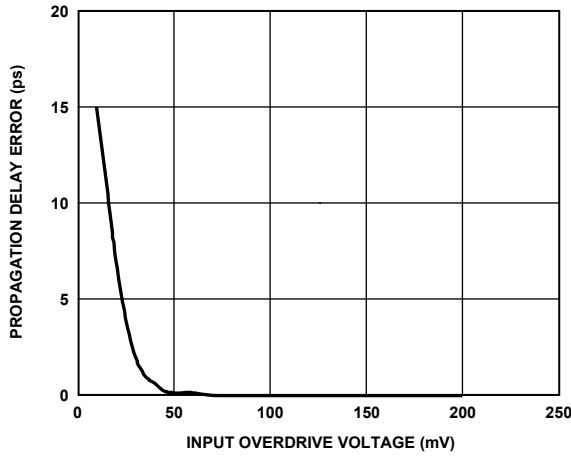

Figure 3. Propagation Delay vs. Input Overdrive

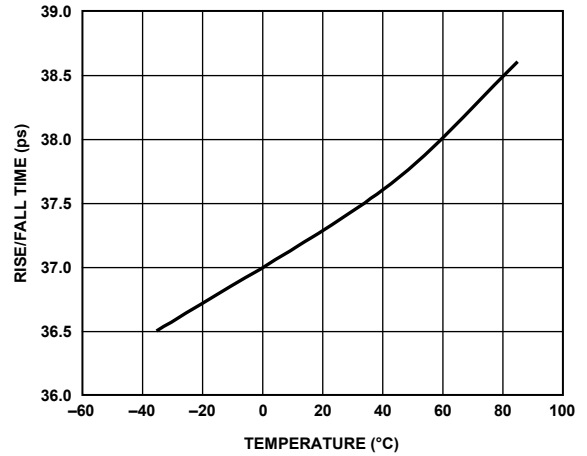

Figure 6. Rise/Fall Time vs. Temperature

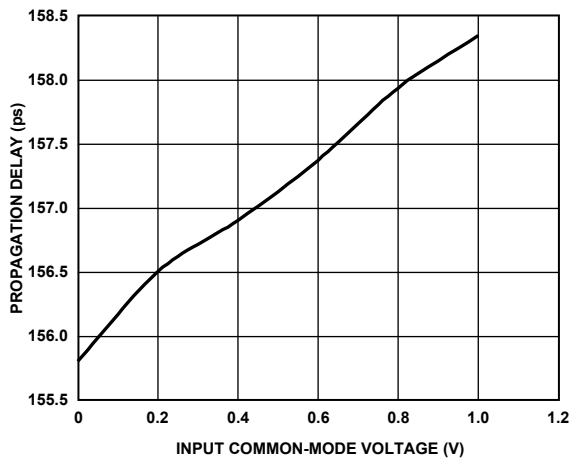

Figure 4. Propagation Delay vs. Input Common-Mode

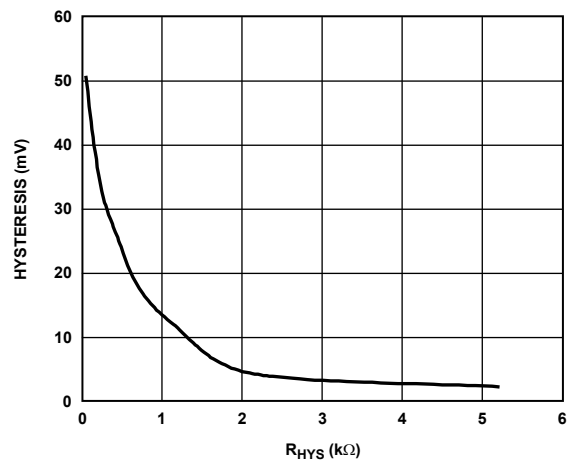

Figure 7. Hysteresis vs.  $R_{HYS}$  Control Resistor

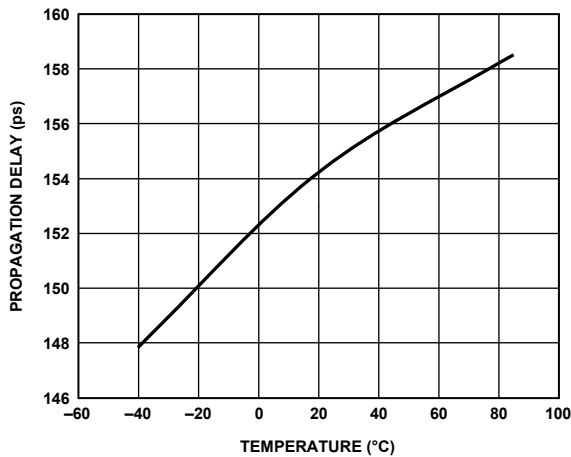

Figure 5. Propagation Delay vs. Temperature

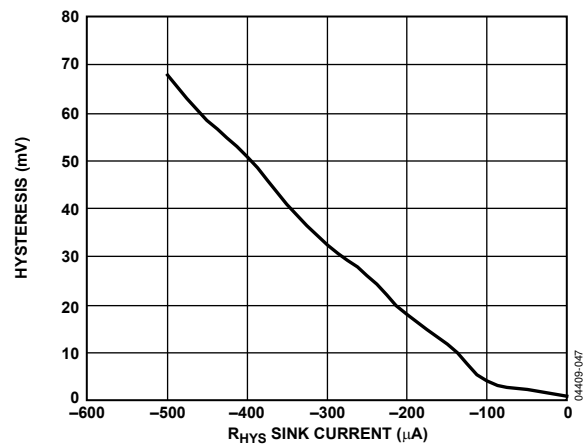

Figure 8. Hysteresis vs.  $R_{HYS}$  Sink Current

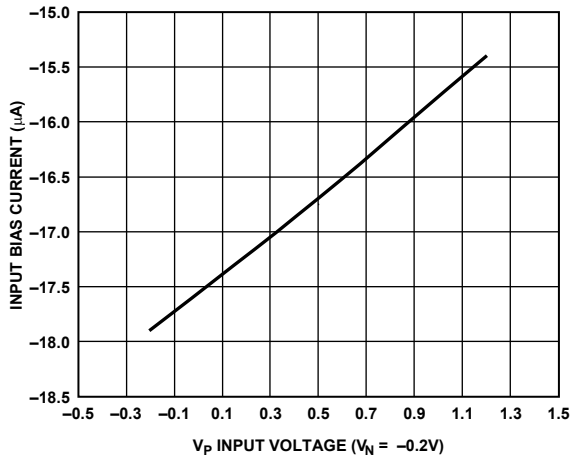

Figure 9. Input Bias Current vs. Input Differential

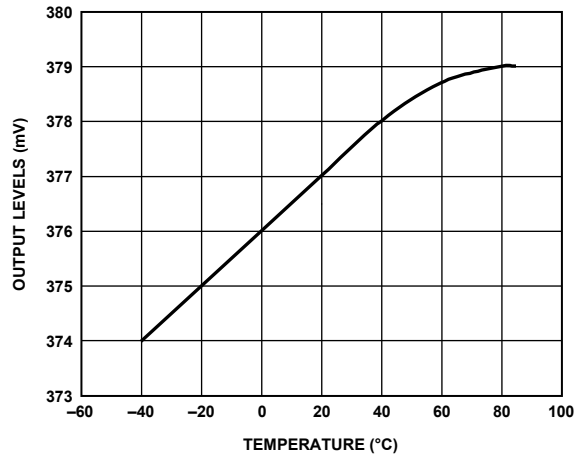

Figure 12. Output Levels vs. Temperature

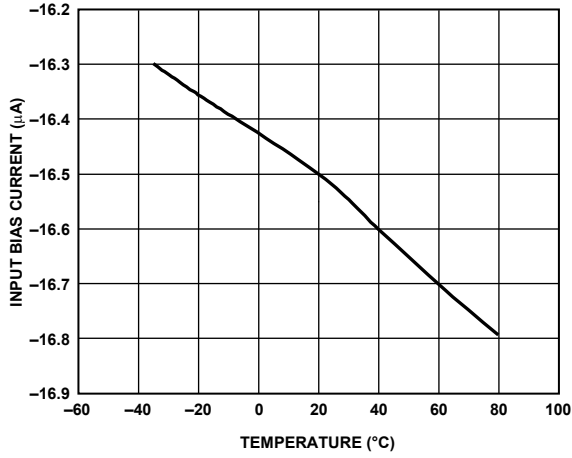

Figure 10. Input Bias Current vs. Temperature

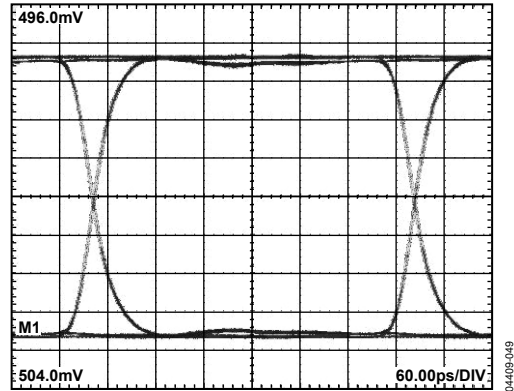

Figure 13. ADCMP572 Eye Diagram at 2.5 Gbps

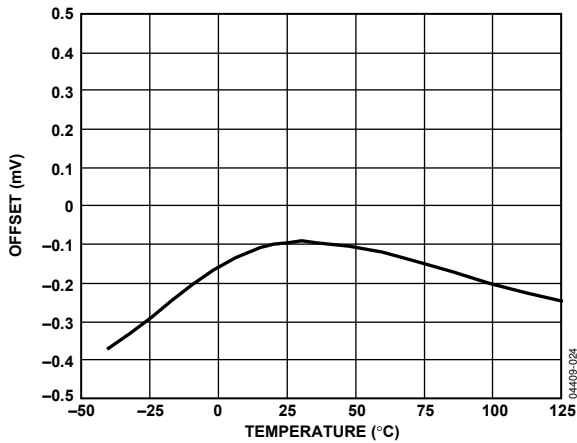

Figure 11. Input Offset Voltage vs. Temperature

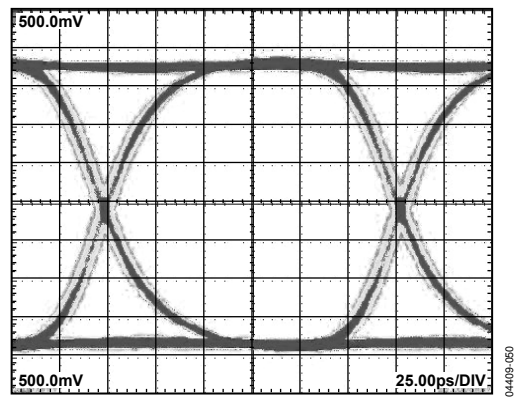

Figure 14. ADCMP572 Eye Diagram at 6.5 Gbps



## APPLICATIONS INFORMATION

### POWER/GROUND LAYOUT AND BYPASSING

The [ADCMP572/ADCMP573](#) comparators are very high speed SiGe devices. Consequently, it is essential to use proper high speed design techniques to achieve the specified performance. Of critical importance is the use of low impedance supply planes, particularly the output supply plane ( $V_{CCO}$ ) and the ground plane (GND). Individual supply planes are recommended as part of a multilayer board. Providing the lowest inductance return path for switching currents ensures the best possible performance in the target application.

It is important to adequately bypass the input and output supplies. A 1  $\mu$ F electrolytic bypass capacitor should be placed within several inches of each power supply pin to ground. In addition, multiple high quality 0.01  $\mu$ F bypass capacitors should be placed as close as possible to each of the  $V_{CCI}$  and  $V_{CCO}$  supply pins and should be connected to the GND plane with redundant vias. High frequency bypass capacitors should be carefully selected for minimum inductance and ESR. Parasitic layout inductance should be avoided to maximize the effectiveness of the bypass at high frequencies.

If the input and output supplies are connected separately such that  $V_{CCI} \neq V_{CCO}$ , care should be taken to bypass each of these supplies separately to the GND plane. A bypass capacitor should not be connected between them. It is recommended that the GND plane separate the  $V_{CCI}$  and  $V_{CCO}$  planes when the circuit board layout is designed to minimize coupling between the two supplies and to take advantage of the additional bypass capacitance from each respective supply to the ground plane. This enhances the performance when split input/output supplies are used. If the input and output supplies are connected together for single-supply operation such that  $V_{CCI} = V_{CCO}$ , coupling between the two supplies is unavoidable; however, every effort should be made to keep the supply plane adjacent to the GND plane to maximize the additional bypass capacitance this arrangement provides.

### CML/RSPECL OUTPUT STAGE

Specified propagation delay dispersion performance can be achieved only by using proper transmission line terminations. The outputs of the [ADCMP572](#) are designed to directly drive 400 mV into 50  $\Omega$  cable, microstrip, or strip line transmission lines properly terminated to the  $V_{CCO}$  supply plane. The CML output stage is shown in the simplified schematic diagram of Figure 15. The outputs are each back terminated with 50  $\Omega$  for best transmission line matching. The RSPECL outputs of the [ADCMP573](#) are illustrated in Figure 16 and should be terminated to  $V_{CCO} - 2$  V. As an alternative, Thevenin equivalent termination networks can be used in either case if the direct termination voltage is not readily available. If high speed output signals must be routed more than a centimeter, microstrip or strip line techniques are essential to ensure proper transition times and to

prevent output ringing and pulse width dependent propagation delay dispersion. For the most timing critical applications where transmission line reflections pose the greatest risk to performance, the [ADCMP572](#) provides the best match to 50  $\Omega$  output transmission paths.

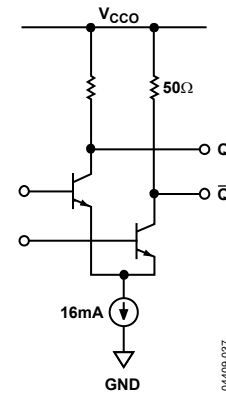

Figure 15. Simplified Schematic Diagram of the [ADCMP572](#) CML Output Stage

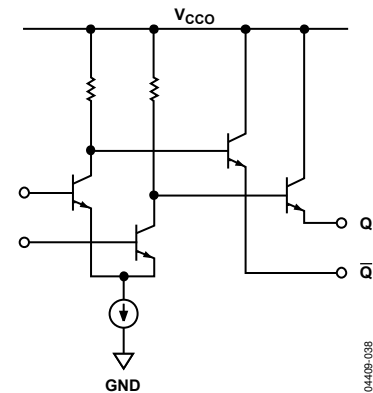

Figure 16. Simplified Schematic Diagram of the [ADCMP573](#) RSPECL Output Stage

### USING/DISABLING THE LATCH FEATURE

The latch inputs ( $\overline{LE}/\overline{LE}$ ) are active low for latch mode and are internally terminated with 50  $\Omega$  resistors to Pin 8. This pin corresponds to and is internally connected to the  $V_{CCO}$  supply for the CML-compatible [ADCMP572](#). With the aid of these resistors, the [ADCMP572](#) latch function can be disabled by connecting the  $\overline{LE}$  pin to GND with an external pull-down resistor and leaving the LE pin unconnected. To avoid excessive power dissipation, the resistor should be 750  $\Omega$  when  $V_{CCO} = 3.3$  V, and 1.2 k $\Omega$  when  $V_{CCO} = 5.2$  V. In the PECL-compatible [ADCMP573](#), the  $V_{TT}$  pin should be connected externally to the PECL termination supply at  $V_{CCO} - 2$  V. The latch can then be disabled by connecting the LE pin to  $V_{CCO}$  with an external 500  $\Omega$  resistor and leaving the  $\overline{LE}$  pin disconnected. In this case, the resistor value does not depend on the  $V_{CCO}$  supply voltage.

$V_{CCO}$  is the signal return for the output stage and  $V_{CCO}$  pins should of course be connected to a supply plane for maximum performance.

## OPTIMIZING HIGH SPEED PERFORMANCE

As with any high speed comparator, proper design and layout techniques are essential to obtaining the specified performance. Stray capacitance, inductance, inductive power and ground impedances, or other layout issues can severely limit performance and often cause oscillation. Discontinuities along input and output transmission lines can severely limit the specified pulse width dispersion performance.

For applications working in a 50  $\Omega$  environment, input and output matching has a significant impact on data dependent (or deterministic) jitter (DJ) and on pulse width dispersion performance. The ADCMP572/ADCMP573 comparators provide internal 50  $\Omega$  termination resistors for both the  $V_P$  and  $V_N$  inputs, and the ADCMP572 provides 50  $\Omega$  back terminated outputs. The return side for each input termination is pinned out separately with the  $V_{TP}$  and  $V_{TN}$  pins, respectively. If a 50  $\Omega$  termination is desired at one or both of the  $V_P/V_N$  inputs, then the  $V_{TP}$  and  $V_{TN}$  pins can be connected (or disconnected) to (from) the desired termination potential as required. The termination potential should be carefully bypassed using high quality bypass capacitors as discussed earlier to prevent undesired aberrations on the input signal due to parasitic inductance in the circuit board layout. If a 50  $\Omega$  input termination is not desired, either one or both of the  $V_{TP}/V_{TN}$  termination pins can be left disconnected. In this case, the pins should be left floating with no external pull-downs or bypassing capacitors.

When leaving an input termination disconnected, the internal resistor acts as a small stub on the input transmission path and can cause problems for very high speed inputs. Reflections should then be expected from the comparator inputs because they no longer provide matched impedance to the input path leading to the device. In this case, it is important to back match the drive source impedance to the input transmission path to minimize multiple reflections. For applications in which the comparator is very close to the driving signal source, the source impedance should be minimized. High source impedance in combination with parasitic input capacitance of the comparator might cause an undesirable degradation in bandwidth at the input, therefore degrading the overall response. Although the ADCMP572/ADCMP573 comparators have been designed to minimize input capacitance, some parasitic capacitance is inevitable. It is therefore recommended that the drive source impedance be no more than 50  $\Omega$  for best high speed performance.

## COMPARATOR PROPAGATION DELAY DISPERSION

The ADCMP572/ADCMP573 comparators are designed to reduce propagation delay dispersion over a wide input overdrive range of 5 mV to 500 mV. Propagation delay dispersion is variation in the propagation delay that results from a change in the degree of overdrive or slew rate (how far or how fast the input signal exceeds the switching threshold).

Propagation delay dispersion is a specification that becomes important in high speed, time-critical applications such as data communication, automatic test and measurement, instrumentation, and event driven applications such as pulse spectroscopy, nuclear instrumentation, and medical imaging. Dispersion is defined as the variation in propagation delay as the input overdrive conditions vary (Figure 17 and Figure 18). For the ADCMP572/ADCMP573, dispersion is typically <15 ps because the overdrive varies from 10 mV to 500 mV, and the input slew rate varies from 2 V/ns to 10 V/ns. This specification applies for both positive and negative signals since the ADCMP572/ADCMP573 has substantially equal delays for either positive going or negative going inputs.

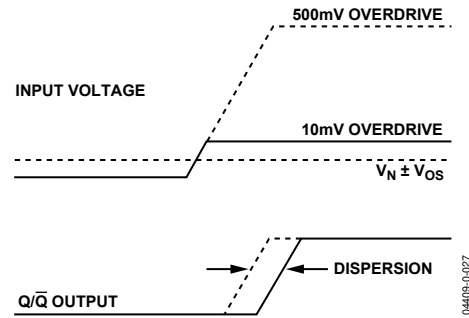

Figure 17. Propagation Delay—Overdrive Dispersion

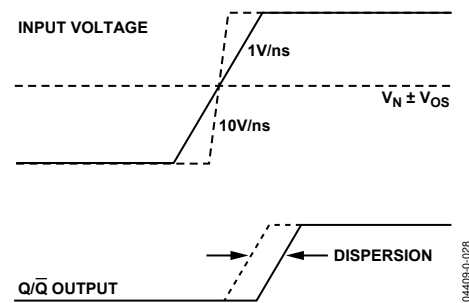

Figure 18. Propagation Delay—Slew Rate Dispersion

## COMPARATOR HYSTERESIS

The addition of hysteresis to a comparator is often desirable in a noisy environment or when the differential input amplitudes are relatively small or slow moving, but excessive hysteresis has a cost in degraded accuracy and slew-induced timing shifts. The transfer function for a comparator with hysteresis is shown in Figure 19. If the input voltage approaches the threshold (0.0 V in this example) from the negative direction, the comparator switches from low to high when the input crosses  $+V_H/2$ . The new switching threshold becomes  $-V_H/2$ . The comparator remains in the high state until the threshold  $-V_H/2$  is crossed from the positive direction. In this manner, noise centered on 0.0 V input does not cause the comparator to switch states unless it exceeds the region bounded by  $\pm V_H/2$ .

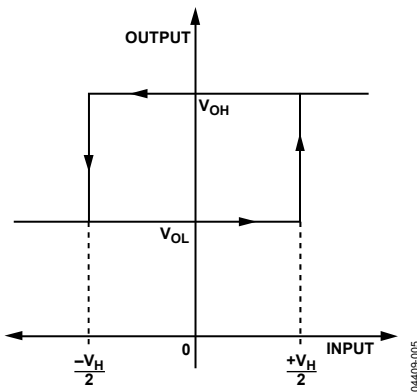

Figure 19. Comparator Hysteresis Transfer Function

The customary technique for introducing hysteresis into a comparator uses positive feedback from the output back to the input. A limitation of this approach is that the amount of hysteresis varies with the output logic levels, resulting in hysteresis that can be load dependent and is not symmetrical about the threshold. The external feedback network can also introduce significant parasitics, which reduce high speed performance and can even induce oscillation in some cases.

The ADCMP572/ADCMP573 comparators offer a programmable hysteresis feature that can significantly improve the accuracy and stability of the desired hysteresis. By connecting an external pull-down resistor from the HYS pin to GND, a variable amount of hysteresis can be applied. Leaving the HYS pin disconnected disables the feature, and hysteresis is then less than 1 mV as specified. The maximum hysteresis that can be applied using this method is approximately  $\pm 25$  mV with the

pin grounded. Figure 20 illustrates the amount of hysteresis applied as a function of external resistor value. The advantages of applying hysteresis in this manner are improved accuracy, stability, and reduced component count. An external bypass capacitor is not recommended on the HYS pin because it would likely degrade the jitter performance of the device. The hysteresis pin could also be driven by a CMOS DAC. It is biased to approximately 250 mV and has an internal series resistance of 600  $\Omega$ .

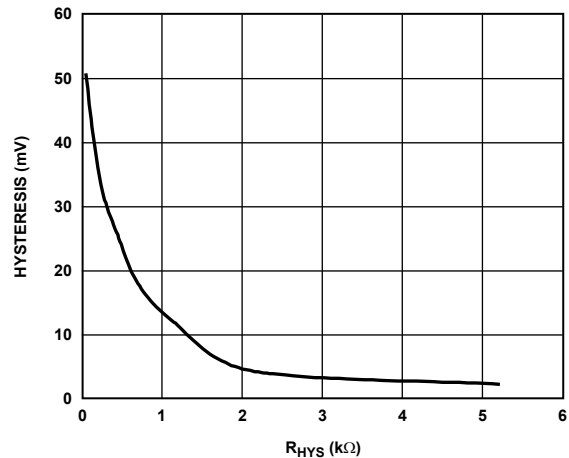

Figure 20. Hysteresis vs.  $R_{HYS}$  Control Resistor

## MINIMUM INPUT SLEW RATE REQUIREMENTS

As with all high speed comparators, a minimum slew rate requirement must be met to ensure that the device does not oscillate as the input signal crosses the threshold. This oscillation is due in part to the high input bandwidth of the comparator and the feedback parasitics inherent in the package. A minimum slew rate of 50 V/ $\mu$ s should ensure clean output transitions from the ADCMP572/ADCMP573 comparators.

The slew rate may be too slow for other reasons. The extremely high bandwidth of these devices means that broadband noise can be a significant factor when input slew rates are low. There will be at least 120  $\mu$ V of thermal noise generated over the full comparator bandwidth by two 50  $\Omega$  terminations at room temperature. With a slew rate of only 50 V/ $\mu$ s the input will be inside this noise band for over 2 ps, rendering the comparator's jitter performance of 200 fs moot. Raising the slew rate of the input signal and/or reducing the bandwidth over which this resistance is seen at the input can greatly reduce jitter.

TYPICAL APPLICATION CIRCUITS

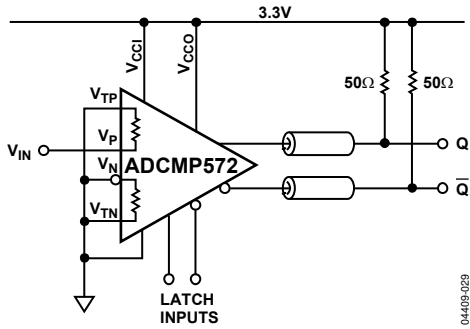

Figure 21. Zero-Crossing Detector with 3.3 V CML Outputs

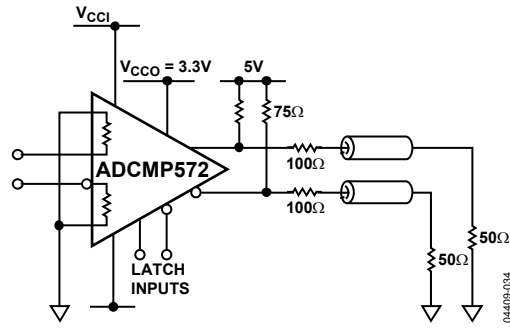

Figure 25. Interfacing 3.3 V CML to a 50 Ω Ground Terminated Instrument

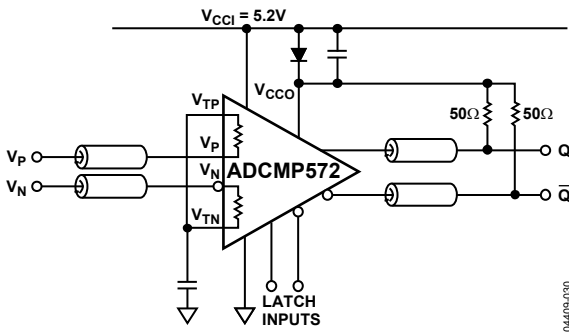

Figure 22. LVDS to 50 Ω Back Terminated RSPECL Receiver

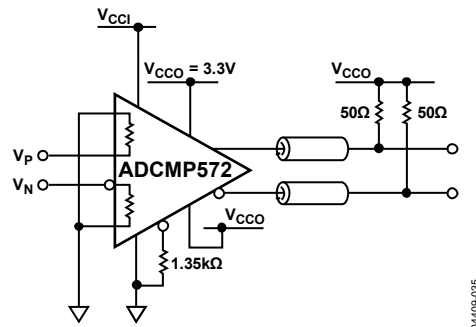

Figure 26. Disabling the ADCMP572 Latch Feature

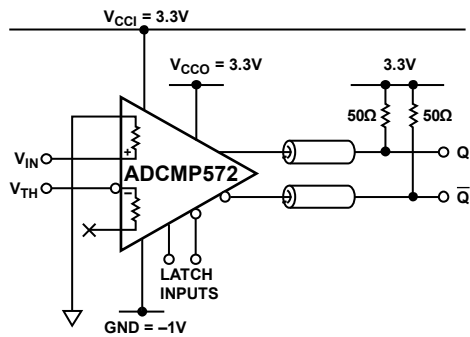

Figure 23. Comparator with ±1 V Input Range and 3.3 V CML Outputs

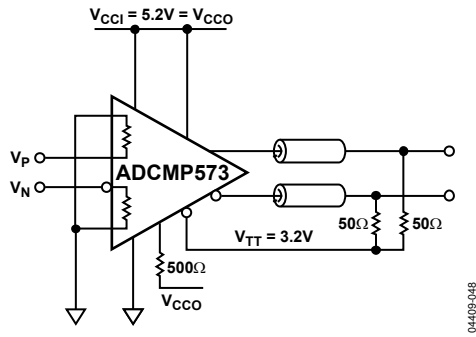

Figure 27. Disabling the ADCMP573 Latch Feature

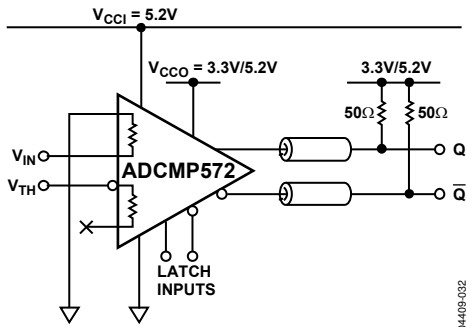

Figure 24. Comparator with 0 V to 3 V Input Range and 3.3 V or 5.2 V Positive CML Outputs

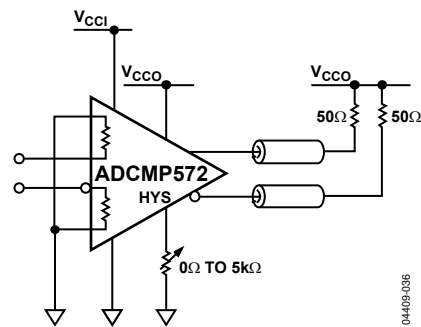

Figure 28. Adding Hysteresis Using the HYS Control Pin

### TIMING INFORMATION

Figure 29 illustrates the ADCMP572/ADCMP573 compare and latch timing relationships. Table 4 provides definitions of the terms shown in the figure.

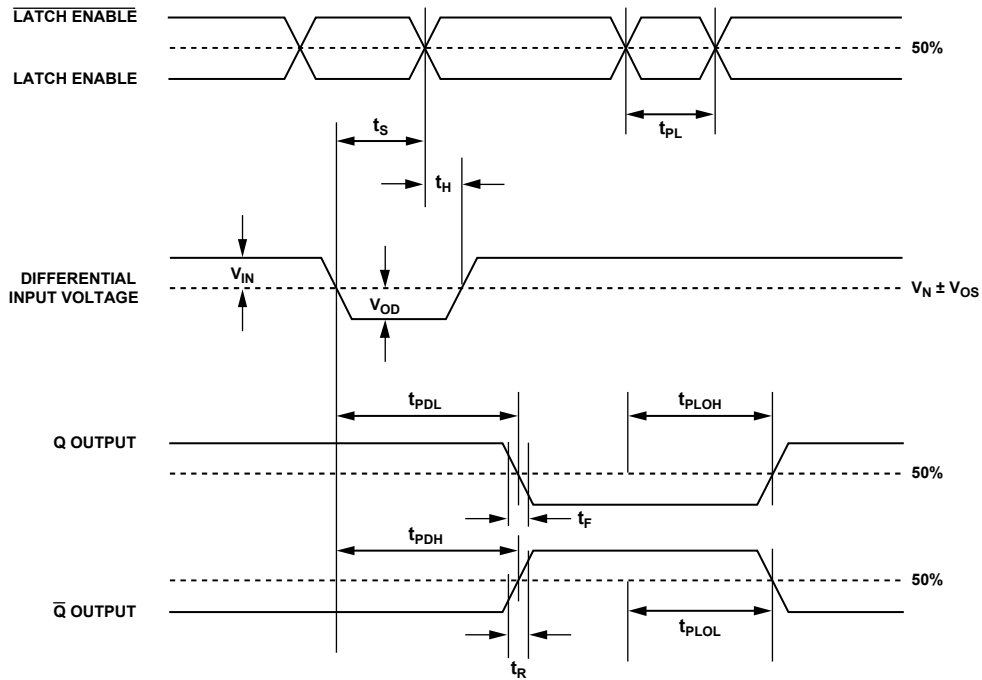

Figure 29. System Timing Diagram

04409-003

Table 4. Timing Descriptions

Symbol	Timing	Description
$t_{PDH}$	Input to output high delay	Propagation delay measured from the time the input signal crosses the reference ( $\pm$ the input offset voltage) to the 50% point of an output low-to-high transition.
$t_{PDL}$	Input to output low delay	Propagation delay measured from the time the input signal crosses the reference ( $\pm$ the input offset voltage) to the 50% point of an output high-to-low transition.
$t_{PLOH}$	Latch enable to output high delay	Propagation delay measured from the 50% point of the latch enable signal low-to-high transition to the 50% point of an output low-to-high transition.
$t_{PLOL}$	Latch enable to output low delay	Propagation delay measured from the 50% point of the latch enable signal low-to-high transition to the 50% point of an output high-to-low transition.
$t_H$	Minimum hold time	Minimum time after the negative transition of the latch enable signal that the input signal must remain unchanged to be acquired and held at the outputs.
$t_{PL}$	Minimum latch enable pulse width	Minimum time that the latch enable signal must be high to acquire an input signal change.
$t_S$	Minimum setup time	Minimum time before the negative transition of the latch enable signal that an input signal change must be present to be acquired and held at the outputs.
$t_R$	Output rise time	Amount of time required to transition from a low to a high output as measured at the 20% and 80% points.
$t_F$	Output fall time	Amount of time required to transition from a high to a low output as measured at the 20% and 80% points.
$V_{OD}$	Voltage overdrive	Difference between the input voltages $V_A$ and $V_B$ .

OUTLINE DIMENSIONS

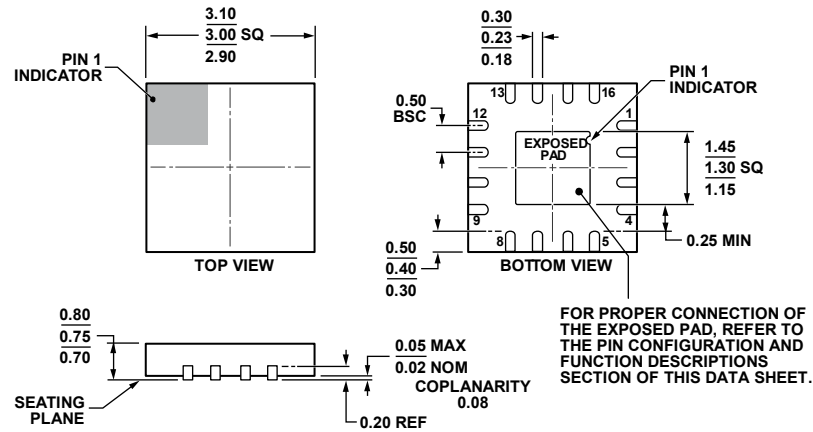

COMPLIANT TO JEDEC STANDARDS MO-220-WEED.

Figure 30. 16-Lead Lead Frame Chip Scale Package [LFCSP\_WQ]  
 3 mm x 3 mm Body, Very Very Thin Quad  
 (CP-16-21)  
 Dimensions shown in millimeters

111808-A

ORDERING GUIDE

Model <sup>1</sup>	Temperature Range	Package Description	Package Option	Branding
ADCMP572BCPZ-WP	-40°C to +125°C	16-Lead Lead Frame Chip Scale Package [LFCSP_WQ]	CP-16-21	G0Y
ADCMP572BCPZ-R2	-40°C to +125°C	16-Lead Lead Frame Chip Scale Package [LFCSP_WQ]	CP-16-21	G0Y
ADCMP572BCPZ-RL7	-40°C to +125°C	16-Lead Lead Frame Chip Scale Package [LFCSP_WQ]	CP-16-21	G0Y
EVAL-ADCMP572BCPZ		Evaluation Board		
ADCMP573BCPZ-WP	-40°C to +125°C	16-Lead Lead Frame Chip Scale Package [LFCSP_WQ]	CP-16-21	G0Z
ADCMP573BCPZ-R2	-40°C to +125°C	16-Lead Lead Frame Chip Scale Package [LFCSP_WQ]	CP-16-21	G0Z
ADCMP573BCPZ-RL7	-40°C to +125°C	16-Lead Lead Frame Chip Scale Package [LFCSP_WQ]	CP-16-21	G0Z
EVAL-ADCMP573BCPZ		Evaluation Board		

<sup>1</sup> Z = RoHS Compliant Part