

LOC		DIST		REVISIONS			
A	66	P	LTM	DESCRIPTION	DATE	OWN	APVD
		-	-	SEE SHEET 1	-	-	-

FEED TYPE MECHANICAL

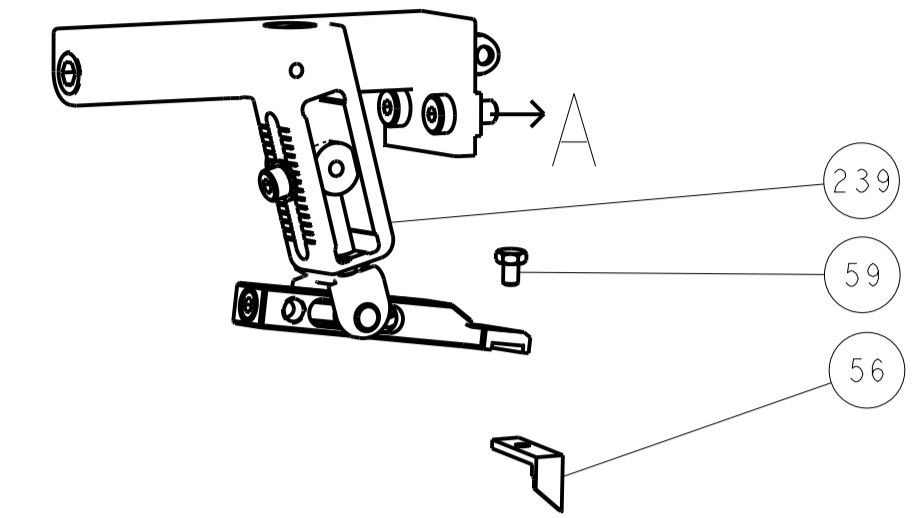

PNEUMATIC

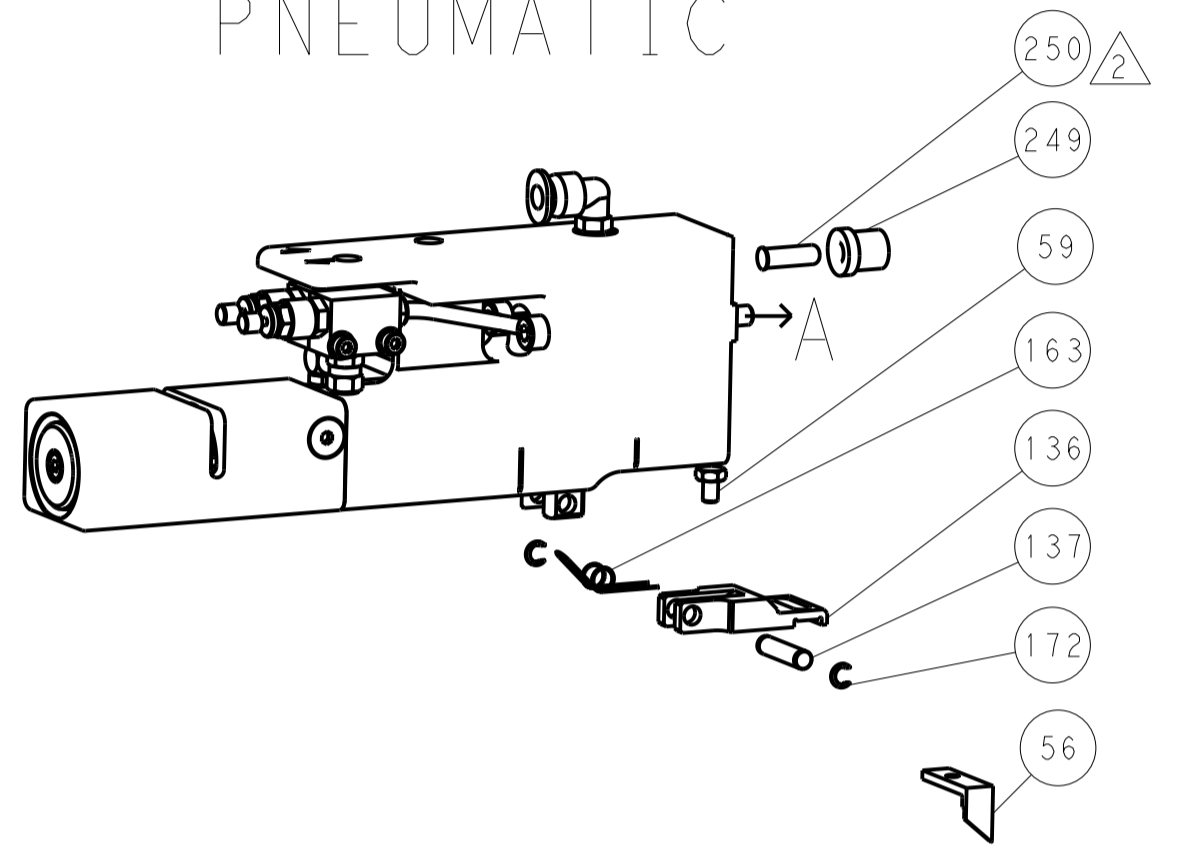

SERVO LATCH PLATE

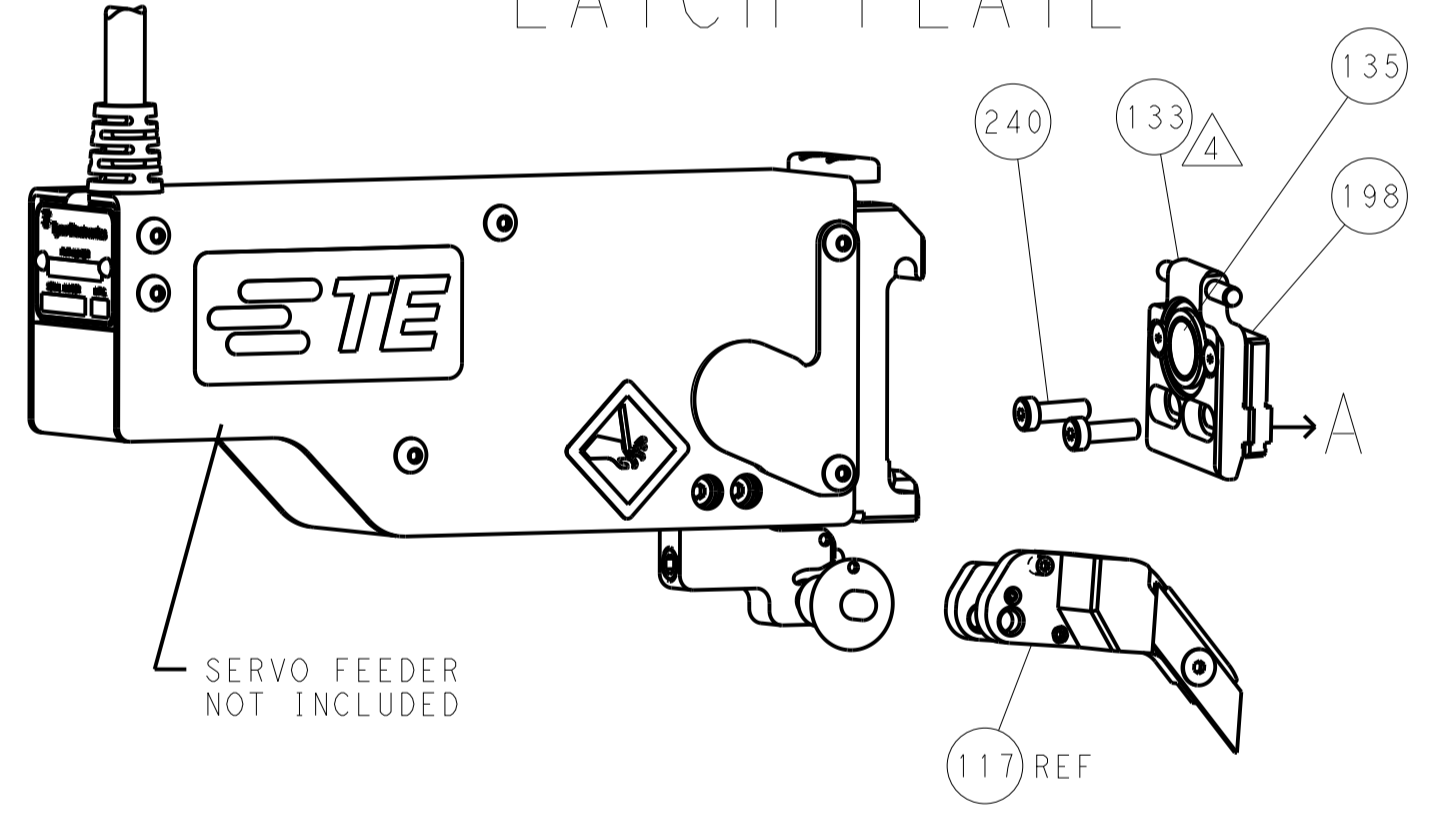

CAM POSITIONS

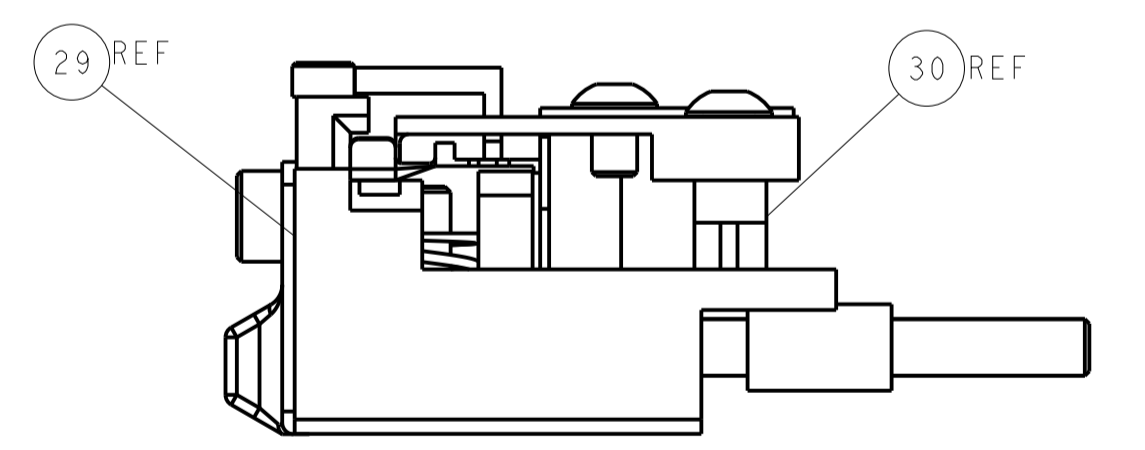
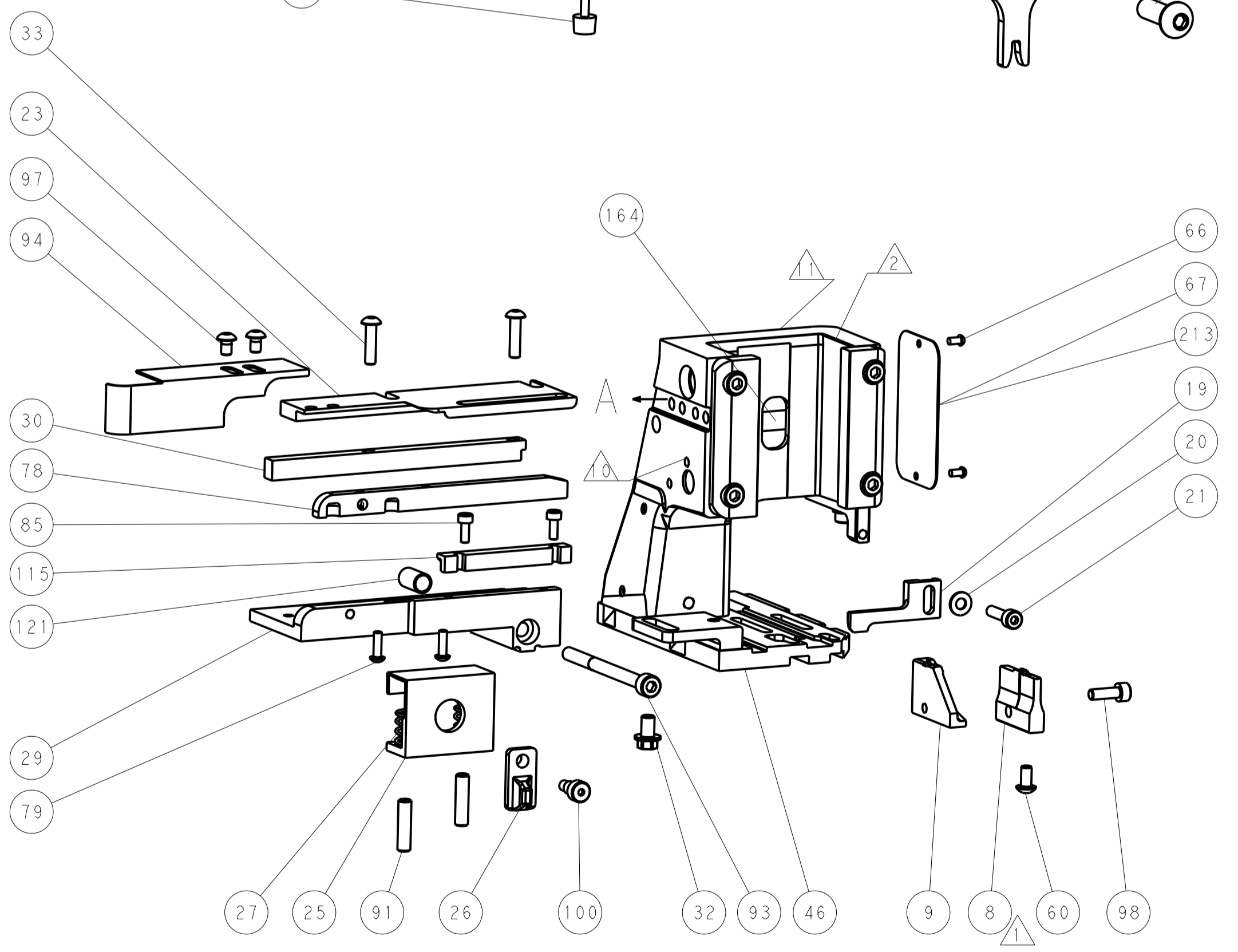
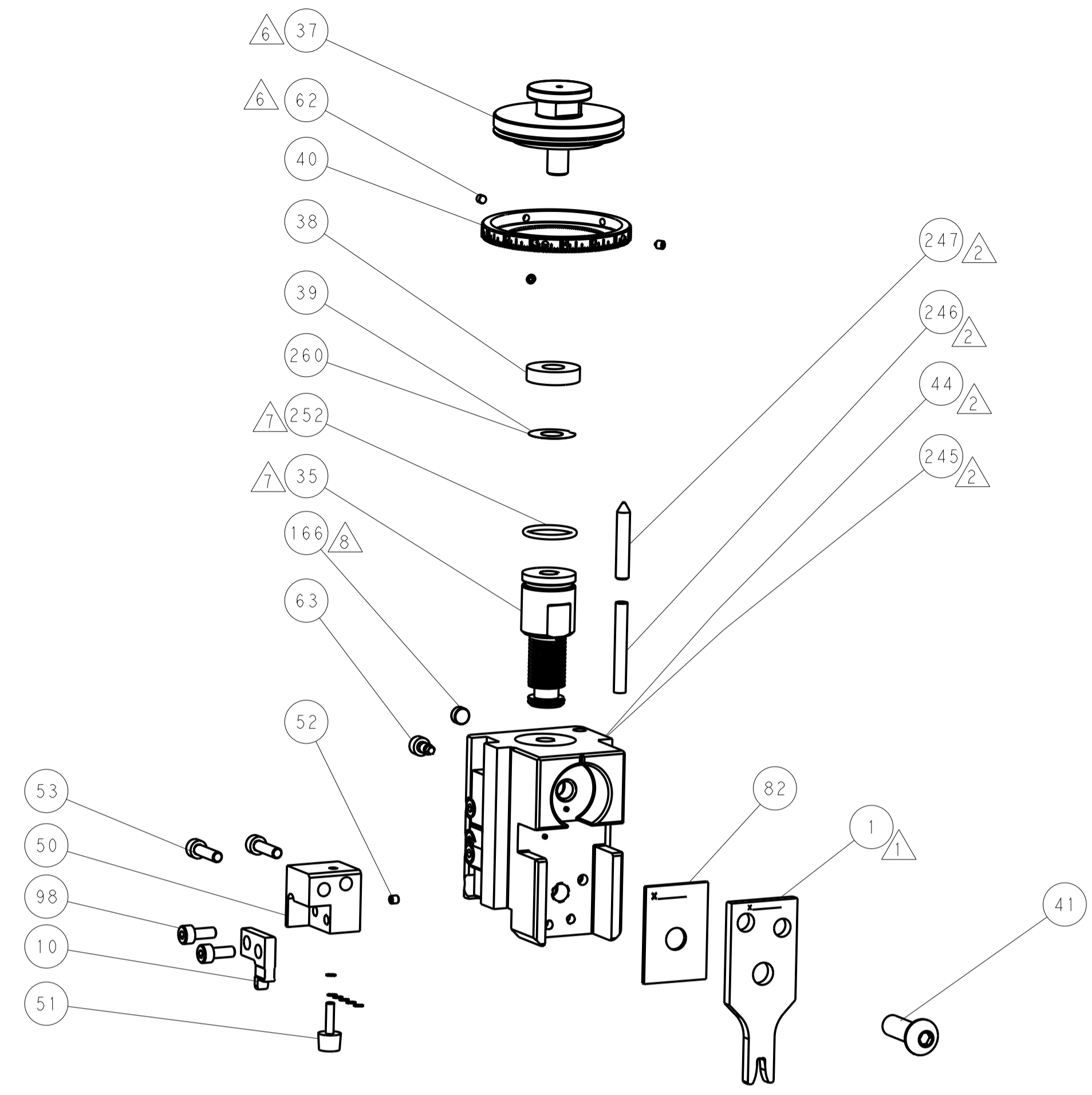
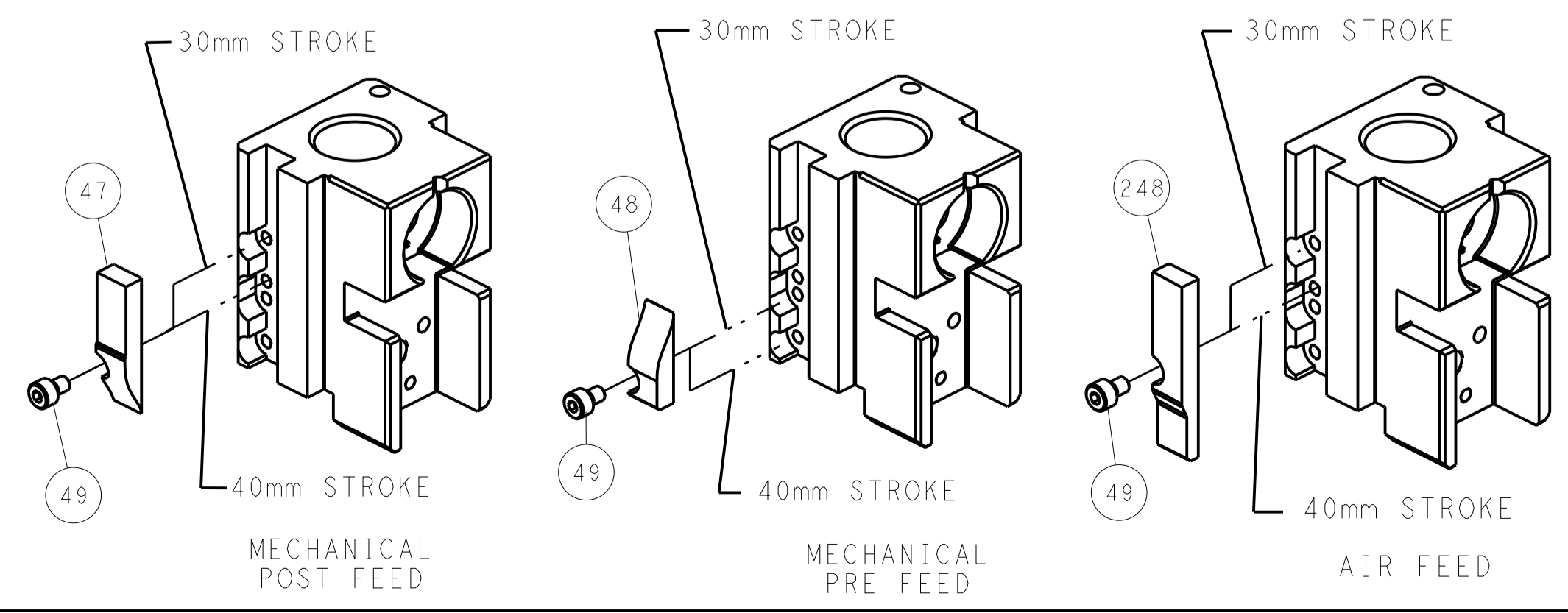

ITEM 30 LOCATED AT FRONT HOLES

FEED TRACK POSITION GUIDE BY INSULATION AND BODY

ATLANTIC VERSION
 Shown on sheets 1 of 4 & 2 of 4
 (Pacific version shown on sheets 3 of 4 & 4 of 4)

DIMENSIONS:		TOLERANCES UNLESS OTHERWISE SPECIFIED:		DWG: R. O. WILSON 16MAR2012		TE Connectivity	
mm	0 PLC ±0.5	1 PLC ±0.5	2 PLC ±0.13	3 PLC ±0.013	4 PLC ±0.0013	APVD: T. L. ELFIN 19MAR2012	Harrisburg, PA 17105-3608
MATERIAL:		FINISH:		PRODUCT SPEC:		NAME: Ocean Side Feed Applicator	
				APPLICATION SPEC:		SIZE: CAGE CODE: DRAWING NO: A1100779 ©=2151542	
				WEIGHT:		Customer Accessible Production Drawing	
				SCALE: 1:2		SHEET 2 OF 4 REV A	

LOC		DIST		REVISIONS			
A	66	P	LTH	DESCRIPTION	DATE	OWN	APVD
		-	-	SEE SHEET 1	-	-	-

FEED TYPE MECHANICAL

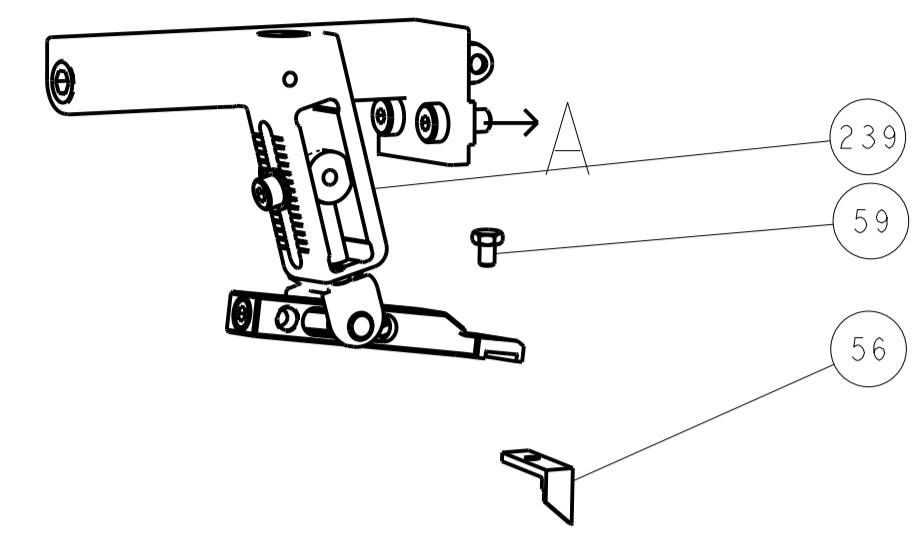

PNEUMATIC

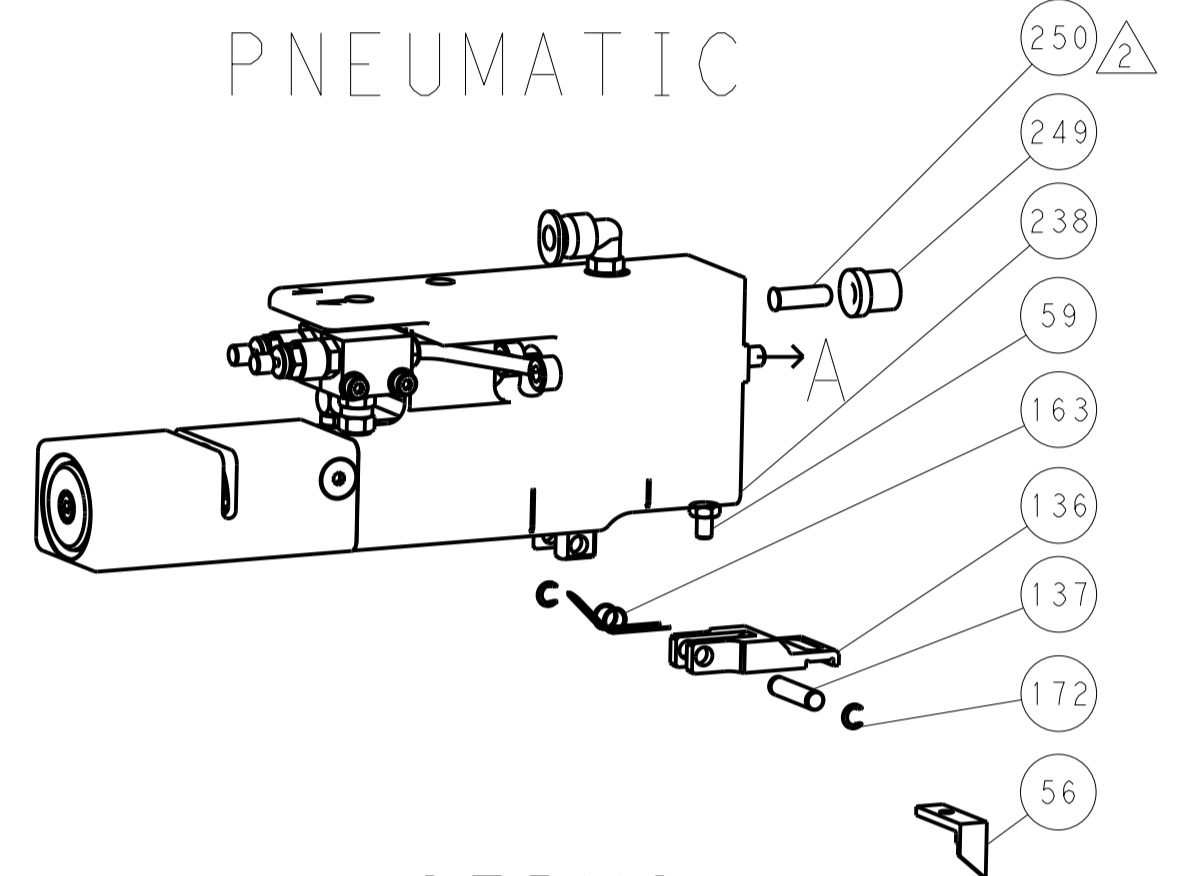

SERVO LATCH PLATE

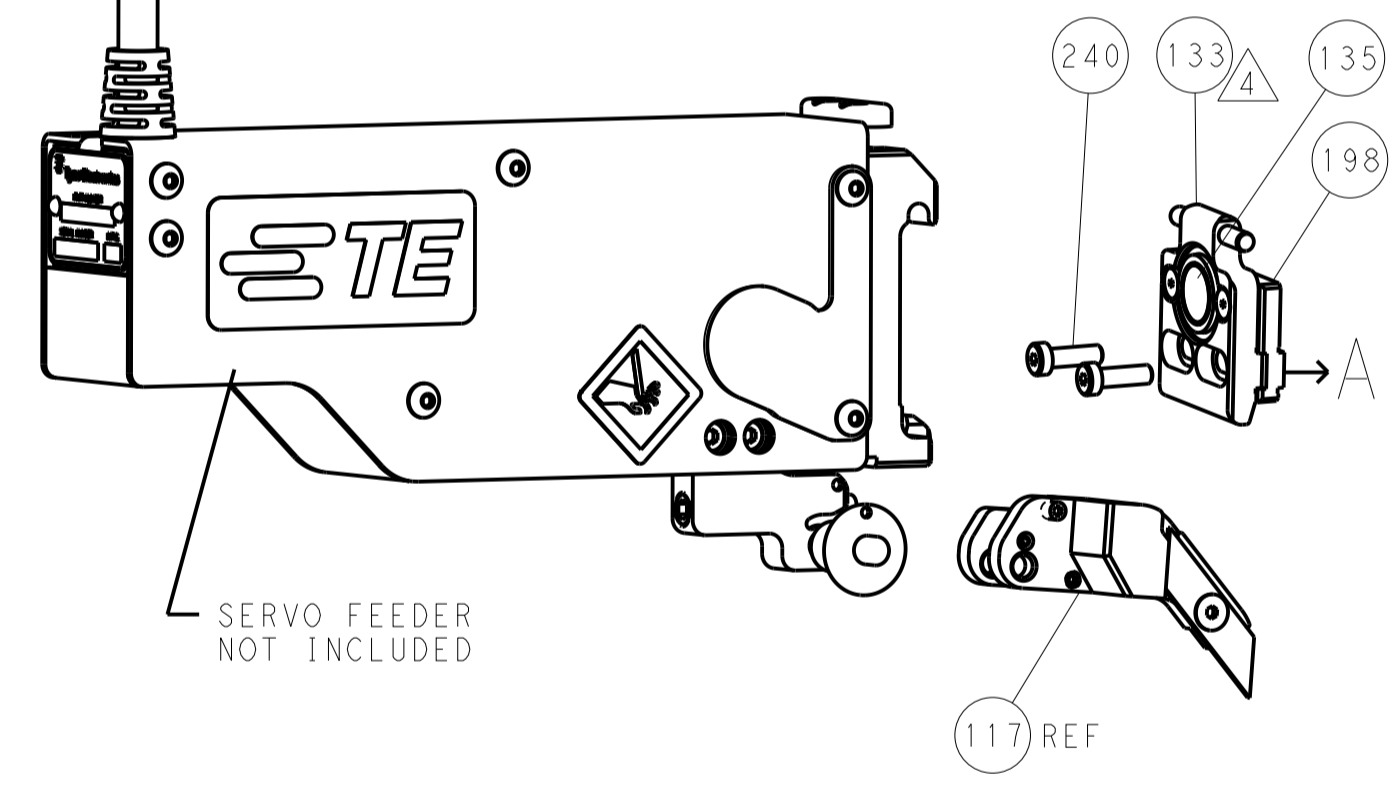

CAM POSITIONS

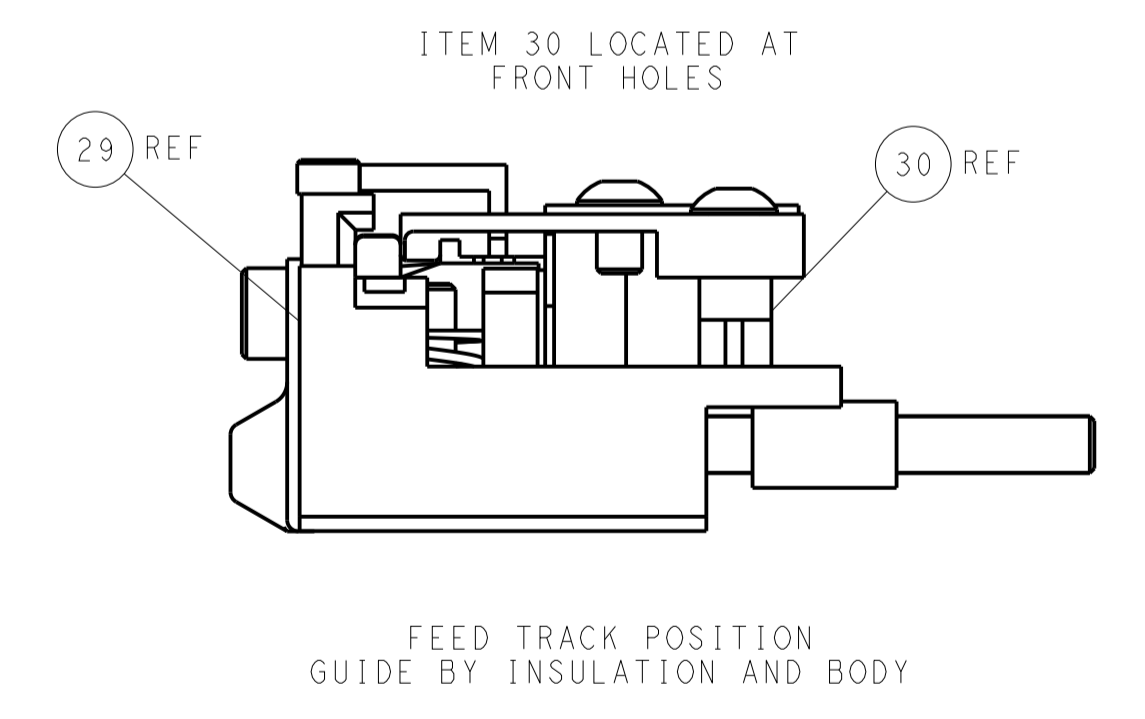
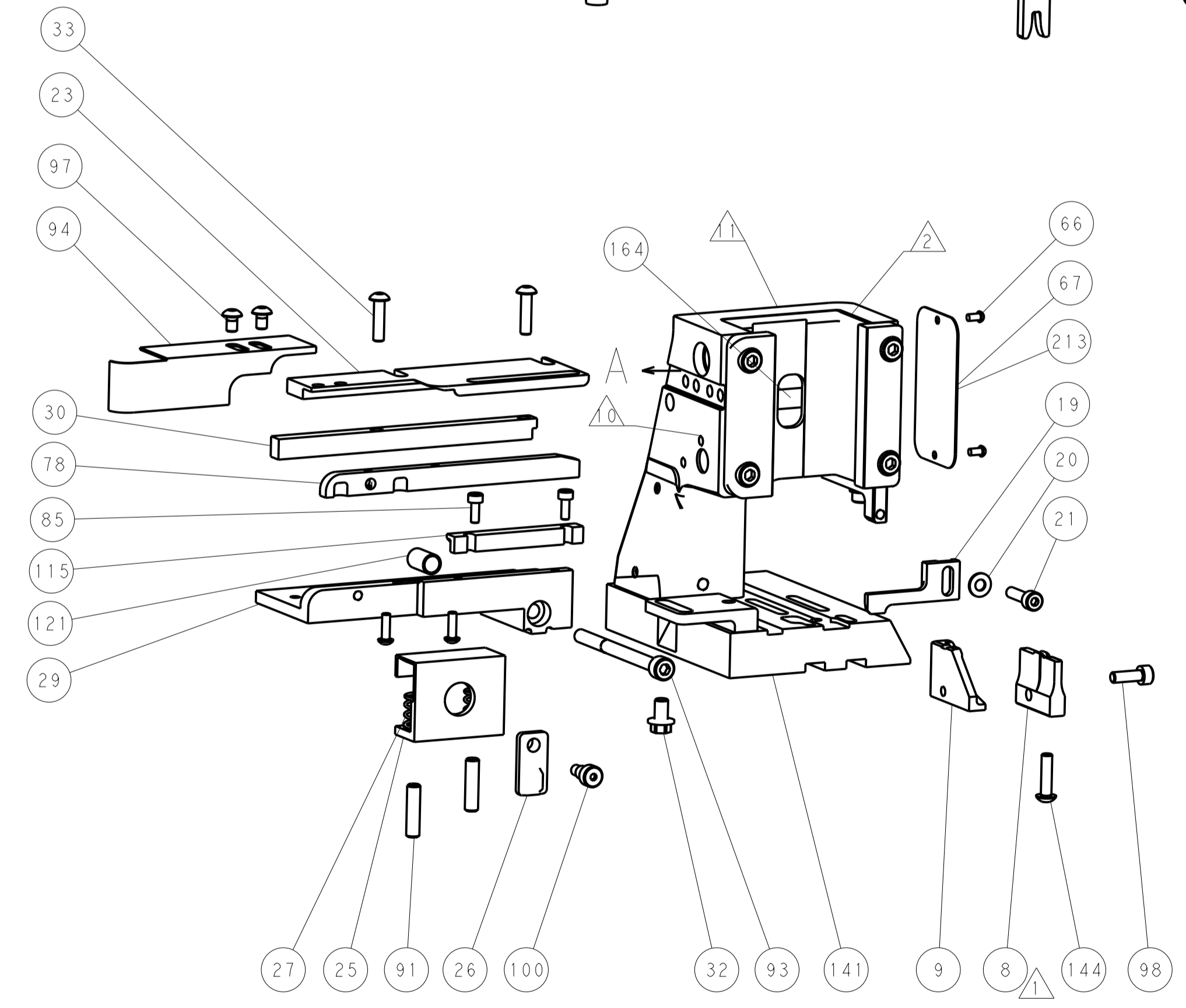
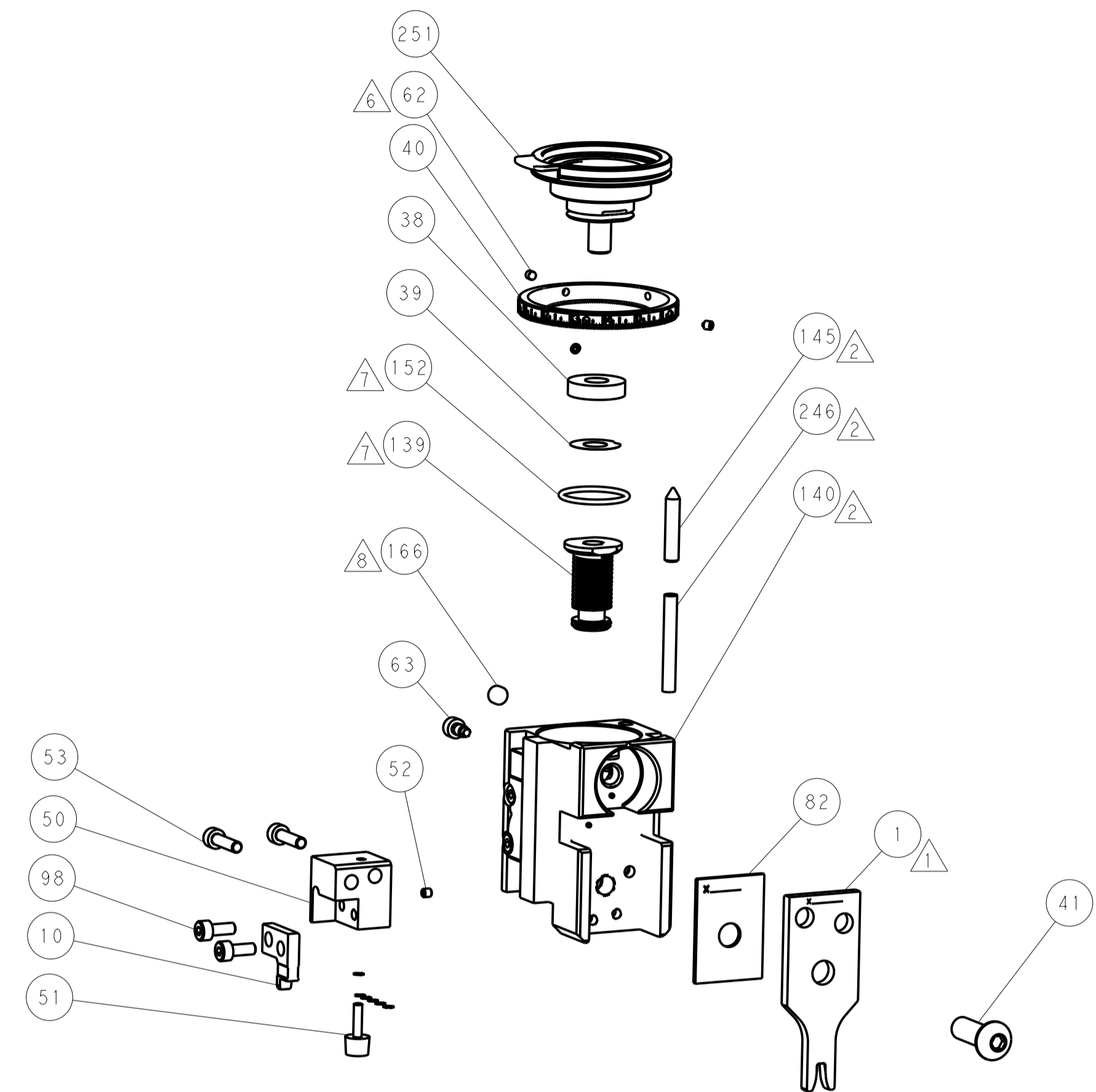
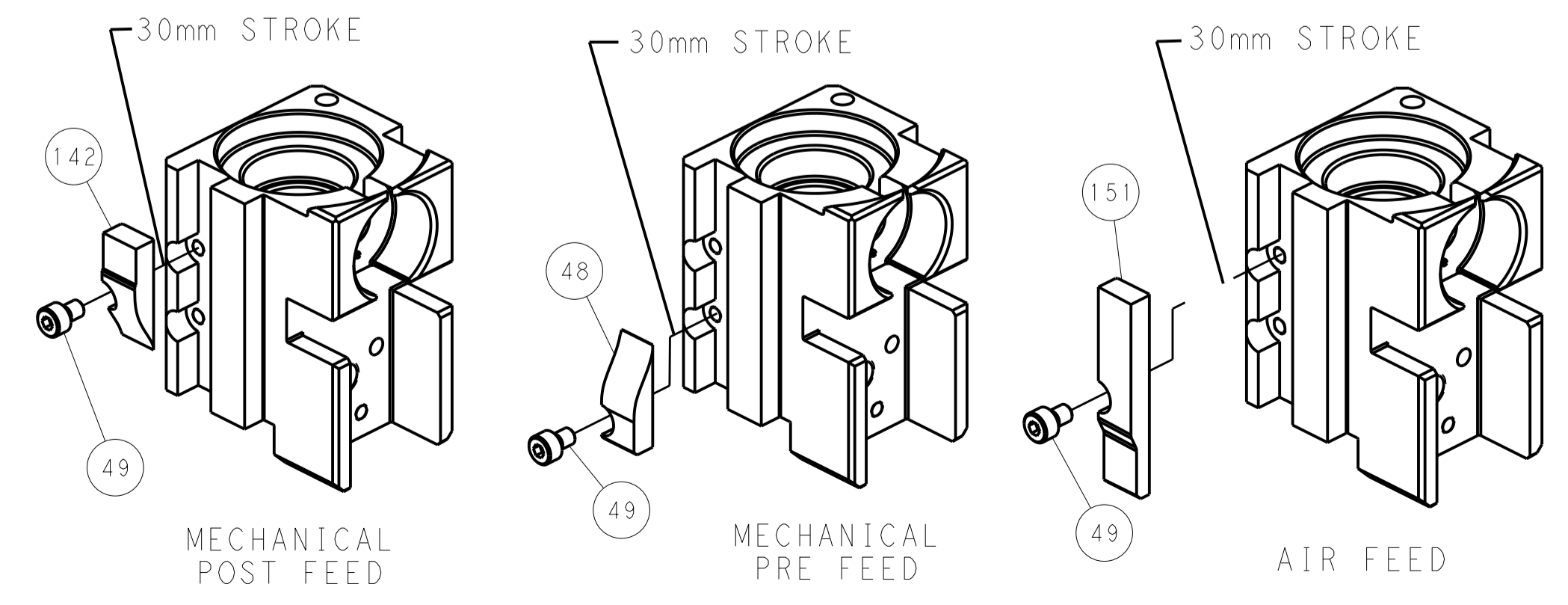

PACIFIC VERSION
 Shown on sheets 3 of 4 & 4 of 4
 (Atlantic version shown on sheets 1 of 4 & 2 of 4)

DIMENSIONS:		TOLERANCES UNLESS OTHERWISE SPECIFIED:		DWG: R.O. WILSON 16MAR2012		TE Connectivity	
mm	0 PLC ±0.5	1 PLC ±0.5	2 PLC ±0.13	3 PLC ±0.013	CHK: K.J. STAKEM 19MAR2012	Harrisburg, PA 17105-3608	
	4 PLC ±0.001	5 PLC ±0.001	6 PLC ±0.001	7 PLC ±0.001	APVD: T.L. ELFIN 19MAR2012	NAME: Ocean Side Feed Applicator	
MATERIAL:	FINISH:	WEIGHT:	SCALE:	SIZE:	CAGE CODE:	DRAWING NO:	RESTRICTED TO:
			1:2	A	00779	©=2151542	
Customer Accessible Production Drawing				SHEET 4 OF 4 REV A			