



THIS DRAWING IS A CONTROLLED DOCUMENT.

819528-1

D

C

B

A

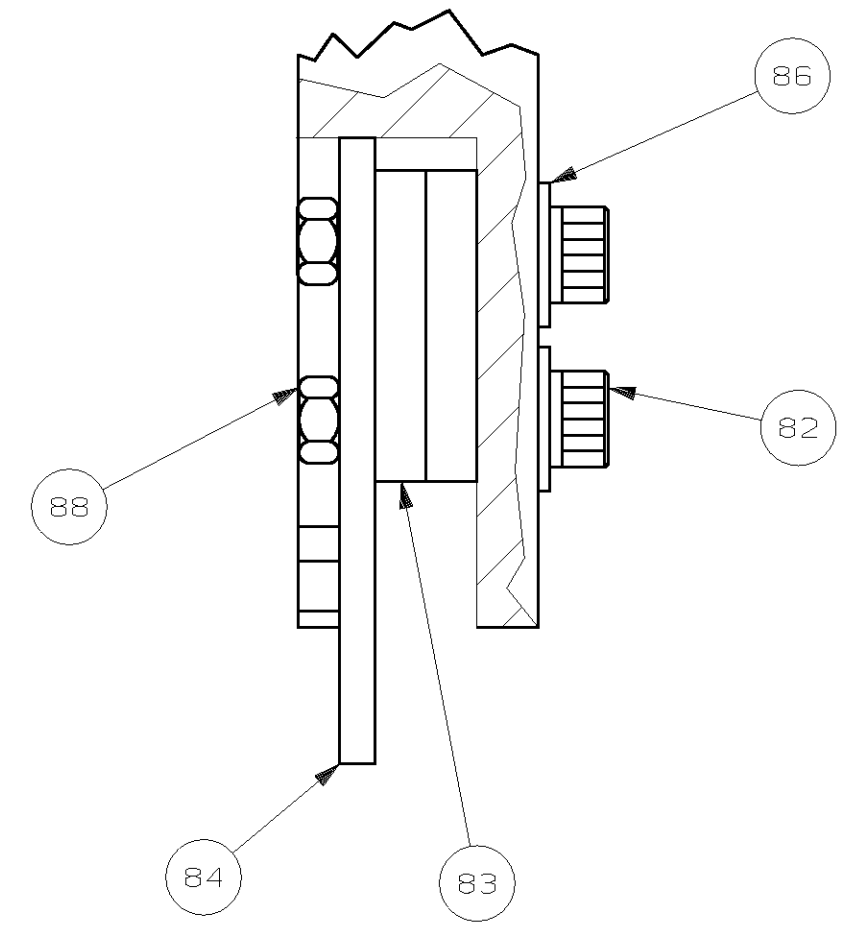

DETAIL K  
SCALE 2:1

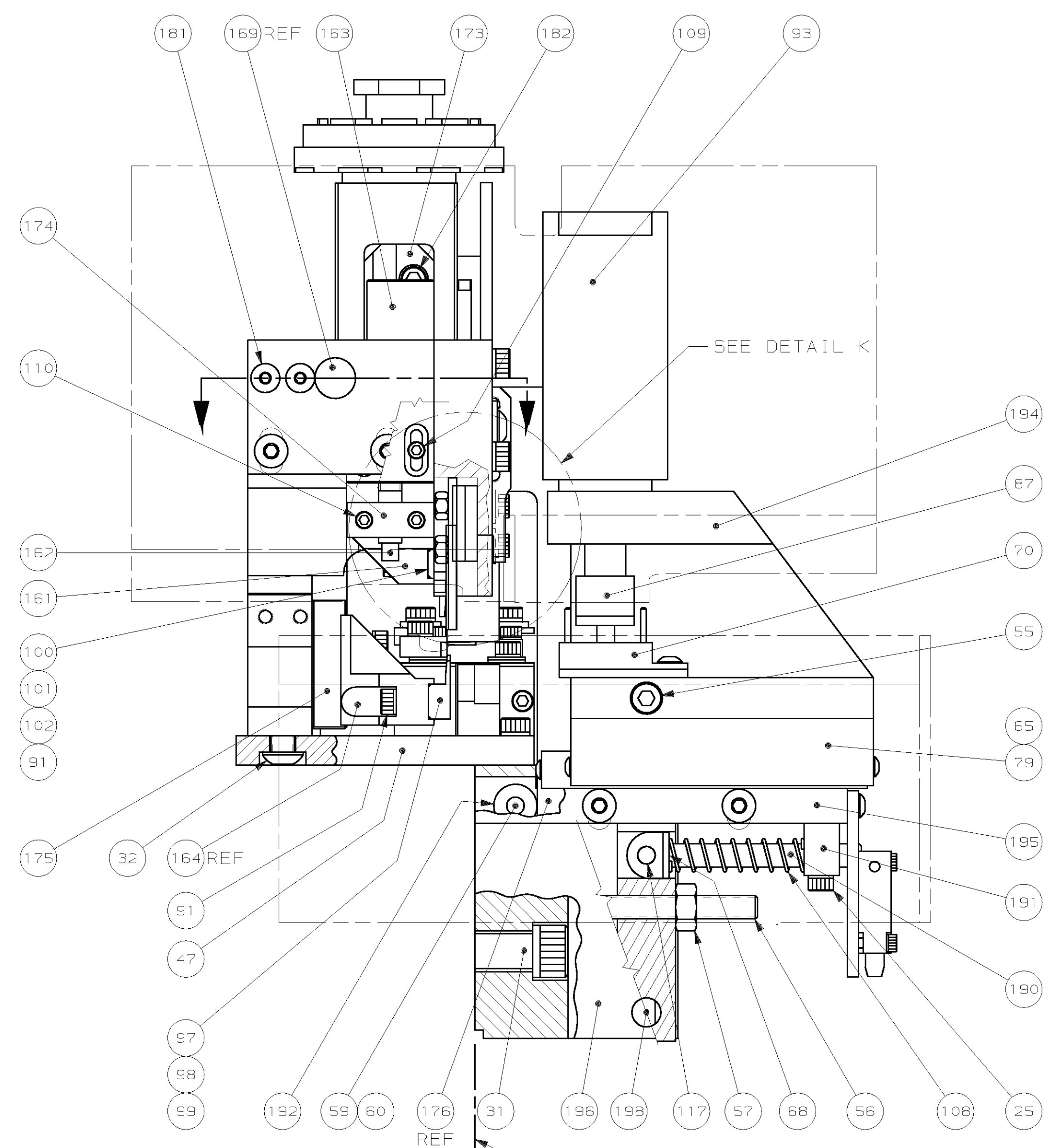
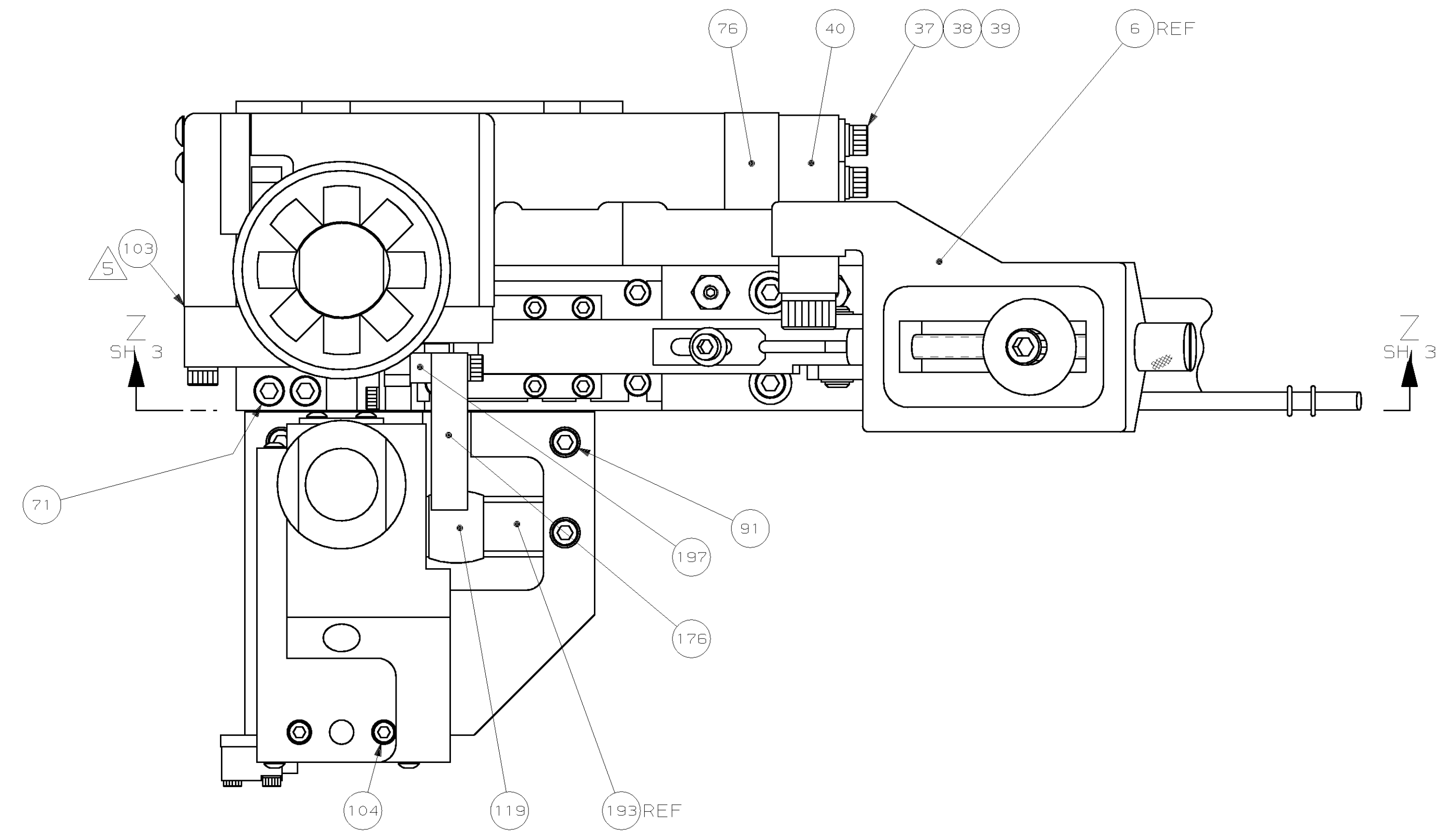
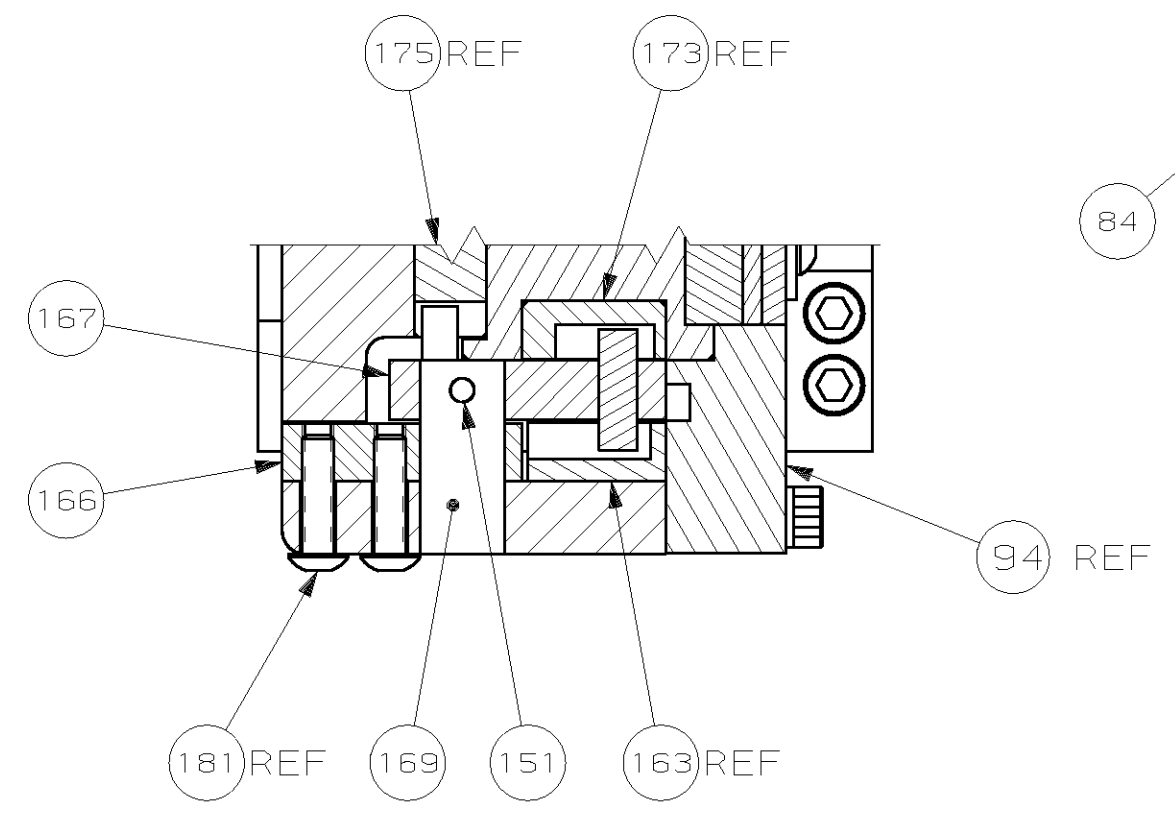

SCRAP HOLE CENTER LINE IN BENCH

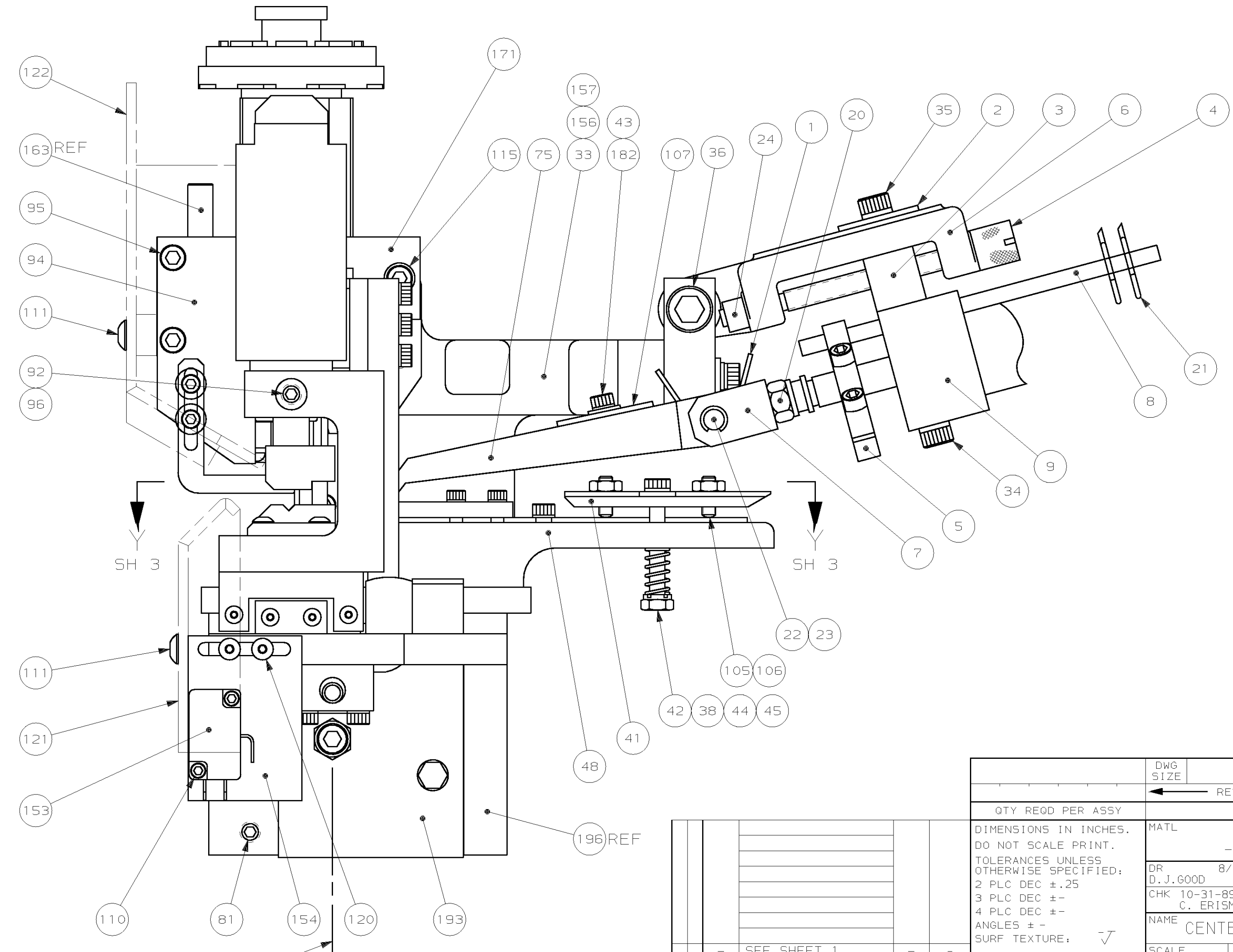

THIS DRAWING IS UNRELEASED FOR PUBLICATION BY AMP INCORPORATED. ALL RIGHTS RESERVED.

LOC A  
DIST 66

QTY	REQD	PER	ASSY	PART NO	DESCRIPTION	ITEM NO
REVISION OF EACH ASSY NO (WHEN BLANK, USE DWG REVISION)						
QTY REQD PER ASSY				PARTS LIST		
DIMENSIONS IN INCHES. DO NOT SCALE PRINT. TOLERANCES UNLESS OTHERWISE SPECIFIED:						
2 PLC DEC ± .25						
3 PLC DEC ± .1						
4 PLC DEC ± .05						
ANGLES ± -						
SURF TEXTURE: ✓						
REMOVE BURRS, BREAK SHARP EDGES .015 R MAX						
SCALE	1:1	DWG NO	819528-1	SHEET	2 OF 4	REV M3
CUSTOMER AND ASSEMBLY DRAWING 1						

REV	DATE	APP	DATE
1	8/11/89	APP	
2			
3			
4			



NAME CENTER STRIP APPLICATOR ASSEMBLY MACHINE REF CENTER STRIP MACHINE

RESTRICTED TO

THIS DRAWING IS A CONTROLLED DOCUMENT.

RELEASED FOR PUBLICATION BY AMP INCORPORATED. ALL RIGHTS RESERVED.

THIS DRAWING IS UNRELEASED. COPYRIGHT 19

LOC A  
DIST 66

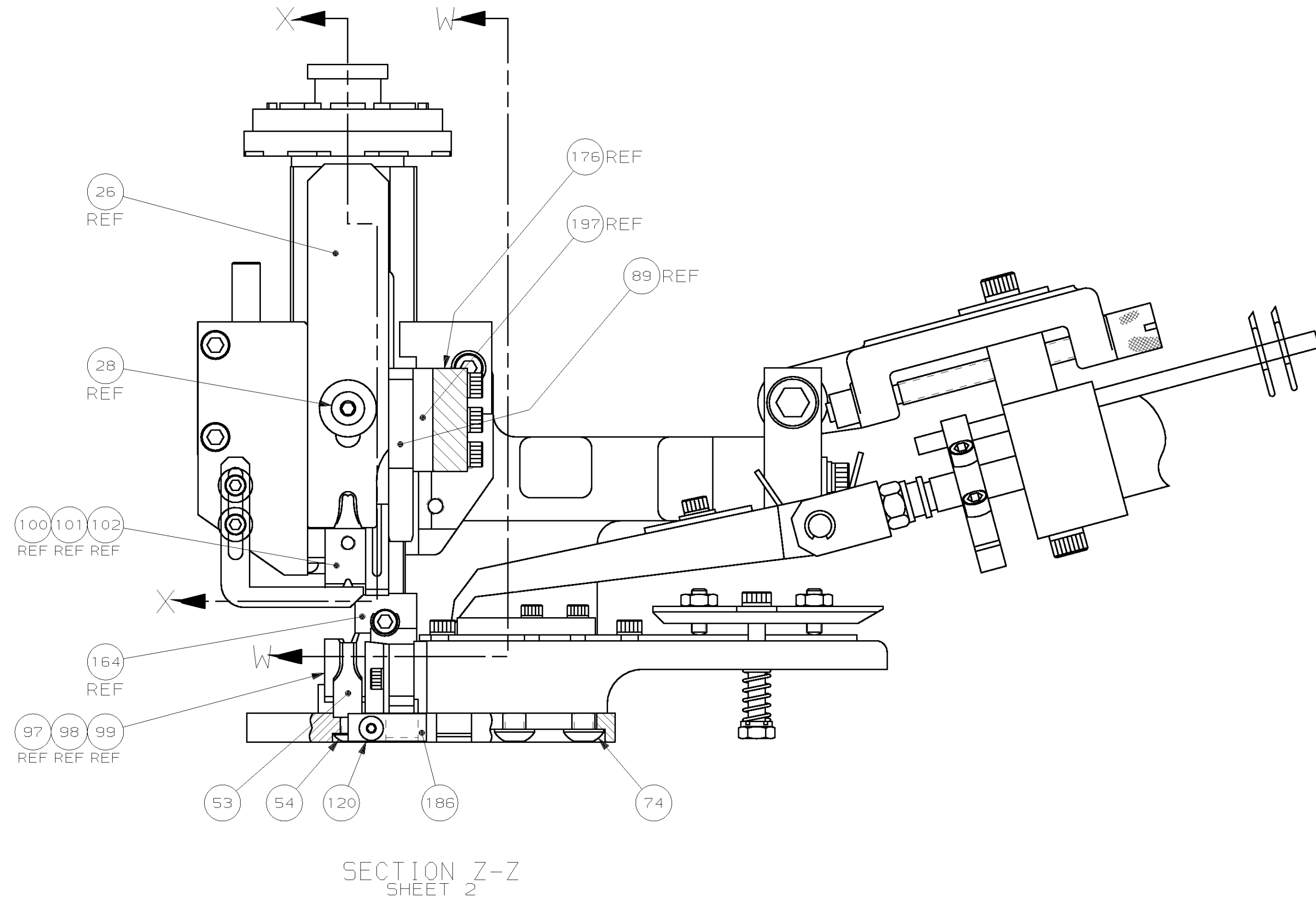
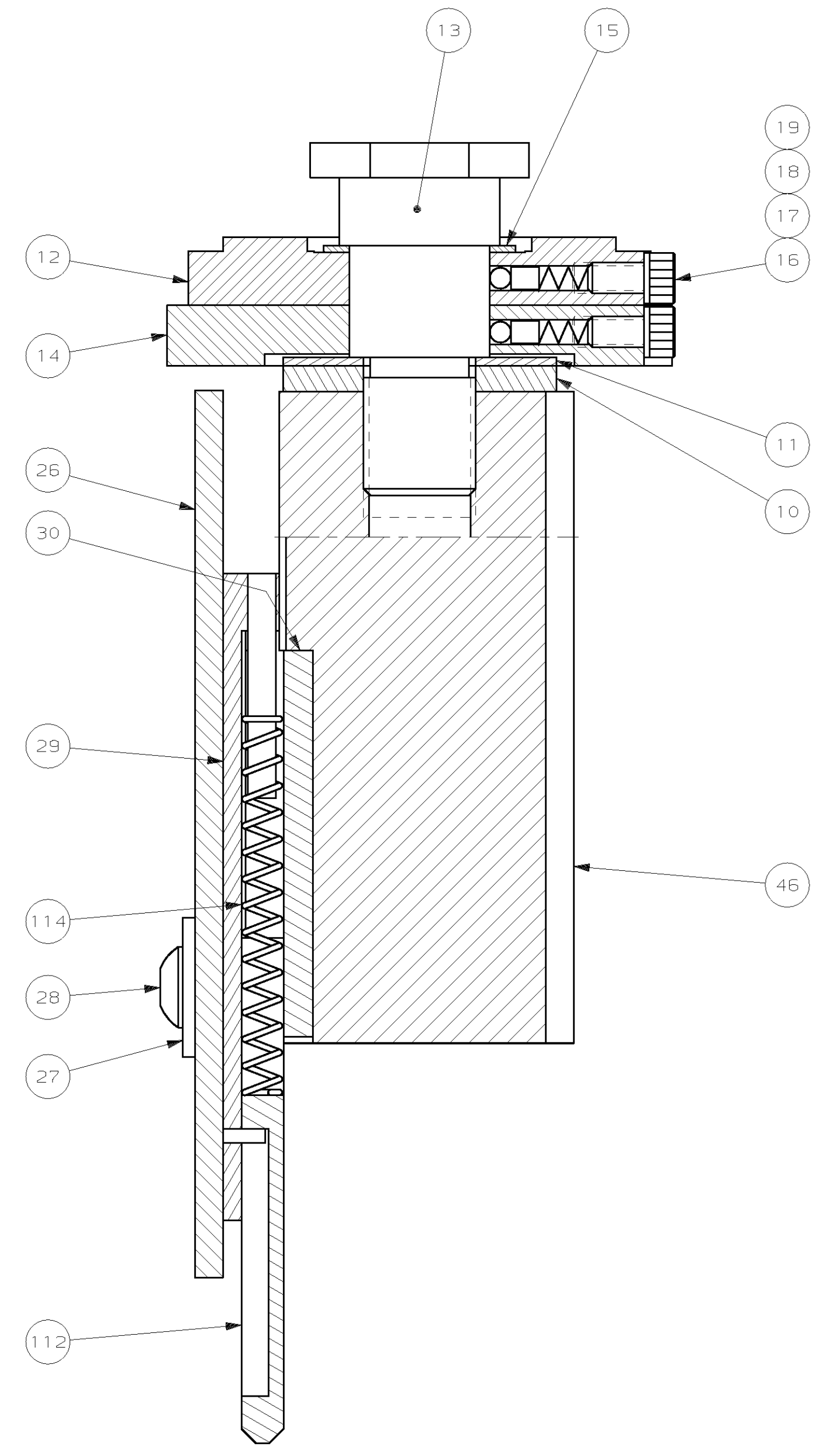
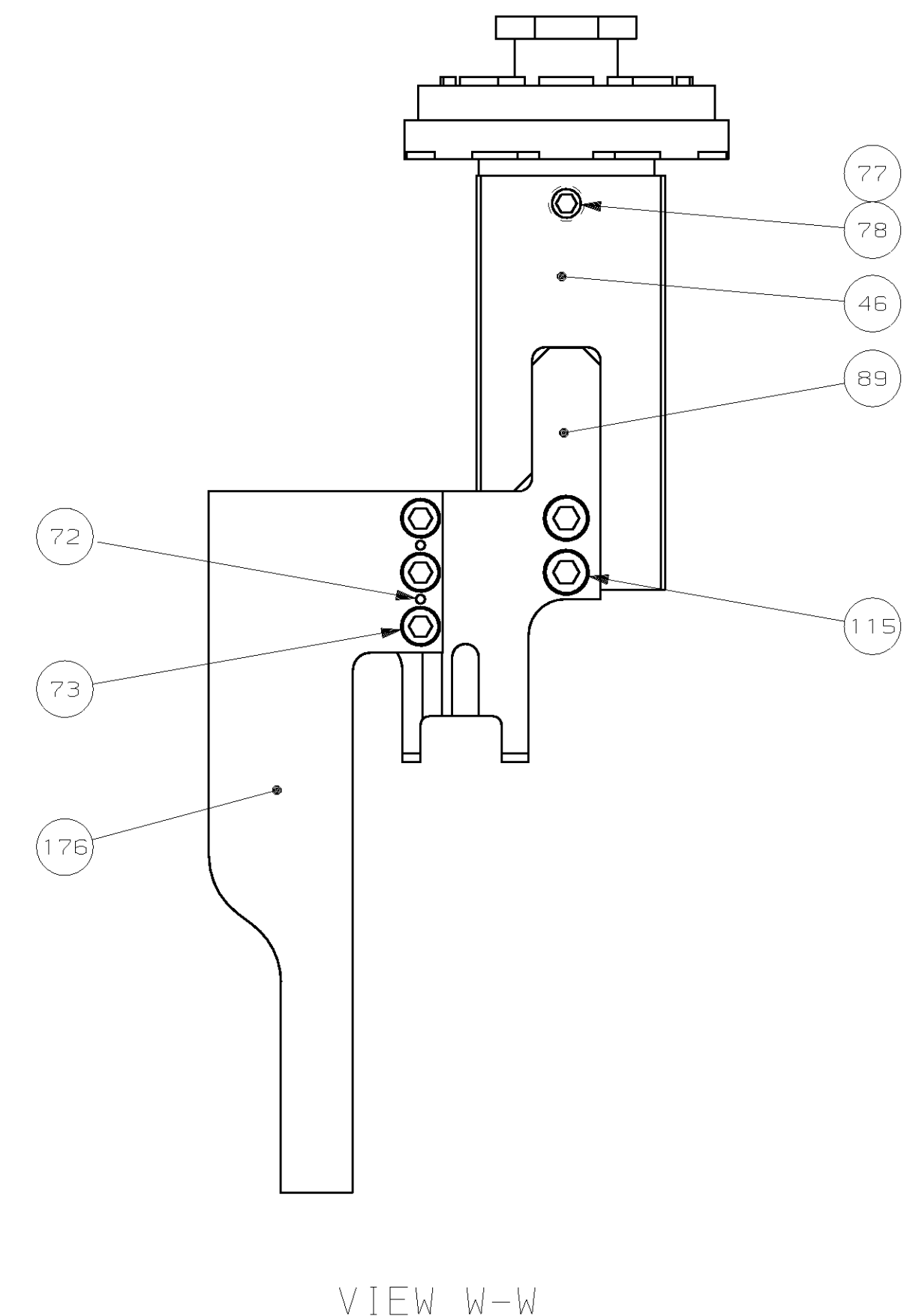
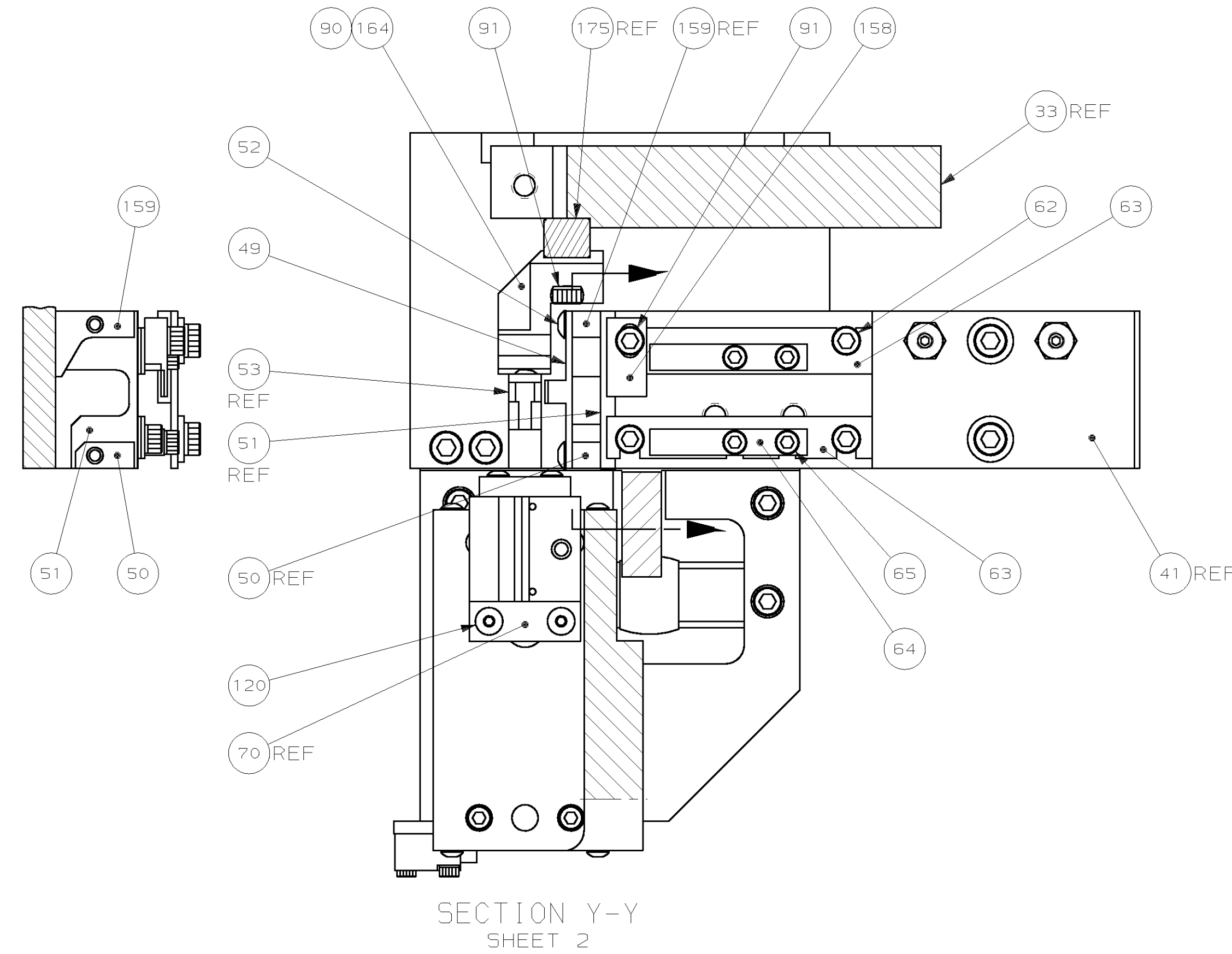

VIEW W-W

SECTION X-X SCALE 2:1

SECTION Z-Z SHEET 2

REV	DESCRIPTION	APP	DATE
1	SEE SHEET 1		
2			
3			
4			
5			
6			
7			
8			

QTY	REQD PER ASSY	PART NO	DESCRIPTION	ITEM NO
REVISION OF EACH ASSY NO (WHEN BLANK, USE DWG REVISION)				
PARTS LIST				
MATL		HT TR	FIN	
DIMENSIONS IN INCHES. DO NOT SCALE PRINT.				
TOLERANCES UNLESS OTHERWISE SPECIFIED:				
2 PLC DEC ± .25				
3 PLC DEC ±				
4 PLC DEC ±				
ANGLES ±				
SURF TEXTURE: ✓				
REMOVE BURRS, BREAK SHARP EDGES .015 R MAX				
SCALE	1:1	DWG NO	819528-1	SHEET 3 OF 4
CUSTOMER AND ASSEMBLY DRAWING 1			REV M3	RESTRICTED TO

819528-1

THIS DRAWING IS A CONTROLLED DOCUMENT.

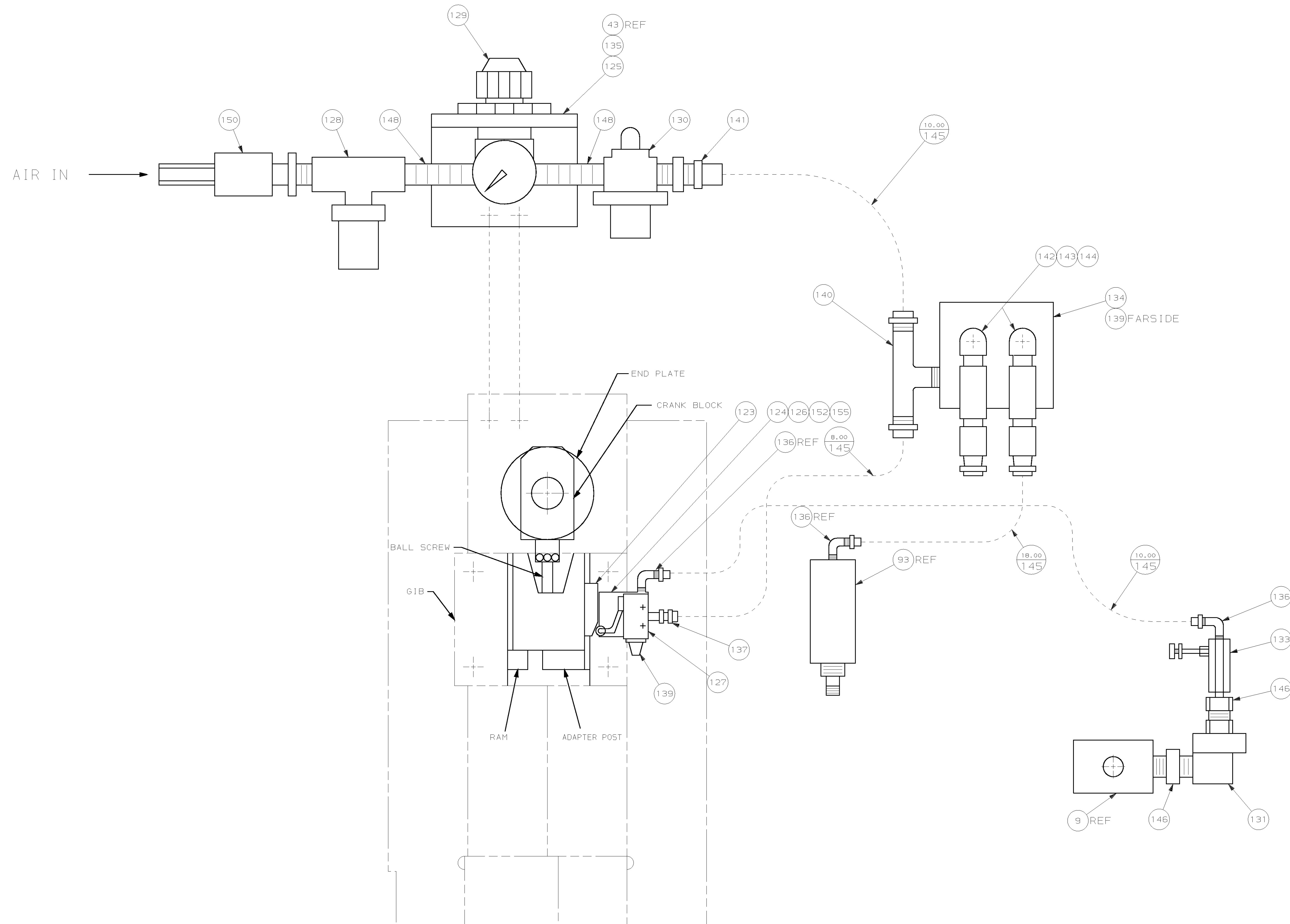

THIS DRAWING IS UNRELEASED. RELEASE FOR PUBLICATION BY AMP INCORPORATED. ALL RIGHTS RESERVED.

LOC A  
DIST 66

REV	DESCRIPTION	APP	DATE
1	SEE SHEET 1		

QTY	REQD PER ASSY	PART NO	DESCRIPTION	ITEM NO
REVISION OF EACH ASSY NO (WHEN BLANK, USE DWG REVISION)				
PARTS LIST				
DIMENSIONS IN INCHES. DO NOT SCALE PRINT.		MATL	HT TR	FIN
TOLERANCES UNLESS OTHERWISE SPECIFIED:		AMP INCORPORATED		
2 PLC DEC ± .25		Harrisburg, Pa. 17105		
3 PLC DEC ± .1		NAME		
4 PLC DEC ± .05		CENTER STRIP APPLICATOR ASSEMBLY		
ANGLES ± -		MACHINE REF		
SURF TEXTURE: ✓		CENTER STRIP MACHINE		
REMOVE BURRS, BREAK SHARP EDGES .015 R MAX		SCALE	DWG NO	SHEET REV
		1:1	819528-1	4 OF 4 M3
CASE CODE 00779		CUSTOMER AND ASSEMBLY DRAWING 1		RESTRICTED TO