

REVISIONS				
P.	LTH	DESCRIPTION	DATE	DMN APVD
F		INITIAL RELEASE	16 JAN 2014	UR SB

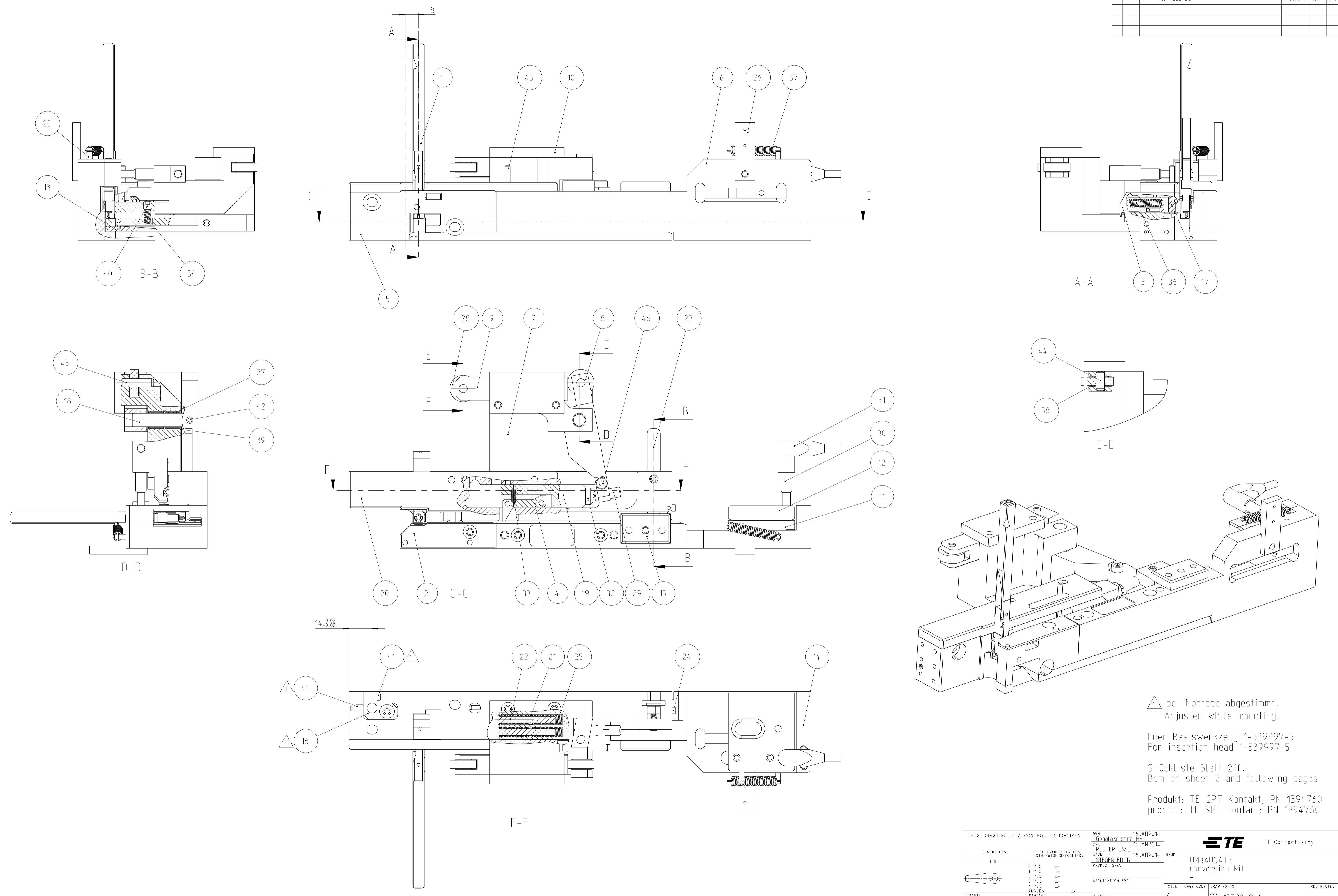

1 bei Montage abgestimmt.
 Adjusted while mounting.

 Fuer Basiswerkzeug 1-539997-5
 For insertion head 1-539997-5

 Stückliste Blatt 2ff.
 Bom on sheet 2 and following pages.

 Produkt: TE SPT Kontakt; PN 1394760
 product: TE SPT contact; PN 1394760

THIS DRAWING IS A CONTROLLED DOCUMENT.		DMN Gopalakrishna HV 16 JAN 2014	TE Connectivity	
DIMENSIONS:		CHK REUTER UWF 16 JAN 2014	NAME UMBAUSATZ conversion kit	
mm	TOLERANCES UNLESS OTHERWISE SPECIFIED:	APVD SIEGFRIED B 16 JAN 2014	PRODUCT SPEC	
 	0 PLC # # # # 1 PLC # # # # 2 PLC # # # # 3 PLC # # # # 4 PLC # # # # ANGLES # # # #	APPLICATION SPEC	SIZE A1	
MATERIAL	FINISH	WEIGHT	CAGE CODE C=1372069-6	DRAWING NO
-	-	-	Customer Drawing	SCALE 1:1 SHEET 1 OF 3 REV F

REVISIONS				
P.	LTN	DESCRIPTION	DATE	APVD
-		SEE SHEET 1	-	-

POS	QTY	TE/PN	PART REV	DESCRIPTION	WEAR	SPARE
1	1	8-539496-2	C	SETZFINGER KOMPLETT insertion finger complete	YES	YES
2	1	7-1372348-8	D	SCHNITTPLATTE cutting plate	YES	YES
3	1	7-1372348-7	D	SCHNITTMESSER cutting blade	YES	YES
4	1	8-1372348-6	B	VORSCHUBFINGER FEEDING FINGER	YES	YES
5	1	7-1372348-5	C	WERKZEUGBASIS tool base	-	-
6	1	7-1372348-6	B	FUEHRUNG VORNE guiding front	-	-
7	1	8-1372348-1	B	HALTER HOLDER	-	-
8	1	8-1372348-2	B	HEBEL LEVER	-	-
9	1	8-1372348-8	B	STOESSEL ram	-	-
10	1	9-1372348-0	B	DECKEL cover	-	-
11	1	8-1372348-4	B	SPLICEERKENNUNG INNEN splice detection inside	-	-
12	1	8-1372348-3	B	SPLICEERKENNUNG AUSSEN splice detection outside	-	-
13	1	8-1372348-9	B	BREMSE BRAKE	-	-
14	1	8-1372348-5	B	DECKEL cover	-	-
15	1	6-1372207-2	B	NIEDERHALTER downholder	-	-
16	1	2-1372481-2	A	ABSTIMMKLOTZ ADJUSTING BLOCK	-	-
17	1	9-1372348-1	B	ZENTRIERSTEMPEL centering punch	-	-
18	1	6-1372234-3	B	Achse axis	-	-
19	1	8-1372348-0	B	TRANSPORTSCHIEBER transport slider	-	-
20	1	7-1372348-9	C	DECKEL cover	-	-
21	2	6-1372316-1	B	HUELSE sleeve	-	-
22	2	7-1372328-5	B	FEDERBOLZEN spring bolt	-	-
23	1	3-1372269-2	B	HEBEL lever	-	-
24	1	6-539939-7	B	BOLZEN BOLT	-	-
25	2	2-1372209-1	B	STIFT pin	-	-
26	1	4-1372234-1	B	Halter holder	-	-

27	2	506344-6	A	NADELHÜLSE NEEDLE SLEEVE	-	YES
28	2	516403-1	A	FLOW ROLLER LAUFROLL	-	YES
29	1	511591-8	A	KUGELDRUCKSCHRAUBE M6*16 -	-	YES
30	1	4-523159-7	A	Initiator sensor	-	YES
31	1	2030564-1	A	CABLE, CONNECTING.METAL COUPLING, ANGLE -	-	YES
32	1	506797-1	A	BOLT NORELEM: 02010-061	-	YES
33	1	6-510500-5	A	Druckfeder PRESSURE SPRING	-	YES
34	1	9-510500-4	A	Druckfeder PRESSURE SPRING	-	YES
35	4	9-653861-3	E	Druckfeder PRESSURE SPRING	-	YES
36	1	2-659650-9	A	Druckfeder Compression Spring	-	YES
37	1	9-653860-9	A	Zugfeder TENSION SPRING	-	YES
38	4	519037-3	A	Passscheibe 5x10x0.5 DIN 988 -	-	YES
39	2	519037-6	A	Passscheibe 8x14x0.5 DIN 988 -	-	YES
40	1	3-519011-5	B	SCREW M5x5 DIN 913 -	-	YES
41	2	3-519011-0	B	SCREW M4x8 DIN 913 -	-	YES
42	1	3-519011-6	B	SCREW M5x6 DIN 913 -	-	YES
43	1	4-519051-2	A	ZYL.-STIFT 3M6*36 DIN 6325-ST -	-	YES
44	1	6-519051-3	A	Zyl.-Stift 5m6x12 DIN 6325 -	-	YES
45	1	6-519051-7	A	Zyl.-Stift 5m6x20 DIN 6325 -	-	YES
46	1	2-519000-3	A	Zylinderschr. M4x16 DIN 912 -	-	YES

DIMENSIONS:		TOLERANCES UNLESS OTHERWISE SPECIFIED:		APVD		NAME	
mm		0 PLC	±	16 JAN 2014		UMBAUSATZ conversion kit	
		1 PLC	±	16 JAN 2014		-	
		2 PLC	±	16 JAN 2014		-	
		3 PLC	±	16 JAN 2014		-	
		4 PLC	±	16 JAN 2014		-	
		ANGLES	±	16 JAN 2014		-	
		FINISH	±	16 JAN 2014		-	
MATERIAL				Customer Drawing		RESTRICTED TO	
				SCALE 1:1		SHEET 2 OF 3	
				REV F			

REVISIONS					
P.	LTN	DESCRIPTION	DATE	DMN	APVD
-	-	SEE SHEET 1	-	-	-

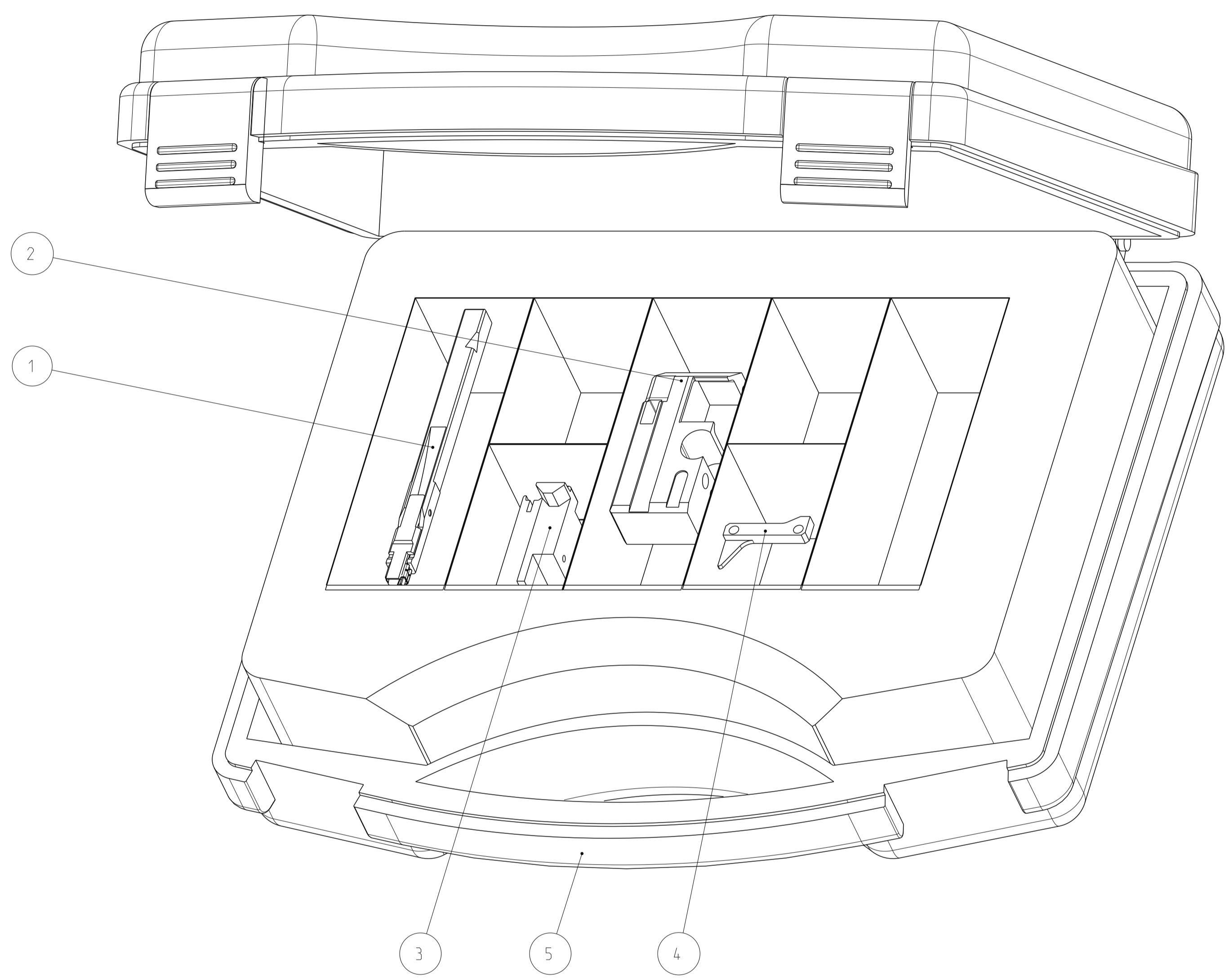

TOOL KIT 1372089-6
 SHOWN

POS	QTY	TE/PN	PART REV	DESCRIPTION	WEAR	SPARE
1	1	8-539496-2	C	SETZFINGER KOMPLETT insertion finger complete	YES	YES
2	1	7-1372348-8	D	SCHNITTPLATTE cutting plate	YES	YES
3	1	7-1372348-7	D	SCHNITTMESSER cutting blade	YES	YES
4	1	8-1372348-6	B	VORSCHUBFINGER FEEDING FINGER	YES	YES
5	1	539383-5	B	SUIT CASE ERSATZTEILKOFFER	-	-

THIS DRAWING IS A CONTROLLED DOCUMENT.		DMN Gopalakrishna HV 16 JAN 2014	 TE Connectivity
DIMENSIONS: mm		CHK REUTER UWF 16 JAN 2014	
TOLERANCES UNLESS OTHERWISE SPECIFIED:		APVD STIEGRIED B 16 JAN 2014	NAME UMBAUSATZ conversion kit
0 PLC ± 1 PLC ± 2 PLC ± 3 PLC ± 4 PLC ± ANGLES ± FINISH ±		PRODUCT SPEC - APPLICATION SPEC -	SIZE A1
MATERIAL - -		WEIGHT - -	RESTRICTED TO - -
Customer Drawing		SCALE 1:1	SHEET 3 OF 3
		REV F	