

REVISIONS					
P	LTR	DESCRIPTION	DATE	DMN	APVD
U		REV PER ECO 19-019228	4-17-20	CT	DM

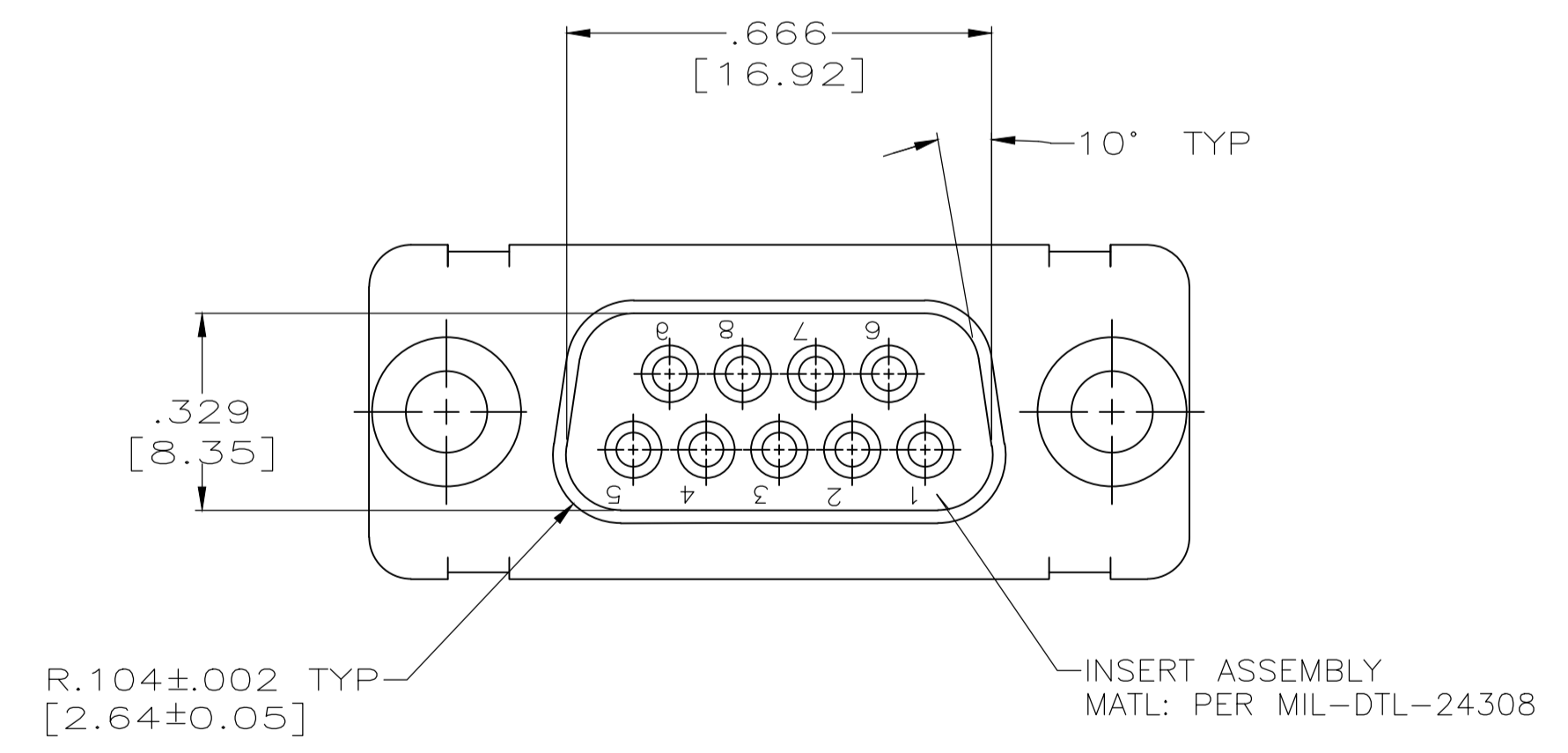
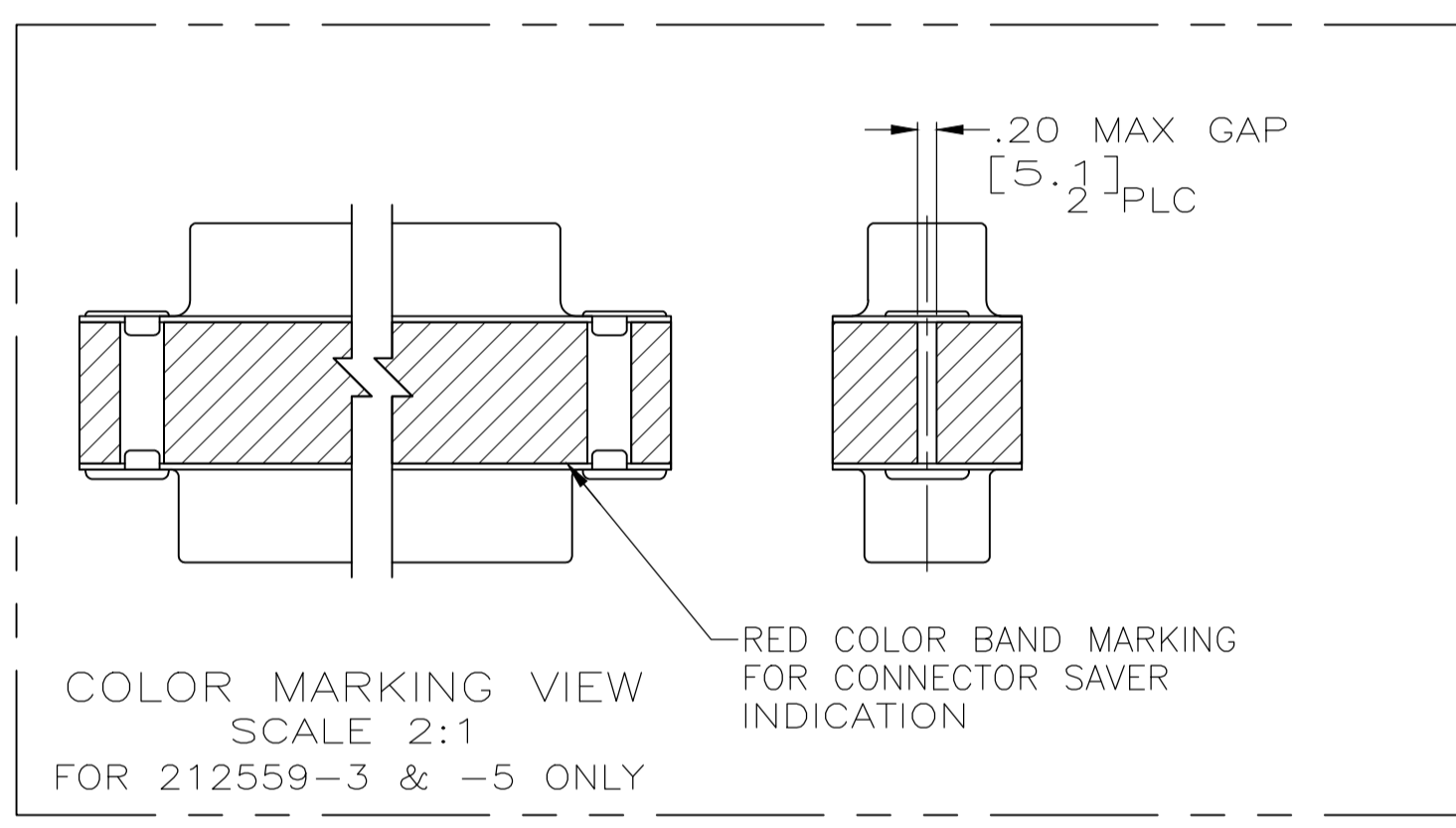
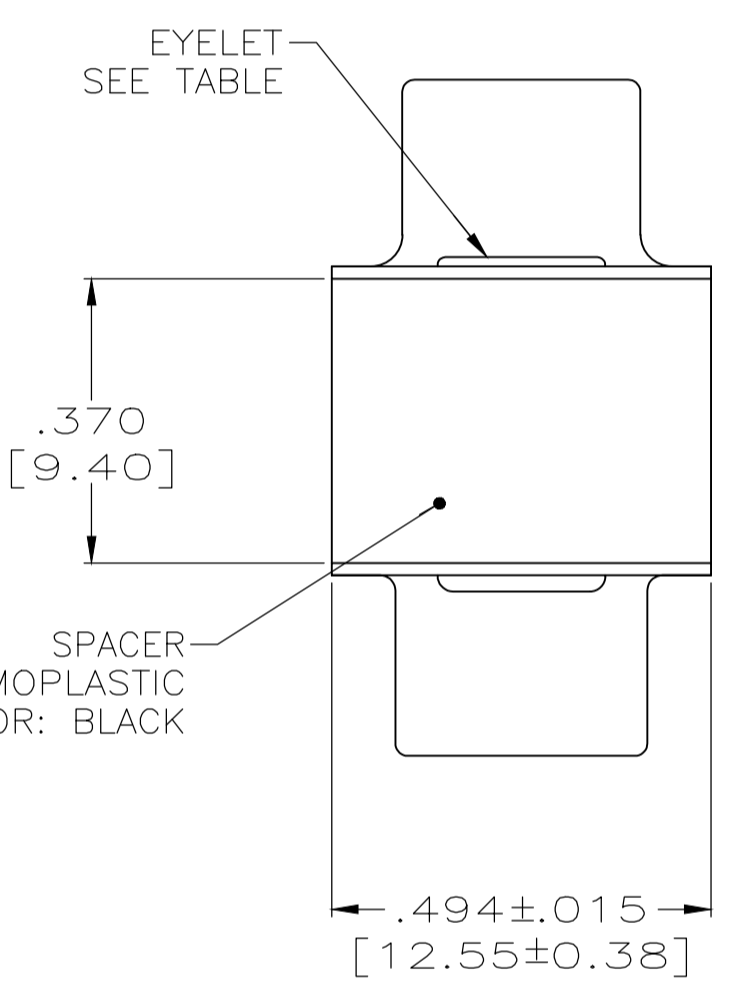
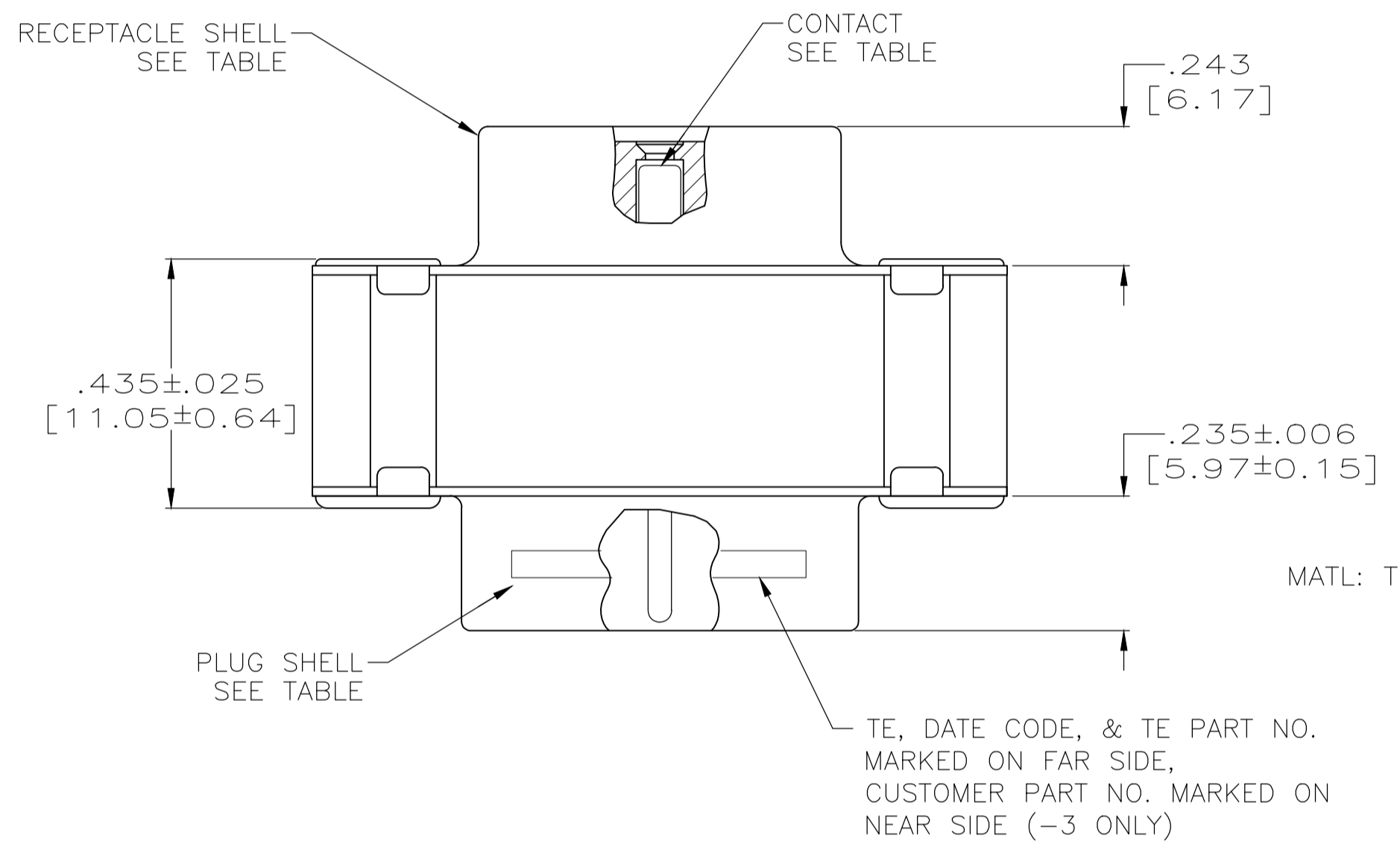
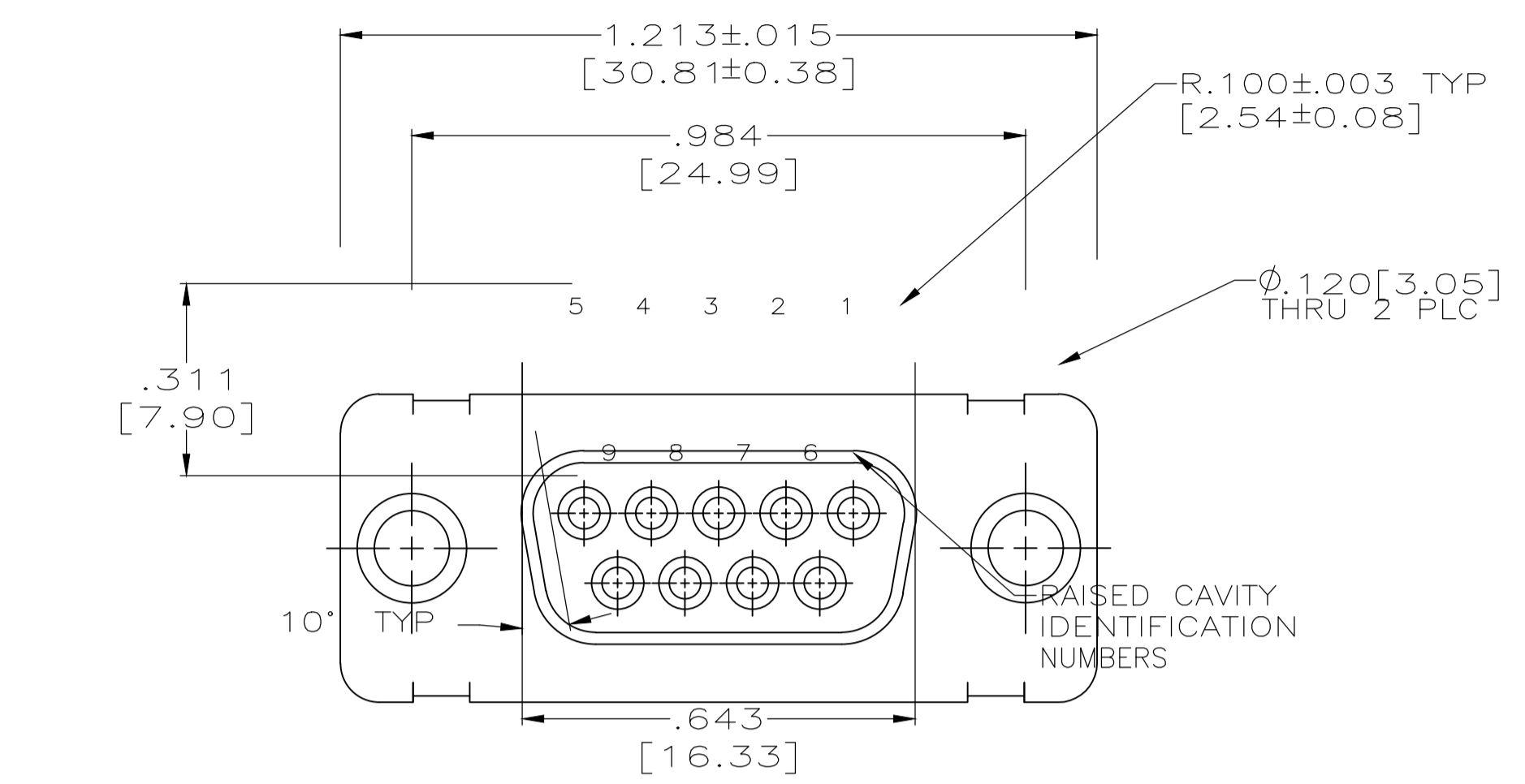

- 1. CONTACTS INCLUDED IN ASSEMBLY.
- △ MATL: STEEL, PER ASTM-A-109.
- △ FINISH: CADMIUM PER QQ-P-416.
- △ CONTACT
- △ BODY MATL: BERYLLIUM COPPER PER ASTM-B-197.
- △ BODY FINISH: PLATED GOLD, .000050 MIN THK PER ASTM-B-488 OVER NICKEL, .000050 MIN THK PER QQ-N-290.
- △ HOOD MATL: STAINLESS STEEL PER ASTM-A-167.
- △ HOOD FINISH: PASSIVATED PER ASTM-A-380
- △ FINISH: PLATED ZINC .00020 MIN THK PER ASTM-B-633. YELLOW CHROMATE FINISH.
- △ MATL: BRASS PER ASTM-B-36.
- △ FINISH: PLATED GOLD, .000050 MIN THK PER ASTM-B-488 OVER COPPER, .000100 MIN THK PER MIL-C-14550.
- △ CONTACT
- △ BODY MATL: BERYLLIUM COPPER PER ASTM-B-197.
- △ BODY AND HOOD FINISH: PLATED GOLD, .000050 MIN THK PER ASTM-B-488 OVER COPPER, .000100 MIN THK PER MIL-C-14550.
- △ HOOD MATL: BRASS PER ASTM-B-36
- △ FINISH: PLATED ZINC PER ASTM-B-633 .000200 MIN THK WITH SUPPLEMENTARY CHROMATE (Cr3+).
- △ CUSTOMER PART NUMBER MARKING FOR -5

△ 6 △ 9	△ 2 △ 9	△ 4	-	5-212559-1
△ 6 △ 7	△ 7 △ 6	△ 4	4U884 SOCN R10002677-0101 △ 10	212559-5
OBSOLETE	-	-	-	212559-4
△ 6 △ 7	△ 7 △ 6	△ 4	(1J02-101)	212559-3
△ 6 △ 7	△ 7 △ 6	△ 8	-	212559-2
△ 6 △ 5	△ 2 △ 3	△ 4	-	212559-1
EYELET	SHELLS	CONTACT	CUSTOMER P/N	PART NO.

THIS DRAWING IS A CONTROLLED DOCUMENT.		DIN T. THOMPSON 11-07-94		TE Connectivity																			
DIMENSIONS: INCHES		TOLERANCES UNLESS OTHERWISE SPECIFIED:		NAME																			
<table border="1"> <tr><td>0 PLC</td><td>± .005</td></tr> <tr><td>1 PLC</td><td>± .005</td></tr> <tr><td>2 PLC</td><td>± .005</td></tr> <tr><td>3 PLC</td><td>± .005 [0.13]</td></tr> <tr><td>4 PLC</td><td>± .005</td></tr> <tr><td>ANGLES</td><td>± .1</td></tr> </table>		0 PLC	± .005	1 PLC	± .005	2 PLC	± .005	3 PLC	± .005 [0.13]	4 PLC	± .005	ANGLES	± .1	<table border="1"> <tr><td>APVD</td><td>D. MANTIONE 11-10-94</td></tr> <tr><td>PRODUCT SPEC</td><td></td></tr> <tr><td>APPLICATION SPEC</td><td></td></tr> </table>		APVD	D. MANTIONE 11-10-94	PRODUCT SPEC		APPLICATION SPEC		CONNECTOR SAVER, AMPLIMITE 9 POSITION, SIZE 1, SERIES 109	
0 PLC	± .005																						
1 PLC	± .005																						
2 PLC	± .005																						
3 PLC	± .005 [0.13]																						
4 PLC	± .005																						
ANGLES	± .1																						
APVD	D. MANTIONE 11-10-94																						
PRODUCT SPEC																							
APPLICATION SPEC																							
MATERIAL		FINISH		RESTRICTED TO																			
-		-		-																			
WEIGHT		0.000000		SCALE 4:1 SHEET 1 OF 1 REV U																			
CUSTOMER DRAWING		A1 00779 C=212559		SCALE 4:1 SHEET 1 OF 1 REV U																			