

REVISIONS					
P	LTR	DESCRIPTION	DATE	DMN	APVD
B2		REVISED PER ECR-19-007953	23MAY2019	SR	PO

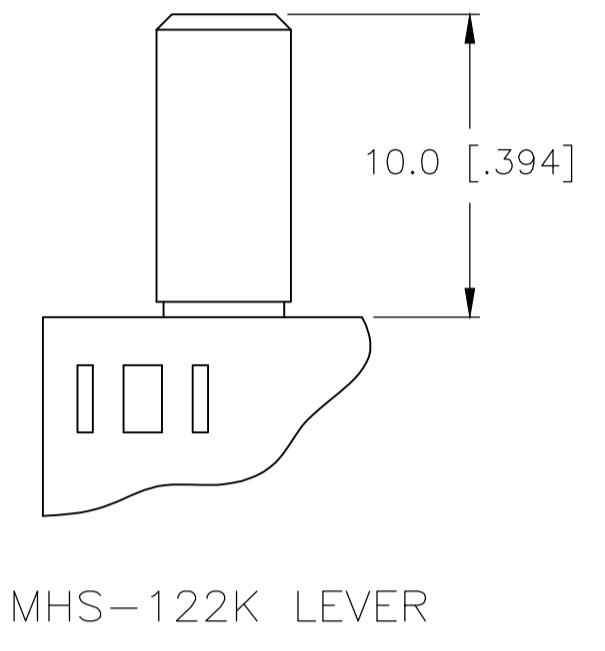
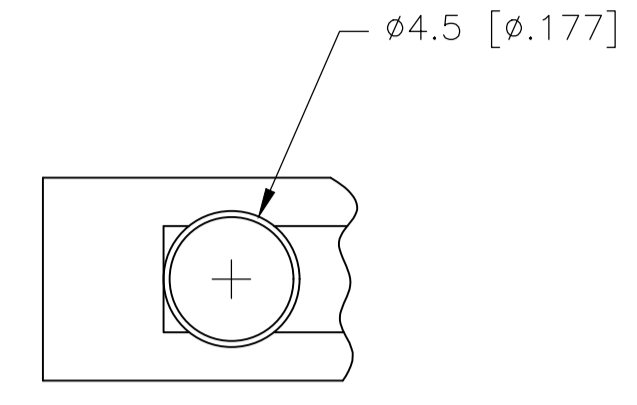
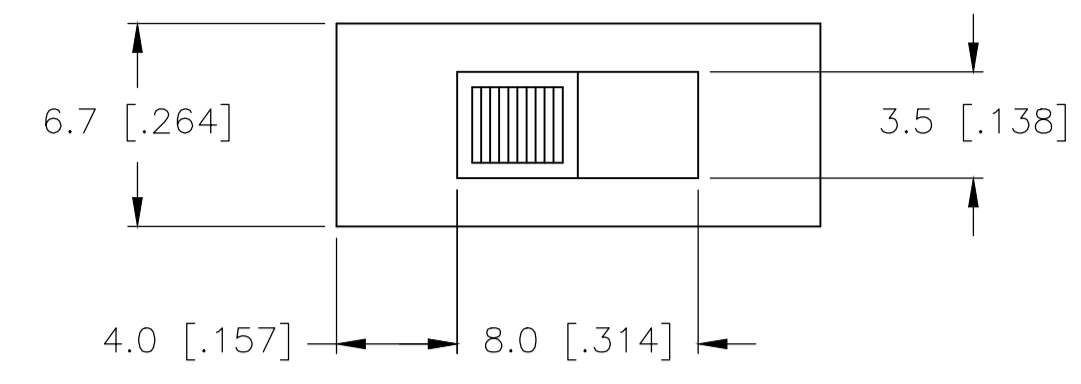

SPECIFICATIONS
BREAK-BEFORE-MAKE

MATERIALS:
 ACTUATOR- NYLON, UL94HB BLACK
 TERMINAL BOARD- PHENOLIC LAMINATED SHEET, UL94HB, NATURAL
 FRAME- STEEL, NICKEL PLATE
 TERMINAL/FIXED CONTACT- COPPER ALLOY, GOLD OR SILVER OVER NICKEL PLATE
 MOVING CONTACT- COPPER ALLOY, GOLD OR SILVER OVER NICKEL PLATE
 DETENT BALL- STEEL
 COIL SPRING- GALVANIZED SPRING WIRE
 LEVER,(K SERIES ONLY)- ALUMINUM
 SEAL- EPOXY

ELECTRICAL:
 CONTACT RATING- .4VA@20VDC OR PEAK AC (GOLD); 300mA@125V AC (SILVER)
 INITIAL CONTACT RESISTANCE- 30 milliohm max.
 FINAL CONTACT RESISTANCE- 100 milliohm max. (AFTER TEST)
 INSULATION RESISTANCE- 1,000 Megohms min.
 DIELECTRIC STRENGTH- 500V RMS@SEA LEVEL
 LIFE EXPECTANCY- 15,000 CYCLES MIN.

MECHANICAL:
 ACTUATION FORCE - SEE P/N TABLE
 TRAVEL- SEE P/N TABLE

ENVIRONMENTAL:
 OPERATING TEMPERATURE- -20 TO +85 DEGREES C
 STORAGE TEMPERATURE- -40 TO +100 DEGREES C
 RESISTANCE TO SOLDER HEAT PER 109-202, CONDITION B
 SOLDERABILITY PER EIA-364-52, CLASS 2, CATEGORY 1, 95% MIN COVERAGE

- 1 COUNTRY OF ORIGIN AND TE CONNECTIVITY LOGO LOCATED APPROXIMATELY AS SHOWN.
- 2 ALL MATERIALS AND FINISHES SHALL COMPLY WITH EU DIRECTIVE 2002/95/EC OF 27JAN2003 (ROHS).
- 3 ANTI SOLDER WICK SEAL AT TERMINAL TO BOARD INTERFACE.
- 4 ALL PERFORMANCE TESTING WAS DONE IN ACCORDANCE TO TE CONNECTIVITY SPECIFICATION 102-2469.
- 5 OBSOLETE PARTS: OBSOLETE CIS STREAMLINING PER D.RENAUD/D.SINISI.
- 6 FOR TE PART NO. 1-1825255-1, LEVER LENGTH IS 15.0 [.591].
- 7 600±300 GRAMS.
- 8 300±200 GRAMS.
- 9 200±100 GRAMS.

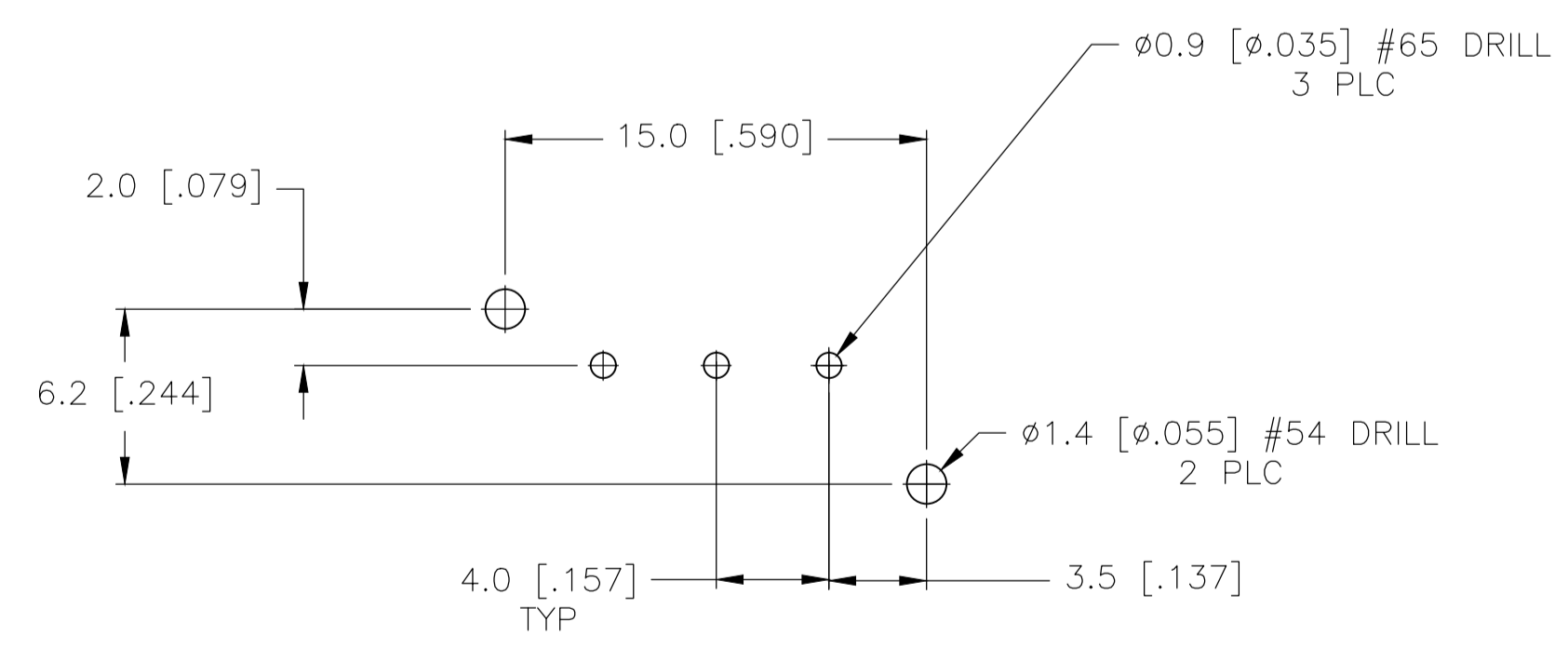
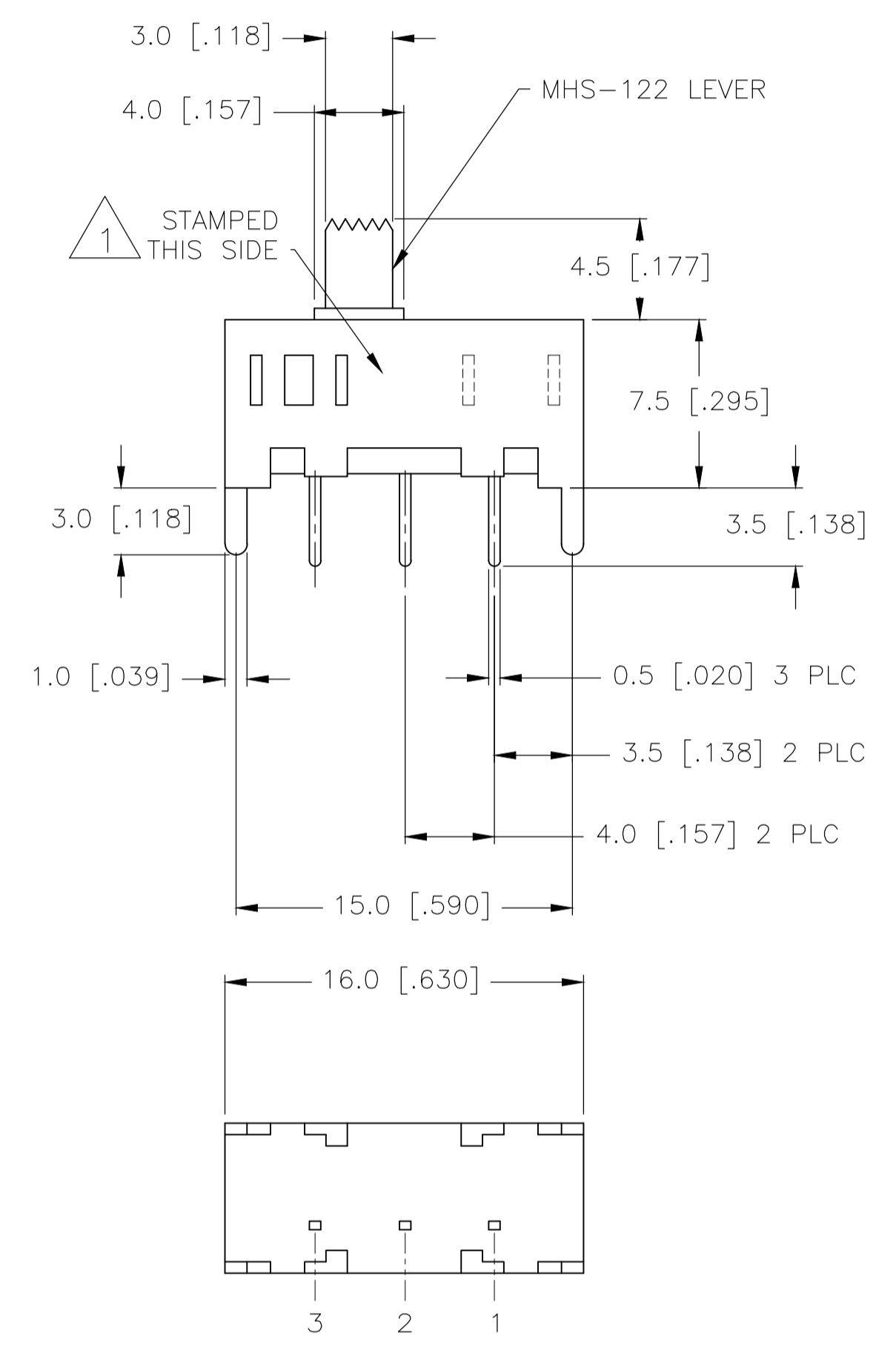
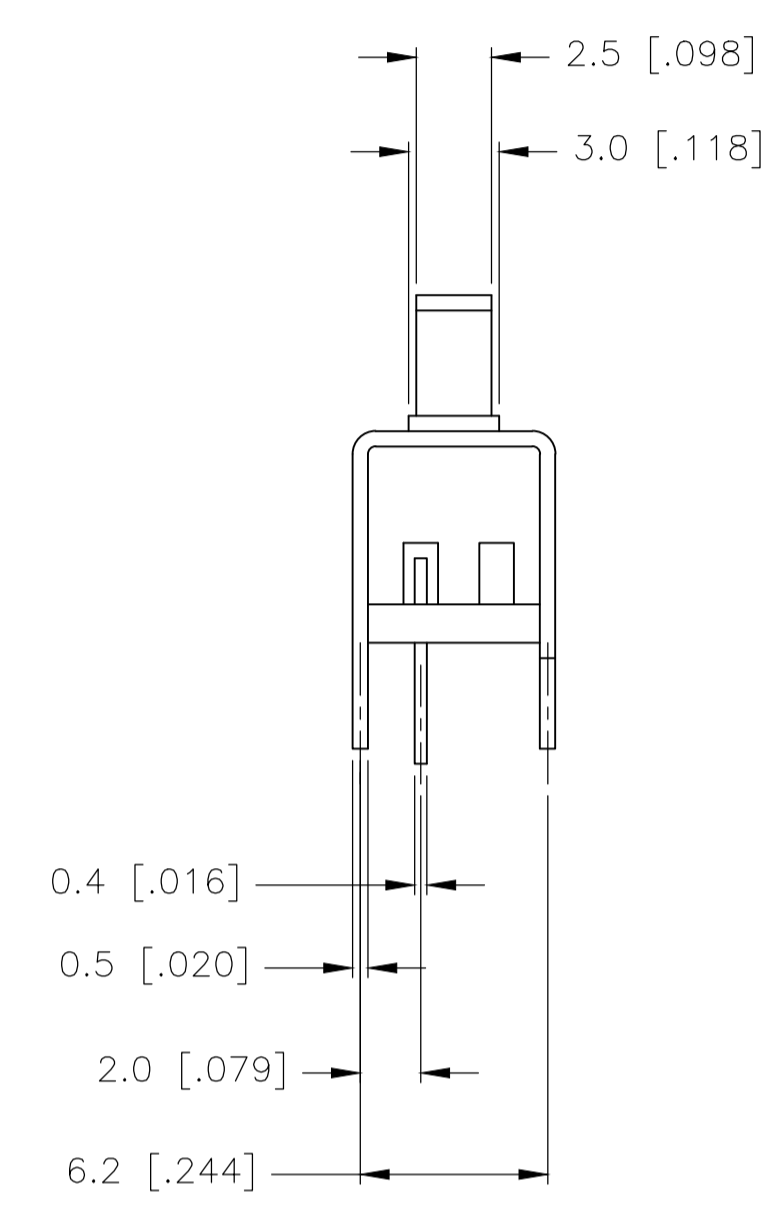

RECOMMENDED BOARD LAYOUT
 PC LAYOUT TOLERANCE: ±.002

MHS-122 SERIES SWITCH

PART NO.	T&B PART NO.	PACKAGING	TYPE	TRAVEL	PLATING	TE 1 2 3	TE 1 2 3	TE 1 2 3	TE 1 2 3	TE 1 2 3	TE 1 2 3	ACTUATION FORCE
1-1825255-4	MHS12204TR	TAPE & REEL	SPDT	4.00	SILVER	2-1	-	NONE	-	2-3	-	7
1-1825255-3	MHS12204TR	TAPE & REEL	SPDT	4.00	SILVER	2-1	-	NONE	-	2-3	-	7
1-1825255-2	MHS122XXTR	TAPE & REEL	SPDT	4.00	SILVER	2-1	-	NONE	-	2-3	-	8
1-1825255-1	-	TRAY	SPDT	2.00	SILVER	2-1	-	OFF	-	2-3	-	7
1-1825255-0	MHS133KG04		SP3T	2.00	GOLD	-	2-1	-	2-3	-	2-4	
1825255-9	MHS133K04		SP3T	2.00	SILVER	-	2-1	-	2-3	-	2-4	
1825255-8	MHS133G04		SP3T	2.00	GOLD	-	2-1	-	2-3	-	2-4	
1825255-7	MHS13304		SP3T	2.00	SILVER	-	2-1	-	2-3	-	2-4	
-	MHS123KG04		SPDT	2.00	GOLD	2-1	-	OFF	-	2-3	-	
OBSOLETE 1825255-6	MHS123K04		SPDT	2.00	SILVER	2-1	-	OFF	-	2-3	-	
-	MHS123G04		SPDT	2.00	GOLD	2-1	-	OFF	-	2-3	-	
1825255-5	MHS12304		SPDT	2.00	SILVER	2-1	-	OFF	-	2-3	-	
1825255-4	MHS122KG04		SPDT	4.00	GOLD	2-1	-	NONE	-	2-3	-	
1825255-3	MHS122K04	SPDT	4.00	SILVER	2-1	-	NONE	-	2-3	-		
OBSOLETE 1825255-2	MHS122G04	SPDT	4.00	GOLD	2-1	-	NONE	-	2-3	-		
1825255-1	MHS12204	SPDT	4.00	SILVER	2-1	-	NONE	-	2-3	-		

THIS DRAWING IS A CONTROLLED DOCUMENT.

TE Connectivity

SLIDE SWITCH, MHS SERIES, SINGLE POLE, VERTICAL

APPROVED: M SARVER

DATE: 21DEC05

SCALE: 4:1 SHEET 1 OF 2 REV B2

REVISIONS				
P	LYR	DESCRIPTION	DATE	APPD
-	-	SEE SHEET 1	-	-

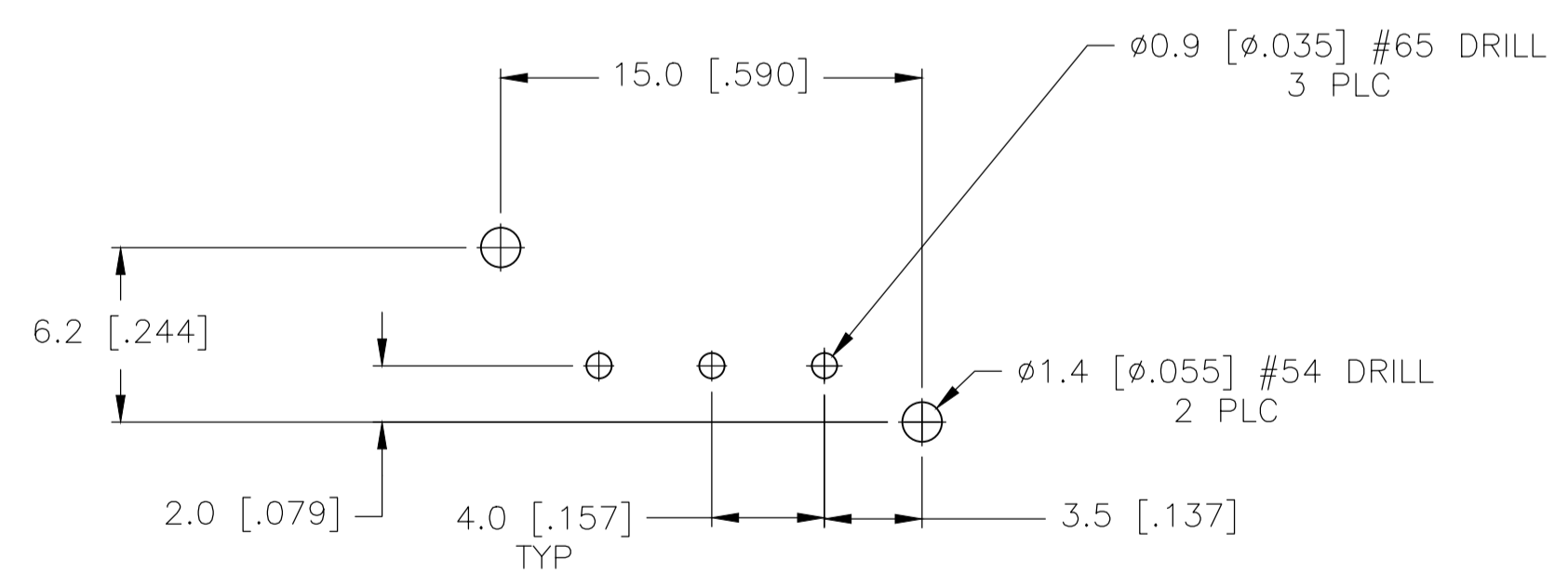
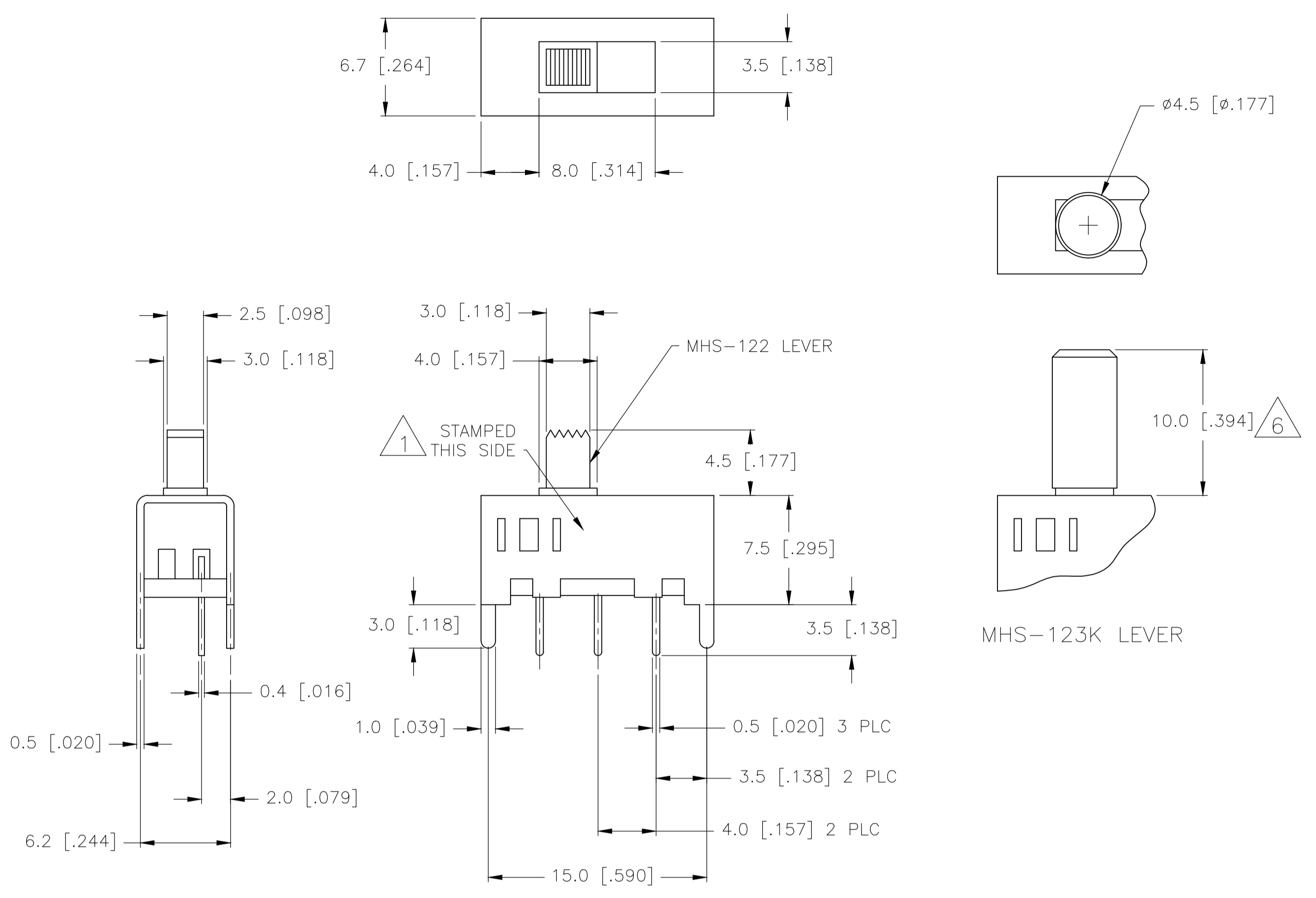

RECOMMENDED BOARD LAYOUT
PC LAYOUT TOLERANCE: ± 0.002

MHS-123 SERIES SWITCH

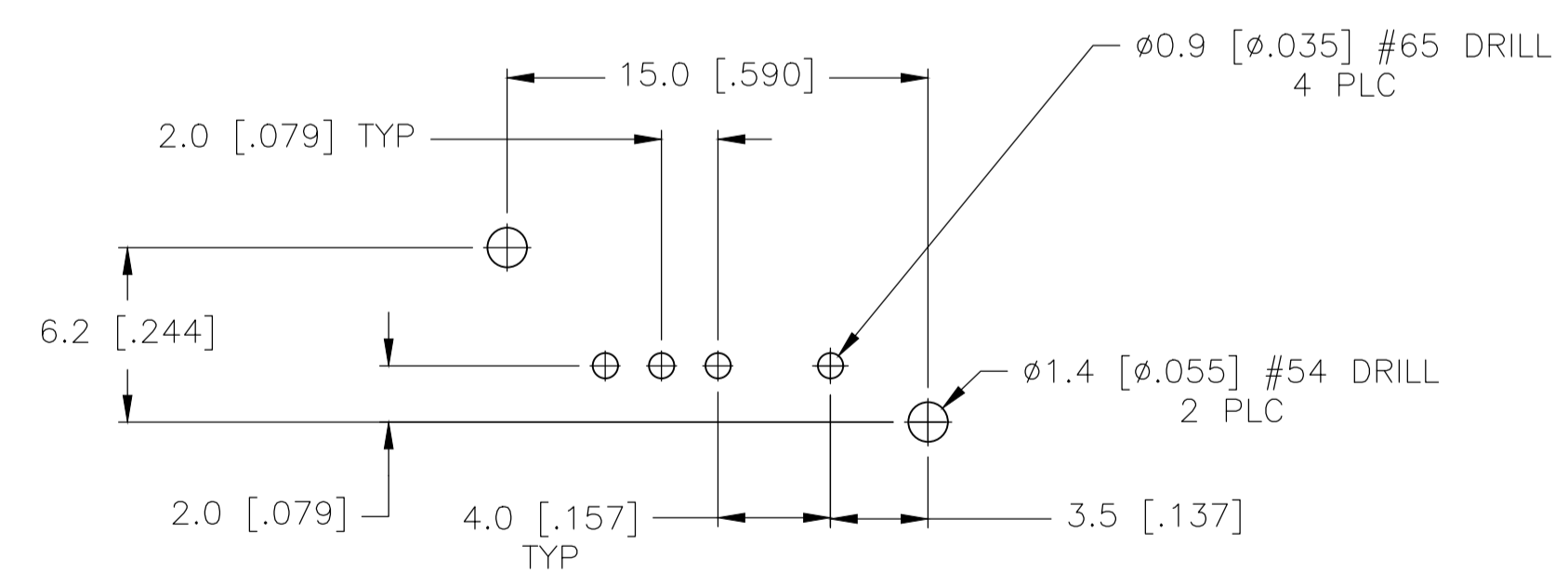
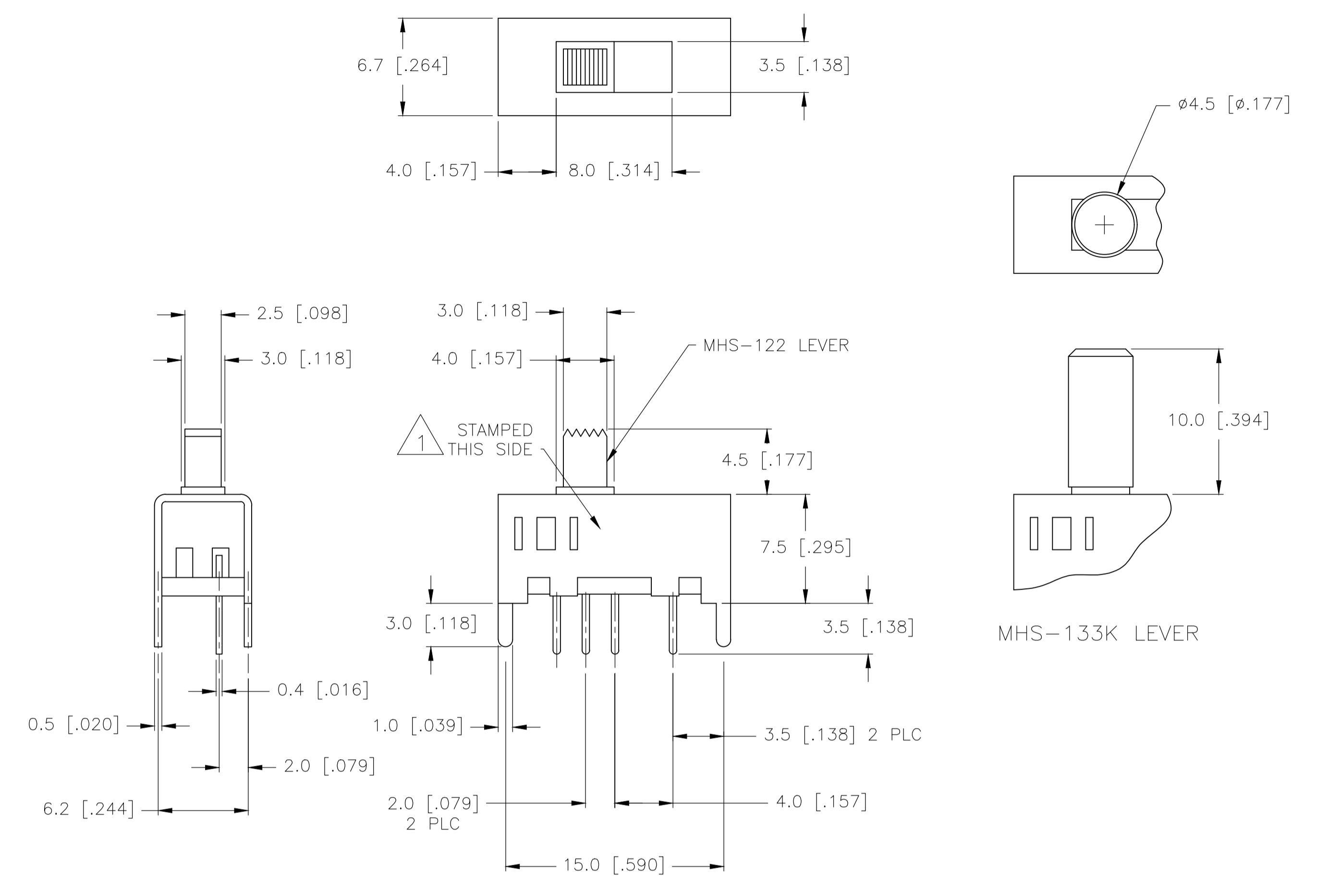

RECOMMENDED BOARD LAYOUT
PC LAYOUT TOLERANCE: ± 0.002

MHS-133 SERIES SWITCH

THIS DRAWING IS A CONTROLLED DOCUMENT.		DIN R BROWN 21DEC05	TE Connectivity
DIMENSIONS: mm [INCHES]		CHK M SARVER 21DEC05	
TOLERANCES UNLESS OTHERWISE SPECIFIED:		APPD M SARVER 21DEC05	NAME
0 PLC \pm -	1 PLC ± 0.3 [.012]	PRODUCT SPEC	SLIDE SWITCH, MHS SERIES, SINGLE POLE, VERTICAL
2 PLC \pm -	3 PLC \pm -	APPLICATION SPEC	-
4 PLC \pm -	ANGLES $\pm 1^\circ$	WEIGHT	SIZE CAGE CODE DRAWING NO. RESTRICTED TO
MATERIAL -	FINISH -	A1 00779 1825255	SCALE 4:1 SHEET 2 OF 2 REV B2
CUSTOMER DRAWING		SCALE 4:1 SHEET 2 OF 2 REV B2	