

THIS DRAWING IS UNPUBLISHED. RELEASED FOR PUBLICATION
 © COPYRIGHT - By - ALL RIGHTS RESERVED.

LOC	DIST	REVISIONS			
P	LTR	DESCRIPTION	DATE	DWN	APVD
AD	00	M1	REVISED PER ECO-11-004917	11MAR11	RK HMR

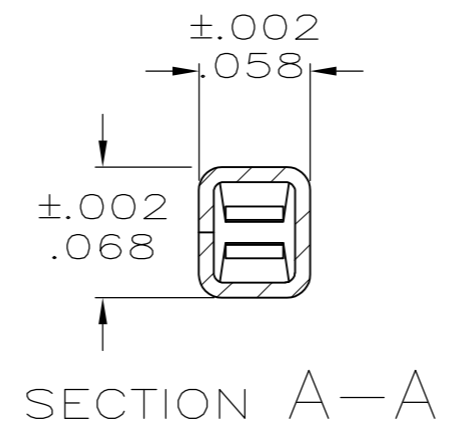

SECTION A-A

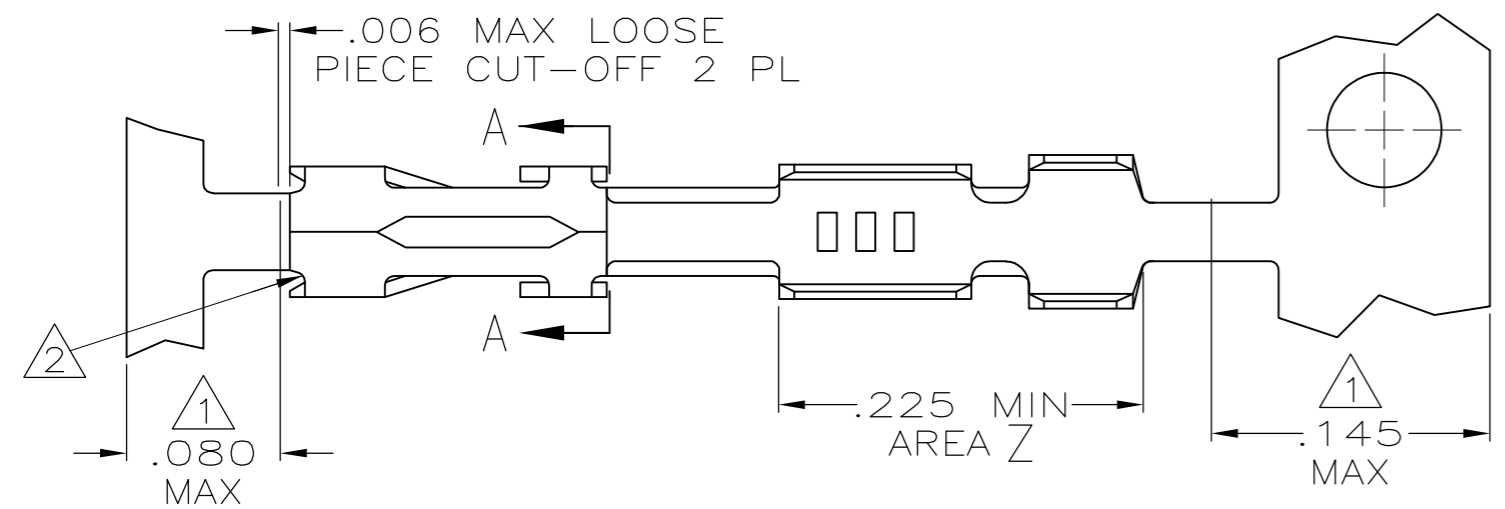
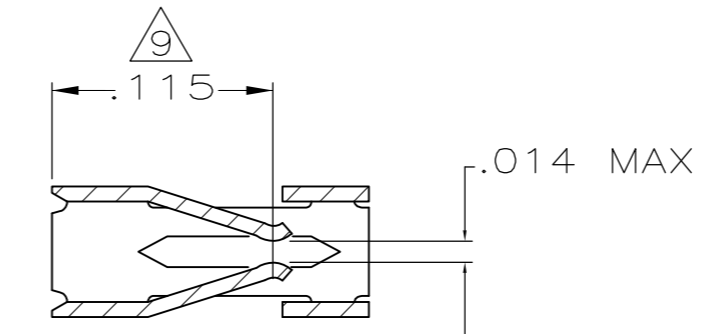

SECTION B-B

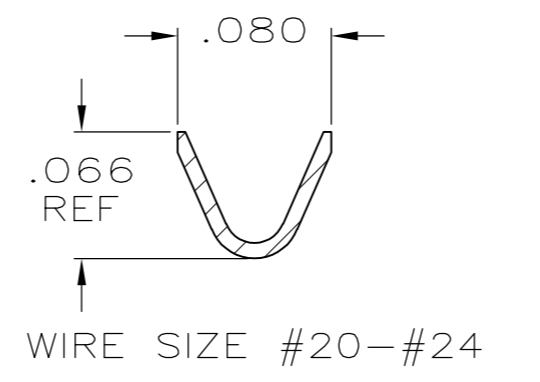

SECTION C-C

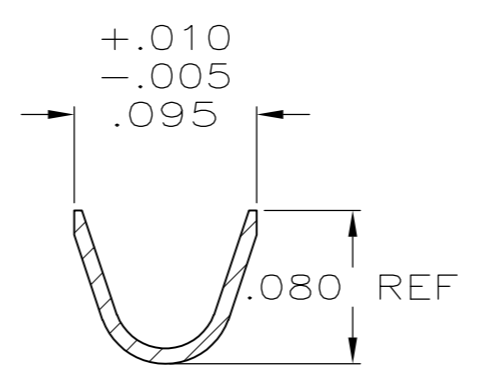
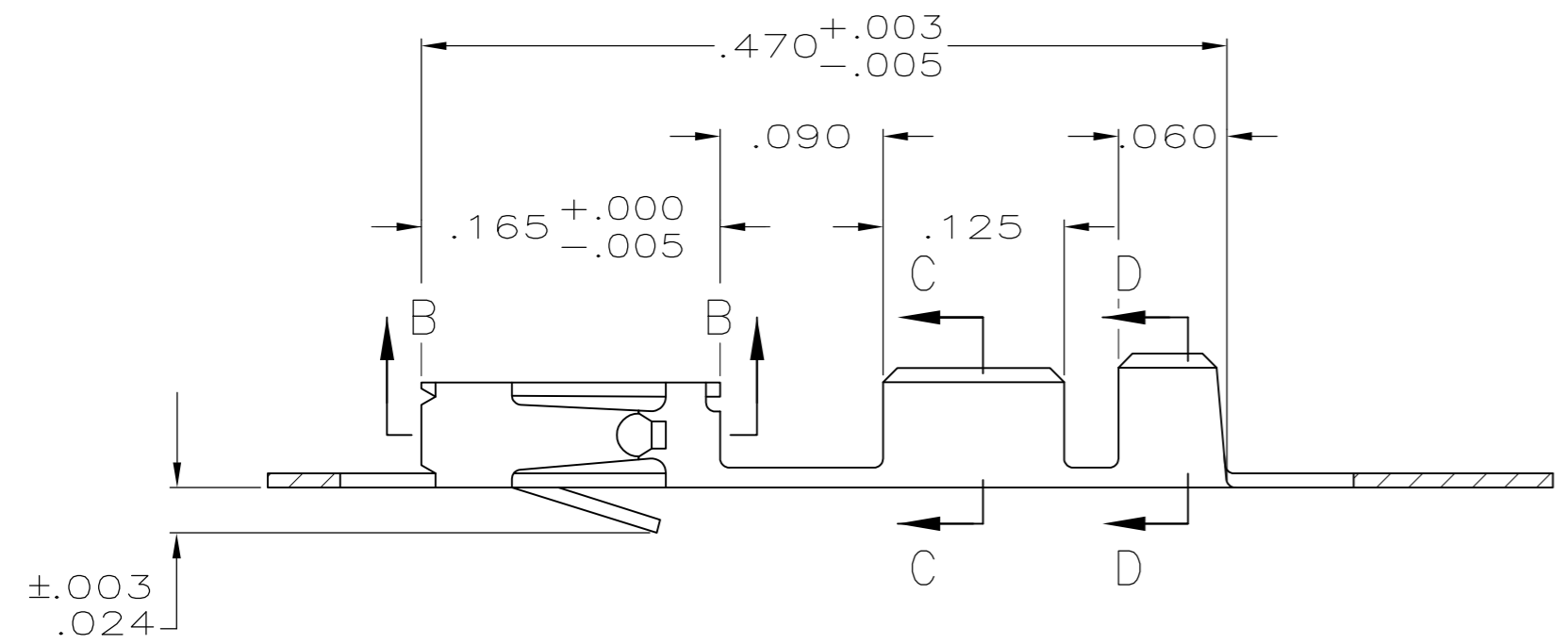

SECTION D-D

- 1 GOLD PLATING IS NOT REQUIRED IN THIS AREA.
- 2 CUT-OUTS ON THE BOX ARE AT MANUFACTURERS OPTION.
- 3 THIS TERMINAL IS REELED FOR THE STANDARD APPLICATOR.
- 4 THIS TERMINAL IS REELED FOR THE MINI APPLICATOR.
- 5 .000015 GOLD ON THE CONTACT AREA, GOLD FLASH ON THE REMAINDER ALL OVER .000050 NICKEL.
- 6 .000030 GOLD OVER .000050 NICKEL.
- 7 .000030 GOLD ON THE CONTACT AREA, GOLD FLASH ON THE REMAINDER ALL OVER .000050 NICKEL.
- 8 .000100-.000200 BRIGHT TIN-LEAD OVER .000050 NICKEL.
- 9 POINT OF MEASUREMENT FOR PLATING THICKNESS (INSIDE BEAMS).
- 10 SHEARED EDGES ARE PERMITTED TO BE UNPLATED.
- 11 .000015 GOLD ON THE CONTACT AREA, .000100-.000200 BRIGHT TIN-LEAD ON AREA Z, ALL OVER .000050 NICKEL.
- 12 .000030 GOLD ON THE CONTACT AREA, .000100-.000200 BRIGHT TIN-LEAD ON AREA Z, ALL OVER .000050 NICKEL.
- 13 .000030 GOLD ON CONTACT AREA, .000100-.000200 TIN ON AREA Z, ALL OVER .000050 NICKEL.
- 14 .000015 GOLD ON CONTACT AREA, .000100-.000200 TIN ON AREA Z, ALL OVER .000050 NICKEL.

REMARKS	FINISH	LOOSE PIECE PART NUMBER	PART NUMBER		
4	10	14	2-87195-5	2-87195-4	
4	10	13	2-87195-6	2-87195-3	
4	10	12	2-87195-1	2-87195-0	
	4	10	11	1-87195-8	1-87195-7
OBSOLETE	4	8		1-87195-6	1-87195-5
OBSOLETE		3	8	1-87195-6	1-87195-4
OBSOLETE	4	7		1-87195-0	87195-9
OBSOLETE		3	7	1-87195-0	87195-8
OBSOLETE	4	6		87195-7	87195-6
OBSOLETE		3	6	87195-7	87195-5
OBSOLETE	4	5		87195-4	87195-3
OBSOLETE		3	5	87195-4	87195-2

THIS DRAWING IS A CONTROLLED DOCUMENT.

DWN	L.D.RINGLEY	1-6-86
CHK	J.L.GESFORD	1-6-86
APVD	J.GESFORD	1-6-86

TE Connectivity

CONTACT, MOD IV 1/2, RECEPTACLE, CRIMP

SIZE	A2	CAGE CODE	00779	DRAWING NO	C=87195	RESTRICTED TO	-
SCALE	10:1	SHEET	1 of 1	REV	M1		