

OV2680/OV2685 2MP product brief



Cost-Effective, Low-Power 2-Megapixel Sensors for Feature Phones, Smartphones and Tablets



available in
a lead-free
package

The OV2680 (RAW) and OV2685 (SoC) are cost-effective, low-power 2-megapixel CameraChip™ sensors for feature phones and front-facing camera applications in smartphones and tablets. The 1/5-inch sensors leverage a 1.75-micron OmniPixel3-HS™ pixel to deliver high quality 2-megapixel images and video at 30 frames per second (fps). The sensors' high sensitivity and low dark current deliver exceptional image and video quality, even in low-light conditions.

The OV2680 and OV2685 are cost-effective upgrade solutions to the OV2659 & OV2675 CameraChip sensors with a smaller footprint and smaller die size.

Compared to previous generations, the OV2680 and OV2685 offer improved image quality with the latest OmniPixel3-HS pixel architecture. Using OmniVision's proprietary sensor technology, both sensors reduce or eliminate common lighting and electrical sources of image contamination, such as fixed pattern noise, smearing, etc., to produce a clean, stable, color image.

The OV2680 and OV2685 both feature a single-lane MIPI interface, which allows for a simple design with modern basebands.

Find out more at www.ovt.com.

Applications

- Ultrabooks
- PC Multimedia
- Games
- Home Entertainment
- Cellular and Picture Phones
- Tablets
- Toys

Product Features

- MIPI and D-PHY specification (contains one clock lane) with a maximum of 750 Mbps data transfer rate
- support for output formats:
 - OV2680: 10-bit RAW RGB
 - OV2685: 10-bit RAW RGB, 8-bit YUV
- programmable controls for frame rate, mirror and flip, cropping, and windowing
- low operating voltage and low power consumption for embedded portable applications
- supports global analog gain
- high sensitivity and low dark current for low-light conditions
- supports free-running clock and gated clock
- supports down-sampling and binning mode
- auto black level calibration
- defect correction capability
- supports horizontal and vertical subsampling

OV2680/OV2685



Ordering Information

- OV02680-H47A (color, lead-free, 47-pin CSP5)
- OV02685-H53A (color, lead-free, 53-pin CSP5)

Product Specifications

- active array size: 1616 x 1216
- lens size: 1/5"
- lens chief ray angle: 28.5° non-linear
- input clock frequency: 6 - 27 MHz
- maximum image transfer rate: 30 fps
- scan mode: progressive
- maximum exposure interval: 1 frame - 4 t_{row}
- pixel size: 1.75 μm x 1.75 μm
- image area: 2840 μm x 2150 μm
- package/die dimensions:
 - OV2680 CSP5: 4180 μm x 3480 μm
 - OV2685 CSP5: 4454 μm x 4014 μm
- power supply:
 - OV2680 core: 1.58V ±3%
 - OV2685 core: 1.7 - 1.9V
 - analog: 2.6 - 3.0V
 - I/O: 1.7 - 3.0V
- power requirements:
 - OV2680 active: 123 mW
 - OV2685 active: 259 mW
 - XSHUTDOWN: <1 μA
- temperature range:
 - operating: -30°C to +85°C junction temperature
 - stable image: 0°C to +50°C junction temperature
- output formats: 10-bit RGB RAW, 8-bit YUV (OV2685)

Functional Block Diagram

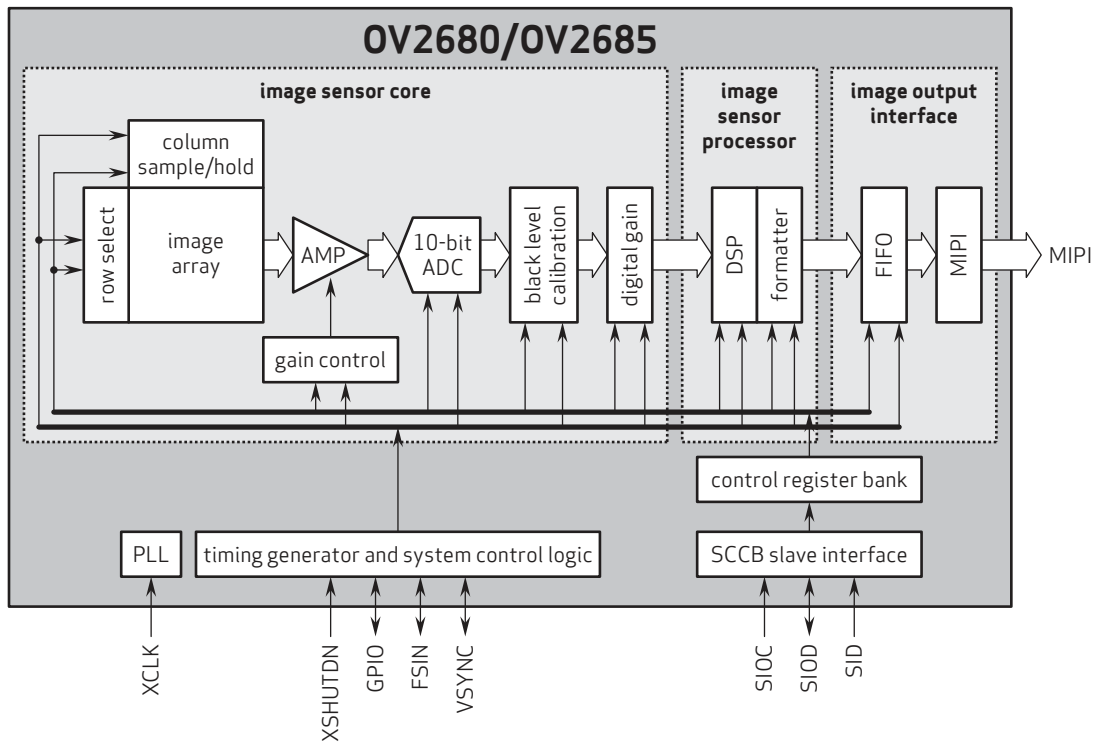

4275 Burton Drive
Santa Clara, CA 95054
USA

Tel: + 1 408 567 3000
Fax: + 1 408 567 3001
www.ovt.com

OmniVision reserves the right to make changes to their products or to discontinue any product or service without further notice. OmniVision and VarioPixel are registered trademarks of OmniVision Technologies, Inc. The OmniVision logo and OmniPixel3-H5 are trademarks of OmniVision Technologies, Inc. All other trademarks are the property of their respective owners.

