

Quasi-Resonant Flyback Converter Universal Off-Line Input 65-W Evaluation Module

User's Guide



Literature Number: SLUU263C
October 2006–Revised June 2010

Quasi-Resonant Flyback Converter Universal Off-Line Input 65-W EVM

The UCC28600 evaluation module, (UCC28600EVM-65 W), is a 65-W off-line quasi-resonant flyback converter providing an 18-V regulated output at 3.6 A of load current, operating from a universal ac input between 85 V_{AC} and 265 V_{AC} with a frequency range of 47 Hz to 63 Hz. The EVM uses the UCC28600 quasi-resonant flyback green-mode controller which integrates built-in state of the art energy saving features with high-level protection features to provide cost effective solutions for energy efficient power supplies.

1 Description

The UCC28600EVM-65 W highlights the many benefits of using the UCC28600 quasi-resonant flyback green-mode controller and can also serve as a close-to-final product reference design. Low system parts count and multifunction pins in this green-mode controller provide a cost-effective solution while meeting stringent world-wide energy efficiency requirements. This user's guide provides the schematic, component list, and assembly drawing for a single-sided PCB application, artwork, and test set up necessary to evaluate the UCC28600 controller in a typical off-line converter application. The EVM is designed for either dual output or single output. At present, only single output (OUT1) is available.

The UCC28600EVM-65 W features:

- Regulated 18-V and 65-W dc output
- Universal off-line input voltage 85 V_{AC} to 265 V_{AC}
- Meets EPA Energy Star® efficiency requirements and standby power requirements
- Power turn-on time less than 3 seconds
- Input power less than 1-W at 0.5-W output
- Prebias load turn-on with prebias voltage from 0% to 95% of output rated voltage
- Cycle-by-cycle power limit
- Output over-voltage protection
- Embedded over-temperature protection
- Regulation down to zero output current
- Single-sided board layout

2 Operating Guidelines

The operating guidelines for the EVM are provided with reference to the schematic in [Figure 1](#). The set up is shown in [Figure 2](#) for load operation, and [Figure 3](#) for standby mode operation. Equipment set up is described followed by EVM operation.

CAUTION

Proper precautions must be taken when working with the EVM. High voltage levels and temperature higher than 60 °C are present on the EVM when it is powered on.

The large bulk capacitor across the bridge diodes and the output capacitor bank must be completely discharged before the EVM can be handled. Serious injury can occur if proper safety precautions are not followed.

It is important to maintain the ambient temperature around the EVM to below 45°C during operation.

2.1 Test Setup and Schematic Drawing Diagrams

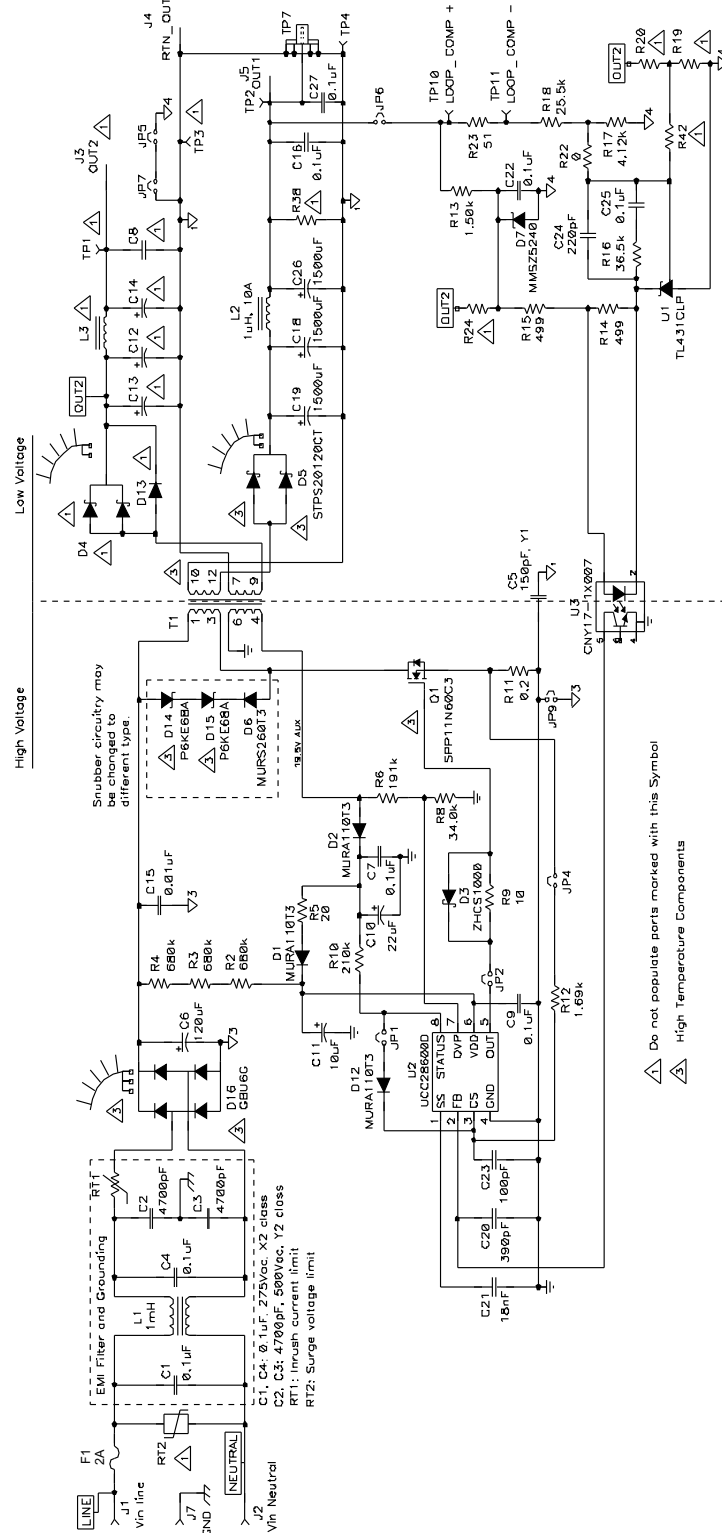
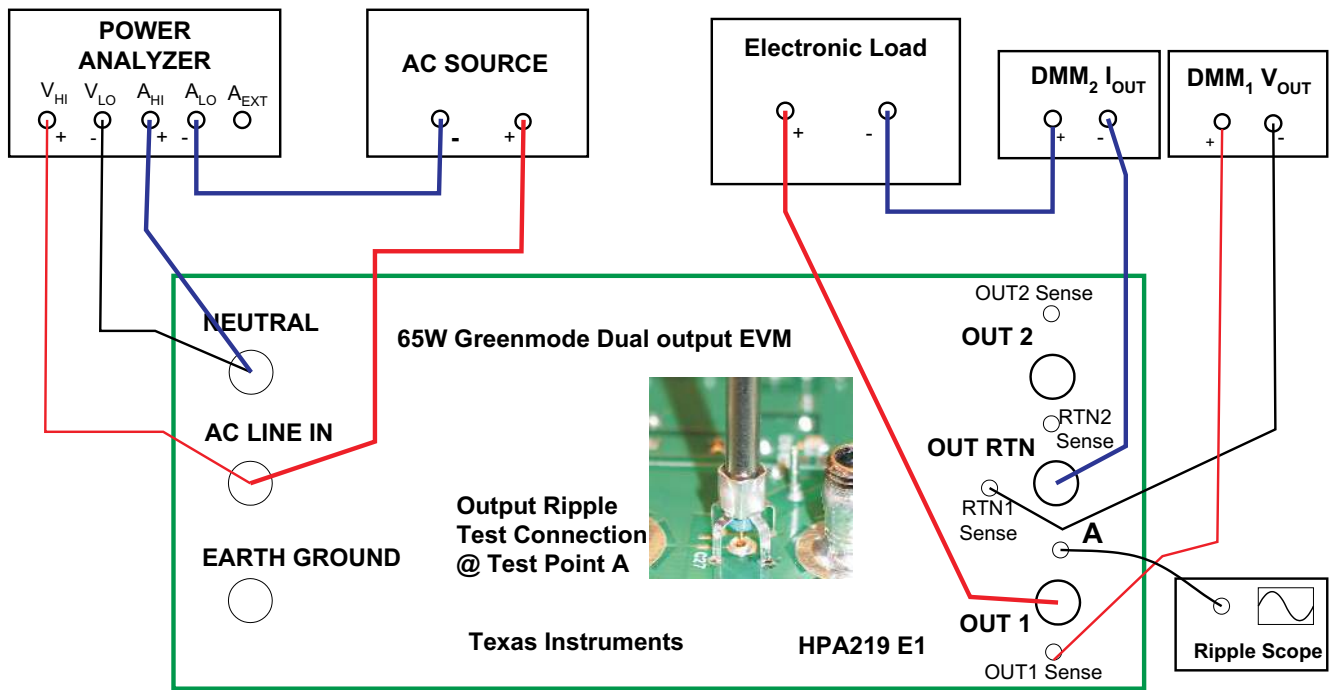

Figure 1. EVM Schematic



A Test point A may be found on the bottom side of the board.

Figure 2. Test Setup for Operation with Load

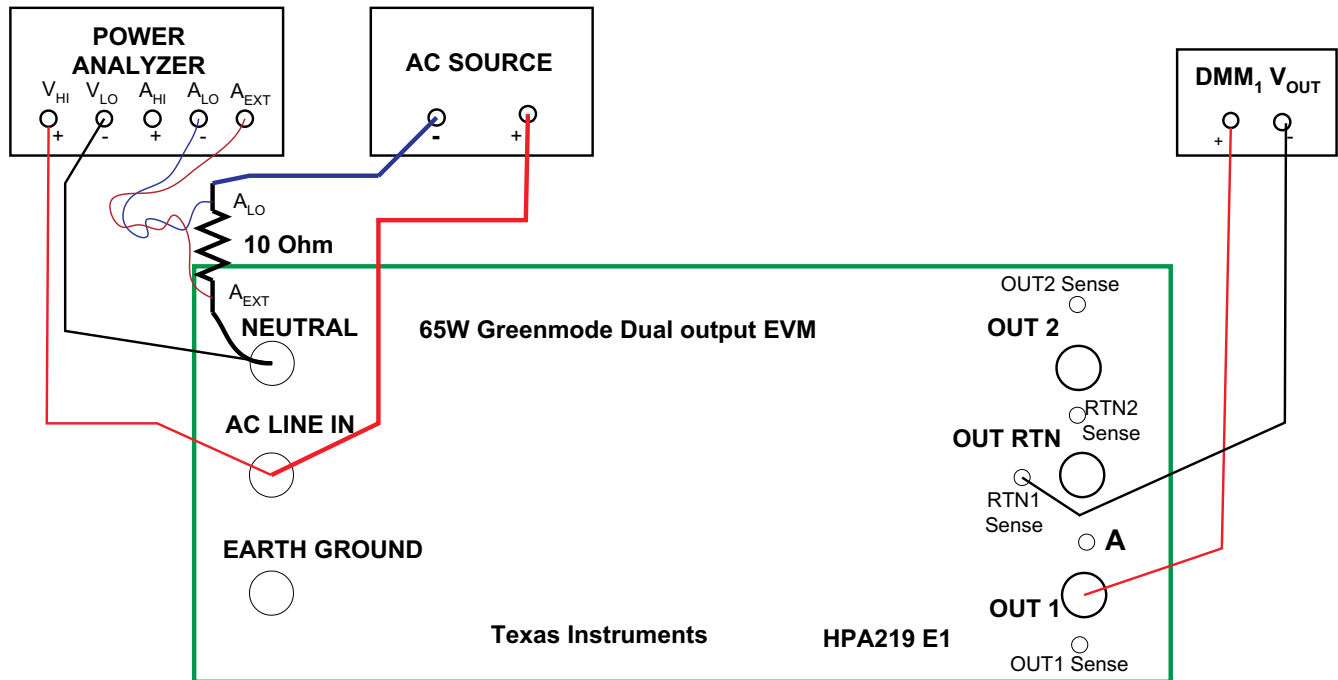

Figure 3. Test Setup for Standby Mode Operation.

2.2 Equipment Set up

2.2.1 Power Meter

The power meter shall be capable of measuring low input current, typically less than 5 mA, and a long averaging mode if low power standby mode input power measurements are to be taken. An example is the Voltech PM100 single phase power analyzer. To measure the intermittent bursts of current and power drawn from the line during no-load operation, requires the use of an external 10- Ω shunt resistor with 1% or better precision, low temperature coefficient and a typical current rating not less than 10 mA as shown in [Figure 3](#).

2.2.2 AC Input Source

The input source shall be a variable ac sinusoidal source capable of supplying between 85 V_{AC} and 265 V_{AC} with frequency range of 47 Hz to 63 Hz and minimum 5-A peak current.

2.2.3 Multimeters

Multimeters are used to measure the output voltage (DMM1) and the output load current (DMM2).

2.2.4 Output Load

A programmable electronic load is recommended configurable for constant current mode and capable of sinking 0 A_{DC} to 4 A_{DC} at 18 V_{DC}. The output voltage can be monitored by connecting a dc voltmeter, DMM1 to sense pins shown in [Figure 2](#) and [Figure 3](#). A dc current meter, DMM2, may be inserted in series with the electronic load for accurate output current measurements.

2.2.5 Oscilloscope

Set the oscilloscope channel to ac coupling with 20-MHz bandwidth.

2.3 Operating EVM

The following steps are guidelines for power up and power down of the EVM.

1. An ESD workstation is recommended. Make sure that an ionizer is on before the EVM is removed from the protective packaging and power is applied to the EVM. Electrostatic smock and safety glasses should also be worn. Because voltages in excess of 400 V may be present on the EVM, do not connect the ground strap from the smock to the bench.
2. Power up.
 - (a) Prior to connecting the ac input source, limit the source current to 2.5 A maximum. Make sure the ac source is initially set between 85 V_{RMS} and 265 V_{RMS} and 47 Hz to 63 Hz prior to turning on. Connect the ac source to the EVM as shown in [Figure 2](#) or [Figure 3](#).
 - (b) Connect the power meter as shown in [Figure 2](#) or [Figure 3](#). If no-load input power measurements are to be made, set the power analyzer to long averaging and external shunt mode. Insert a shunt, such as a 10-Ω resistor as shown in [Figure 3](#), in series with the NEUTRAL terminal of the EVM. Set the appropriate current scale on the power meter.
 - (c) Connect the current meter DMM2 as shown in [Figure 2](#).
 - (d) Connect the volt meter DMM1 as shown in [Figure 2](#) or [Figure 3](#).
 - (e) For operation with a load, connect the electronic load to the EVM as shown in [Figure 2](#). Set the load to constant current mode with initial value of 0 A.
 - (f) Turn on the ac source and observe that the output is regulating to 18 V.
 - (g) Vary the load between 0 A and 3.61 A.
3. Power down.
 - (a) Turn off the ac source.
 - (b) Discharge the output capacitor bank.
 - (c) Turn off the load.
 - (d) Using a volt meter, verify that the output capacitor bank and input bulk capacitor across the bridge diodes is near 0 V before handling the EVM.

3 EVM Typical Performance

Table 1. 65W-EVM Performance Summary

PARAMETER	TEST CONDITION	MIN	TYP	MAX	UNITS
Input Characteristics					
Voltage range	V_{IN}	85		265	V_{AC}
Frequency range	Sinusoidal source	47		63	Hz
Input inrush current, peak	$V_{IN} = 115 V_{AC}$ with 5-Ohm thermistor			35	A
Maximum Input current	$V_{IN} = 115 V_{AC}, I_{OUT} = 3.61 A$			1.37	A_{RMS}
	$V_{IN} = 230 V_{AC}, I_{OUT} = 3.61 A$			0.67	
Output Characteristics					
Output voltage V_O	$85 V_{AC} < V_{IN} < 265 V_{AC}, 0 A < I_{OUT} < 3.61 A$	17.5	18	18.5	V_{DC}
Load current	$85 V_{AC} < V_{IN} < 265 V_{AC}$	0		3.61	A
Continuous output power	$85 V_{AC} < V_{IN} < 265 V_{AC}$			65	W
Line regulation	$85 V_{AC} < V_{IN} < 265 V_{AC}, 0 A < I_{OUT} < 3.61 A$		5		mV
Load regulation	$85 V_{AC} < V_{IN} < 265 V_{AC}, 0 A < I_{OUT} < 3.61 A$		5		
Ripple (20 MHz BW)	$85 V_{AC} < V_{IN} < 265 V_{AC}, 0 A < I_{OUT} < 3.61 A$		10		mV_{RMS}
Noise (20 MHz BW)	$85 V_{AC} < V_{IN} < 265 V_{AC}, 0 A < I_{OUT} < 3.61 A$		75		mV_{pk-pk}
Start-up overshoot	$85 V_{AC} < V_{IN} < 265 V_{AC}, 0 A < I_{OUT} < 3.61 A$		8%		%
Load transient deviation	$85 V_{AC} < V_{IN} < 265 V_{AC}, 0.361 A < I_{OUT} < 3.61 A$		180		mV
OVP limit	$85 V_{AC} < V_{IN} < 265 V_{AC}, 0 A < I_{OUT} < 3.61 A$		23		V_{DC}
Short circuit current	$85 V_{AC} < V_{IN} < 265 V_{AC}$		15		A
Max Power limit	$85 V_{AC} < V_{IN} < 265 V_{AC}$		90		W
V_O pre-bias start range	$85 V_{AC} < V_{IN} < 265 V_{AC}, 0 A < I_{OUT} < 3.61 A$	1%		95%	
Control Characteristics					
Bandwidth / phase margin	$V_{IN} = 115 V_{AC}, I_{OUT} = 3.61 A$		1.6 / 60		kHz/ $^\circ$
	$V_{IN} = 230 V_{AC}, I_{OUT} = 3.61 A$		2.4 / 70		
Turn-on time	$V_{IN} = 85 - 265 V_{AC}, I_{OUT}: 0 - 3.61 A$			2.9	s
Efficiency					
Peak	$V_{IN} = 230 V_{AC}, I_{OUT} = 3.28 A$		88.4%		
Full load	$V_{IN} = 90 V_{AC}, I_{OUT} = 3.61 A$		86.0%		
	$V_{IN} = 115 V_{AC}, I_{OUT} = 3.61 A$		87.0%		
	$V_{IN} = 230 V_{AC}, I_{OUT} = 3.61 A$		88.0%		
	$V_{IN} = 115 V_{AC}$		87.0%		
Energy star (EPA four points average)	$V_{IN} = 115 V_{AC}$		87.0%		
	$V_{IN} = 230 V_{AC}$		88.0%		
Standby power	$V_{IN} = 115 V_{AC}, I_{OUT} = 0 A$			300	mW
	$V_{IN} = 230 V_{AC}, I_{OUT} = 0 A$			300	
	$V_{IN} = 265 V_{AC}, I_{OUT} = 0 A$			300	
Input power	$V_{IN} = 85 - 265 V_{AC}, \text{load} = 0.5 W$			0.85	W
Operation temperature	Full load, natural convection cooling			45	$^\circ C$

4 EVM Typical Performance Curves

Soft Start Waveform
Start-Up Output Voltage Waveform

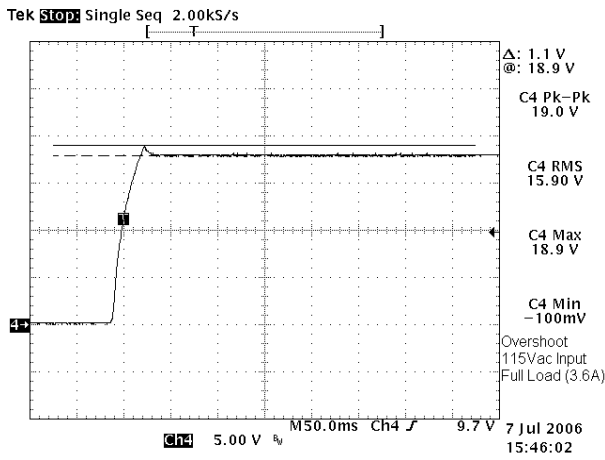

Figure 4.

Soft Start into Prebias Load
Output Voltage Start into Prebias Load

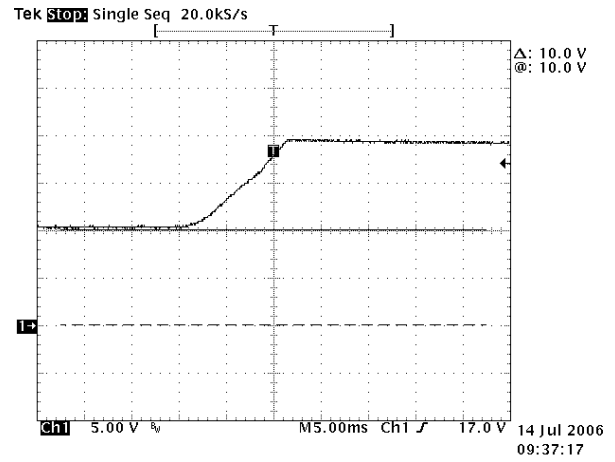

Figure 5.

Typical Turn-On Time
Typical Turn-On Time

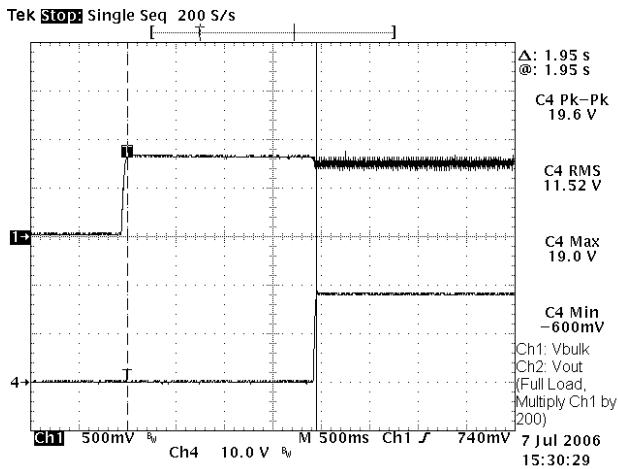

Figure 6.

Output Voltage Ripple
Output Voltage Ripple and Noise

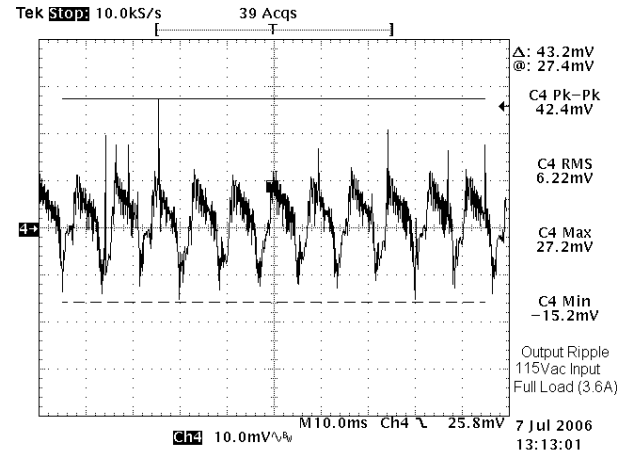

Figure 7.

Waveforms of Drain and Current Sensing Resistor Voltage at FFM
 Drain/Current Sensing Resistor Voltage at Frequency-Foldback Mode

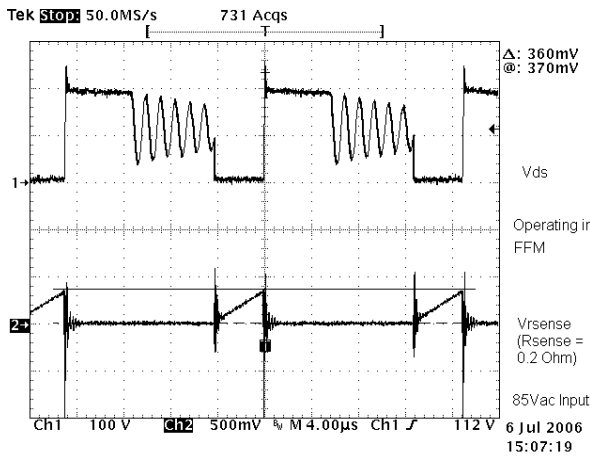

Figure 8.

Waveforms of V_{FB} , V_{OVP} , V_{CS} and V_{GATE}
 V_{FB} , V_{OVP} , V_{CS} and V_{GATE}

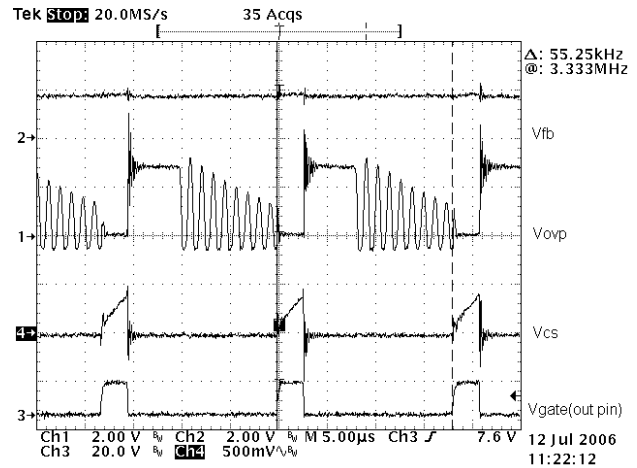

Figure 9.

EFFICIENCY
 VS
 LOAD POWER

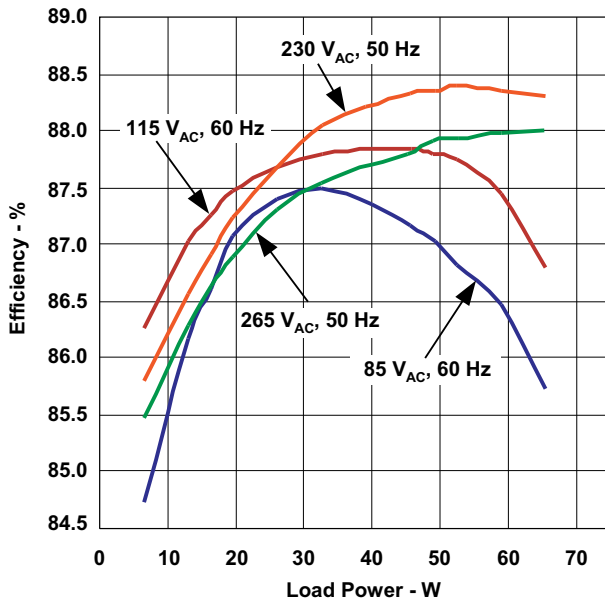

Figure 10.

EFFICIENCY
 VS
 INPUT VOLTAGE AT FULL LOAD

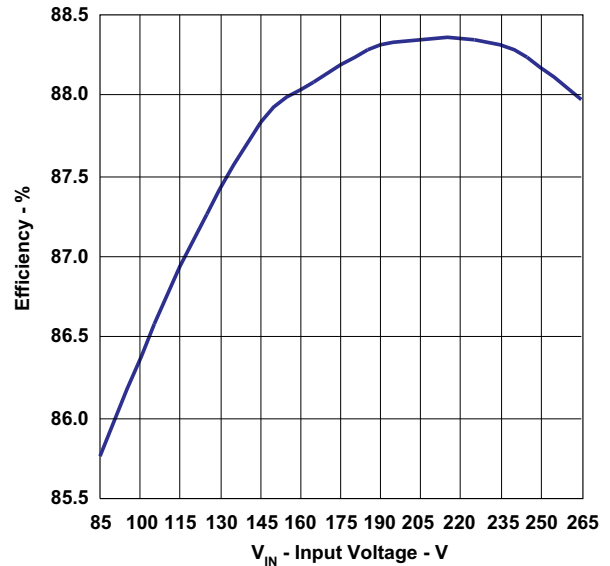

Figure 11.

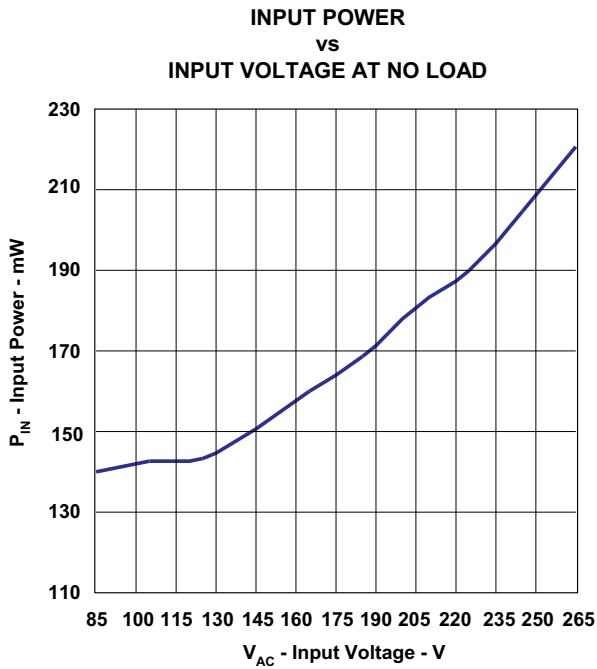

Figure 12.

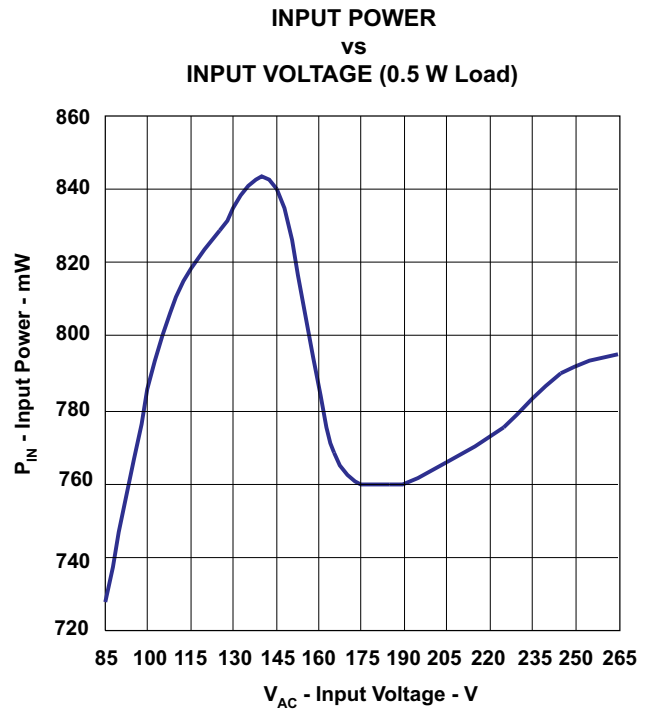

Figure 13.

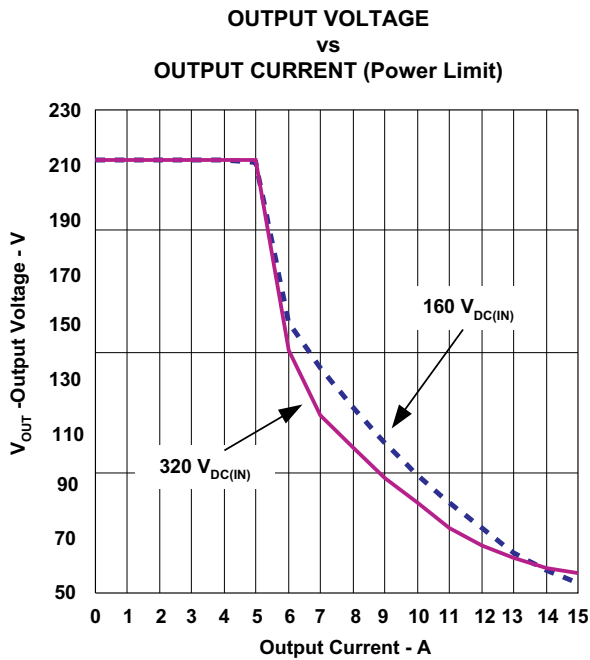

Figure 14.

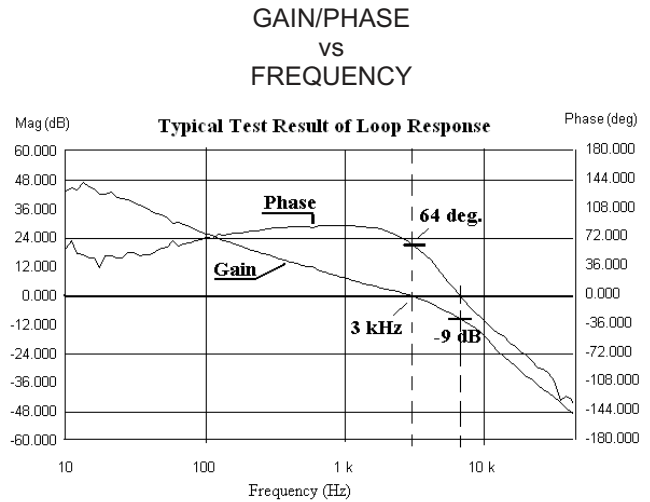

Figure 15.

5 EVM Assembly Drawing and Layout

Figure 16 and Figure 17 show the layout of the single-sided printed circuit board used for the EVM.

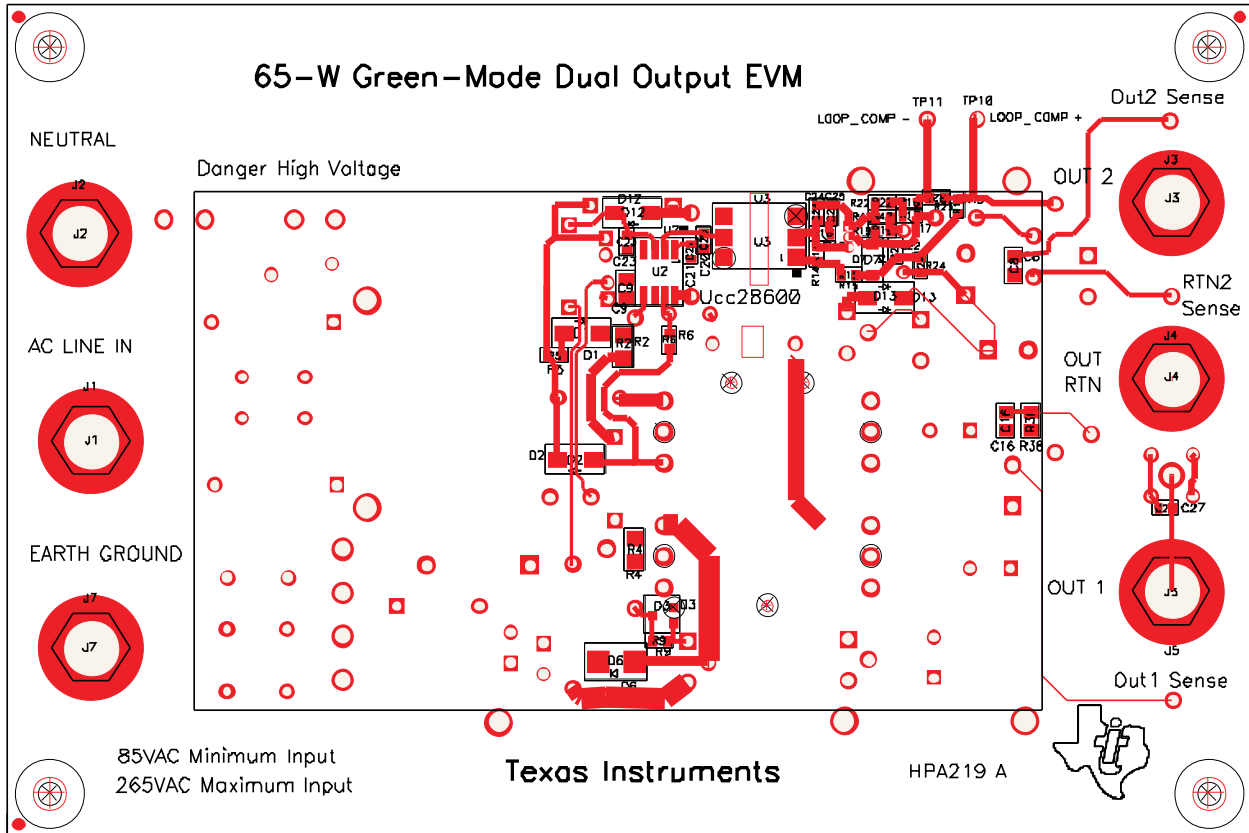

Figure 16. Top View

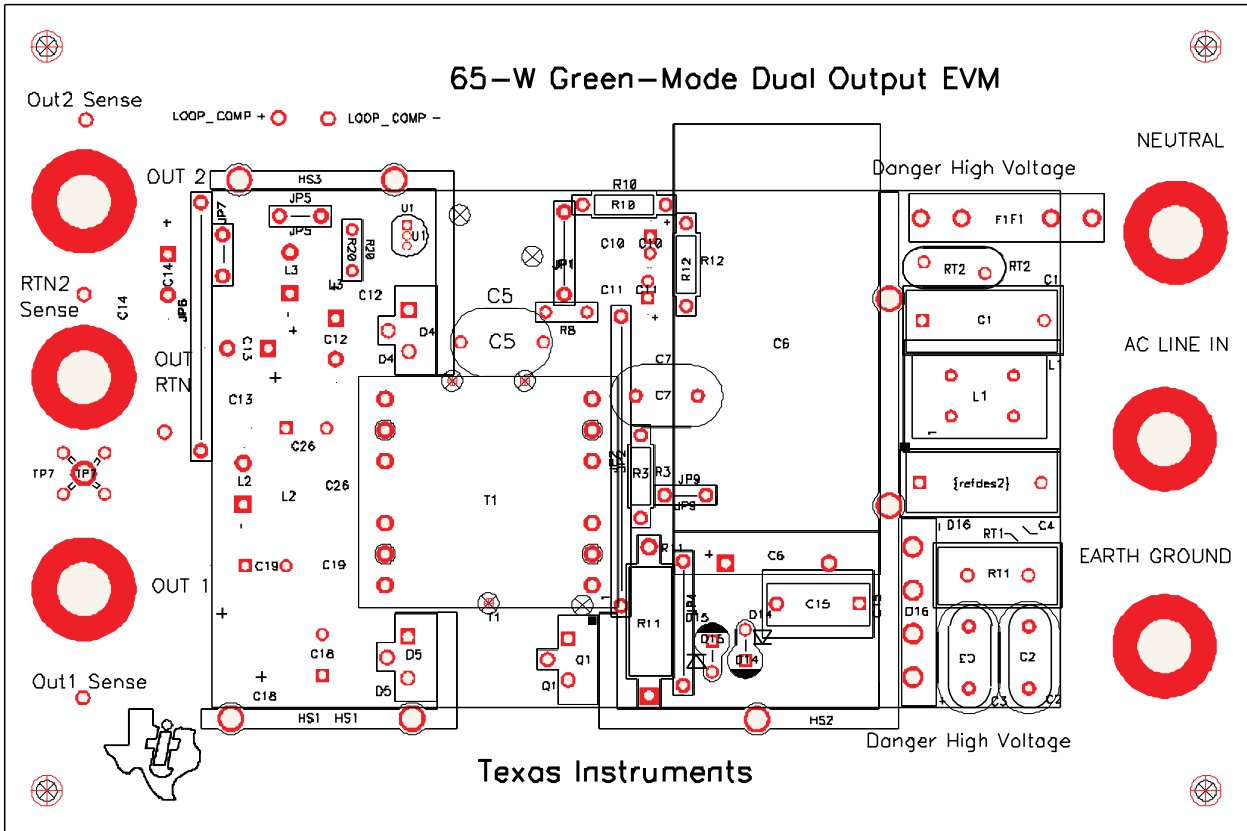

Figure 17. Bottom View

6 List of Materials

Table 2. List of Materials

RefDes	Qty	Description	MFR	Part Number
C1	1	Capacitor, film, 0.1 μ F, 275 V _{AC} , \pm 20%	Panasonic	ECQU2A104ML
C10	1	Capacitor, aluminum, 22 μ F, 50 V, \pm 20% (FC series)	Panasonic	EEU-FC1H100
C11	1	Capacitor, aluminum, 10 μ F, 50 V, \pm 20% (FC series)	Panasonic	EEU-FC1H100
C15	1	Capacitor, polyester, 0.01 μ F, 630 V, \pm 10%	Panasonic - ECG	ECQ-E6103KF
C18, C19, C26	3	Capacitor, aluminum, 1500 μ F, 25 V, \pm 20%	Panasonic	EEU-FC1E152
C2, C3	2	Y2 Capacitor, ceramic disc, 4700 pF, 250 V, \pm 20%	Murata	DE2E3KY472M
C20	1	Capacitor, ceramic, 390 pF, 50 V, X7R, \pm 10%	Murata Electronics	GRM188R71H391KA01D
C21	1	Capacitor, ceramic, 18 nF, 25 V, X7R, \pm 10%	Panasonic - ECG	ECJ-1VB1E183K
C22, C25	2	Capacitor, ceramic, 0.1 μ F, 16 V, X7R, \pm 10%	Kemet	C0603C104K4RACTU
C23	1	Capacitor, ceramic, 100 pF, 100 V, C0G, \pm 5%	Murata Electronics	GRM1885C2A101JA01D
C24	1	Capacitor, ceramic, 220 pF, 100 V, C0G, \pm 5%	Murata Electronics	GRM1885C2A221JA01D
C4	1	Capacitor, film, 0.1 μ F, 275 V _{AC} , \pm 20%	Panasonic	ECQU2A104ML
C5	1	Capacitor, ceramic disc, 150 pF, 4 kV, temp 15%, \pm 20%, Y1 class	Panasonic	ECKANA151MB
C6	1	Capacitor, aluminum, 120 μ F, 400 V, \pm 20%	Chemi-Con	ESMG401E121MN40SLL
C7	1	Capacitor, ceramic disc, 0.1 μ F, 50 V, X7R, \pm 20%	BC Components	K104K15X7RF5TH5
C16	1	Capacitor, ceramic, 0.1 μ F, 35 V, X5R, \pm 10%	Murata Electronics	GRM21B1H104K
C9	1	Capacitor, ceramic, 0.1 μ F, 50 V, X7R	Murata Electronics	GRM21BR71H104KA01K
D1, D2, D12	3	Diode, ultra fast rectifier, 1 A, 100 V	ON Semiconductor	MURA110T3
D14, D15	2	Diode,transient voltage suppressor, 68 V, 5 W	Vishay	P6KE68A
D16	1	Diode, bridge rectifier, 6 A, 400 V	Vishay	GBU6G
D3	1	Diode, Schottky, 1 A, 40 V	Central Semiconductor	ZHCS1000
D5	1	Diode, dual Schottky, 2 A x 10 A, 120 V	STMicroelectronics	STPS20120CT
D6	1	Diode, ultra fast rectifier, 2 A, 600 V	ON Semiconductor	MURS260T3
D7	1	Diode, Zener, 500 mW, 10 V	ON Semiconductor	MMSZ5240BT1G
F1	1	Fuse, axial, fast acting, 2 A, 250 V	Littelfuse	0263002.M
L1	1	Inductor, SMT, 1 mH, 3 A, 0.035 Ω , \pm 30%	JW Miller	7111JW
L2	1	Inductor, 8RHB2 type, 10 A, 1 μ H	JW Miller Magnetics	6000-1R0M-RC
Q1	1	MOSFET, cool MOS power N-channel, 650 V, 11 A, 380 m Ω ,	Infineon Technologies	SPP11N60C3
R10	1	Resistor, metal film, 210 k Ω , 1/4 W, \pm 1%, axial	Yageo America	MFR-25FBF-210K
R11	1	Resistor, metal film, 0.2 Ω , 3 W, \pm 5%, axial	KOA Speer Electronics	SPRX3CT520R20F
R12	1	Resistor, metal film, 1.69 k Ω , 1/4 W, \pm 1%, axial	Yageo America	MFR-25FBF-1K69
R13	1	Resistor, chip, 1.50 k Ω , 1/10 W, \pm 1%, 0603	Yageo America	RC0603FR-071K5L
R14	1	Resistor, chip, 499 Ω , 1/10 W, \pm 1%, 0603	Yageo America	RC0603FR-07215RL

Table 2. List of Materials (continued)

RefDes	Qty	Description	MFR	Part Number
R15	1	Resistor, chip, 499 Ω , 1/10 W, $\pm 1\%$, 0603	Yageo America	RC0603FR-07215RL
R16	1	Resistor, chip, 36.5 k Ω , 1/10 W, $\pm 1\%$, 0603	Yageo America	RC0603FR-0736K5L
R17, R19	2	Resistor, chip, 4.12 k Ω , 1/10 W, $\pm 1\%$, 0603	Yageo America	RC0603FR-074K12L
R18	1	Resistor, chip, 25.5 k Ω , 1/10 W, $\pm 1\%$, 0603	Yageo America	RC0603FR-0725k5L
R2	1	Resistor, chip, 680 k Ω , 1/4 W, $\pm 5\%$, 1206	Panasonic - ECG	ERJ-8GEYJ684V
R20	1	Resistor, metal film, 4.12 k Ω , 1/4 W, $\pm 5\%$	Yageo America	MFR-25FBF-4K12
R22	1	Resistor, chip, 0 Ω , 1/10 W, $\pm 1\%$, 0603	Yageo America	RC0603FR-070000L
R23	1	Resistor, chip, 50 Ω , 1/10 W, $\pm 1\%$, 0603	Yageo America	RC0603FR-074k12L
R3		Resistor, metal film, 680 k Ω , 1/4 W, 1%, Axial	Yageo America	MFR-25FBF-680K
R4		Resistor, chip, 680 k Ω , 1/4 W, $\pm 5\%$, 1206	Panasonic - ECG	ERJ-8GEYJ684V
R5	1	Resistor, chip, 20 Ω , 1/10 W, $\pm 5\%$, 0603	Panasonic - ECG	ERJ-3GEYJ200V
R6	1	Resistor, chip, 210 k Ω , 1/10 W, $\pm 1\%$, 0603	Rohm	MCR03EZPFX1603
R8	1	Resistor, Metal Film, 28.7 k Ω , 1/4 W, $\pm 5\%$	YAGEO	MFR-25FBF-28K7
R9	1	Resistor, chip, 10 Ω , 1/16 W, $\pm 1\%$, 0603	Panasonic - ECG	ERJ-3EKF10R0V
RT1	1	Thermistor, NTC, 5 Ω , 4.2 A	Epcos	B57235S0509M000
T1	1	XFMR, flyback	GCI	G065022LF
U1	1	Adj. precision shunt	Texas Instruments	TL431CLP
U2	1	Quasi-Resonant Flyback Green-Mode Controller	Texas Instruments	UCC28600D
U3	1	Optocoupler, NPN with base	Vishay	CNY17-1X007

7 References

1. *UCC28600 8-pin quasi-resonant flyback green mode controller*, datasheet, TI literature Number [SLUS646B](#), May 2006
2. *Test method for calculating the energy efficiency of single-voltage ac-dc and ac-ac power supplies*, California Energy Commission, August 11, 2004
3. *Standby and Low Power Measurements*, Voltech Notes, VPN 104-054/1
4. *Design Consideration for the UCC28600*, Application Note, TI literature Number [SLUA399](#)

IMPORTANT NOTICE

Texas Instruments Incorporated and its subsidiaries (TI) reserve the right to make corrections, modifications, enhancements, improvements, and other changes to its products and services at any time and to discontinue any product or service without notice. Customers should obtain the latest relevant information before placing orders and should verify that such information is current and complete. All products are sold subject to TI's terms and conditions of sale supplied at the time of order acknowledgment.

TI warrants performance of its hardware products to the specifications applicable at the time of sale in accordance with TI's standard warranty. Testing and other quality control techniques are used to the extent TI deems necessary to support this warranty. Except where mandated by government requirements, testing of all parameters of each product is not necessarily performed.

TI assumes no liability for applications assistance or customer product design. Customers are responsible for their products and applications using TI components. To minimize the risks associated with customer products and applications, customers should provide adequate design and operating safeguards.

TI does not warrant or represent that any license, either express or implied, is granted under any TI patent right, copyright, mask work right, or other TI intellectual property right relating to any combination, machine, or process in which TI products or services are used. Information published by TI regarding third-party products or services does not constitute a license from TI to use such products or services or a warranty or endorsement thereof. Use of such information may require a license from a third party under the patents or other intellectual property of the third party, or a license from TI under the patents or other intellectual property of TI.

Reproduction of TI information in TI data books or data sheets is permissible only if reproduction is without alteration and is accompanied by all associated warranties, conditions, limitations, and notices. Reproduction of this information with alteration is an unfair and deceptive business practice. TI is not responsible or liable for such altered documentation. Information of third parties may be subject to additional restrictions.

Resale of TI products or services with statements different from or beyond the parameters stated by TI for that product or service voids all express and any implied warranties for the associated TI product or service and is an unfair and deceptive business practice. TI is not responsible or liable for any such statements.

TI products are not authorized for use in safety-critical applications (such as life support) where a failure of the TI product would reasonably be expected to cause severe personal injury or death, unless officers of the parties have executed an agreement specifically governing such use. Buyers represent that they have all necessary expertise in the safety and regulatory ramifications of their applications, and acknowledge and agree that they are solely responsible for all legal, regulatory and safety-related requirements concerning their products and any use of TI products in such safety-critical applications, notwithstanding any applications-related information or support that may be provided by TI. Further, Buyers must fully indemnify TI and its representatives against any damages arising out of the use of TI products in such safety-critical applications.

TI products are neither designed nor intended for use in military/aerospace applications or environments unless the TI products are specifically designated by TI as military-grade or "enhanced plastic." Only products designated by TI as military-grade meet military specifications. Buyers acknowledge and agree that any such use of TI products which TI has not designated as military-grade is solely at the Buyer's risk, and that they are solely responsible for compliance with all legal and regulatory requirements in connection with such use.

TI products are neither designed nor intended for use in automotive applications or environments unless the specific TI products are designated by TI as compliant with ISO/TS 16949 requirements. Buyers acknowledge and agree that, if they use any non-designated products in automotive applications, TI will not be responsible for any failure to meet such requirements.

Following are URLs where you can obtain information on other Texas Instruments products and application solutions:

Products		Applications	
Amplifiers	amplifier.ti.com	Audio	www.ti.com/audio
Data Converters	dataconverter.ti.com	Automotive	www.ti.com/automotive
DLP® Products	www.dlp.com	Communications and Telecom	www.ti.com/communications
DSP	dsp.ti.com	Computers and Peripherals	www.ti.com/computers
Clocks and Timers	www.ti.com/clocks	Consumer Electronics	www.ti.com/consumer-apps
Interface	interface.ti.com	Energy	www.ti.com/energy
Logic	logic.ti.com	Industrial	www.ti.com/industrial
Power Mgmt	power.ti.com	Medical	www.ti.com/medical
Microcontrollers	microcontroller.ti.com	Security	www.ti.com/security
RFID	www.ti-rfid.com	Space, Avionics & Defense	www.ti.com/space-avionics-defense
RF/IF and ZigBee® Solutions	www.ti.com/lprf	Video and Imaging	www.ti.com/video
		Wireless	www.ti.com/wireless-apps