

# SERPAC CA10B0 Electronic Enclosures (no buttons option)

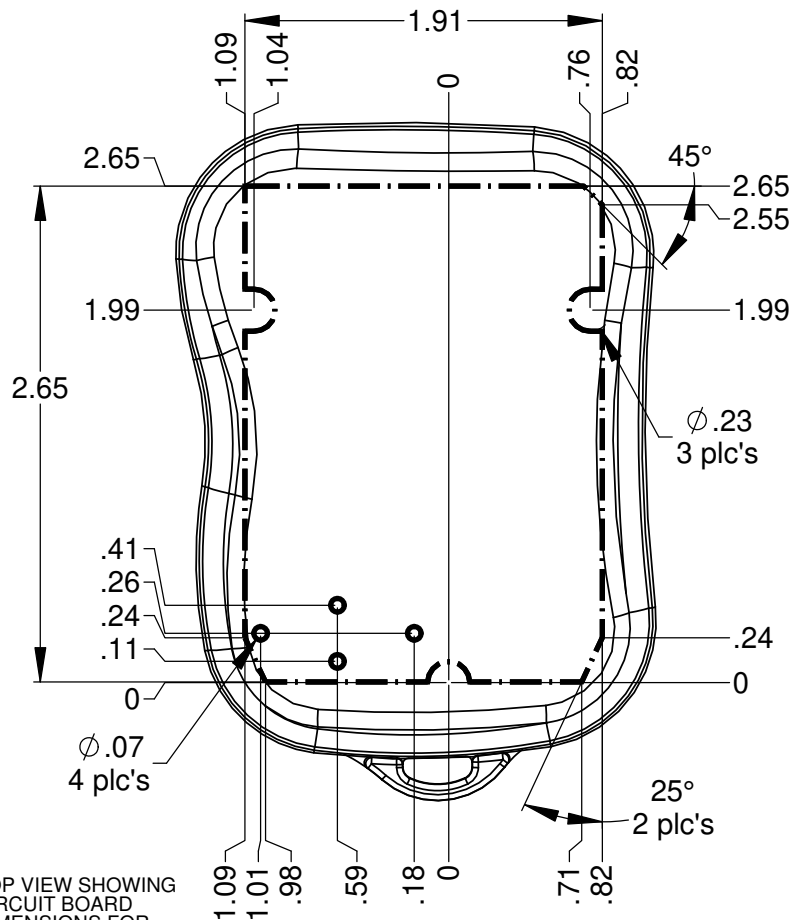

TOP VIEW SHOWING  
CIRCUIT BOARD  
DIMENSIONS FOR  
20mm COIN BATTERY

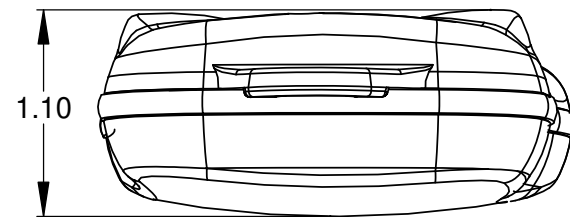
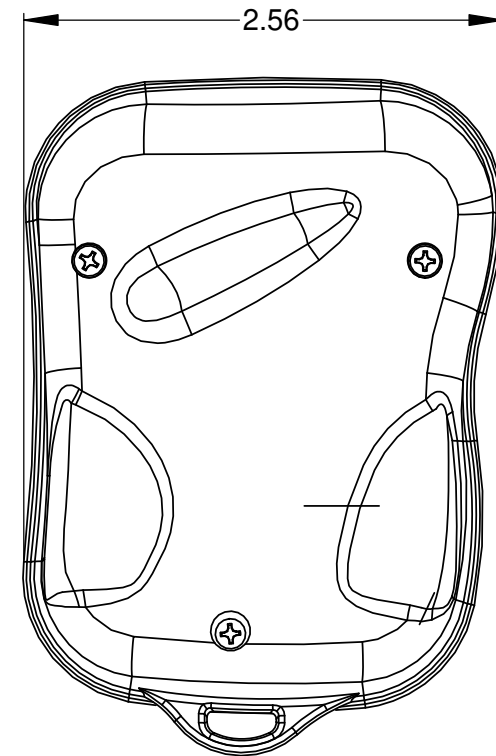
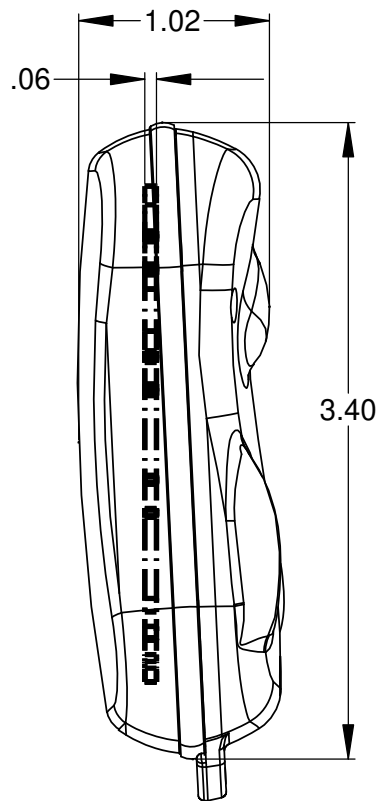

**NOTES:**

- 1) Serpac Provides the following components:  
Top, Bottom, Button Membrane, 9mm keyring and (2) #2 Screws.  
All components are shipped unassembled.
- 2) The switches characteristics recommended for this enclosure are:  
- 4.3 mm in height from mounting surface to top of push plate.  
- Operating force recommended is 1.6 N or more.
- 3) For battery contacts use:  
- for Coin battery Keystone 3003 positive and 2990 negative

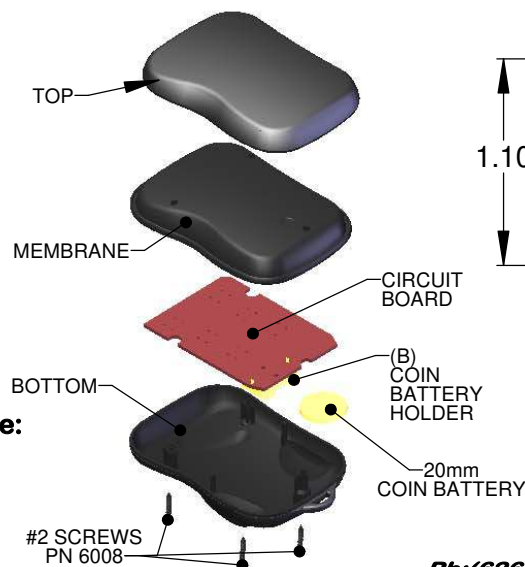

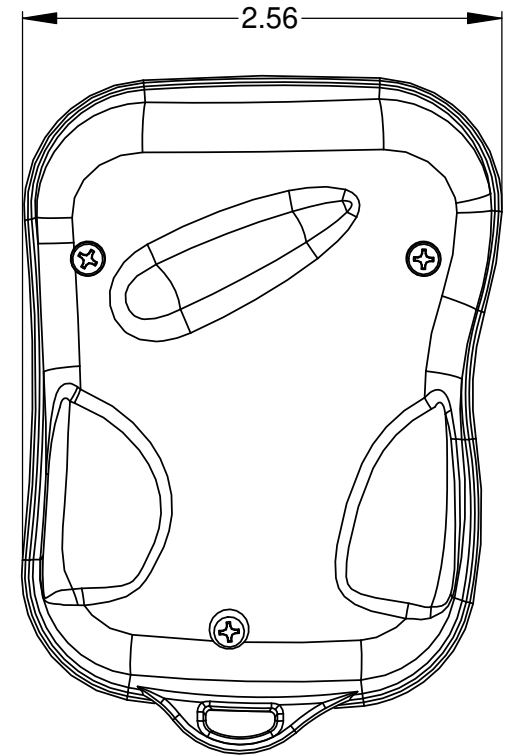
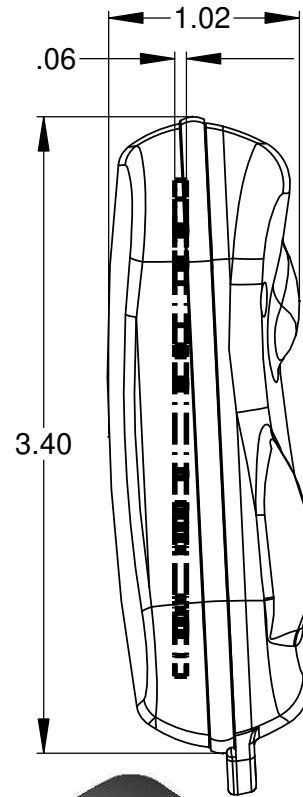
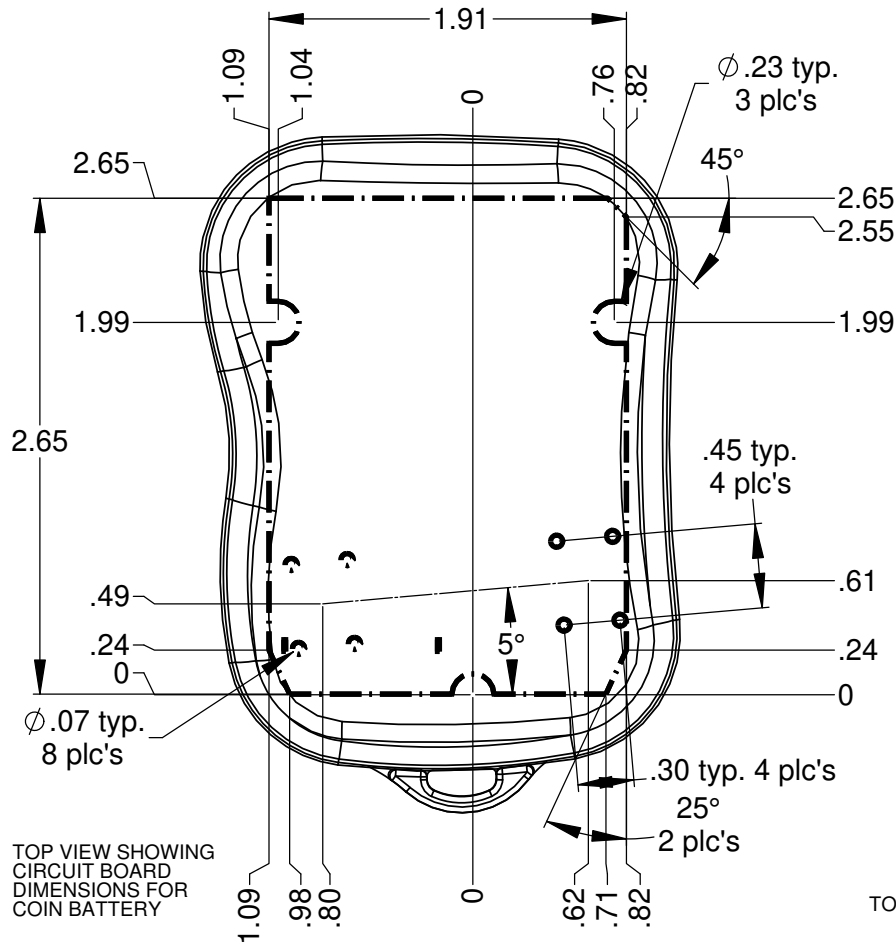

TOP VIEW SHOWING  
CIRCUIT BOARD  
DIMENSIONS FOR  
COIN BATTERY

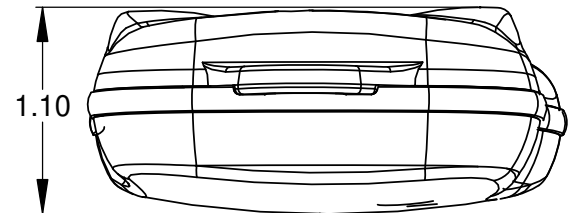
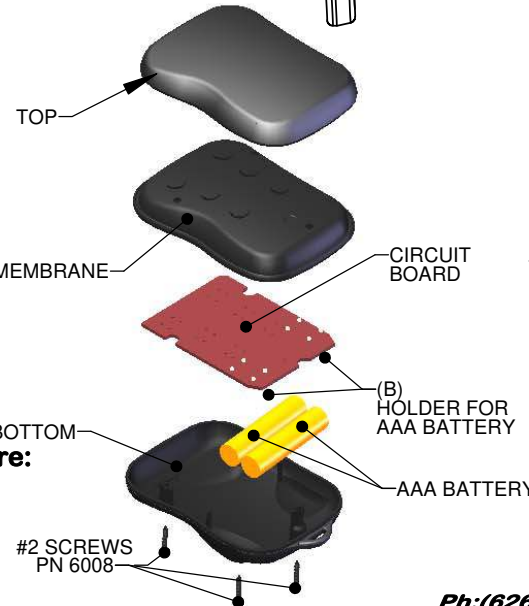

**NOTES:**

- 1) Serpac Provides the following components:  
Top, Bottom, Button Membrane, 9mm keyring and (2) #2 Screws.  
All components are shipped unassembled.
- 2) The switches characteristics recommended for this enclosure are:  
- 4.3 mm in height from mounting surface to top of push plate.  
- Operating force recommended is 1.6 N or more.
- 3) For battery contacts use:  
- for (2) AAA Batteries use Keystone 82 (2 per battery)