

Bottom view

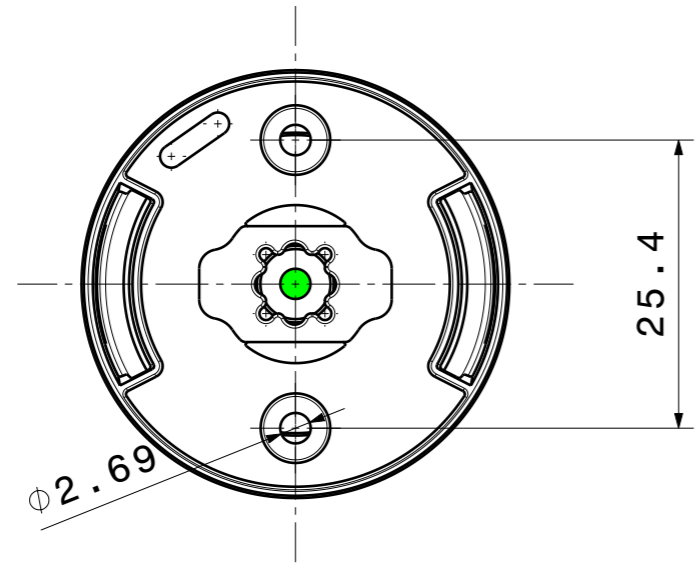

Isometric view
Scale 2:1

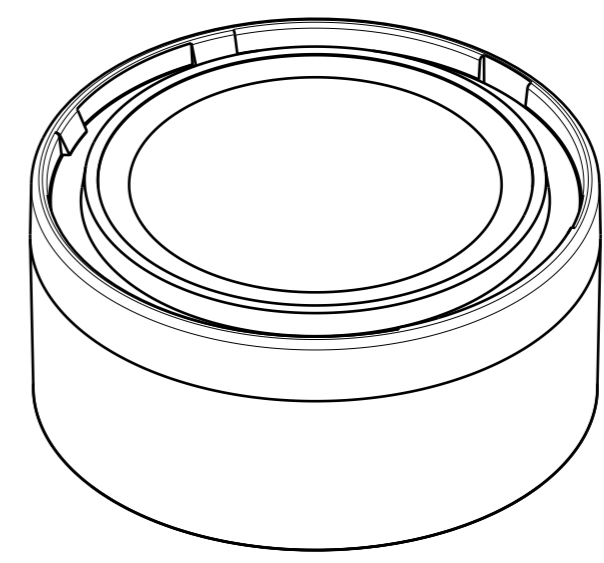

Front view



Top view

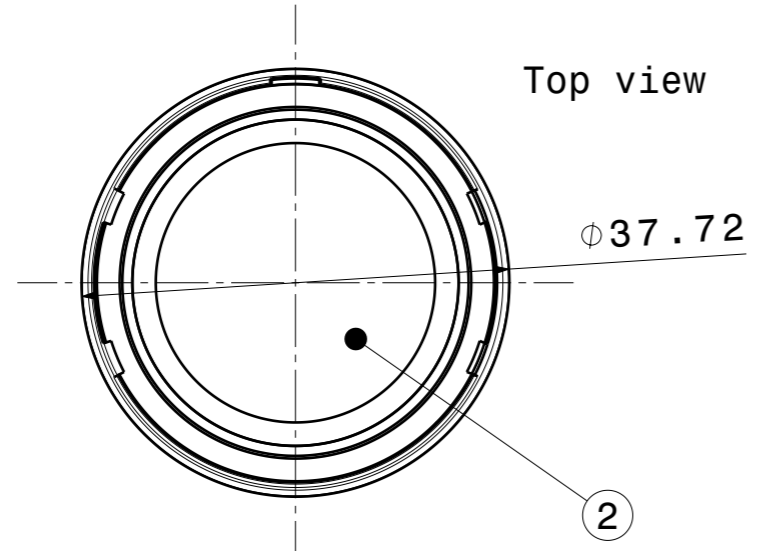

INDEX	PART	TYPE	MATERIAL	COLOR / COATING
1	C12053_EVA-HLD-XM	HOLDER	PC	BLACK
2	-	LENS	PMMA	CLEAR

MECHANICAL DRAWING		LEDiL [®]
PRODUCT EVA-XM-HLD_DATASHEET		
Plastic moulding general tolerances according to DIN 16901-130 and applies if not otherwise shown in the drawing. Silicone moulding general tolerances according to ISO 3302-1 Class M3 and applies if not otherwise shown in the drawing.	FIRST ANGLE PROJECTION: 	This drawing is the property of LEDiL Oy. It may not be copied or otherwise distributed without prior written permission from LEDiL Oy.
SCALE 3:2	WEIGHT -	A3 SHEET 1/1

Notes

- LED location
- Ensure LED fitting from a product specific 3D model available from www.ledil.com
- For more details about installation please see LEDiL Installation Guide on www.ledil.com