

REVISIONS			
REV.	DESCRIPTION	DATE	APPROVED
A	INITIAL RELEASE	03/10/15	N.D.

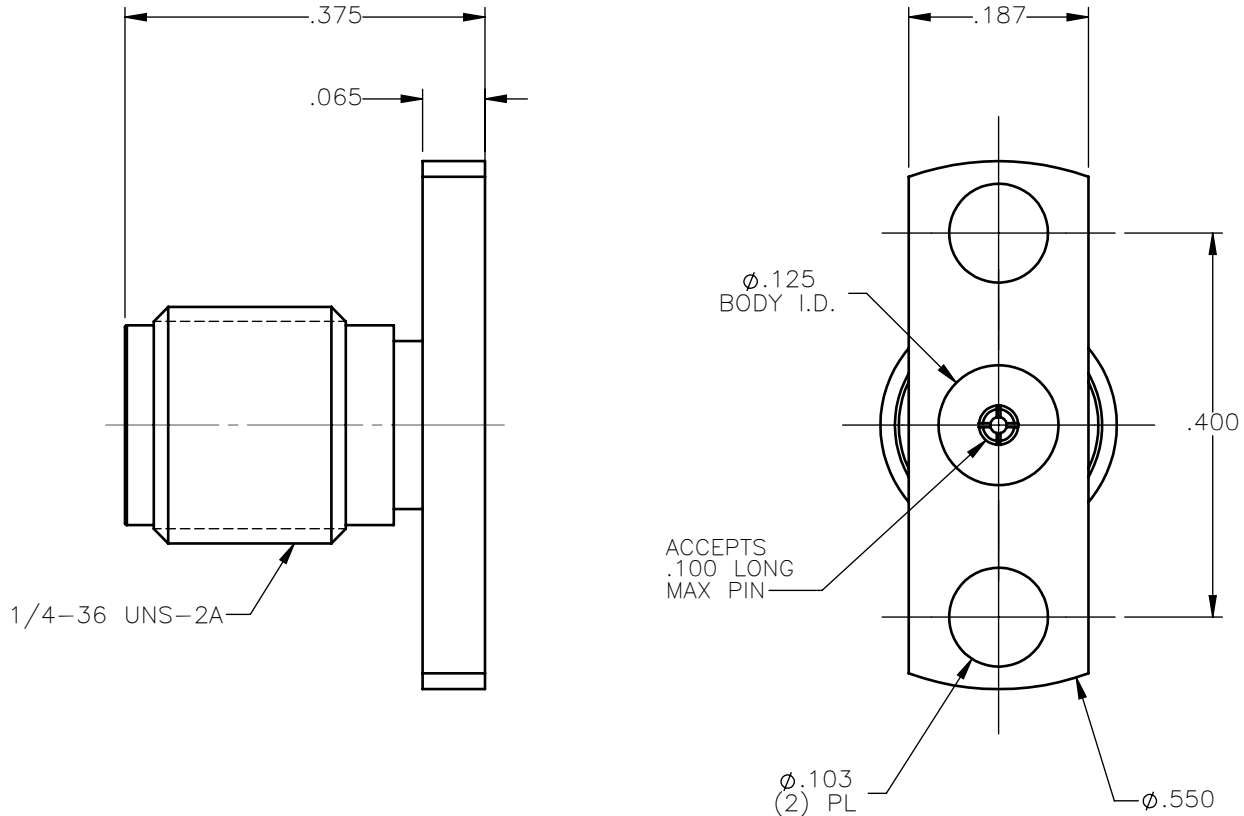

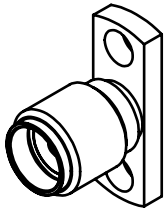

NOTES:

MATERIALS:

1. BODY = STAINLESS STEEL PER ASTM A582, ALLOY 303, CONDITION "A".
2. INSULATOR = VIRGIN WHITE TEFLON PER ASTM D1710, GRADE 1, TYPE I, CLASS "B".
3. CONTACT = BERYLLIUM COPPER PER ASTM B196, ALLOY C17300, TEMPER TD04.

FINISHES:

1. BODY = PASSIVATE PER SAE-AMS-2700
2. CONTACT = GOLD PLATE PER ASTM B488-01, TYPE II, 50µin MIN, GRADE C, OVER 100 TO 200µin STRESS FREE SULFAMATE NICKEL PER QQ-N-290.

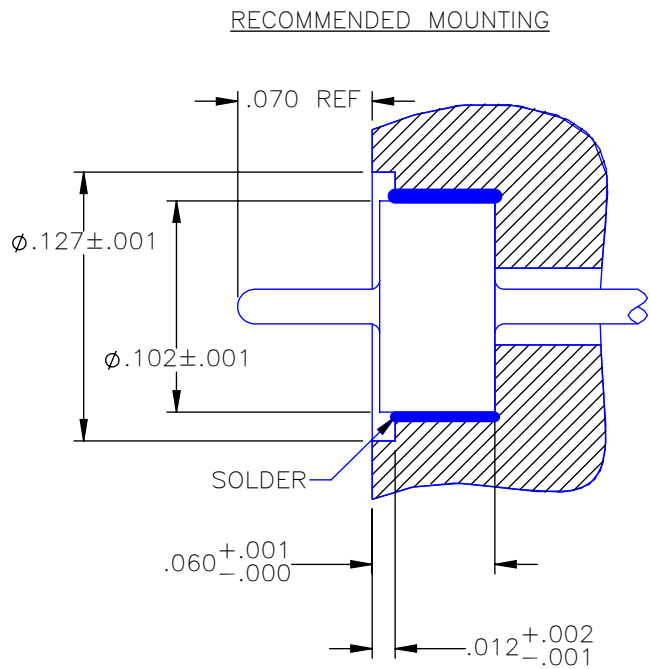
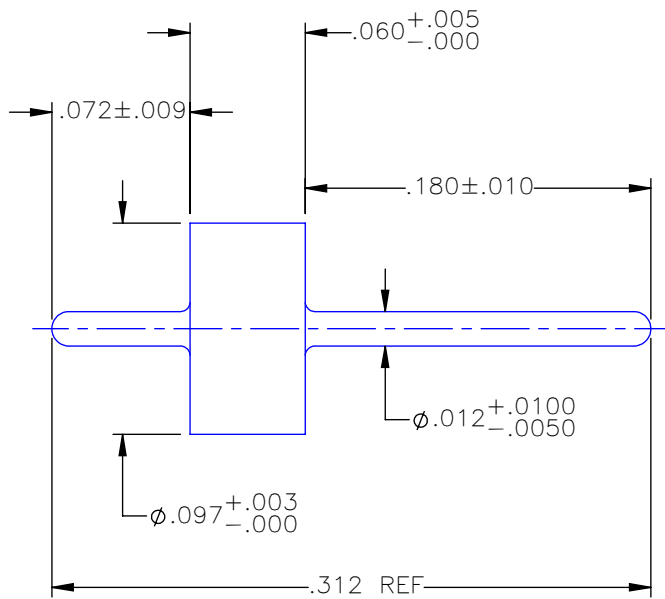

UNLESS OTHERWISE SPECIFIED DIMENSIONS ARE IN INCHES TOLERANCES ON	DWN: N.D.	DATE 03/10/15	 Property of Radiall This document cannot be reproduced or communicated to a third party without prior written permission of RADIALL.			
	CHKD: D.N.	DATE 03/10/15				
DECIMAL	ANGLE	APVD: J.M.	<b>SMA STRAIGHT JACK TWO HOLE FLANGE MOUNT WITH GLASS SEAL</b>			
		DATE 03/10/15				
REFERENCE:	MATERIALS AND FINISHES: SEE NOTES		SIZE A	FSCM NO. 19505	DWG NO. 9180-9513-000	REV A
ORIGINATED: N.D. DATE: 03/10/15			SCALE 5:1	THIRD ANGLE PROJECTION		SHEET 1 OF 2

9180-9513-000



MATERIALS: OUTER RING AND PIN = KOVAR  
GLASS BEAD = CORNING 7070

FINISHES: OUTER RING AND PIN = GOLD PLATE PER ASTM B488-01, TYPE II, GRADE C, 50 $\mu$ in  
OVER NICKEL PER MIL-C-26074, 50 $\mu$ in THICK OVER COPPER PER MIL-C-14550.

UNLESS OTHERWISE SPECIFIED DIMENSIONS ARE IN INCHES TOLERANCES ON	DWN: N.D.	DATE 03/10/15	 Property of Radiall This document cannot be reproduced or communicated to a third party without prior written permission of RADIALL.		
	CHKD: D.N.	DATE 03/10/15			
DECIMAL	ANGLE	APVD: J.M.	DATE 03/10/15	SMA STRAIGHT JACK TWO HOLE FLANGE MOUNT WITH GLASS SEAL	
REFERENCE:	MATERIALS AND FINISHES: SEE NOTES	SIZE A	FSCM NO. 19505		
ORIGINATED: N.D. DATE: 03/10/15		SCALE 4:1	THIRD ANGLE PROJECTION		SHEET 2 OF 2

9180-9513-000