

NOTES

1. MATERIAL : SEE TABLE
2. USED WITH TERMINAL : 35053-9002
3. MATED WITH FEMALE HOUSING : 35155-***0

LEGEND

35184 - ** * *
 COLOR : 0 --- NATURAL
 2 --- RED
 0 : PA66 / 9 : PBT/PC
 CKT NO.

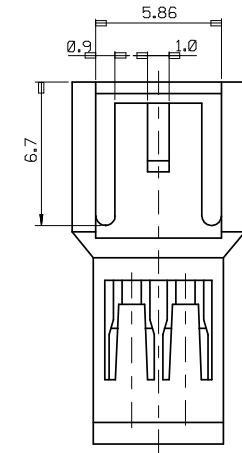

2.3 CKT ONLY

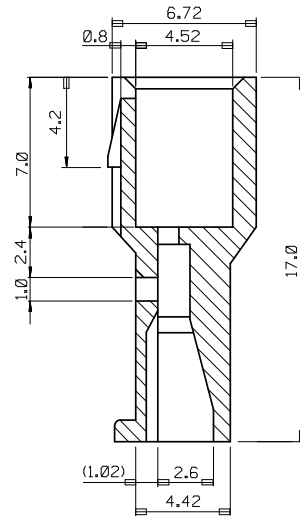

SECTION E-E

35.0	38.36	40.56	3518415**	35184-15 *	15
32.5	35.86	38.06	3518414**	-14**	14
30.0	33.36	35.56	3518413**	-13**	13
27.5	30.86	33.06	3518412**	-12**	12
25.0	28.36	30.56	3518411**	-11**	11
22.5	25.86	28.06	3518410**	-10**	10
20.0	23.36	25.56	3518409**	-09**	9
17.5	20.86	23.06	3518408**	-08**	8
15.0	18.36	20.56	3518407**	-07**	7
12.5	15.86	18.06	3518406**	-06**	6
10.0	13.36	15.56	3518405**	-05**	5
7.5	10.86	13.06	3518404**	-04**	4
5.0	8.36	10.56	3518403**	-03**	3
2.5	5.86	8.06	3518402**	35184-02**	2
C	B	(A)	MATERIAL NO	ENG. NO	CKT

REVISED EC NO: KOR2008-0103 DRWN:SKHAN01 2007/12/24 CHKD:WY. YANG 2007/12/24 APPR: YUNS IKK IM 2007/12/24	QUALITY SYMBOLS ▽=0 ▽C=0	GENERAL TOLERANCES (UNLESS SPECIFIED)		DIMENSION STYLE MM ONLY		SCALE 4:1	DESIGN UNITS METRIC	THIRD ANGLE PROJECTION	
		4 PLACES ± --- ± ---	3 PLACES ± --- ± ---	2 PLACES ± --- ± ---	1 PLACE ± 0.3 ± ---	DRAWN BY SK. HAN	DATE 2007/12/13	TITLE 2.5 PITCH W/W CONN. MALE HOUSING	
REV	DESCRIPTION	ANGULAR ± 2 °		APPROVED BY EH. JUNG		DATE 2007/12/13	MATERIAL NO. SD-35184-***0*		
		DRAFT WHERE APPLICABLE MUST REMAIN WITHIN DIMENSIONS		SEE TABLE		DOCUMENT NO.	SHEET NO. 1 OF 1		
		SIZE A3		THIS DRAWING CONTAINS INFORMATION THAT IS PROPRIETARY TO MOLEX INCORPORATED AND SHOULD NOT BE USED WITHOUT WRITTEN PERMISSION					