

THIS DRAWING IS UNPUBLISHED. RELEASED FOR PUBLICATION
 © COPYRIGHT - By - ALL RIGHTS RESERVED.

LOC		DIST		REVISIONS			
P	LTR	DESCRIPTION	DATE	DWN	APVD		
	B	ECO-11-003677	21APR2011	RZ	YM		

- 1 BRASS
- 2 BERYLLIUM COPPER
- 3 PTFE
- 4 GOLD PLATE
- 5 STAINLESS STEEL
- 6 PASSIVATE
- 7 SILICONE RUBBER

DESIGNED FOR USE WITH
RG-180/U & 190 CABLE

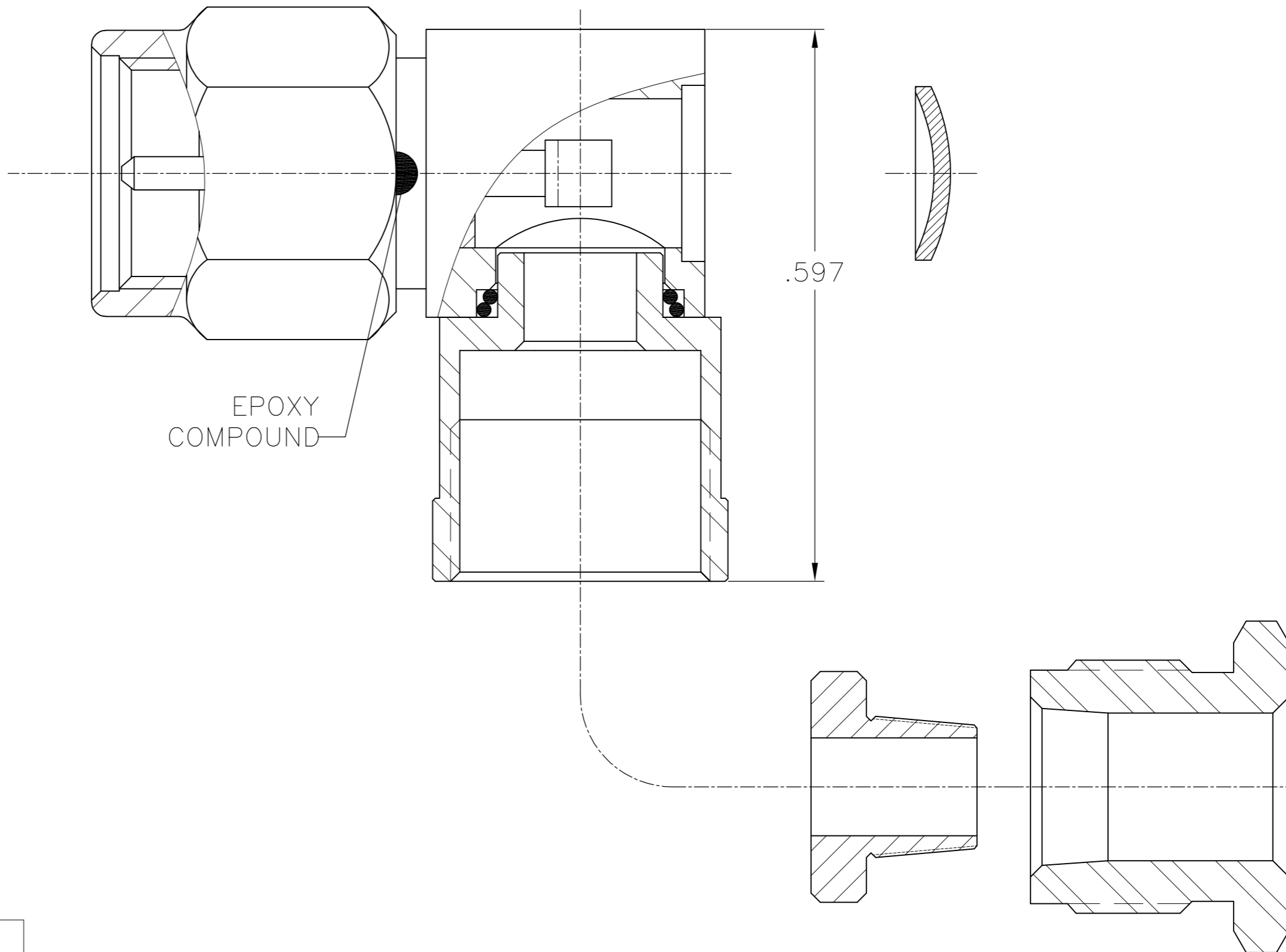

ELECTRICAL	MECHANICAL	ENVIRONMENTAL
Nominal Impedance (Ohms) 50	Interface Dimensions MIL-STD-348A, Fig. 310.1	TEMPERATURE RATING -65° TO +165°
Frequency Range (GHz) DC to 12.4	Recommended Mating Torque 7-10 In-Lbs	Vibration MIL-STD-202, Method 204, Condition D
Volt Rating (VRMS MAX) @ Sea Level 335	Mating Characteristics:	Shock MIL-STD-202, Method 213, Condition I
VSWR 1.15 + .01f(GHz)	Insertion (MAX Lbs) N/A	Thermal Shock MIL-STD-202, Method 107, Condition B
Insertion Loss (dB MAX) .06 f(GHz)	Withdrawal (MIN Oz) N/A	Moisture Resistance MIL-STD-202, Method 106
RF Leakage (dB MIN) -[60-f(GHz)]	Force to Engage and Disengage (In-Lbs MAX) 2	Corrosion - MIL-STD-202, Method 101, Condition B, 5% salt spray
Corona, 70,000 Ft (VRMS MIN) 250	Center Contact Captivation	.XXX = in
Dielectric Withstanding Voltage (VRMS MIN) @ Sea Level 1,000	Axial (Lbs) 6 Min	XX.X = mm
Contact Resistance (Milliohms MAX)	Radial (In-Dz) N/A	THE QUALIFICATION TESTING HAVE NOT BEEN COMPLETED.
Center Contact 3.0	Cable Retention	
Outer Contact 2.0	Axial Force (Lbs) 45 MIN	
Cable to Housing 0.5	Torque (In-Oz) N/A	
RF High Potential @ Sea Level (VRMS MIN @ 5 MHz) 670	Weight (Grams) TBD	
I.R.(Megohms MIN) 5,000		

5 6	5 6	5 6	1 4	1 4	3	2	1	5 6	1051144-1
HOUSING	CAP	CLAMP NUT	COLLAR	MALE CONTACT	DIELECTRIC	RETAINING RING	GASKET	COUPLING NUT	PART NO.
THIS DRAWING IS A CONTROLLED DOCUMENT.						DWN TITAN DAI 21APR2011		TE Connectivity	
DIMENSIONS: INCHES						CHK RITA ZUO 21APR2011		NAME	
TOLERANCES UNLESS OTHERWISE SPECIFIED:						APVD MARTIN YE 21APR2011		OSM RIGHT ANGLE CABLE PLUG CLAMP ATTACHMENT	
0 PLC ± -						PRODUCT SPEC		DRAWING NO	
1 PLC ± -						APPLICATION SPEC		RESTRICTED TO	
2 PLC ± -						408-4965		SIZE	
3 PLC ± .010						WEIGHT		CAGE CODE	
4 PLC ± -						A2 00779		DRAWING NO	
ANGLES ± -						CUSTOMER DRAWING		SCALE	
FINISH						8:1		SHEET	
						1 OF 1		REV	
						B			