

Am54S/74S242 • Am54S/74S243

Quad Bus Transceivers with Three-State Outputs

DISTINCTIVE CHARACTERISTICS

- Three-state outputs drive bus lines directly
- Advanced Schottky processing
- Hysteresis at inputs improve noise margin
- PNP inputs reduce D.C. loading on bus lines
- V_{OL} of 0.55V at 64mA for Am74S; 48mA for Am54S
- Data-to-output propagation delay times:
Am54S/74S242 Inverting – 7.0ns MAX
Am54S/74S243 Noninverting – 9.0ns MAX
- Enable-to-output – 15.0ns MAX
- 100% reliability assurance testing in compliance with MIL-STD-883

FUNCTIONAL DESCRIPTION

The Am54S/74S242 and Am54S/74S243 are quad bus transceivers designed for asynchronous two-way communications between data buses.

The Am54S/74S242 and Am54S/74S243 have the two 4-line data paths connected input-to-output on both sides to form an asynchronous transceiver/buffer with complementing enable inputs. The Am54S/74S242 is inverting, while the Am54S/74S243 presents noninverting data at the outputs. The outputs of the commercial temperature range versions have 64mA sink and 15mA source capability, which can be used to drive terminated lines down to 133Ω. The outputs of the military temperature range versions have 48mA sink and 12mA source current capability.

Featuring 0.2V minimum guaranteed hysteresis at each low-current PNP data input, they provide improved noise rejection and high-fan-out outputs to restore Schottky TTL levels completely.

LOGIC DIAGRAMS

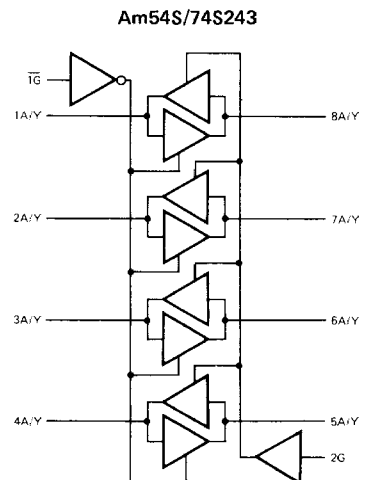
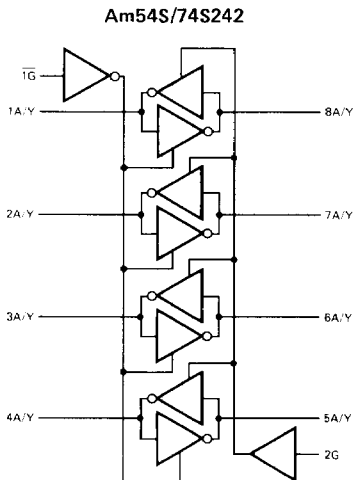

CONNECTION DIAGRAMS Top Views

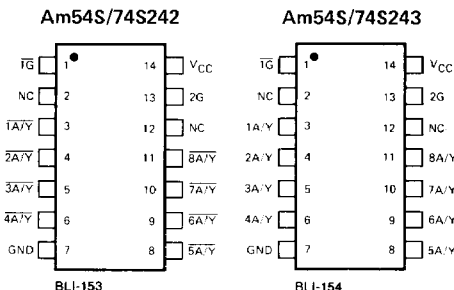

Note: Pin 1 is marked for orientation.

ORDERING INFORMATION

| Package Type | Temperature Range | Am54S/74S242 Order Number | Am54S/74S243 Order Number |
|--------------|-------------------|---------------------------|---------------------------|
| Hermetic | -55 to +125°C | SN54S242J | SN54S243J |
| Dice | -55 to +125°C | AM54S242X | AM54S243X |
| Hermetic | 0 to +70°C | SN74S242J | SN74S243J |
| Molded | 0 to +70°C | | |
| Dice | 0 to +70°C | AM74S242X | AM74S243X |

ELECTRICAL CHARACTERISTICS

The Following Conditions Apply Unless Otherwise Noted:

n54S242/S243 (MIL) $T_A = -55$ to $+125^\circ\text{C}$ $V_{CC}(\text{MIN.}) = 4.50\text{V}$ $V_{CC}(\text{MAX.}) = 5.50\text{V}$
 n74S242/S243 (COM'L) $T_A = 0$ to $+70^\circ\text{C}$ $V_{CC}(\text{MIN.}) = 4.75\text{V}$ $V_{CC}(\text{MAX.}) = 5.25\text{V}$

| Parameter | Description | Test Conditions (Note 1) | Typ. (Note 2) | | | Units | |
|-----------|--|--|--|---------------------|-------|---------------|----|
| | | | Min. | Max. | Units | | |
| V_{IH} | High-Level Input Voltage | | 2.0 | | | Volts | |
| V_{IL} | Low-Level Input Voltage | | | | 0.8 | Volts | |
| V_{IK} | Input Clamp Voltage | $V_{CC} = \text{MIN.}, I_I = -18\text{mA}$ | | | -1.2 | Volts | |
| | Hysteresis ($V_{T+} - V_{T-}$) | $V_{CC} = \text{MIN.}$ | 0.2 | 0.4 | | Volts | |
| V_{OH} | High-Level Output Voltage | $V_{CC} = \text{MIN.}, V_{IL} = 0.8\text{V}$ $I_{OH} = -3.0\text{mA}$ | 2.4 | 3.4 | | Volts | |
| | | $V_{CC} = \text{MIN.}, I_{OH} = -12\text{mA}$ | 2.0 | | | | |
| | | $V_{IL} = 0.5\text{V}$ MIL, $I_{OH} = -15\text{mA}$ COM'L, $I_{OH} = -15\text{mA}$ | 2.0 | | | | |
| V_{OL} | Low-Level Output Voltage | $V_{CC} = \text{MIN.}$ MIL, $I_{OL} = 48\text{mA}$ | | | 0.55 | Volts | |
| | | COM'L, $I_{OL} = 64\text{mA}$ | | | 0.55 | | |
| I_{OZH} | Off-State Output Current, High Level Voltage Applied | $V_{CC} = \text{MAX.}$ $V_{IH} = 2.0\text{V}$ | | $V_O = 2.4\text{V}$ | 50 | μA | |
| I_{OZL} | Off-State Output Current, Low-Level Voltage Applied | $V_{IL} = 0.8\text{V}$ | | $V_O = 0.5\text{V}$ | -50 | | |
| I_I | Input Current at Maximum Input Voltage | $V_{CC} = \text{MAX.}, V_I = 5.5\text{V}$ | | | 1.0 | mA | |
| I_{IH} | High-Level Input Current, Any Input | $V_{CC} = \text{MAX.}, V_{IH} = 2.7\text{V}$ | | | 50 | μA | |
| I_{IL} | Low-Level Input Current | Any A | | | -400 | μA | |
| | | Any G | $V_{CC} = \text{MAX.}, V_{IL} = 0.5\text{V}$ | | | -2.0 | mA |
| I_{OS} | Short-Circuit Output Current (Note 3) | $V_{CC} = \text{MAX.}$ | -50 | | -225 | mA | |
| I_{CC} | Supply Current | Am54S/74S242 | $V_{CC} = \text{MAX.}$ Outputs open | MIL | 80 | 123 | mA |
| | | | | COM'L | 80 | 135 | |
| | | | | MIL | 100 | 145 | |
| | | | | COM'L | 100 | 150 | |
| | | | | MIL | 100 | 145 | |
| | | | | COM'L | 100 | 150 | |
| | | Am54S/74S243 | $V_{CC} = \text{MAX.}$ Outputs open | MIL | 95 | 147 | mA |
| | | | | COM'L | 95 | 160 | |
| | | | | MIL | 120 | 170 | |
| | | | | COM'L | 120 | 180 | |
| | | | | MIL | 120 | 170 | |
| | | | | COM'L | 120 | 180 | |

- otes: 1. For conditions shown as MIN. or MAX., use the appropriate value specified under recommended operating conditions.
 2. All typical values are $V_{CC} = 5.0\text{V}$, $T_A = 25^\circ\text{C}$.
 3. Not more than one output should be shorted at a time, and duration of the short-circuit should not exceed one second.

MATCHING CHARACTERISTICS ($V_{CC} = 5\text{V}$, $T_A = 25^\circ\text{C}$)

| Parameter | Description | Test Conditions | Am54S/74S242 | | | Am54S/74S243 | | | Units |
|-----------|--|---|--------------|------|------|--------------|------|------|-------|
| | | | Min. | Typ. | Max. | Min. | Typ. | Max. | |
| t_{PLH} | Propagation Delay Time, Low-to-High-Level Output | $C_L = 50\text{pF}, R_L = 90\Omega$ (Note 3) | | 4.5 | 7.0 | | 6.0 | 9.0 | ns |
| t_{PHL} | Propagation Delay Time, High-to-Low-Level Output | | | 4.5 | 7.0 | | 6.0 | 9.0 | ns |
| t_{ZL} | Output Enable Time to Low Level | | | 10 | 15 | | 10 | 15 | ns |
| t_{ZH} | Output Enable Time to High Level | | | 6.5 | 10 | | 8.0 | 12 | ns |
| t_{LZ} | Output Disable Time from Low Level | $C_L = 5.0\text{pF}, R_L = 90\Omega$ (Note 3) | | 10 | 15 | | 10 | 25 | ns |
| t_{HZ} | Output Disable Time from High Level | | | 6.0 | 9.0 | | 6.0 | 9.0 | ns |

LOAD CIRCUIT FOR THREE-STATE OUTPUTS

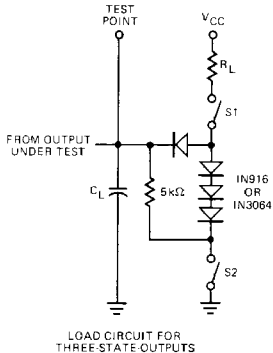

VOLTAGE WAVEFORMS ENABLE AND DISABLE TIMES, THREE-STATE OUTPUTS

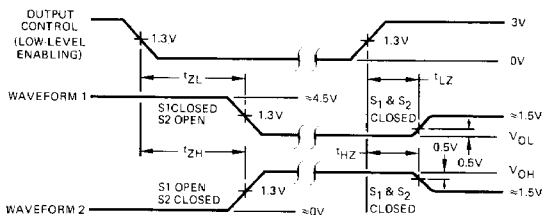

- Notes:
1. Waveform 1 is for an output with internal conditions such that the output is low except when disabled by the output control.
 2. Waveform 2 is for an output with internal conditions such that the output is high except when disabled by the output control.
 3. In the examples above, the phase relationships between inputs and outputs have been chosen arbitrarily. $PRR \leq 1.0\text{MHz}$, $Z_{OUT} \approx 50\Omega$ and $t_r \leq 2.5\text{ns}$, $t_f \leq 2.5\text{ns}$.

FUNCTION TABLES

Am54S/74S242

| CONTROL INPUTS | | DATA OUTPUTS | |
|-----------------|----|----------------|----------------|
| $\overline{1G}$ | 2G | A | B |
| H | H | \overline{O} | I |
| L | H | * | * |
| H | L | ISOLATED | |
| L | L | I | \overline{O} |

I = Input
 O = Output
 \overline{O} = Inverting Output
 H = High
 L = Low

Am54S/74S243

| CONTROL INPUTS | | DATA OUTPUTS | |
|-----------------|----|--------------|---|
| $\overline{1G}$ | 2G | A | B |
| H | H | O | I |
| L | H | * | * |
| H | L | ISOLATED | |
| L | L | I | O |

*Possible destructive oscillation may occur if the transceivers are enabled in both directions at once.

Metallization and Pad Layouts

Am54S/74S242

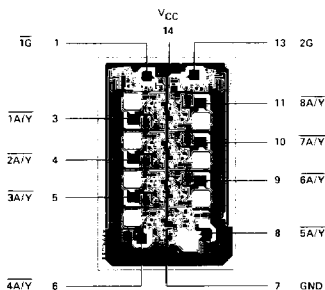

DIE SIZE 0.060" X 0.103"

Am54S/74S243

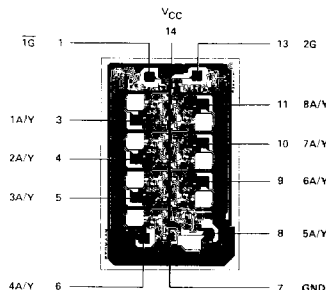

DIE SIZE 0.060" X 0.103"