

FEATURES

- +2.5 Volt Output $\pm 0.10\%$ Max
- Low Temperature Coefficient 25ppm/ $^{\circ}\text{C}$ Max
- Excellent Regulation
 - Load Regulation 20ppm/mA Max
 - Line Regulation 2ppm/V Max
- Supply Current 450 μA Max
- Temperature Voltage Output +1.9mV/ $^{\circ}\text{C}$
- Operating Voltage Range +4.5V to +40V
- Extended Industrial Temp Range -40°C to $+85^{\circ}\text{C}$
- Available in Die Form

PIN CONFIGURATION

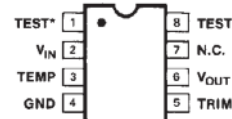

- 8-PIN Cerdip (Z-Suffix)
- 8-PIN Plastic Dip (P-Suffix)
- 8-PIN SO (S-Suffix)

*RESERVED FOR FACTORY TESTING.
MAKE NO ELECTRICAL CONNECTION TO THESE PINS.

GENERAL DESCRIPTION

The REF43 is a low power precision reference providing a stable 2.5 V output independent of variations in supply voltage, load conditions or ambient temperature. It is suitable as a reference level for 8-, 10- and 12-bit data acquisition systems, or wherever a stable, known voltage is required.

Tight output tolerances and low thermal drift are assured by zener-zap trimming of both output voltage and its temperature coefficient. A unique curvature correction circuit reduces the thermal curvature which is characteristic of many previous bandgap references.

ORDERING GUIDE

Model	Initial Accuracy	Temperature Coefficient	Package Description	Package Option	Number of Part per Reel/Tray	Temperature Range
REF43FZ	0.06%	10ppm/ $^{\circ}\text{C}$	8-Pin Hermetic DIP	Q-8	48	-40°C to $+85^{\circ}\text{C}$
REF43GZ	0.10%	25ppm/ $^{\circ}\text{C}$	8-Pin Hermetic DIP	Q-8	48	-40°C to $+85^{\circ}\text{C}$
REF43GP	0.10%	25ppm/ $^{\circ}\text{C}$	8-Pin Plastic DIP	N-8	50	-40°C to $+85^{\circ}\text{C}$
REF43GS	0.10%	25ppm/ $^{\circ}\text{C}$	8-Pin SOIC	R-8	98	-40°C to $+85^{\circ}\text{C}$
REF43GS-REEL	0.10%	25ppm/ $^{\circ}\text{C}$	8-Pin SOIC	R-8	2,500	-40°C to $+85^{\circ}\text{C}$
REF43GS-REEL7	0.10%	25ppm/ $^{\circ}\text{C}$	8-Pin SOIC	R-8	1,000	-40°C to $+85^{\circ}\text{C}$
REF43GSZ*	0.10%	25ppm/ $^{\circ}\text{C}$	8-Pin SOIC	R-8	98	-40°C to $+85^{\circ}\text{C}$
REF43GSZ-REEL7*	0.10%	25ppm/ $^{\circ}\text{C}$	8-Pin SOIC	R-8	1,000	-40°C to $+85^{\circ}\text{C}$
REF43NBC	0.20%		Die		221	

*Z = Pb-free part.

SIMPLIFIED SCHEMATIC

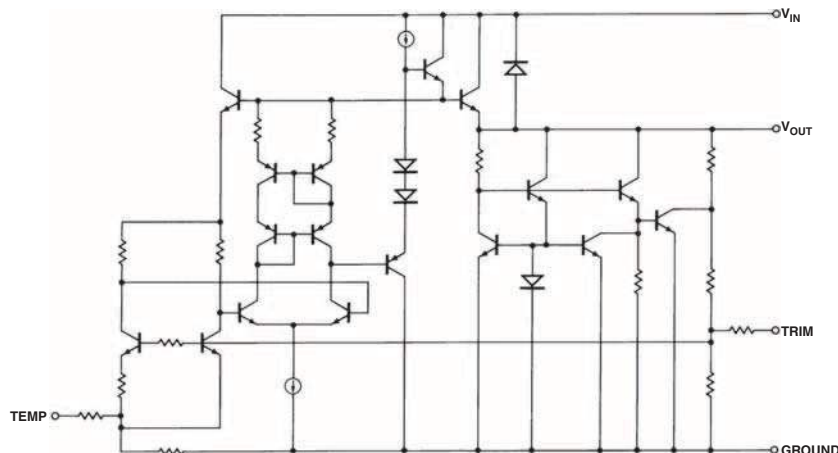

REV. D

Information furnished by Analog Devices is believed to be accurate and reliable. However, no responsibility is assumed by Analog Devices for its use, nor for any infringements of patents or other rights of third parties that may result from its use. No license is granted by implication or otherwise under any patent or patent rights of Analog Devices. Trademarks and registered trademarks are the property of their respective owners.

REF43

The REF-43 may be operated with supply voltages from +4.5V to +40V. The output voltage changes by less than 178 μ V from one extreme of supply voltage to the other. With only 450 μ A maximum quiescent current, the REF-43 is ideally suited to applications where power dissipation must be minimized, as in precision battery-powered equipment. The low supply current minimizes drift due to self-heating after power-up.

A temperature output provides a means of determining system ambient temperature. Applications of the REF-43 include A/D and D/A conversion, 4-20mA transmitter/receiver operation, log amplifiers, and power-supply regulators.

For a low-cost 2.5V reference available in small-outline packages consult the REF-03 data sheet.

ABSOLUTE MAXIMUM RATINGS (Note 1)

Supply Voltage 40V
Output Short-Circuit Duration Indefinite

Operating Temperature Range

REF-43F (J, Z) -40°C to +85°C
REF-43G (J, Z, P, S) -40°C to +85°C
Storage Temperature Range -65°C to +175°C
Junction Temperature Range -65°C to +175°C
Lead Temperature (Soldering, 10 sec) 300°C

PACKAGE TYPE	θ_{JA} (Note 2)	θ_{JC}	UNITS
8-Pin Hermetic DIP (Z)	148	16	°C/W
8-Pin Plastic DIP (P)	103	43	°C/W
8-Pin SO (S)	158	43	°C/W

NOTES:

1. Absolute maximum ratings apply to both DICE and packaged parts, unless otherwise noted.
2. θ_{JA} is specified for worst case mounting conditions, i.e., θ_{JA} is specified for device in socket for TO, CerDIP, P-DIP, and LCC packages; θ_{JA} is specified for device soldered to printed circuit board for SO package.

ELECTRICAL CHARACTERISTICS at $V_{IN} = +5V$, $I_L = 0mA$, $T_A = 25^\circ C$ unless otherwise noted.

PARAMETER	SYMBOL	CONDITIONS	REF-43F			REF-43G			UNITS
			MIN	TYP	MAX	MIN	TYP	MAX	
Output Voltage Tolerance		No Load	—	0.02	0.06	—	0.04	0.1	%
Output Voltage	V_O	No Load	2.4985	2.5000	2.5015	2.4975	2.5000	2.5025	V
Output Voltage Noise	e_{nRMS}	10Hz to 1kHz (Note 1)	—	7	10	—	7	10	μV_{RMS}
Line Regulation		$V_{IN} = +4.5V$ to +40V	—	0.8	2	—	0.8	2	ppm/V
Load Regulation		$I_L = 0mA$ to 10mA	—	14	20	—	14	20	ppm/mA
Quiescent Supply Current	I_{SY}	No Load	—	340	450	—	340	450	μA
Load Current (Sourcing)	I_L	(Note 2)	10	20	—	10	20	—	mA
Load Current (Sinking)	I_S	(Note 3)	—	-1.2	—	—	-1.2	—	mA
Short-Circuit Output Current	I_{SC}	Output Shorted to Ground	—	60	—	—	60	—	mA
Temperature Voltage Output	V_{TEMP}		—	567	—	—	567	—	mV
V_{OUT} Adjust Range			—	± 95	—	—	± 95	—	mV
Long-Term Output Drift	ΔV_O	1,000 Hours	—	40	—	—	40	—	ppm

NOTES:

1. Guaranteed but not tested.
2. Guaranteed by load regulation test.
3. Output remains within 2.5V \pm 2.5mV.

CAUTION

ESD (electrostatic discharge) sensitive device. Electrostatic charges as high as 4000 V readily accumulate on the human body and test equipment and can discharge without detection. Although the REF43 features proprietary ESD protection circuitry, permanent damage may occur on devices subjected to high energy electrostatic discharges. Therefore, proper ESD precautions are recommended to avoid performance degradation or loss of functionality.



ELECTRICAL CHARACTERISTICS at $V_{IN} = +5V$, $I_L = 0mA$, $-40^{\circ}C \leq T_A \leq +85^{\circ}C$ for the REF-43F/G, unless otherwise noted.

PARAMETER	SYMBOL	CONDITIONS	REF-43F			REF-43G			UNITS
			MIN	TYP	MAX	MIN	TYP	MAX	
Output Voltage Tolerance		No Load	-	0.06	0.12	-	0.1	0.2	%
Output Voltage	V_O	No Load	2.497	2.500	2.503	2.495	2.500	2.505	V
Output Voltage Temperature Coefficient	TCV_O	$-55^{\circ}C \leq T_A \leq +125^{\circ}C$ $-40^{\circ}C \leq T_A \leq +85^{\circ}C$ (Note 1)	-	-	-	-	-	-	ppm/ $^{\circ}C$
Line Regulation		$V_{IN} = +4.5V$ to $+40V$	-	1	3	-	1	3	ppm/V
Load Regulation		$I_L = 0mA$ to $10mA$	-	20	35	-	25	40	ppm/mA
Quiescent Supply Current	I_{SY}	No Load	-	400	600	-	400	600	μA
Load Current (Sourcing)	I_L	(Note 2)	10	20	-	10	20	-	mA
Temperature Hysteresis of Output Voltage		$\Delta T = \pm 25^{\circ}C$	-	100	-	-	100	-	μV
Temperature Voltage Output Tempco	TCV_{TEMP}		-	1.9	-	-	1.9	-	mV/ $^{\circ}C$

NOTES:

- Output voltage temperature coefficient is measured by the box method. The tempco is defined as the slope of the diagonal of a box drawn around the output voltage plotted against temperature. V_{OUT} is measured at T_{MIN} , $25^{\circ}C$ and T_{MAX} for the applicable temperature range. The lowest of these three readings is subtracted from the highest reading and the resulting difference is divided by $(T_{MAX} - T_{MIN})$.
- Guaranteed by Load Regulation test.

BURN-IN CIRCUIT

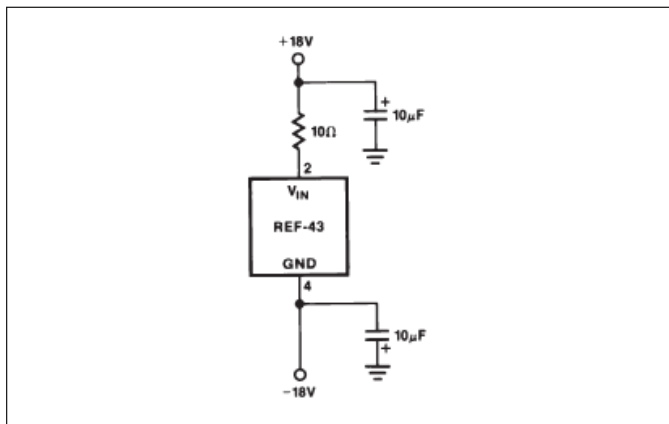

OUTPUT VOLTAGE TRIM METHOD

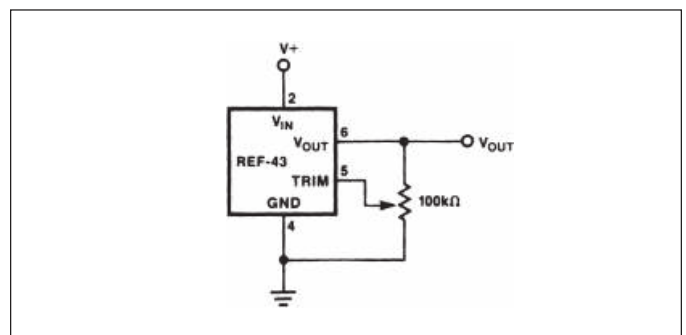

REF43

DICE CHARACTERISTICS

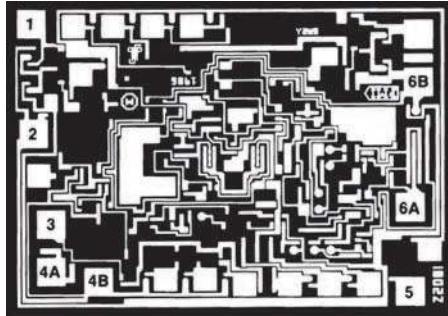

2. VIN
3. TEMPERATURE OUT
- 4A. GROUND*
- 4B. GROUND*
5. TRIM
- 6A. VOUT FO2. VIN
- 6B. VOUT SENSE‡

*PADS 4A AND 4B MUST BOTH BE BONDED TO GROUND.
 ‡VOUT FORCE AND SENSE ARE TYPICALLY BONDED TOGETHER AT THE LOAD.

DIE SIZE 0.085 × 0.062 inch, 5270 sq. mils
 (2.16 × 1.57 mm, 3.39 sq. mm)

WAFER TEST LIMITS at $V_S = +5V$, $T_j = 25^\circ C$, unless otherwise noted.

PARAMETER	SYMBOL	CONDITIONS	REF-43N LIMIT	UNITS
Output Voltage Tolerance		No Load	2.500 ± 0.005	V MAX
		(Note 1)	0.2	% MAX
Line Regulation		$V_{IN} = +4.5V$ to $+40V$	2	ppm MAX
Load Regulation		$I_L = 0mA$ to $10mA$	20	ppm MAX
Quiescent Supply Current	I_{SQ}	No Load	450	μA MAX
Load Current (Sourcing)	I_L	(Note 2)	10	mA MIN

NOTES:

1. Final output trims are not performed on standard product dice. These trims are typically performed after packaging. Precision Monolithics Inc. assumes no responsibility for improper trimming by the customer. Contact factory for trim methods.

2. Guaranteed by load regulation test.

Electrical tests are performed at wafer probe to the limits shown. Due to variations in assembly methods and normal yield loss, yield after packaging is not guaranteed for standard product dice. Consult factory to negotiate specifications based on dice lot qualification through sample lot assembly and testing.

TYPICAL PERFORMANCE CHARACTERISTICS

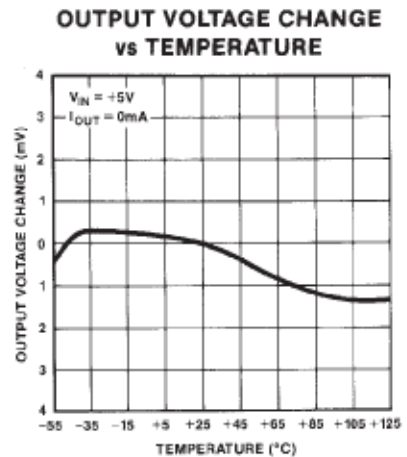
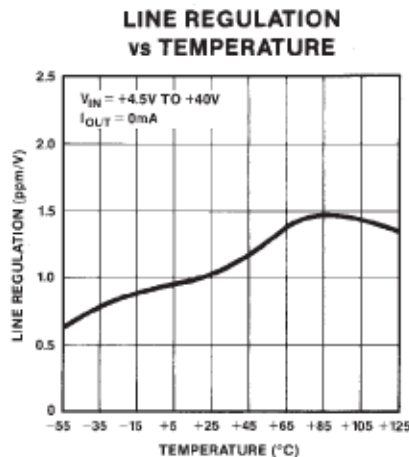
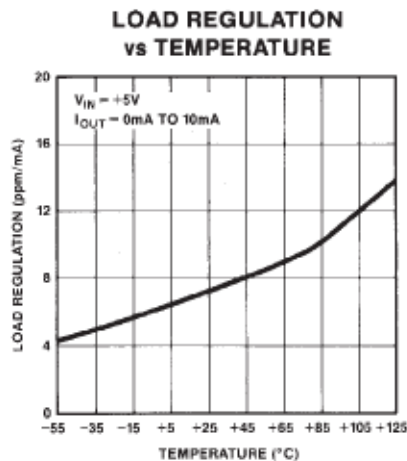

Typical Performance Characteristics—REF43

SUPPLY CURRENT vs TEMPERATURE

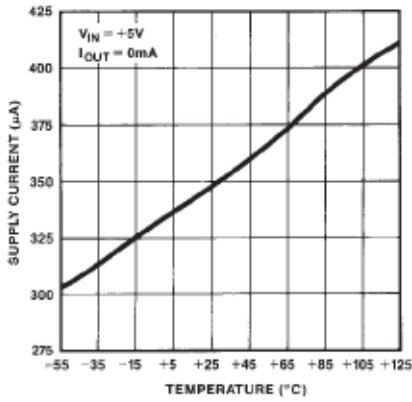

TEMPERATURE PIN VOLTAGE vs TEMPERATURE

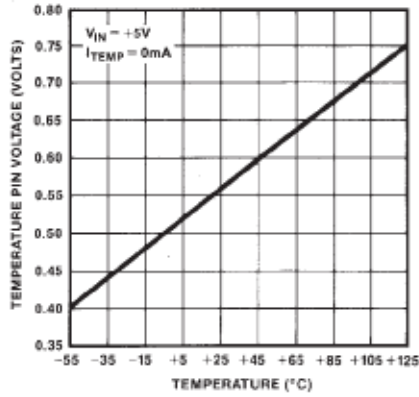

SUPPLY CURRENT vs SUPPLY VOLTAGE

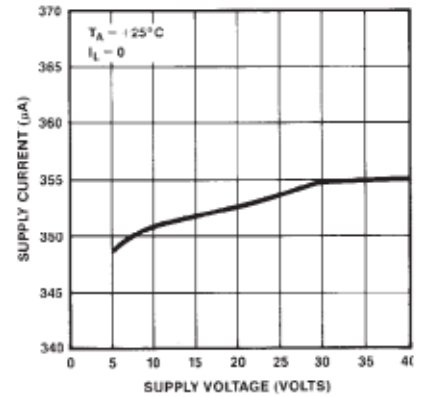

OUTPUT VOLTAGE CHANGE vs SUPPLY VOLTAGE

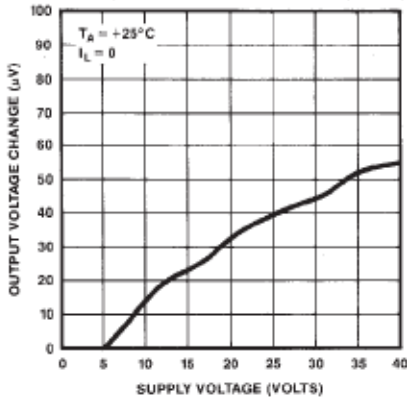

RIPPLE REJECTION vs FREQUENCY

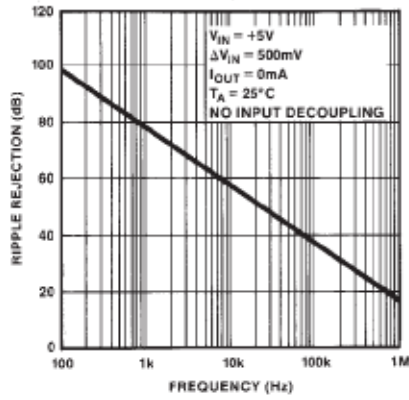

OUTPUT IMPEDANCE vs FREQUENCY

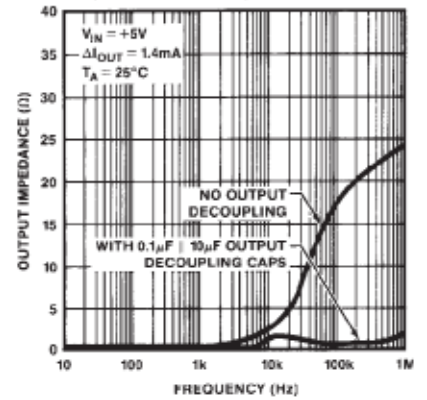

WIDEBAND OUTPUT NOISE vs BANDWIDTH (0.1Hz TO FREQUENCY INDICATED)

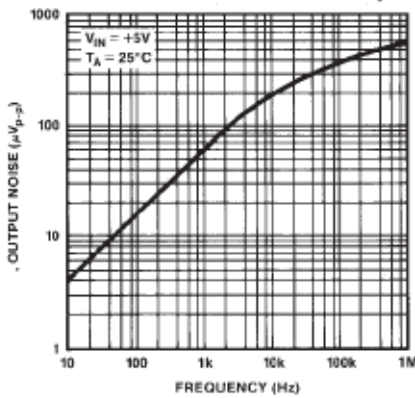

OUTPUT VOLTAGE CHANGE vs LOAD CURRENT

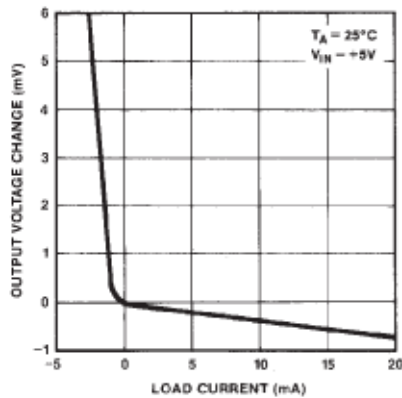

BURN-IN DRIFT AT $T_A = 150^{\circ}\text{C}$

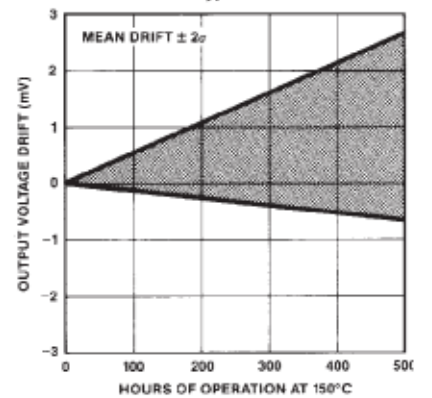

REF43

APPLICATIONS INFORMATION

The REF-43 provides a stable +2.5V output voltage with minimal dependence on load current, line voltage or temperature. This voltage is typically used to set an absolute reference point in data conversion circuits, or in analog circuits such as log amps, 4-20mA transmitters and power supplies. The REF-43 is of particular value in systems requiring a high-precision reference using a single +5V supply rail, or where power dissipation must be minimized.

Because an onboard operational amplifier is used to amplify the basic band gap cell voltage to 2.5V, supply decoupling is critical to the transient performance of a voltage reference. The supply line should be bypassed with a 10µF tantalum capacitor in parallel with a 0.01µF to 0.1µF ceramic capacitor for best results. For less critical conditions, a single 0.1µF capacitor is adequate.

FIGURE 1: Basic Connections

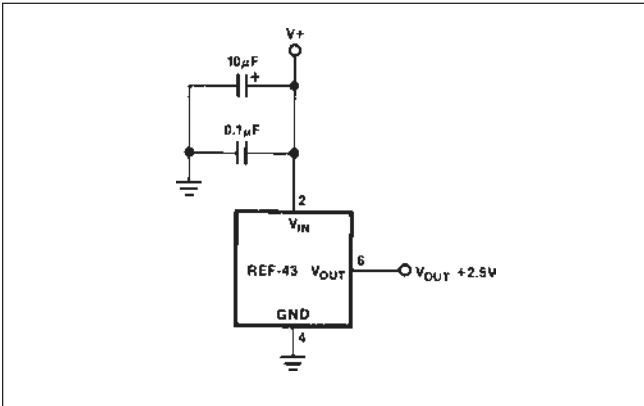

Output decoupling is not generally required or recommended, except to achieve the lowest possible high frequency output impedance when loads are being switched in and out quickly. As was the case with supply decoupling, best results will be achieved with a 10µF tantalum capacitor in parallel with a 0.01µF to 0.1µF ceramic capacitor. Recommended high frequency decoupling is shown in Figure 2A, while the transient response of the REF-43 to a sudden 2mA load is shown in Figures 2B and 2C. As can be seen from Figure 2B, if the reference is given 10µs to settle after application or removal of the load, no output decoupling is necessary.

Load regulation is a measure of the DC output impedance of the reference. For the REF-43, this value is specified at 20ppm/mA Max, which is equivalent to only 50 milliohms of output impedance. It is obvious that to truly realize this performance level, wiring resistances from the reference to the rest of the system must be kept as low as is practical.

The REF-43 is capable of delivering at least 10mA to a load. To maintain its precision operation, loads should be kept within the 10mA specification. High-speed testing requires that load regulation is measured on a pulse basis, therefore

FIGURE 2A: Recommended Decoupling for High Frequency Pulse Response

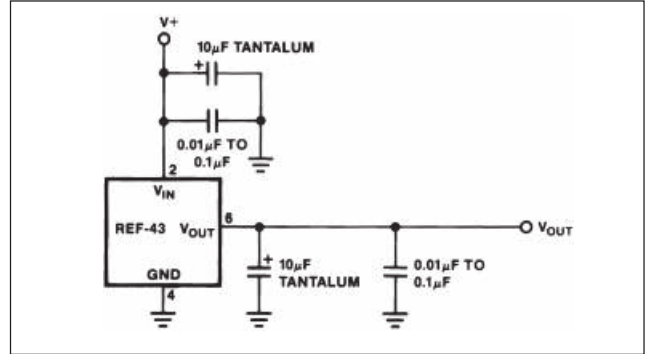

FIGURE 2B: Pulse Response with No Output Decoupling

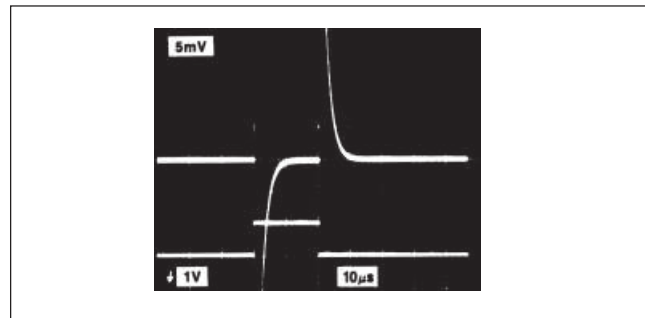
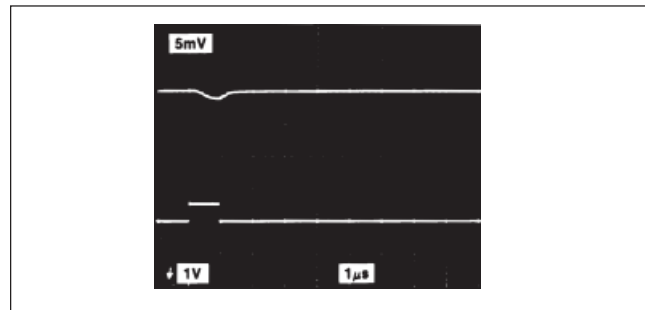

FIGURE 2C: Pulse Response with Output Decoupling



when calculating the output voltage tolerance within a system, the effects of current delivered to the load must be accounted for both as load regulation and as a temperature increase due to power dissipated within the IC. In AC systems, the RMS power dissipation should be used. Thermal effects can be significant since a REF-43 delivering 10mA with an input voltage of 40V must dissipate almost 400mW of power. In the TO-99 package, 400mW of power corresponds to a die temperature increase of 60°C above ambient.

Die temperature is calculated by $T_j = (P_D \times \theta_{JA}) + T_A$, where P_D is the sum of the power dissipation due to quiescent current and current delivered to the load, $P_D = (I_{SY} \times V_S) + (I_{LOAD} \times (V_S - 2.5V))$. The θ_{JA} for different packages in a PC board surrounded by free air are listed below.

PACKAGE TYPE	TYP θ_{JA} (°C/W)
CERDIP	80
PLASTIC	80

An additional source of error is due to temperature gradients across the package leads, resulting in thermocouple effects. Temperature gradients will be generated when the IC is required to dissipate large amounts of power. Even at low power levels, thermocouple effects may appear as low frequency noise due to air currents across the leads. A significant improvement in low frequency noise will be found by encasing the reference and any metal junctions such as solder joints (which form thermocouples) along the reference path in a light insulating foam or other enclosure to reduce turbulence. Thermocouple effects can easily add over $10\mu V_{p-p}$ of low frequency noise.

The temperature output of the REF-43 provides an output voltage which is proportional to the die temperature. When the REF-43 is operating at constant load current, this is a good indication of system temperature. The nominal output voltage at 25°C is 567mV, and the slope is typically $1.9mV/°C$ ($\pm 0.2mV/°C$). The TEMP output is affected by the internal trimming done for output voltage tolerance, and will vary between units. If the Temperature Pin 3 is connected to external circuitry, it should be buffered by an op amp. Current into or out of Pin 3 will change the temperature coefficient and curvature of the output voltage, while capacitance at the pin can create instabilities within the reference amplifier.

GENERATING A -2.5V REFERENCE

Often, there is a requirement for a negative reference voltage. The simplest method of generating a -2.5V reference with the REF-43 is to connect an op amp in a gain of -1 to the output, as shown in Figure 3. This provides both positive and negative 2.5V references. Figure 4 shows another method of obtaining a negative reference, in which the current-output

FIGURE 3: $\pm 2.5V$ Reference

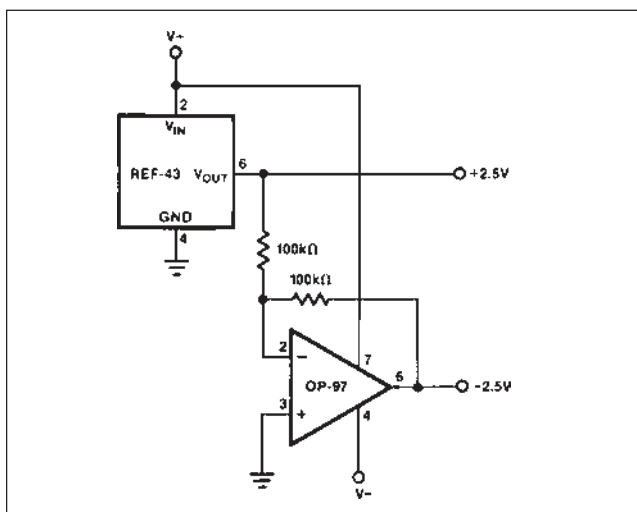
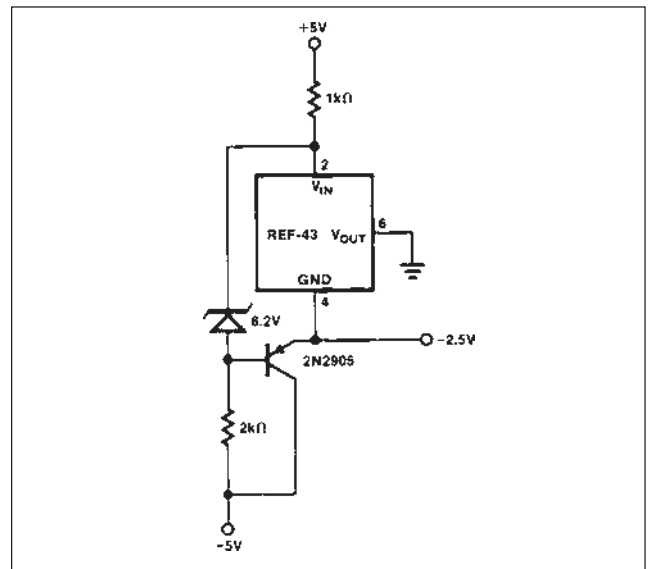

FIGURE 4: -2.5V Reference



element is a PNP transistor, with the REF-43 in a servo loop to ensure that the output remains 2.5V below ground.

BOOST TRANSISTOR PROVIDES HIGH OUTPUT CURRENT

When applications require more than 10mA current delivery, an external boost transistor may be added to the REF-43 to pass the required current without dissipating excessive power within the IC. The maximum current output to the system is bounded only by the capabilities of the boost transistor. This technique is shown in Figure 5 with and without current limiting. Current limiting may be used to prevent damage to the boost transistor. In Figure 5b, the limit occurs when the voltage dropped across R2 exceeds one V_{BE} (0.6V). The current limit is sensitive to the variations of the diodes' forward drop and the PNP's V_{BE} with temperature, and will decrease with increasing temperature.

FIGURE 5: Output Current Boost

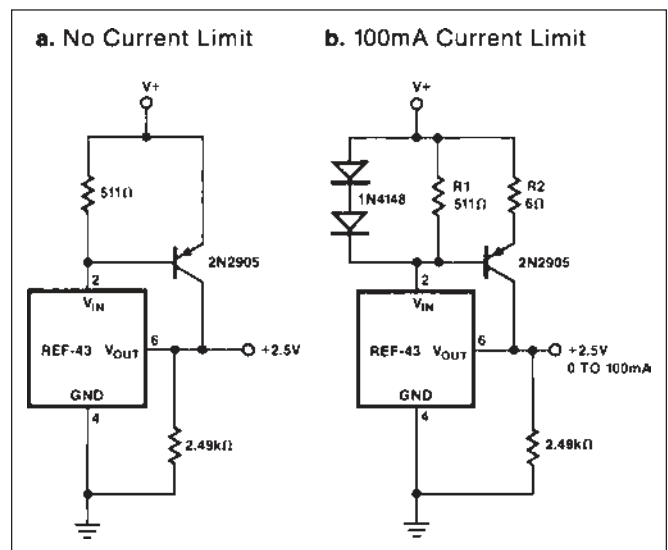

REF43

LOW POWER CMOS DAC REFERENCE

The REF-43 makes an excellent reference for use with CMOS and bipolar DACs. Figure 6 shows the REF-43 connected to the DAC-8012, a 12-bit parallel loading CMOS DAC with memory. With an OP-43 output amplifier for fast settling, the circuit requires less than 3mA when driven from TTL gates, and less than 2mA when driven from CMOS gates. In situations not requiring the higher speed of the OP-43, enhanced linearity and some savings in power dissipation can be realized using an OP-97 for the output amplifier.

PRECISION CURRENT SOURCE

Current sources are often required in analog processing and computational circuits. The circuit of Figure 7 shows a high-output-impedance current source capable of single-supply operation. Performance is optimal at current levels below 1mA, since output voltage changes directly affect the power dissipated within the REF-43.

FIGURE 6: CMOS DAC Reference

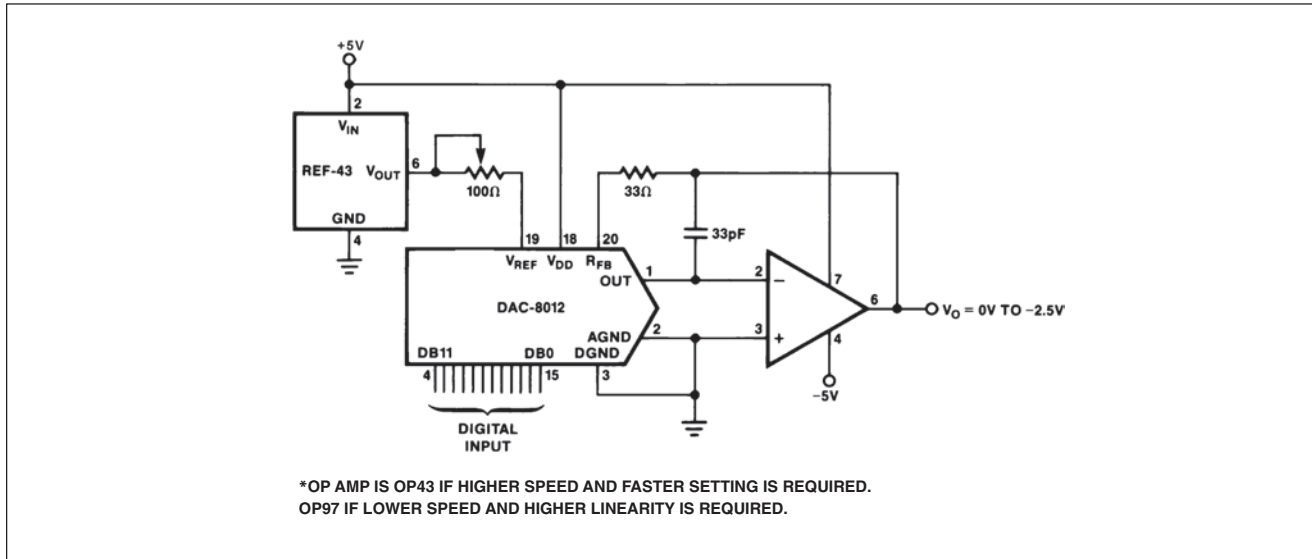

FIGURE 7: Precision Current Source

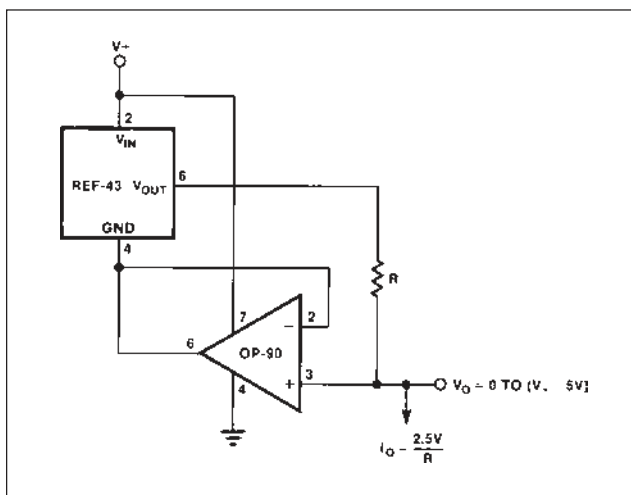

FIGURE 8: Single-Supply Kelvin-Output Thermometer

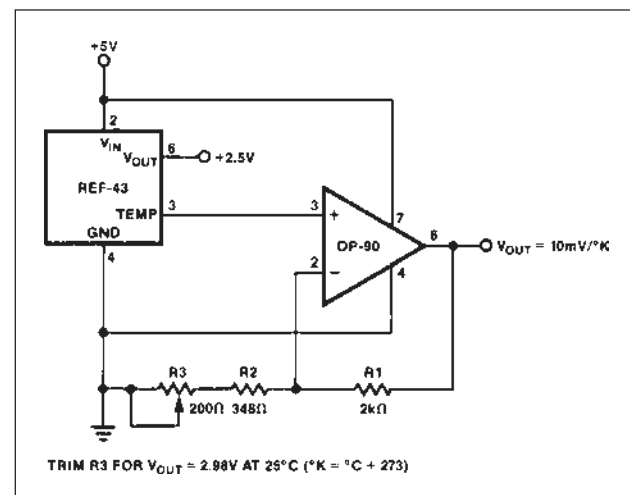
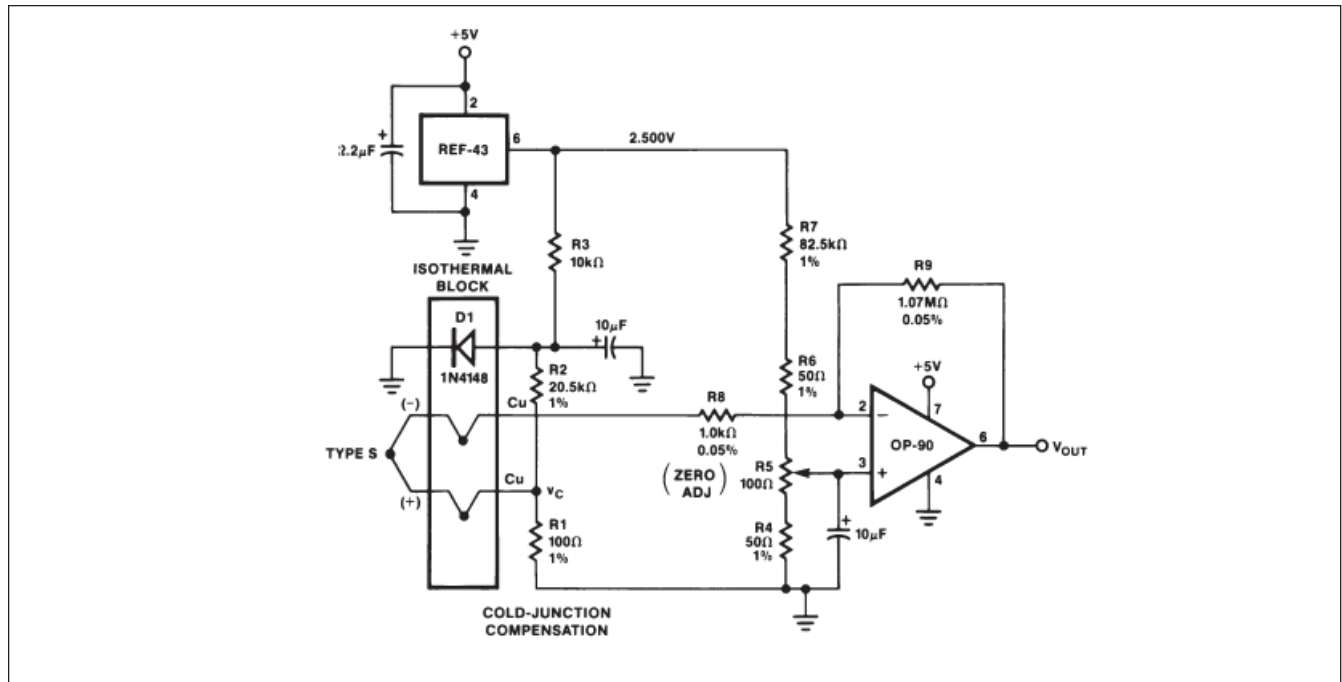

FIGURE 9: Thermocouple Amplifier with Cold-Junction Compensation



TEMPERATURE MEASUREMENT

Using the REF-43's TEMP output, a Kelvin-output thermometer that operates off a single +5V supply can be built as shown in Figure 8. Since the output of the REF-43's TEMP pin is theoretically zero at 0°K, trimming R3 adjusts both the slope and zero point. In actuality, the $\pm 40\text{mV}$ zero point found by extrapolating the TEMP voltage vs. actual temperature to zero will create a small error. A 4-20mA temperature transmitter is described on page 10 which uses two trims to eliminate this inaccuracy.

For wider temperature ranges than semiconductors can withstand, thermocouples are commonly used. Depending upon the type used, a thermocouple can measure temperatures over 1000°C. Thermocouples require a reference junction, at a known temperature, usually 0°C. Since it is not generally convenient to have an ice bath, electronic methods of simulating this junction have been developed, called cold-junction compensation. In Figure 9, diode D1 is mounted isothermally to the termination of the thermocouple, and along with R1 and R2 provides the cold-junction compensation required for accurate measurement. Using an OP-90 as the amplifier, the circuit will operate off a single +5V supply and is capable of measuring temperatures from 0°C to +400°C. If negative temperatures must be measured, dual supplies must be used to allow the op amp to swing negative. In cases where the electronics are subject to temperature fluctuations, an OP-77 is recommended for its extremely low TCV_{OS} .

Calibration of the thermocouple amplifier is done after a 15 minute warm-up time using R5. A copper wire short is placed across the thermocouple terminating junctions, simulating a 0°C condition. R5 is then adjusted for a 0.00V output. The short is then removed and the amplifier is ready for use. Note that special care must be used in calibration when this circuit is operated single-supply, as the output of the OP-90 will swing to within 500µV of ground, but not below ground. Thus R5 must be trimmed to the point where the output just barely reaches its swing limit.

By changing the appropriate resistor values, the amplifier may be used with type S, J or K thermocouples. In all cases, the output has been scaled with R9 to provide an output of 10mV/°C.

SEEBECK					
TYPE	COEFFICIENT, α	R1	R2	R7	R9
K	39.2µV/°C	110Ω	5.76kΩ	102kΩ	269kΩ
J	50.2µV/°C	100Ω	4.02kΩ	80.6kΩ	200kΩ
S	10.3µV/°C	100Ω	20.5kΩ	392kΩ	1.07MΩ

TWO-WIRE 4-20mA TRANSMITTERS

4-20mA current loops are used in noisy environments for many types of remote data acquisition. With a two-wire loop, the sensing circuitry can be powered with the same lines used for signal transmission.

REF43

FIGURE 10: Two Wire 4-20mA Transmitter

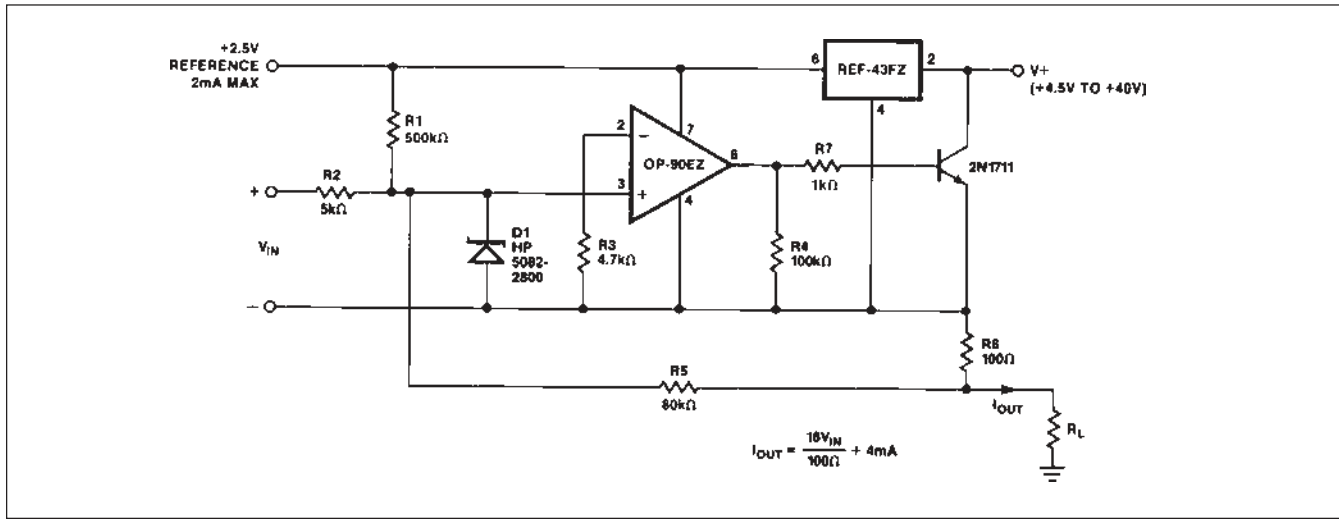

The current transmitter of Figure 10 provides an output of 4mA to 20mA that is linearly proportional to the input voltage. Linearity of the transmitter exceeds 0.004% and line rejection is below measurement limits.

Biasing for the current transmitter is provided by the REF-43FZ. The OP-90EZ regulates the output current to satisfy the current summation at the noninverting node:

$$I_{OUT} = \frac{1}{R_6} \left(\frac{V_{IN} R_5}{R_2} + \frac{2.5V R_5}{R_1} \right)$$

For the values shown in Figure 10,

$$I_{OUT} = \left(\frac{16}{100\Omega} \right) V_{IN} + 4mA$$

giving a full-scale output of 20mA with a 100mV input. Adjustment of R2 will provide an offset trim and adjustment of R1 will provide a gain trim. These trims do not interact since the noninverting input of the OP-90 is at virtual ground. The Schottky diode, D1, prevents input voltage spikes from pulling the noninverting input more than 300mV below the inverting input. Without the diode, such spikes could cause phase reversal of the OP-90 and possible latch-up of the transmitter. Compliance of this circuit is from 4.5V to 40V. The voltage reference output can provide up to 2mA for transducer excitation.

The OP-90 is also available in dual and quad versions. Using an OP-490, three of the amplifiers can be used to implement a full instrumentation amplifier for signal conditioning before delivery to the 4-20mA transmitter. All four OP-90s require less than 80μA supply current, and thus have virtually no impact on the current-budget of the 4-20mA loop.

A simple temperature to 4-20mA transmitter is shown in Figure 11. After calibration, the transmitter is accurate to within 1°C over the -50°C to +150°C temperature range. The transmitter operates from +6V to +40V with supply rejection better than

3ppm/V. An OP-90 is used to buffer the TEMP pin, while the second OP-90 regulates the output current to satisfy the current summation at its noninverting input.

$$I_{OUT} = \frac{V_{TEMP} (R_6 + R_7)}{R_2 R_{10}} - V_{SET} \left(\frac{R_2 + R_6 + R_7}{R_2 R_{10}} \right)$$

The change in output current with temperature is the derivative of the transfer function:

$$\frac{\Delta I_{OUT}}{\Delta T} = \frac{\Delta V_{TEMP}}{\Delta T} \left(\frac{R_6 + R_7}{R_2 R_{10}} \right)$$

From the formulas, it can be seen that if the gain trim is adjusted before the final offset trim, the two trims are not interactive, which greatly simplifies the calibration procedure.

To calibrate the transmitter, begin by placing the REF-43 in an ice water (0°C) bath. If necessary, adjust the offset trim, R5, so that the output current is above 4mA.

Record the output current. Next, place the REF-02 in a boiling water (100°C) bath. Adjust the gain trim, R6, so that the change in the output current reflects the desired mA/°C ratio described as follows:

$$\text{Output Ratio} = \frac{\Delta I_{FS}}{\Delta T_{OPERATING}} = \frac{16mA}{\Delta T_{OPERATING}}$$

As an example, assume the transmitter is to operate over the -50°C to +150°C temperature range:

$$\text{Output Ratio} = \frac{16mA}{(150^\circ C - 50^\circ C)} = \frac{16mA}{(200^\circ C)} = 0.08mA/^\circ C$$

If I_{OUT} in the ice water bath equaled 6.3mA, then in the boiling water bath:

$$I_{OUT(100^\circ C)} = I_{OUT(0^\circ C)} + 100^\circ C (0.08mA/^\circ C) \\ = 6.3mA + 8mA = 14.3mA$$

With the REF-43 in the boiling water bath, the gain trim, R6, in this example should be adjusted so I_{OUT} equals 14.3mA.

Once the gain trim has been completed, the offset trim can be made. Remember, that adjusting the offset trim will not affect the gain.

The offset trim can be set at any known temperature by adjusting R5 until the output current equals:

$$I_{OUT} = \left(\frac{\Delta I_{FS}}{\Delta T_{OPERATING}} \right) (T_{AMBIENT} - T_{MIN}) + 4mA$$

Using the previous example and assuming the REF-43 is at 20°C:

$$I_{OUT} = \left(\frac{16mA}{200°C} \right) [20°C - (-50°C)] + 4mA = 9.6mA$$

Table 1 shows the values of R6 and R7 required for various temperature ranges.

TABLE 1

TEMP RANGE	R6 (FIXED)	R7 (TRIMPOT)
0°C to +70°C	10k	5k
-40°C to +85°C	6k	3k
-50°C to +150°C	3k	2k

FIGURE 11: Temperature to 4-20mA Transmitter

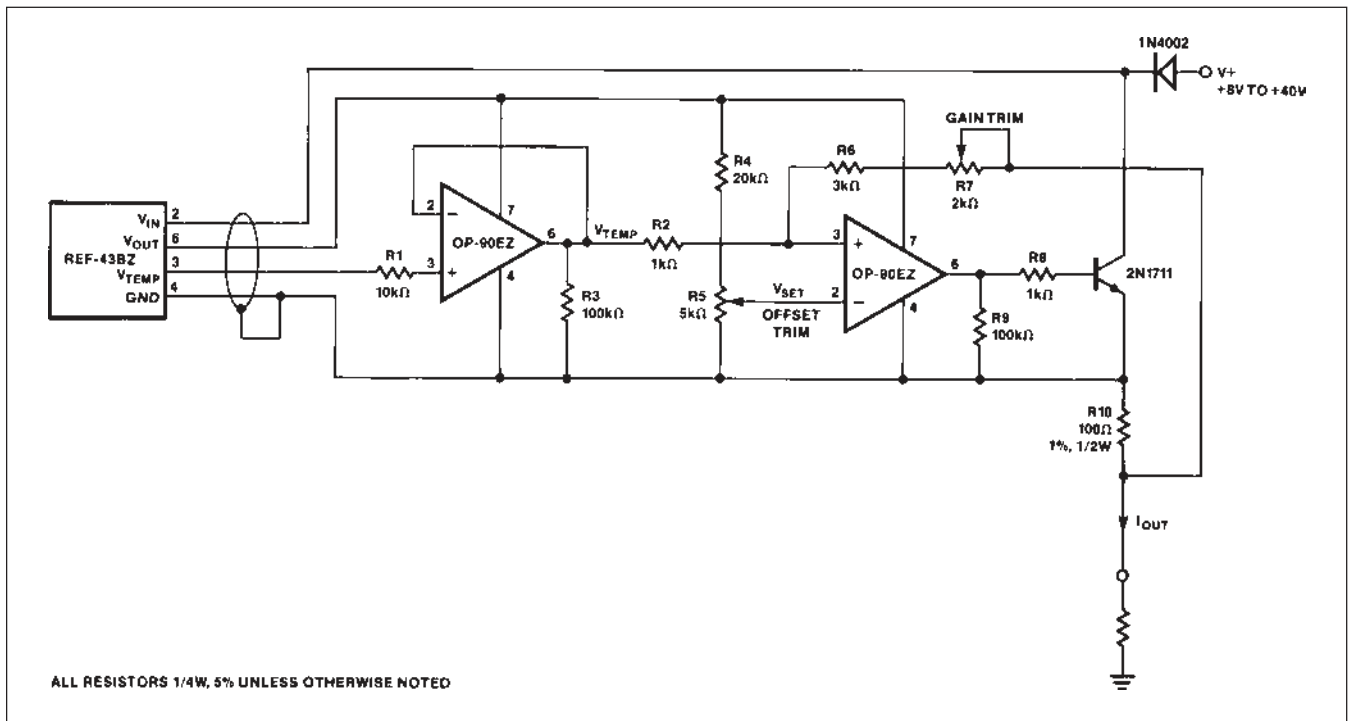
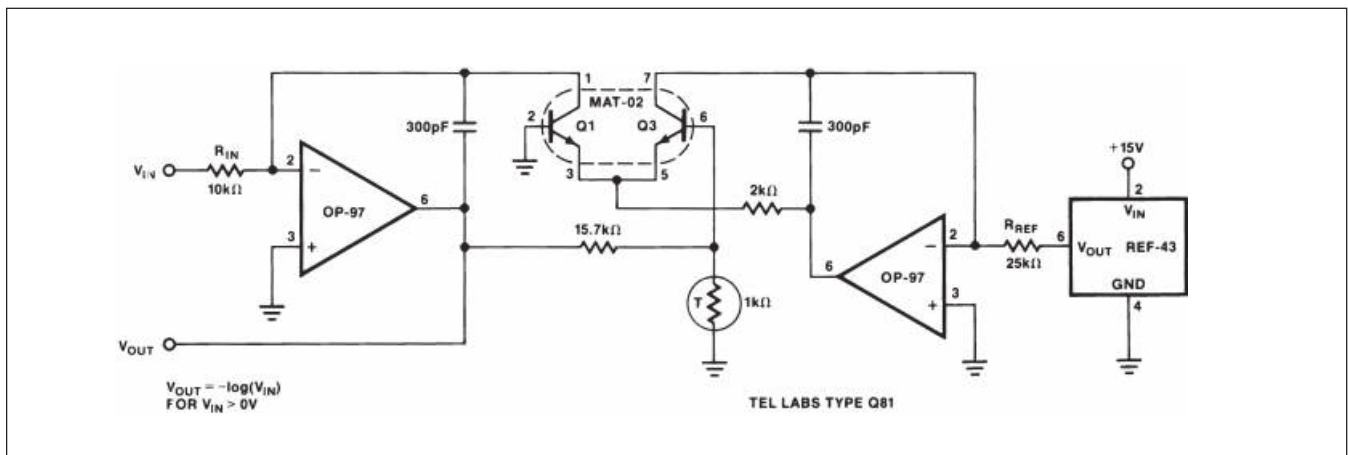

FIGURE 12: Low Power Logarithmic Amplifier



LOW-POWER LOGARITHMIC AMPLIFIER

A logarithmic amplifier accurate over more than 4 decades is shown in Figure 12. This circuit requires less than 2mA of current when the input is at 1V (0V output). The output

voltage is given by $V_{OUT} = \log(V_{REF}/R_{REF}) - \log(V_{IN}/R_{IN})$, thus the zero point may be adjusted by R_{REF} and the input scaling by R_{IN}.

OUTLINE DIMENSIONS

8-Lead Ceramic Dual In-Line Package [CERDIP]
(Q-8)
Z-Suffix

Dimensions shown in inches and (millimeters)

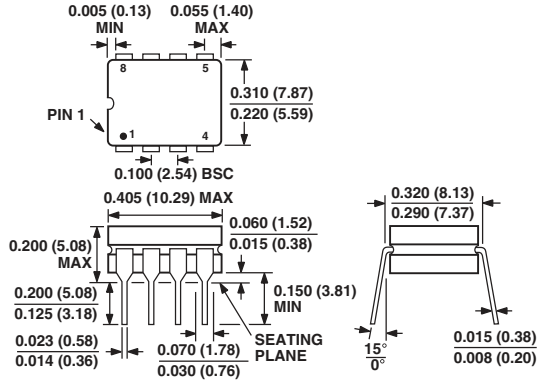

CONTROLLING DIMENSIONS ARE IN INCHES; MILLIMETER DIMENSIONS (IN PARENTHESES) ARE ROUNDED-OFF INCH EQUIVALENTS FOR REFERENCE ONLY AND ARE NOT APPROPRIATE FOR USE IN DESIGN

8-Lead Standard Small Outline Package [SOIC]
(R-8)
S-Suffix

Dimensions shown in millimeters and (inches)

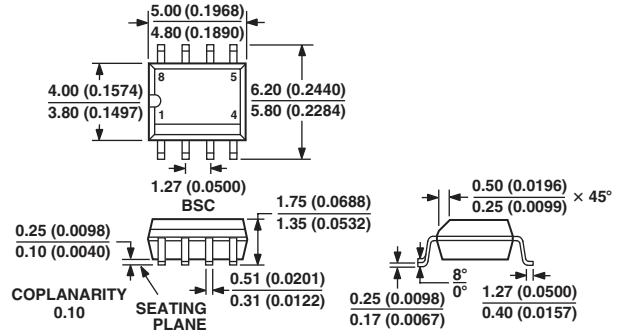

COMPLIANT TO JEDEC STANDARDS MS-012AA
CONTROLLING DIMENSIONS ARE IN MILLIMETERS; INCH DIMENSIONS (IN PARENTHESES) ARE ROUNDED-OFF MILLIMETER EQUIVALENTS FOR REFERENCE ONLY AND ARE NOT APPROPRIATE FOR USE IN DESIGN

8-Lead Plastic Dual In-Line Package [PDIP]
(N-8)
P-Suffix

Dimensions shown in inches and (millimeters)

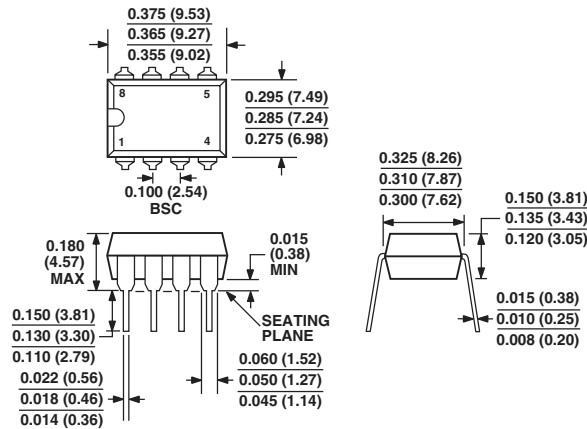

COMPLIANT TO JEDEC STANDARDS MO-095AA
CONTROLLING DIMENSIONS ARE IN INCHES; MILLIMETER DIMENSIONS (IN PARENTHESES) ARE ROUNDED-OFF INCH EQUIVALENTS FOR REFERENCE ONLY AND ARE NOT APPROPRIATE FOR USE IN DESIGN

Revision History

Location	Page
8/04—Data Sheet Changed from REV. C to REV. D.	
Edits to FEATURES	1
Changes to PIN CONFIGURATION	1
Changes to ORDERING GUIDE	1
Changes to ABSOLUTE MAXIMUM RATINGS	2
Changes to PACKAGE TYPE	2
Changes to ELECTRICAL CHARACTERISTICS	2
Deleted PACKAGE TYPE	7