

MDE Semiconductor, Inc.

201 Shipyard Way, Unit C, Newport Beach, CA., USA 92663 Tel : 760-564-8656 • Fax : 760-564-2414
1-800-831-4881 Email: sales@mdesemiconductor.com Web: www.mdesemiconductor.com

MP6KE SERIES

GLASS PASSIVATED JUNCTION TRANSIENT VOLTAGE SUPPRESSOR

VOLTAGE - 6.8 TO 550 Volts
600 Watt Peak Power 5.0 Watt Steady State

FEATURES

- Plastic package has Underwriters Laboratory Flammability Classification 94 V-0
- Glass passivated chip junction in DO-15 (DO-204AC) package
- 600W surge capability at 10/1000 μ s
- Low zenen impedance
- Excellent clamping capability
- Fast response time: typically less than 1.0 ps from 0 volts to BV min.
- Typical IR less than 1 μ A above 10V
- High temperature soldering guaranteed: 265°C/10 seconds/ .375", (9.5mm) lead length, 5lbs., (2.3kg) tension

MECHANICAL DATA

Case: JEDEC DO-15 Molded plastic
Terminals: Plated Axial leads, solderable per MIL-STD-750, Method 2026
Polarity: Color band denoted positive end (cathode) except Bipolar
Mounting Position: Any
Weight: 0.015 ounces, 0.4 grams

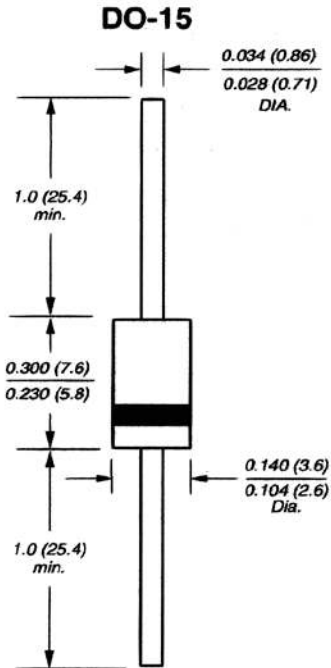

Dimensions in inches and (millimeters)

DEVICES FOR BIPOLAR APPLICATIONS

For Bidirectional use C or CA Suffix for types P6KE6.80 thru types P6KE550 (e.g. P6KE6.8C, P6KE550CA)
Electrical characteristics apply in both directions.

MAXIMUM RATINGS AND CHARACTERISTICS

Ratings at 25°C ambient temperature unless otherwise specified.

RATING	SYMBOL	VALUE	UNITS
Peak Pulse Power Dissipation at TA = 25 °C, TP = 1ms (NOTE 1)	P _{PPM}	Minimum 600	Watts
Peak Pulse Current of on 10/1000 μ s waveform (Note 1)	I _{PPM}	SEE TABLE 1	Amps
Steady State Power Dissipation at TL = 75°C Lead lengths .375", 9.5mm (Note 2)	P _{M(AV)}	1.0	Watts
Peak Forward Surge Current, 8.3ms Single Half Sine-wave Superimposed on Rated Load, (JEDEC Method)(Note 3)	I _{FSM}	100	Amps
Operatings and Storage Temperature Range	T _J , T _{STG}	-55 +175	°C

NOTES:

1. Non-repetitive current pulse, per Fig.3 and derated above Ta=25 °C per Fig.2.
2. Mounted on Copper Pad area of 1.6x1.6" (40x40mm) per Fig.5.
3. 8.3ms single half sine-wave, or equivalent square wave, Duty cycle=4 pulses per minutes maximum.

Certified RoHS Compliant

UL File # E223026

2/10/2022

MDE Semiconductor, Inc.

201 Shipyard Way, Unit C, Newport Beach, CA., USA 92663 Tel : 760-564-8656 • Fax : 760-564-2414
 1-800-831-4881 Email: sales@mdesemiconductor.com Web: www.mdesemiconductor.com

RATING AND CHARACTERISTIC CURVES MP6KE SERIES

Fig.1 - Peak Pulse Power Rating Curve

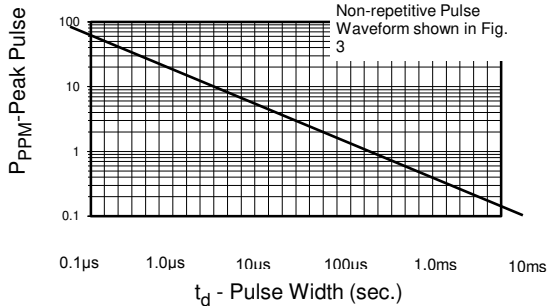

Fig.2 - Pulse Derating Curve

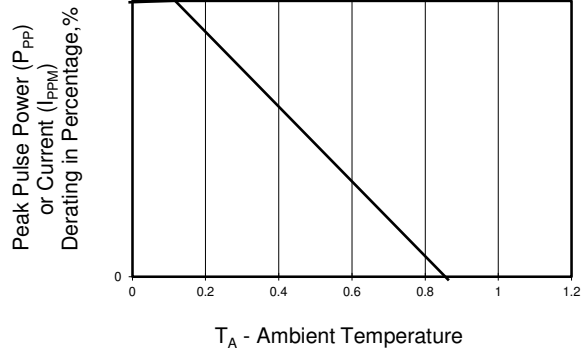

Fig.3 - Pulse Waveform

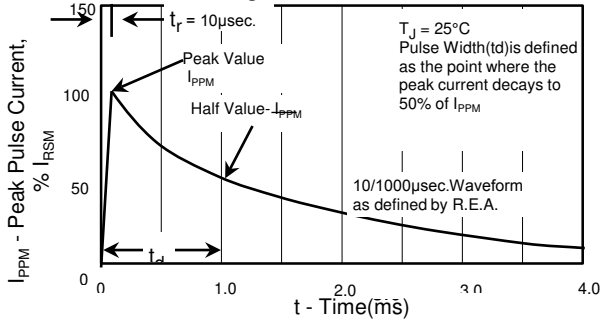

Fig.4 - Typ. Junction Capacitance Uni-

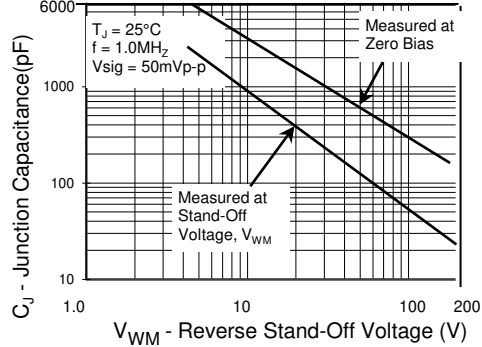

Fig.5 - steady State Power Derating Curve

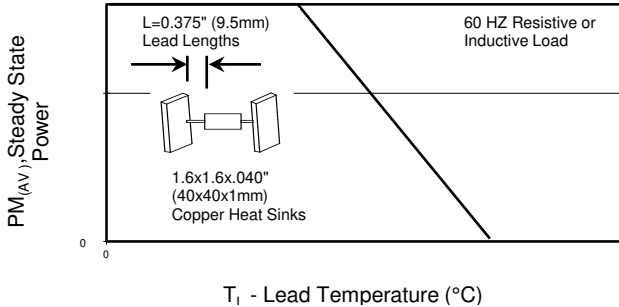

Fig.6 - Max. Non-Repetitive Forward Surge

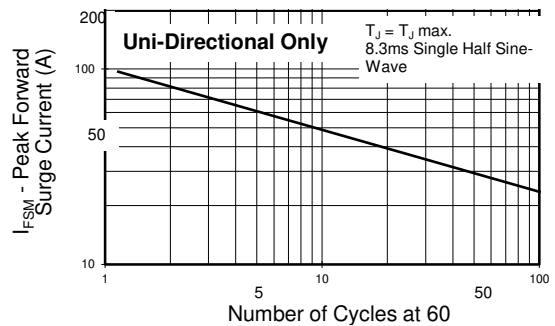

Fig.7 - Typical Reverse Leakage Characteristics

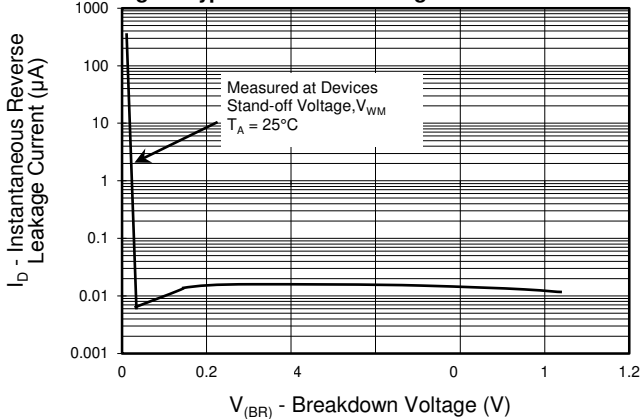
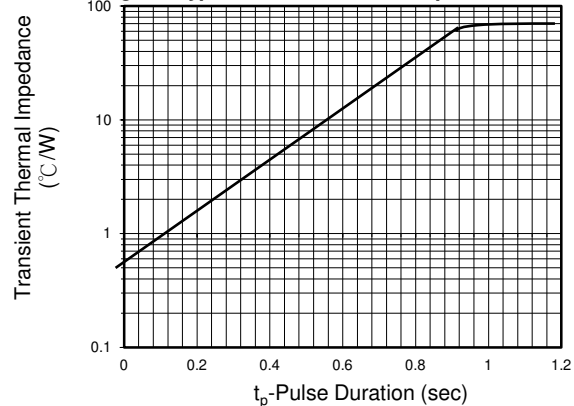

Fig.8 - Typ. Transient Thermal Impedance



MDE Semiconductor, Inc.

201 Shipyard Way, Unit C, Newport Beach, CA., USA 92663 Tel : 760-564-8656 • Fax : 760-564-2414
1-800-831-4881 Email: sales@mdesemiconductor.com Web: www.mdesemiconductor.com

600 Watt TVS

UNI-POLAR	BI-POLAR	REVERSE STANDOFF VOLTAGE V _{RWM} (V)	BREAKDOWN VOLTAGE V _{BR} (V) MIN. @ I _T	BREAKDOWN VOLTAGE V _{BR} (V) MAX. @ I _T	TEST CURRENT (I _T) mA	MAXIMUM CLAMPING VOLTAGE @I _{PP} V _C (V)	PEAK PULSE CURRENT I _{PP} (A)	REVERSE LEAKAGE @ V _{RWM} I _R (μA)
MP6KE6.8A	MP6KE6.8CA	5.80	6.45	7.14	10	10.5	58.1	1000
MP6KE7.5A	MP6KE7.5CA	6.40	7.13	7.88	10	11.3	54.0	500
MP6KE8.2A	MP6KE8.2CA	7.02	7.79	8.61	10	12.1	50.4	200
MP6KE9.1A	MP6KE9.1CA	7.78	8.65	9.55	10	13.4	45.5	50
MP6KE10A	MP6KE10CA	8.55	9.50	10.50	1	14.5	42.1	10
MP6KE11A	MP6KE11CA	9.40	10.50	11.60	1	15.6	39.1	5
MP6KE12A	MP6KE12CA	10.20	11.40	12.60	1	16.7	36.5	5
MP6KE13A	MP6KE13CA	11.10	12.40	13.70	1	18.2	33.5	5
MP6KE15A	MP6KE15CA	10.00	14.30	15.80	1	21.2	28.8	5
MP6KE16A	MP6KE16CA	12.90	15.20	16.80	1	22.5	27.1	5
MP6KE18A	MP6KE18CA	14.50	17.10	18.90	1	25.2	24.2	5
MP6KE20A	MP6KE20CA	17.10	19.00	21.00	1	27.7	22.0	5
MP6KE22A	MP6KE22CA	18.80	20.90	23.10	1	30.6	19.9	5
MP6KE24A	MP6KE24CA	20.50	22.80	25.20	1	33.2	18.4	5
MP6KE27A	MP6KE27CA	23.10	25.70	28.40	1	37.5	16.3	5
MP6KE30A	MP6KE30CA	25.60	28.50	31.50	1	41.4	14.7	5
MP6KE33A	MP6KE33CA	28.20	31.40	34.70	1	45.7	13.3	5
MP6KE36A	MP6KE36CA	30.80	34.20	37.80	1	49.9	12.2	5
MP6KE39A	MP6KE39CA	33.30	37.10	41.00	1	53.9	11.3	5
MP6KE43A	MP6KE43CA	36.80	40.90	45.20	1	59.3	10.3	5
MP6KE47A	MP6KE47CA	40.20	44.70	49.40	1	64.8	9.4	5
MP6KE51A	MP6KE51CA	43.60	48.50	53.60	1	70.1	8.7	5
MP6KE56A	MP6KE56CA	47.80	53.20	58.80	1	77.0	7.9	5
MP6KE62A	MP6KE62CA	53.00	58.90	65.10	1	85.0	7.2	5
MP6KE68A	MP6KE68CA	58.10	64.60	71.40	1	92.0	6.6	5
MP6KE75A	MP6KE75CA	64.10	71.30	78.80	1	103.0	5.9	5
MP6KE82A	MP6KE82CA	70.10	77.90	86.10	1	113.0	5.4	5
MP6KE91A	MP6KE91CA	77.80	86.50	95.50	1	125.0	4.9	5
MP6KE100A	MP6KE100CA	85.50	95.00	105.00	1	137.0	4.5	5
MP6KE110A	MP6KE110CA	94.00	105.00	116.00	1	152.0	4.0	5
MP6KE120A	MP6KE120CA	102.00	114.00	126.00	1	165.0	3.7	5
MP6KE130A	MP6KE130CA	111.00	124.00	137.00	1	179.0	3.4	5
MP6KE150A	MP6KE150CA	128.00	143.00	158.00	1	207.0	2.9	5
MP6KE160A	MP6KE160CA	136.00	152.00	168.00	1	219.0	2.8	5
MP6KE170A	MP6KE170CA	145.00	162.00	179.00	1	234.0	2.6	5
MP6KE180A	MP6KE180CA	154.00	171.00	189.00	1	246.0	2.5	5
MP6KE200A	MP6KE200CA	171.00	190.00	210.00	1	274.0	2.2	5
MP6KE220A	MP6KE220CA	185.00	209.00	231.00	1	328.0	1.9	5
MP6KE250A	MP6KE250CA	214.00	237.00	263.00	1	344.0	1.8	5
MP6KE300A	MP6KE300CA	256.00	285.00	315.00	1	414.0	1.5	5
MP6KE350A	MP6KE350CA	300.00	333.00	368.00	1	482.0	1.3	5
MP6KE400A	MP6KE400CA	342.00	380.00	420.00	1	548.0	1.1	5
MP6KE440A	MP6KE440CA	376.00	418.00	462.00	1	602.0	1.0	5
MP6KE480A	MP6KE480CA	408.00	456.00	504.00	1	658.0	0.9	5
MP6KE510A	MP6KE510CA	434.00	485.00	535.00	1	698.0	0.9	5
MP6KE530A	MP6KE530CA	450.00	503.50	556.50	1	725.0	0.8	5
MP6KE540A	MP6KE540CA	459.00	513.00	567.00	1	740.0	0.8	5
MP6KE550A	MP6KE550CA	467.00	522.50	577.50	1	760.0	0.8	5

For bidirectional type having V_{rwm} of 10 volts and less, the I_R limit is double.

For parts without A , the V_{BR} is ± 10%

Certified RoHS Compliant
UL File # E223026