

## ±80V Fault-Protected/Tolerant CAN Transceiver

## MAX3054/MAX3055/ MAX3056

### General Description

The MAX3054/MAX3055/MAX3056 are interfaces between the protocol controller and the physical wires of the bus lines in a controller area network (CAN). The devices provide differential transmit capability and switch to single-mode if certain fault conditions occur. The MAX3054/MAX3055/MAX3056 guarantee full wakeup capability during failure modes.

The extended fault-protected voltage range of CANH and CANL bus lines of ±80V. Current-limiting and thermal-protection circuits protect the transmitter output stage against overcurrent faults to prevent destruction of the transmitter output stage. The CANH and CANL lines are also protected against electrical transients that may occur in rugged environments.

The transceiver provides three low-power modes that can be entered and exited through pins  $\overline{\text{STB}}$  and EN. An output INH pin can be used for deactivation of an external voltage regulator.

The MAX3054/MAX3055/MAX3056 are designed to provide optimal operation for a specified data rate. The MAX3054 is ideal for high data rates of 250kbps. The MAX3055 is used for data rates of 125kbps and the MAX3056 is designed for 40kbps applications. For 40kbps and 125kbps versions, a built-in slope-control feature allows the use of unshielded cables, and receiver input filters guarantee high noise immunity.

### Applications

- Industrial HVAC

### Typical Operating Circuit

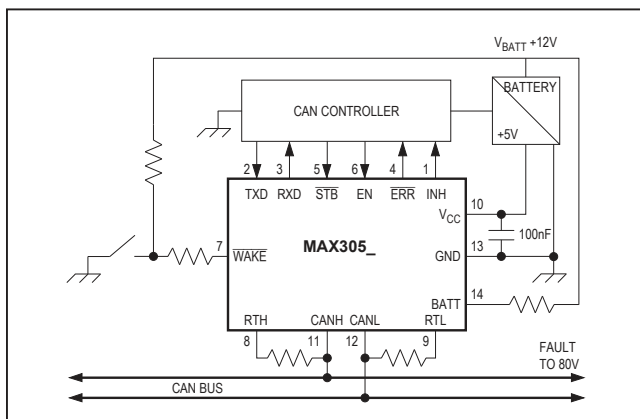

### Features

- ±80V Fault Protection
- Low RFI/Excellent EMC Immunity
- Full Wake-Up Capability During Failure Modes
- Bus Failure Management
- Support Single-Wire Transmission Mode with Ground Offset Voltages Up to 1.5V
- Thermally Protected
- Do Not Disturb the Bus Line when Unpowered
- Low-Current Sleep and Standby Mode with Wake-Up Through Bus Lines
- Up to 250kbps Data Rate (MAX3054)
- Pin and Functionally Compatible with TJA1054

### Ordering Information

PART	TEMP RANGE	DATA RATE	PIN-PACKAGE
MAX3054ASD+	-40°C to +125°C	250kbps	14 SO
MAX3055ASD+	-40°C to +125°C	Slew control 125kbps	14 SO
MAX3056ASD+	-40°C to +125°C	Slew control 40kbps	14 SO

+Lead-free/RoHS-compliant package

### Pin Configuration

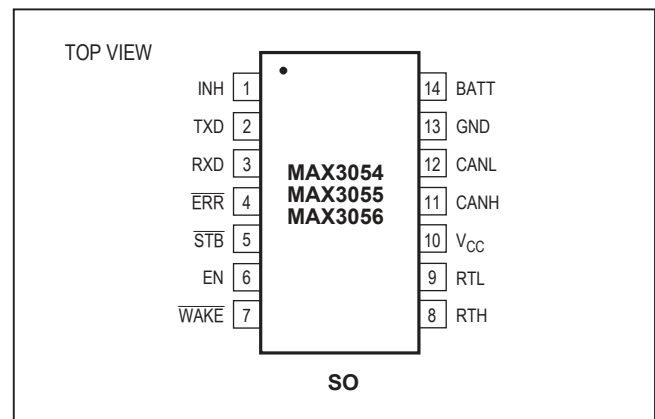

19-2687; Rev 2; 2/21

**Absolute Maximum Ratings**

(All Voltages are Referenced to GND)

Supply Voltage ( $V_{CC}$ )	-0.3V to +6V
Battery Voltage ( $V_{BATT}$ )	-0.3V to +80V
TXD, RXD, $\overline{ERR}$ , STB, EN	-0.3V to ( $V_{CC} + 0.3V$ )
CANH, CANL	-80V to +80V
RTH, RTL	-0.3V to +80V
RTH, RTL Current	±180mA
WAKE	-0.3V to +80V
INH	-0.3V to ( $V_{BATT} + 0.3V$ )

INH Current	-0.5mA
Transient Voltage (ISO 7637)	-200V, +200V
Continuous Power Dissipation ( $T_A = +70^\circ\text{C}$ )	
14-Pin SO (derate 8.3mW/°C above +70°C)	667mW
Operating Temperature Range	-40°C to +125°C
Junction Temperature	+150°C
Storage Temperature Range	-65°C to +150°C
Lead Temperature (soldering, 10s)	+300°C

Stresses beyond those listed under "Absolute Maximum Ratings" may cause permanent damage to the device. These are stress ratings only, and functional operation of the device at these or any other conditions beyond those indicated in the operational sections of the specifications is not implied. Exposure to absolute maximum rating conditions for extended periods may affect device reliability.

**DC Electrical Characteristics**

( $V_{CC} = +5V \pm 5\%$ ,  $V_{BATT} = +5V$  to +42V,  $T_A = T_{MIN}$  to  $T_{MAX}$ , unless otherwise noted. Typical values are at  $V_{CC} = +5V$ ,  $V_{BATT} = 14V$ ,  $R1 = 100\Omega$ ,  $T_A = +25^\circ\text{C}$ .) (Notes 1, 2)

PARAMETER	SYMBOL	CONDITIONS	MIN	TYP	MAX	UNITS
<b>VOLTAGE SUPPLIES</b>						
Supply Current	$I_{CC}$	Dominant normal operating mode, no load, TXD = 0		16	30	mA
		Recessive normal operating mode, TXD = $V_{CC}$		4	10	
		Low-power modes: $V_{TXD} = V_{CC}$ , $V_{BATT} = 14V$		3	10	$\mu\text{A}$
Battery Current	$I_{BATT}$	Low-power modes at $V_{TRL} = V_{BATT}$ , $V_{BATT} = V_{WAKE} = V_{INH} = 5V$ to 27V	5	54	125	$\mu\text{A}$
Battery Power on Flag Threshold	$V_{PWRON}$	Low-power modes	1.0		3.5	V
<b>STB, EN, AND TXD</b>						
High-Level Input Voltage	$V_{IH}$		2.4			V
Low-Level Input Voltage	$V_{IL}$				0.8	V
High-Level Input Current	$I_{IH}$	$V_{IN} = 4V$	$\overline{STB}$ and EN	9	20	$\mu\text{A}$
			TXD	-200	-80	
Low-Level Input Current	$I_{IL}$	$V_{IN} = 1V$	$\overline{STB}$ and EN	4	8	$\mu\text{A}$
			TXD	-800	-320	
Supply Voltage—Forced Standby Mode (Fail-Safe)	$V_{FS}$	$V_{BATT} = 14V$	2.75		4.50	V
<b>RXD AND <math>\overline{ERR}</math></b>						
High-Level Output Voltage	$V_{OH}$	$I_{OUT} = -1\text{mA}$	$V_{CC} - 0.5$		$V_{CC}$	V
Low-Level Output Voltage	$V_{OL}$	$I_{OUT} = 7.5\text{mA}$	0		0.9	V
<b>WAKE</b>						
Wake-Up Threshold Voltage	$V_{TH(WAKE)}$	$V_{STB} = 0V$	2.0	2.7	3.4	V
Low-Level Input Current	$I_{IL(WAKE)}$	$V_{WAKE} = 0V$	-10	-4	-1	$\mu\text{A}$

**DC Electrical Characteristics (continued)**

( $V_{CC} = +5V \pm 5\%$ ,  $V_{BATT} = +5V$  to  $+42V$ ,  $T_A = T_{MIN}$  to  $T_{MAX}$ , unless otherwise noted. Typical values are at  $V_{CC} = +5V$ ,  $V_{BATT} = 14V$ ,  $R1 = 100\Omega$ ,  $T_A = +25^\circ C$ .) (Notes 1, 2)

PARAMETER	SYMBOL	CONDITIONS	MIN	TYP	MAX	UNITS
<b>INH</b>						
High-Level Voltage Drop	$\Delta V_H$	INH = -0.18mA, standby mode			0.8	V
Leakage Current	$I_{LEAK(INH)}$	Sleep mode, $V_{INH} = 0V$			5	$\mu A$
<b>CANH, CANL</b>						
Differential Receiver Threshold	$V_{DIFF}$	$V_{CC} = 5V$ , no failures and bus failures 1, 2, 5, 9	-3.5	-3.2	-2.9	V
		$V_{CC} = 4.75V$ to $5.25V$ , no failures and bus failures 1, 2, 5, 9	$-0.70 \times V_{CC}$		$-0.58 \times V_{CC}$	
Differential Receiver Hysteresis	HYST	No failures and bus failures 1, 2, 5, 9		18		mV
CANH Recessive Output Voltage	$V_{OCH}$	TXD = $V_{CC}$ , RTH < 4k $\Omega$			200	mV
CANL Recessive Output Voltage	$V_{OCL}$	TXD = $V_{CC}$ , RTH < 4k $\Omega$	$V_{CC} - 0.2$			V
CANH Dominant Output Voltage	$V_{OCHDOM}$	TXD = 0V, R1 = 100 $\Omega$	$V_{CC} - 1.4$			V
CANL Dominant Output Voltage	$V_{OCLDOM}$	TXD = 0V, R1 = 100 $\Omega$			1.4	V
CANH Output Current	$I_{O(CANH)}$	$V_{CANH} = 0V$ , TXD = 0V	-150	-86		mA
		Low-power modes, $V_{CANH} = 0V$ , $V_{CC} = 5V$	-10			$\mu A$
CANL Output Current	$I_{O(CANL)}$	$V_{CANL} = 14V$ , TXD = 0V		75	130	mA
		Low-power modes, $V_{CANL} = 42V$ , $V_{BATT} = 42V$ , RTL = open			20	$\mu A$
Voltage Detection Threshold for Short Circuit to Battery on CANH	$V_{DET(CANH)}$	$V_{CC} = 4.75V$ to $5.25V$	$0.30 \times V_{CC}$		$0.37 \times V_{CC}$	V
		Low-power modes	1.1		2.5	
Voltage Detection Threshold for Short Circuit to GND on CANL	$V_{DTG(CANL)}$	Low-power modes	2.5		3.9	V
Voltage Detection Threshold for Short Circuit to Battery on CANL	$V_{DET(CANL)}$	Normal mode, $V_{CC} = 5V$	6.4	7.3	8.2	V
CANL Wake-Up Threshold	$V_{THL(WAKE)}$	Low-power modes	2.5	3.2	3.9	V
CANH Wake-Up Threshold	$V_{THH(WAKE)}$	Low-power modes	1.1	1.8	2.5	V
CANH Single-Ended Receiver Threshold (Failures 4, 6, 7)	$V_{SE(CANH)}$	$V_{CC} = 5V$	1.50	1.70	1.85	V
		$V_{CC} = 4.75V$ to $5.25V$	$0.30 \times V_{CC}$		$0.37 \times V_{CC}$	
CANH Single-Ended Receiver Hysteresis	HYST			10		mV

**DC Electrical Characteristics (continued)**

( $V_{CC} = +5V \pm 5\%$ ,  $V_{BATT} = +5V$  to  $+42V$ ,  $T_A = T_{MIN}$  to  $T_{MAX}$ , unless otherwise noted. Typical values are at  $V_{CC} = +5V$ ,  $V_{BATT} = 14V$ ,  $R1 = 100\Omega$ ,  $T_A = +25^\circ C$ .) (Notes 1, 2)

PARAMETER	SYMBOL	CONDITIONS	MIN	TYP	MAX	UNITS
CANL Single-Ended Receiver Threshold	$V_{SE(CANL)}$	$V_{CC} = 5V$	3.15	3.30	3.45	V
		$V_{CC} = 4.75V$ to $5.25V$	$0.63 \times V_{CC}$		$0.69 \times V_{CC}$	
CANL Single-Ended Receiver Hysteresis	HYST	Failures 3, 8		10		mV
<b>RTL AND RTH</b>						
RTL to $V_{CC}$ Switch On-Resistance	$R_{SW(RTL)}$	$I_O = -10mA$		36	100	$\Omega$
RTH to $V_{CC}$ Switch On-Resistance	$R_{SW(RTH)}$	$I_O = 10mA$		23	100	$\Omega$
Output Current on Pin RTL	$I_{O(RTL)}$	Low-power modes, $V_{RTL} = 0$	-1.25	-0.65	-0.30	mA
RTL Pullup Current	$ I_{PU(RTL)} $	Normal and failures 4, 6, 7, $RTL = 0V$	20	107	200	$\mu A$
RTH Pulldown	$ I_{PU(RTH)} $	Normal and failures 3, 8, $RTL = V_{CC}$	20	106	200	$\mu A$
<b>THERMAL SHUTDOWN</b>						
Shutdown Junction Temperature	$T_J$	For shutdown		165		$^\circ C$
	$T_{JF6}$	During failure 6—switch off CANL only		140		
Thermal Protection Hysteresis	$T_{HYS}$			15		$^\circ C$

**AC Electrical Characteristics**

( $V_{CC} = +5V \pm 5\%$ ,  $V_{BATT} = +5V$  to  $+42V$ ,  $T_A = T_{MIN}$  to  $T_{MAX}$ , unless otherwise noted. Typical values are at  $V_{CC} = +5V$ ,  $V_{BATT} = 14V$ ,  $R1 = 100\Omega$ , and  $T_A = +25^\circ C$ .) (Notes 1, 2)

PARAMETER	SYMBOL	CONDITIONS	MIN	TYP	MAX	UNITS
<b>TRANSITION TIME</b>						
CANL and CANH Bus Output Transition Time Recessive to Dominant (10% to 90%)	$t_{(r-d)}$	$C_L = 330pF$ , MAX3054 (250kbps)		38		ns
		$C_L = 220pF$ to $3.3nF$ , MAX3055 (125kbps)	100		700	
		$C_L = 560pF$ to $10nF$ , MAX3056 (40kbps)	0.7		3.3	$\mu s$
CANL and CANH Bus Output Transition Time Dominant to Recessive (10% to 90%)	$t_{(d-r)}$	$C_L = 330pF$ , MAX3054 (250kbps)		130		ns
		$C_L = 220pF$ to $1nF$ , MAX3055 (125kbps)	200		1200	
		$C_L = 560pF$ to $3.3nF$ , MAX3056 (40kbps)	0.5		2.8	$\mu s$
<b>PROPAGATION DELAY TXD TO RXD LOW—DOMINANT TRANSMISSION (FIGURES 1, 2)</b>						
Differential Reception	$t_{PDLD}$	No failures, $C_L = 330pF$ , MAX3054 (250kbps)			600	ns
		Bus failures 1, 2, 5, 9, $C_L = 330pF$ , MAX3054 (250kbps)			750	
		No failures and bus failures 1, 2, 5, 9, $C_L = 1nF$ , MAX3055 (125kbps)			1.5	$\mu s$
		No failures and bus failures 1, 2, 5, 9, $C_L = 3.3nF$ , MAX3056 (40kbps)			4.7	

**AC Electrical Characteristics (continued)**

( $V_{CC} = +5V \pm 5\%$ ,  $V_{BATT} = +5V$  to  $+42V$ ,  $T_A = T_{MIN}$  to  $T_{MAX}$ , unless otherwise noted. Typical values are at  $V_{CC} = +5V$ ,  $V_{BATT} = 14V$ ,  $R1 = 100\Omega$ , and  $T_A = +25^\circ C$ .) (Notes 1, 2)

PARAMETER	SYMBOL	CONDITIONS	MIN	TYP	MAX	UNITS	
Single-Ended Reception	$t_{PDLSE}$	Bus failures 3, 4, 6, 7, 8, $C_L = 330pF$ , MAX3054 (250kbps)			750	ns	
		Bus failures 3, 4, 6, 7, 8, $C_L = 1nF$ , MAX3055 (125kbps)			1.5	$\mu s$	
		Bus failures 3, 4, 6, 7, 8, $C_L = 3.3nF$ , MAX3056 (40kbps)			4.7		
<b>PROPAGATION DELAY TXD TO RXD HIGH—RECESSIVE TRANSMISSION (FIGURES 1, 2)</b>							
Differential Reception	$t_{PDHD}$	No failures and bus failures 1, 2, 5, 9, $C_L = 330pF$ , MAX3054 (250kbps)			950	ns	
		No failures and bus failures 1, 2, 5, 9, $C_L = 1nF$ , MAX3055 (125kbps)			1.9	$\mu s$	
		No failures and bus failures 1, 2, 5, 9, $C_L = 3.3nF$ , MAX3056 (40kbps)			5.95		
Single-Ended Reception	$t_{PDHSE}$	Bus failures 3, 4, 6, 7, 8, $C_L = 330pF$ , MAX3054 (250kbps)			950	ns	
		Bus failures 3, 4, 6, 7, 8, $C_L = 1nF$ , MAX3055 (125kbps)			1.9	$\mu s$	
		Bus failures 3, 4, 6, 7, 8, $C_L = 3.3nF$ , MAX3056 (40kbps)			5.95		
<b>WAKE-UP TIMING</b>							
Minimum Time for Wake-Up on CANL and CANH or $\overline{WAKE}$	$t_{WAKE}$	$\overline{WAKE}$	8		38	$\mu s$	
<b>FAILURES TIMING</b>							
Failures 3 and 8 Detection Time	$t_{DET}$	Normal and low-power mode	MAX3054 (250kbps), MAX3055 (125kbps)	1.9	5.7	9.5	$ms$
			MAX3056 (40kbps)	5.5	16.5	27.0	
Failures 4 and 7 Detection Time		Normal and low-power mode	MAX3054 (250kbps), MAX3055 (125kbps)	0.3	1	1.9	
			MAX3056 (40kbps)	1.0	3.2	5.5	
Failure 6 Detection Time		Normal mode	MAX3054 (250kbps), MAX3055 (125kbps)	0.35	1.1	1.85	
			MAX3056 (40kbps)	0.93	2.97	5.00	

**AC Electrical Characteristics (continued)**

( $V_{CC} = +5V \pm 5\%$ ,  $V_{BATT} = +5V$  to  $+42V$ ,  $T_A = T_{MIN}$  to  $T_{MAX}$ , unless otherwise noted. Typical values are at  $V_{CC} = +5V$ ,  $V_{BATT} = 14V$ ,  $R1 = 100\Omega$ , and  $T_A = +25^\circ C$ .) (Notes 1, 2)

PARAMETER	SYMBOL	CONDITIONS		MIN	TYP	MAX	UNITS
Failures 3 and 8 Recovery Time		Normal and low-power mode	MAX3054 (250kbps), MAX3055 (125kbps)	0.36	1.14	1.90	ms
			MAX3056 (40kbps)	1.0	3.2	5.5	
Failures 4 and 7 Recovery Time	$t_{REC}$	Normal mode	MAX3054 (250kbps)	1.7	5.6	9.5	$\mu s$
			MAX3055 (125kbps)	7	23	38	
			MAX3056 (40kbps)	22	70	119	
Failure 6 Recovery Time		Low-power mode	MAX3054 (250kbps), MAX3055 (125kbps)	0.35	1.1	1.85	ms
			MAX3056 (40kbps)	1.0	3.2	5.5	
Minimum Hold Time of Go-to-Sleep Command	$t_{HMIN}$			5		50	$\mu s$
Disable Time of TXD Permanent Dominant Timer	$t_{DIS(TXD)}$	$V_{TXD} = 0$	MAX3054 (250kbps), MAX3055 (125kbps)	0.9		4.5	ms
			MAX3056 (40kbps)	2.34		12.50	
Pulse Count Difference for Failures 1, 2, 5, 9 Detection ( $\overline{ERR}$ Becomes Low)	Count			4			
Pulse Count Difference for Failures 1, 2, 5, 9 Recovery ( $\overline{ERR}$ Becomes High)			3	4	5		

**Note 1:** All currents into the device are positive; all currents out of the device are negative. All voltages are referenced to device ground, unless otherwise noted.

**Note 2:** Failure modes 1 through 9 are explained in Table 1 and in the *Detailed Description* section.

**Timing Diagrams/Test Circuits**

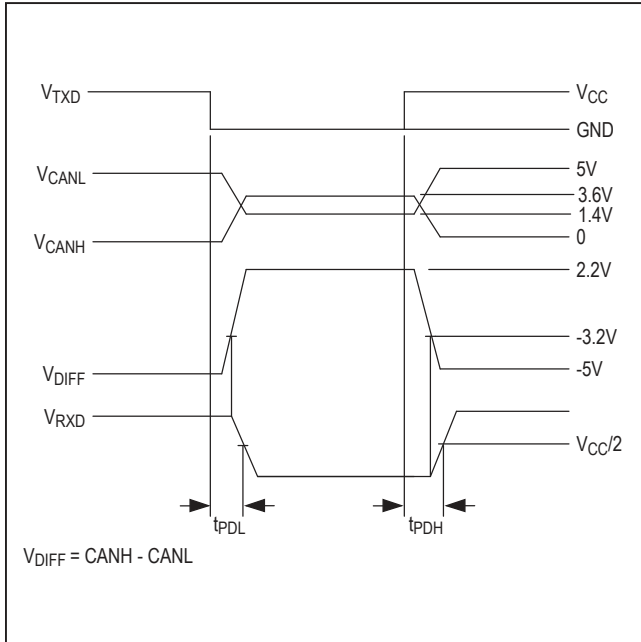

Figure 1. Timing Diagram for Dynamic Characteristic

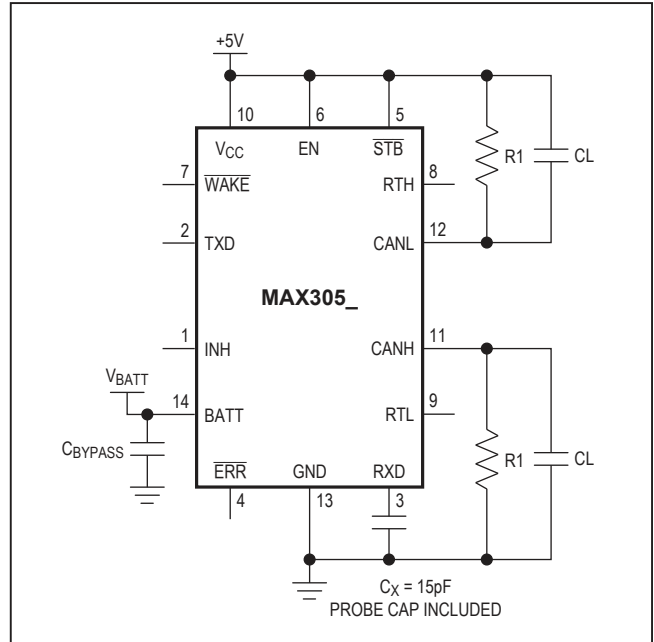

Figure 2. Test Circuit for Dynamic Characteristics

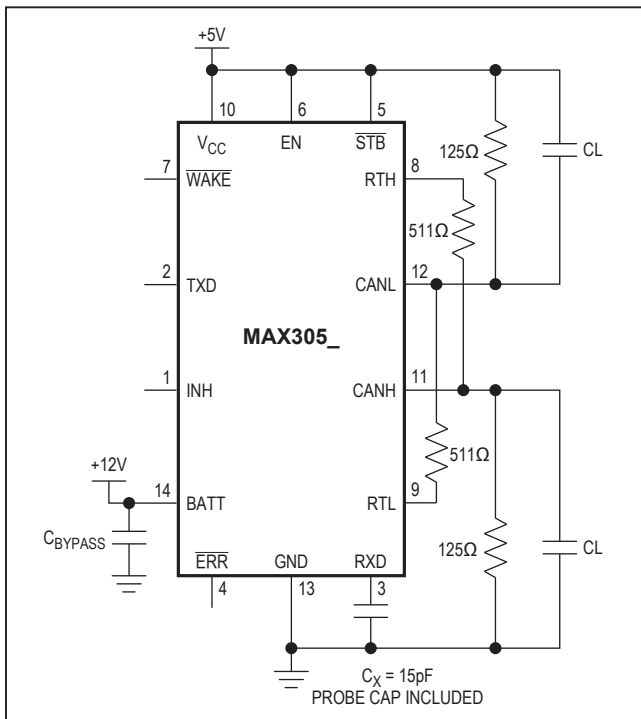
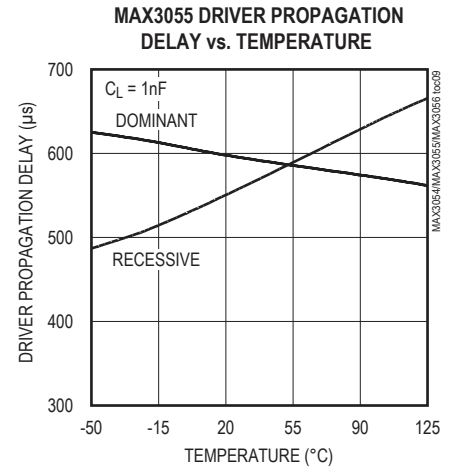
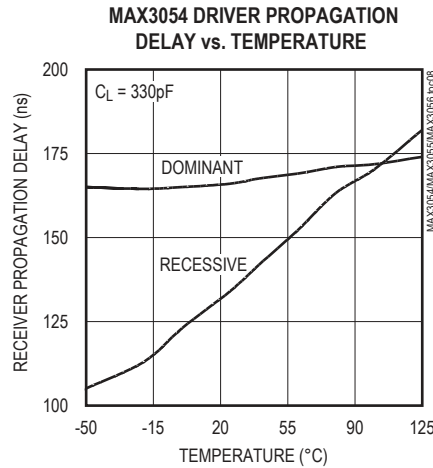
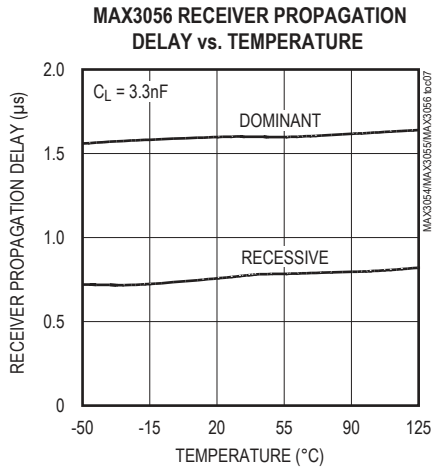
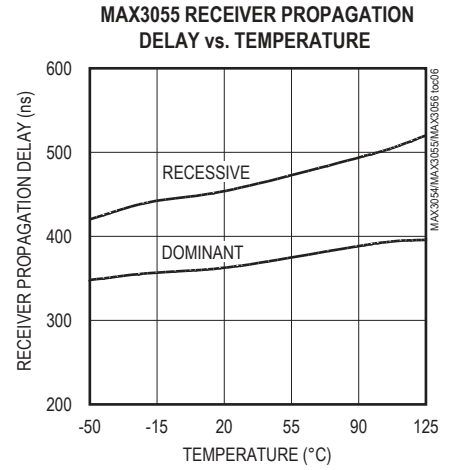
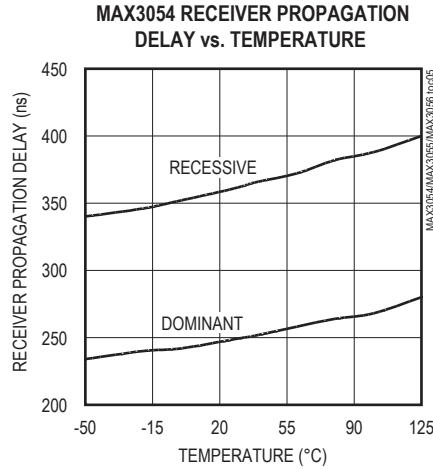
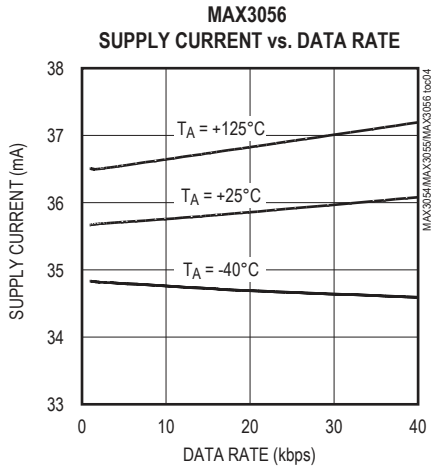
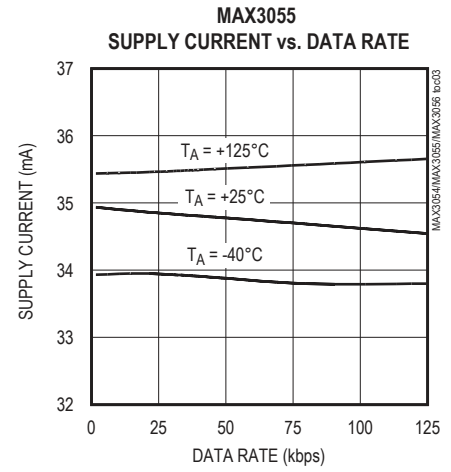
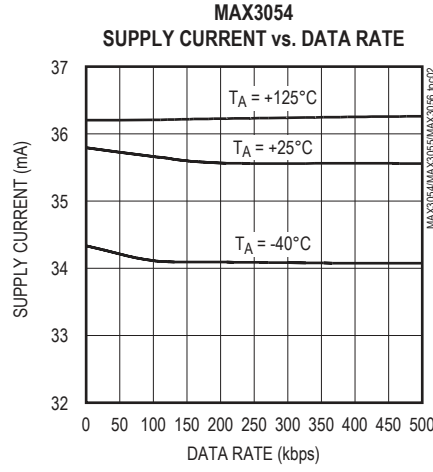
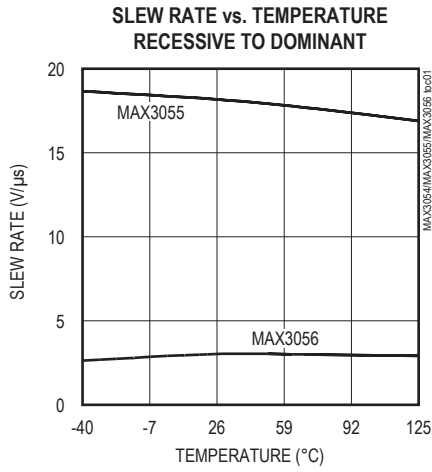

Figure 3. Test Circuit for Typical Operating Characteristics

**Typical Operating Characteristics**

( $V_{CC} = +5V$ ,  $V_{BATT} = 12V$ , and  $T_A = +25^\circ C$ .  $R_{TL} = R_{TH} = 511\Omega$ ,  $R_1 = 125\Omega$ , see Test Circuit Figure 3.)





**Typical Operating Characteristics (continued)**

( $V_{CC} = +5V$ ,  $V_{BATT} = 12V$ , and  $T_A = +25^\circ C$ .  $R_{TL} = R_{TH} = 511\Omega$ ,  $R_1 = 125\Omega$ , see Test Circuit Figure 3.)

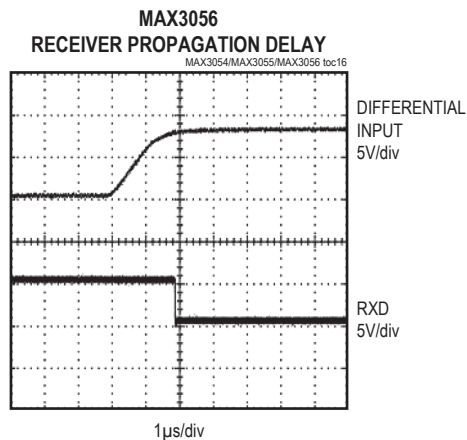
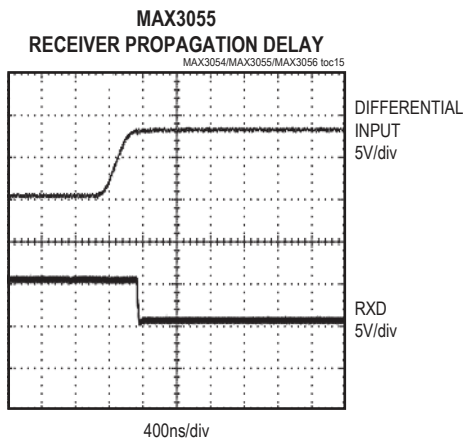
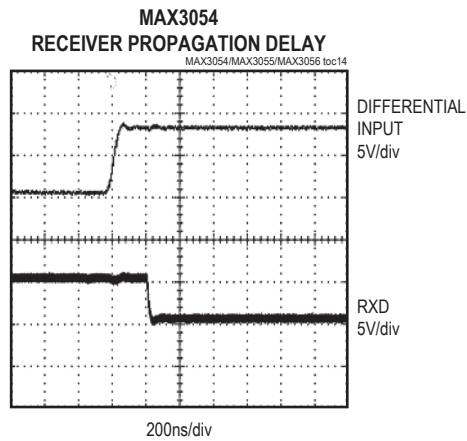
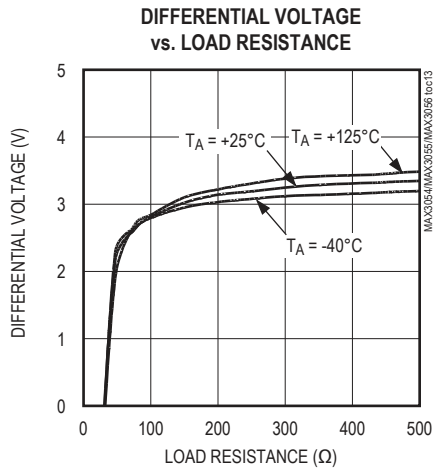
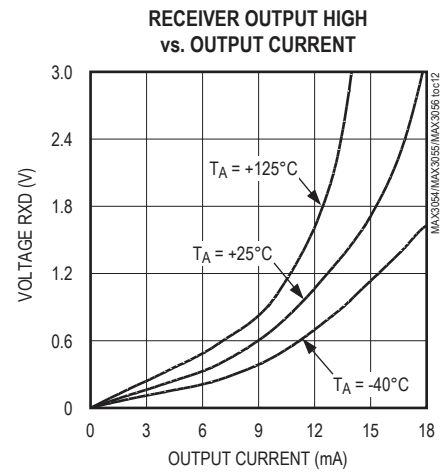
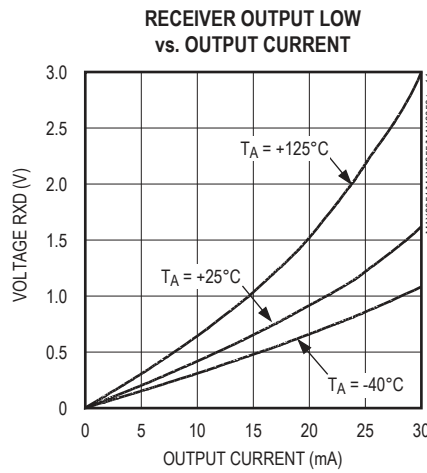
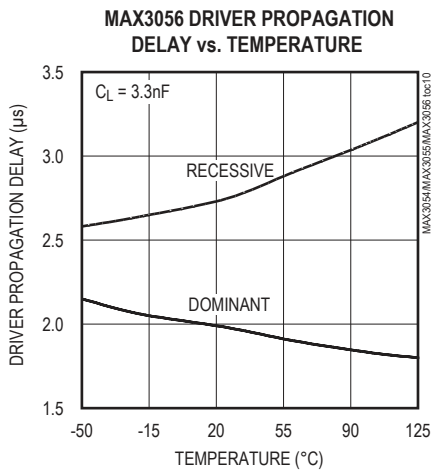

**Typical Operating Characteristics (continued)**

( $V_{CC} = +5V$ ,  $V_{BATT} = 12V$ , and  $T_A = +25^\circ C$ .  $R_{TL} = R_{TH} = 511\Omega$ ,  $R_1 = 125\Omega$ , see Test Circuit Figure 3.)

**DRIVER PROPAGATION DELAY  
RECESSIVE TO DOMINANT**

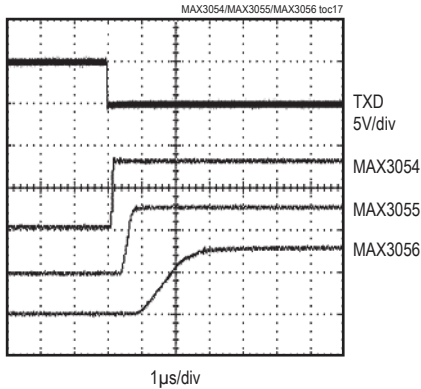

**DRIVER PROPAGATION DELAY  
DOMINANT TO RECESSIVE**

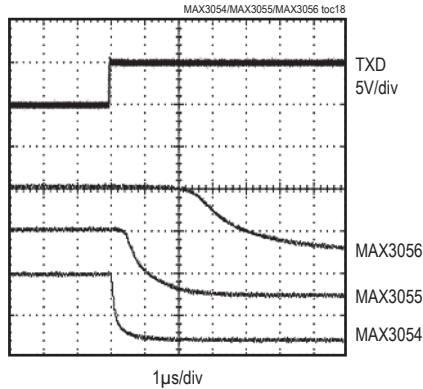

**TXD-TO-RXD PROPAGATION DELAY  
DOMINANT TO RECESSIVE**

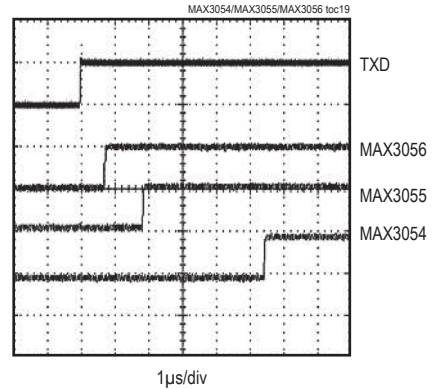

**TXD-TO-RXD PROPAGATION DELAY  
RECESSIVE TO DOMINANT**

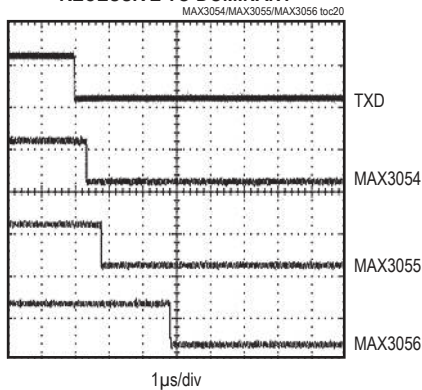

**MAX3056 CAN BUS AT 40kbps**

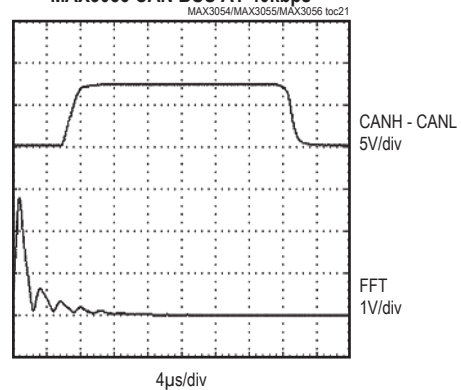

**MAX3055 CAN BUS AT 125kbps**

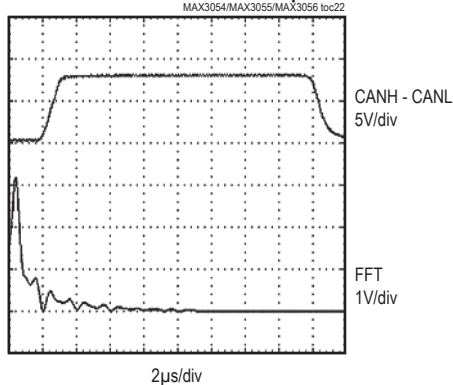

**MAX3054 CAN BUS AT 250kbps**

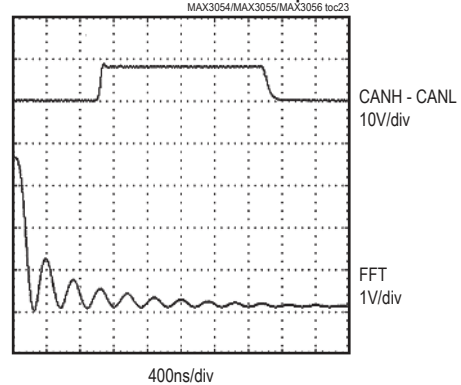

## Pin Description

PIN	NAME	FUNCTION
1	INH	Inhibit Output. Inhibit output is for switching an external voltage regulator if a wake-up signal occurs.
2	TXD	Transmit Data Input
3	RXD	Receive Data Output
4	$\overline{\text{ERR}}$	Error. Wake-up and power-on indication output; active low in normal operating mode when the bus has a failure and in low-power modes (wake-up signal or in power-on standby).
5	$\overline{\text{STB}}$	Standby. The digital control signal input (active low); defines together with input signal on pin EN, the state of the transceiver (in normal and low-power modes).
6	EN	Enable. The digital control signal input; defines together with input signal on pin $\overline{\text{STB}}$ the state of the transceiver (in normal and low-power modes).
7	$\overline{\text{WAKE}}$	Wake-Up. Local wake-up signal input; falling and rising edges are both detected.
8	RTH	Termination Resistor. Termination resistor connection for CANH bus.
9	RTL	Termination Resistor. Termination resistor connection for CANL bus.
10	V <sub>CC</sub>	Supply Voltage. Bypass to ground with a 0.1μF capacitor.
11	CANH	HIGH-Level Voltage Bus line
12	CANL	LOW-Level Voltage Bus line
13	GND	Ground
14	BATT	Battery Supply. Bypass to ground with a 0.1μF capacitor.

## Detailed Description

The MAX3054/MAX3055/MAX3056 interface between the protocol controller and the physical wires of the bus lines in a CAN. The devices provide differential transmit capability and switch to single-wire mode if certain fault conditions occur (see the *Failure Management* section). The MAX3054/MAX3055/MAX3056 guarantee full wake-up capability during failure modes.

The extended fault-protection range of CANH and CANL bus lines (±80V). A current-limiting circuit protects the transmitter output stage against overcurrent faults. This feature prevents destruction of the transmitter output stage. If the junction temperature exceeds a value of approximately +165°C, the transmitter output stages are disabled. The CANH and CANL lines are also protected against electrical transients, which can occur in harsh environments.

The transceiver provides three low-power modes that can be entered and exited through pins  $\overline{\text{STB}}$  and EN. An output INH pin can be used for deactivation of an external voltage regulator.

The MAX3054/MAX3055/MAX3056 are designed to provide optimal operation for a specified data rate. The MAX3054 is ideal for high data rates of 250kbps. The

MAX3055 is used for data rates of 125kbps and the MAX3056 is designed for 40kbps applications. For the 40kbps and 125kbps versions, the built-in slope-control feature allows the use of unshielded cables and receiver input filters guarantee high noise immunity.

### Normal Operation Mode

#### Transmitter

The transmitter converts a single-ended input (TXD) from the CAN controller to differential outputs for the bus lines (CANH, CANL).

#### Receiver

The receiver takes differential input from the bus lines (CANH, CANL) and converts this data as a single-ended output (RXD) to the CAN controller. It consists of a comparator that senses the difference  $\Delta V = (\text{CANH} - \text{CANL})$  with respect to an internal threshold.

#### BATT

The main function of BATT is to supply power to the device when a +12V battery voltage is supplied.

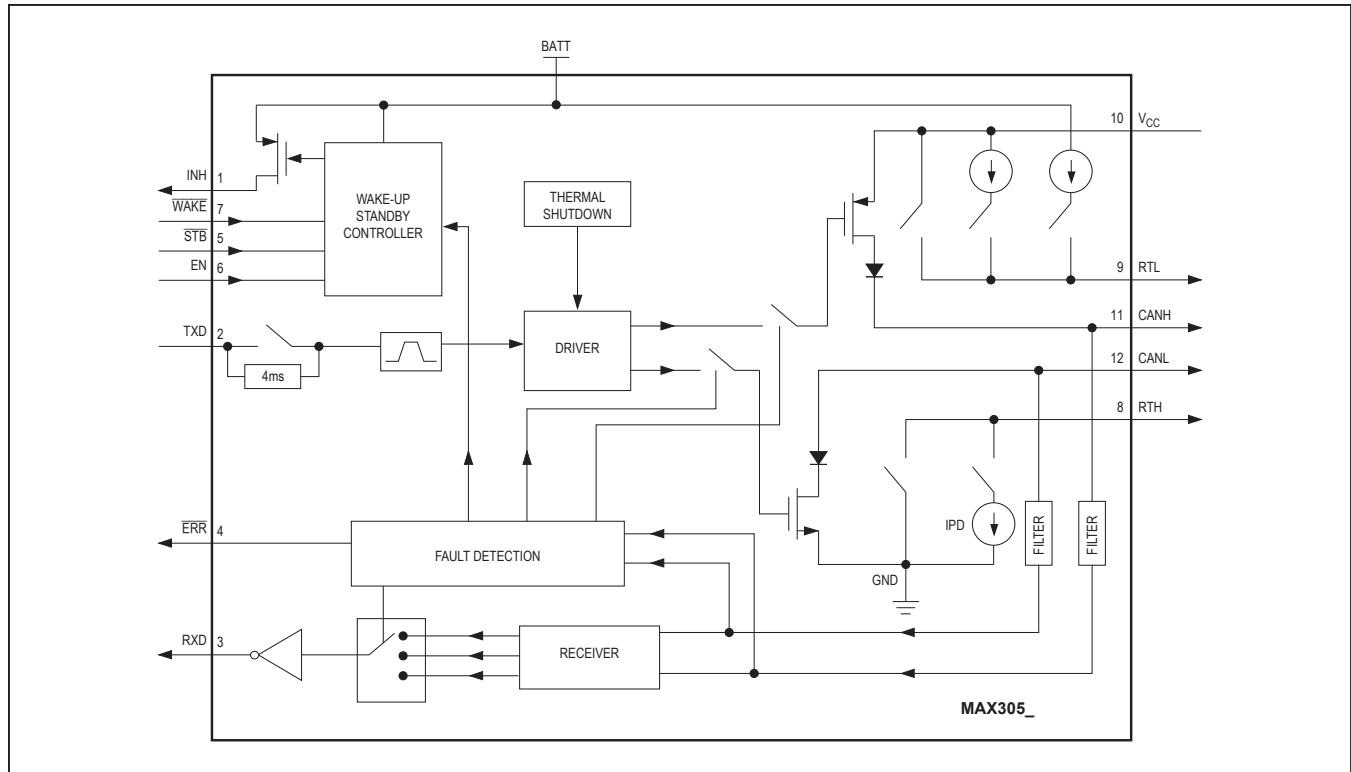

Figure 5. Block Diagram

### INH

Inhibit is an output that allows for the control of an external voltage regulator. On a wake-up request or power-up on BATT, the transceiver sets the output INH high. This feature enables the external voltage regulator to be shut down during sleep mode to reduce power consumption.

INH is floating while entering the sleep mode and stays floating during the sleep mode. If INH is left floating, it is not set to a high level again until the following events occur:

- Power-on ( $V_{BATT}$  switching on at cold start)
- Rising or falling edge on  $\overline{WAKE}$
- Dominant signal longer than  $38\mu s$  during EN or  $\overline{STB}$  at low level

The signals on  $\overline{STB}$  and EN are internally set to low level when  $V_{CC}$  is below a certain threshold voltage providing fail-safe functionality.

After power-on ( $V_{BATT}$  switched on) the signal on INH becomes HIGH and an internal power-on flag is set. This flag can be read in the power-on standby mode through ERR ( $STB = 1$ ,  $EN = 0$ ) and is reset by entering the normal operating mode.

### $\overline{ERR}$

$\overline{ERR}$  is a wake-up and power-on indicator as well as an error detector. Upon power-up, wake up, or when a bus failure is detected, the output signal on  $\overline{ERR}$  becomes LOW. Upon error recovery, the output signal on  $\overline{ERR}$  is set HIGH.

### $\overline{STB}$

$\overline{STB}$  is the standby digital control signal into the logic controller. This is an active-low input that is used with EN to define the status of the transceiver in normal and low-power modes.

### EN

EN is the enable digital control signal into the logic controller used in conjunction with  $\overline{STB}$  to define the status of the transceiver in normal and low-power modes.

### $\overline{WAKE}$

$\overline{WAKE}$  is an input to the logic controller within the device to signal a wake-up condition. If  $\overline{WAKE}$  receives a positive or negative pulse for a period longer than  $t_{\overline{WAKE}}$ , wake up occurs.

**Driver Output Protection**

**Thermal Shutdown**

If the junction temperature exceeds +165°C the driver is switched off. Thermal hysteresis is 15°C, disabling thermal shutdown once the temperature reaches +150°C.

**Overcurrent Protection**

A current-limiting circuit protects the transmitter output stage against a short circuit to a positive and negative battery voltage. Although the power dissipation increases during this fault condition, this feature prevents destruction of the transmitter output stage.

**Failure Management**

The failure detector is fully active in normal operating mode. After the detection of a single failure the detector switches to the appropriate state (see [Table 1](#)).

The differential receiver threshold voltage is set to -3.2V typically ( $V_{CC} = 5V$ ). This ensures correct reception with a noise margin as high as possible in the normal operating mode and in the event of failure 1, 2, 5, 9.

If any of the wiring failures occur, the output signal on pin  $\overline{ERR}$  becomes LOW after detection. On error recovery, the output signal on pin  $\overline{ERR}$  becomes HIGH.

**Table 1. Failure States**

FAILURE	DESCRIPTION	MODE
1	CANH wire interrupted	Normal
2	CANL wire interrupted	Normal
3	CANH short circuited to battery	All
4	CANL short circuited to ground	All
5	CANH short circuited to ground	Normal
6	CANL short circuited to battery	Normal
7	CANL mutually short circuited to CANH	All
8	CANH short circuited to Vcc	All
9	CANL short circuited to Vcc	Normal

**Failure 1—CANH Wire Interrupted (Normal Mode Only)**

MODE	DESCRIPTION
Detection	The external termination resistance connected to the RTH pin provides an instantaneous pulldown of the open CANH line to GND. Detection is provided, sensing the pulse-count difference between CANH and CANL (pulse count = 4).
Receiver	The receiver remains in differential mode. No received data lost.
Driver	Driver remains in differential mode. No transmission data lost.
Recovery	Recovery is provided sensing the pulse-count difference between CANH and CANL after the detection of four consecutive pulses.

**Failure 2—CANL Wire Interrupted (Normal Mode Only)**

MODE	DESCRIPTION
Detection	The external termination resistance connected to the RTL pin provides an instantaneous pullup of the CANL line to $V_{CC}$ . Detection is provided, sensing the pulse-count difference between CANL and CANH (pulse count = 4).
Receiver	The receiver remains in differential mode. No received data lost.
Driver	Driver remains in differential mode. No transmission data lost.
Recovery	Recovery is provided, sensing the pulse-count difference between CANL and CANH after the detection of four consecutive pulses.

**Table 1. Failure States (continued)**

**Failure 3—CANH Short-Circuited to Battery**

MODE	DESCRIPTION
Detection	Sensing a permanent dominant condition on CANH for a timeout period.
Receiver	Receiver switches to single ended on CANL.
Driver	CANH and RTH are both switched off (high impedance) and transmission continues on CANL after timeout.
Recovery	When the short is removed, the recessive bus voltage is restored. If the differential voltage remains below the recessive threshold level for the timeout period, reception and transmission switch back to the differential mode.

**Failure 4—CANL Short-Circuited to GND**

MODE	DESCRIPTION
Detection	Sensing a permanent dominant condition for a timeout period.
Receiver	Receiver switches to single ended on CANH.
Driver	CANL and RTL are both switched off (high impedance) and transmission continues on CANH after timeout.
Recovery	When the short is removed, the recessive bus voltage is restored. If the differential voltage remains below the recessive threshold level for the timeout period, reception and transmission switch back to the differential mode.

**Failure 5—CANH Short-Circuited to Ground or Below Ground (Normal Mode Only)**

MODE	DESCRIPTION
Detection	Detection is provided, sensing the pulse-count difference between CANH and CANL (pulse count = 4).
Receiver	Receiver remains in differential mode. No received data lost.
Driver	RTH remains on and CANH remains enabled.
Recovery	Recovery is provided, sensing the edge-count difference between CANH and CANL after the detection of four consecutive pulses.

**Failure 6—CANL Short-Circuited to Battery (Normal Mode Only)**

MODE	DESCRIPTION
Detection	Detected by a comparator for CANL > 7.3V after a timeout period.
Receiver	Receiver switches to single ended on CANH after timeout.
Driver	RTL is switched off after timeout. CANH remains active.
Recovery	Sensing CANL < 7.3V after the timeout period.

**Failure 7—CANL Mutually Short-Circuited to CANH**

MODE	DESCRIPTION
Detection	Sensing a permanent dominant condition on the differential comparator (CANH - CANL > -3.2V) for the timeout period.
Receiver	Receiver switches to CANH single-ended mode after timeout.
Driver	CANL and RTL are both switched off after timeout. Transmission remains ongoing on CANH.
Recovery	When the short is removed, the recessive bus voltage is restored (RTL on if CANH - CANL < -3.2V) but CANL still remains disabled and ERR = 0. If the differential voltage remains below the recessive threshold level (CANH - CANL < -3.2V) for the timeout period, reception and transmission switch back to the differential mode.

**Table 1. Failure States (continued)  
Failure 8—CANH Short-Circuited to V<sub>CC</sub>**

MODE	DESCRIPTION
Detection	Sensing a permanent dominant condition on CANH for a timeout period.
Receiver	Receiver switches to single ended on CANL. Data lost (permanent dominant) during timeout.
Driver	CANH and RTH are both switched off (high impedance) and transmission continues on CANL after timeout. Only a weak pulldown current on pin RTH remains.
Recovery	When the short is removed (CANH < 1.7V) and after a timeout, CANL is forced recessive (CANL off) and CANH is enabled (RTH on and CANH enabled). Signal can be transmitted or received in single ended on CANH and ERR remains low. If the differential voltage remains below the recessive threshold level (CANH - CANL < -3.2V) for a second timeout, reception and transmission switch back to the differential mode and ERR is released high.

**Failure 9—CANL Short-Circuited to V<sub>CC</sub> (Normal Mode Only)**

MODE	DESCRIPTION
Detection	Detection is provided, sensing the pulse-count difference between CANL and CANH (pulse count = 4).
Receiver	Receiver remains in differential mode. No received data lost.
Driver	Driver remains in differential mode. No transmission data lost.
Recovery	Recovery is provided, sensing the pulse-count difference between CANL and CANH after the detection of four consecutive pulses.

**Table 2. Summary of the Driver Outputs and Internal Switches State During Fault Conditions**

FAILURE NO.	DESCRIPTION	MODE	INTERNAL SWITCHES STATE	DRIVER OUTPUTS STATE	
				CANH	CANL
No failure	—	Normal	RTH, RTL on	Enabled	Enabled
No failure	—	Low power	RTH, I_RTL on	Disabled	Disabled
1	CANH wire interrupted	Normal	RTH, RTL on	Enabled	Enabled
2	CANL wire interrupted	Normal	RTH, RTL on	Enabled	Enabled
3	CANH short to BATT	All	RTH off	Disabled	Enabled
4	CANL short to GND	All	RTL or I_RTL off	Enabled	Disabled
5	CANH short to GND	Normal	RTH, RTL on	Enabled	Enabled
6	CANL short to BATT	Normal	RTL off, RTH on	Enabled	Enabled
7	CANL short to CANH	All	RTL or I_RTL off	Enabled	Disabled
8	CANH short to V <sub>CC</sub>	All	RTH off	Disabled	Enabled
9	CANL short to V <sub>CC</sub>	Normal	RTH, RTL on	Enabled	Enabled

**Note:** The RTH-pulldown current switch and the RTL-pullup current switch are closed in normal mode with or without fault conditions, open in sleep mode.



**Low-Power Modes**

The transceiver provides three low-power modes that can be entered or exited through pins  $\overline{STB}$  and EN (Table 3).

**Sleep Mode**

The sleep mode is the mode with the lowest power consumption. INH is switched to high impedance for deactivation of the external voltage regulator. CANL is biased to the battery voltage through RTL. If the supply voltage is provided, RXD and  $\overline{ERR}$  signal the wake-up interrupt.

**Standby Mode**

The standby mode reacts the same as the sleep mode but with a HIGH level on INH. Standby mode can be used when the external voltage regulator needs to be kept active during low-power operation.

**Power-On Standby Mode**

The power-on standby mode behaves similarly to the standby mode with the battery power-on flag of the wake-up interrupt signal on  $\overline{ERR}$ . This mode is only for reading the power-on flag. INH can be high or low in the power-on standby mode. When the device goes from standby mode to power-on standby mode, INH is HIGH. When the device goes from sleep mode to power-on standby mode, INH is low.

**Wake-Up**

Wake-up requests are recognized by the transceiver when a dominant signal is detected on either bus line or if WAKE detects a pulse for more than 38µs. On a wake-up request, INH is set high to activate an external voltage regulator.

If  $V_{CC}$  is provided, the wake-up request can be read on the  $\overline{ERR}$  or RXD outputs.

To prevent false wake-up due to transients or RF fields, the wake-up voltage levels have to be maintained for more than 38µs. In the low-power modes, the failure detection circuit remains partly active to prevent increased power consumption in the event of failures 3, 4, 7, and 8.

**Applications Information**

The MAX3054/MAX3055/MAX3056 are capable of sustaining a network of up to 32 transceivers on a single bus. The fault-tolerant transceivers are designed to operate at a total termination resistance of 100Ω. Both CANH and CANL lines are terminated with 100Ω. Since the total termination resistance of the system is distributed over the entire bus, each of the transceivers contributes only part of the total 100Ω termination. The values of the termination resistors RTL and RTH vary according to the size of the system and need to be calculated. It is not required that each transceiver be terminated with the same value, the total termination need only be a total 100Ω.

The minimum termination resistor value allowed for each transceiver is 500Ω, due to the driving capability of RTH and RTL. This makes it impossible to achieve a total termination resistance of 100Ω for systems smaller than five transceivers. Typically this does not create a problem because smaller systems usually have shorter bus cables and have no problem with higher total termination resistance.

To reduce EMI in the case of an interrupted bus wire it is recommended not to exceed 6kΩ termination resistance at a single transceiver even though a higher value is specified.

**Table 3. Low-Power Modes**

MODE	$\overline{STB}$	EN	$\overline{ERR}$		RXD		RTL SWITCHED TO
			LOW	HIGH	LOW	HIGH	
Go-to-Sleep Command	0	1	Wake-up interrupt signal (Notes 2 and 3)	—	Wake-up interrupt signal (Notes 2 and 3)	—	$V_{BATT}$
Sleep	0	0 (Note 1)					
Standby	0	0					
Power-On Standby	1	0	$V_{BATT}$ power-on flag	—	Wake-up interrupt signal (Notes 2 and 3)	—	$V_{BATT}$
Normal Operating	1	1	Error flag	No error flag	Dominant received data	Recessive received data	$V_{CC}$

**Note 3:** In case the go-to-sleep command was used before.

**Note 4:** If the supply voltage  $V_{CC}$  is present.

**Note 5:** Wake-up interrupts are released when entering the normal operating mode.



### **Reduced EMI and Reflections**

Due to internal slope control for the MAX3055/MAX3056, the CANH and CANL outputs are slew-rate limited. This minimizes EMI and reduces reflections caused by improperly terminated cables. In general, a transmitter's rise time relates directly to the length of an unterminated stub, which can be driven with only minor waveform reflections. The following equation expresses this relationship conservatively:

$$\text{Length} = t_{\text{RISE}}/(15\text{ns/ft})$$

where  $t_{\text{RISE}}$  is the transmitter's rise time.

The MAX3054/MAX3055/MAX3056 require no special layout considerations beyond common practices. Bypass  $V_{\text{CC}}$  to GND with a 0.1 $\mu\text{F}$  ceramic capacitor mounted close to the IC with short lead lengths and wide trace widths.

### **Chip Information**

TRANSISTOR COUNT: 1300

PROCESS: BiCMOS

## Package Information

### 8 SO

PACKAGE CODE	S8+5
Outline Number	<a href="#">21-0041</a>
Land Pattern Number	<a href="#">90-0096</a>

For the latest package outline information and land patterns (footprints), go to [www.maximintegrated.com/packages](http://www.maximintegrated.com/packages). Note that a “+”, “#”, or “-” in the package code indicates RoHS status only. Package drawings may show a different suffix character, but the drawing pertains to the package regardless of RoHS status.

Package thermal resistances were obtained using the method described in JEDEC specification JESD51-7, using a four-layer board. For detailed information on package thermal considerations, refer to [www.maximintegrated.com/thermal-tutorial](http://www.maximintegrated.com/thermal-tutorial).

**Revision History**

<b>REVISION NUMBER</b>	<b>REVISION DATE</b>	<b>DESCRIPTION</b>	<b>PAGES CHANGED</b>
0	11/02	Initial Release.	—
1	9/14	Removed Automotive designation.	1
2	2/21	Revised <i>Package Information</i> and added <i>Revision History</i> .	18, 19



*Information furnished by Analog Devices is believed to be accurate and reliable. However, no responsibility is assumed by Analog Devices for its use, nor for any infringements of patents or other rights of third parties that may result from its use. Specifications subject to change without notice. No license is granted by implication or otherwise under any patent or patent rights of Analog Devices. Trademarks and registered trademarks are the property of their respective owners.*