

THIS DRAWING IS UNPUBLISHED. RELEASED FOR PUBLICATION 20
 © COPYRIGHT 20 BY TYCO ELECTRONICS CORPORATION. ALL RIGHTS RESERVED.

LOC	DIST	REVISIONS					
CE	16	P	LTR	DESCRIPTION	DATE	DWN	APVD
		M		REVISED PER 0A00-0235-01	23JAN2002	TA	BE
		N		REVISE PER 0A00-0349-02	16APR2002	BB	DK

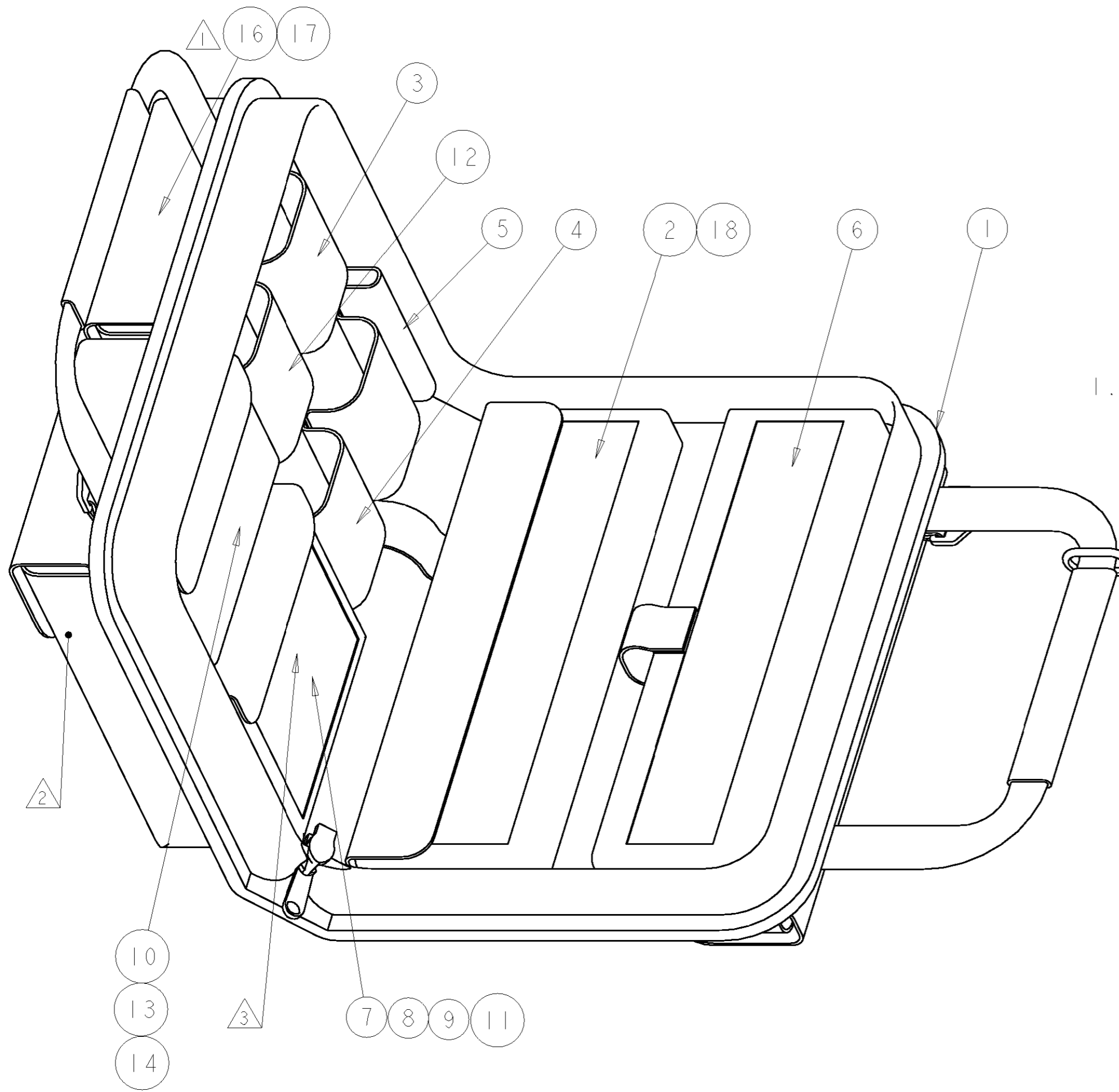

- △ 1 AMP INSTRUCTION SHEETS AND MANUFACTURERS' INSTRUCTION SHEETS
- △ 2 OPTIONAL SHOULDER STRAP
- △ 3 PLACE 2.5mm UNIVERSAL ADAPTER FROM MICROSCOPE 502978-1, ITEM 17, INTO POCKET.

QTY	UNIT	DESCRIPTION	PART NUMBER	ITEM
-	-	BALL END HEX KEY (5)	1457999-1	18
1	1	CD-ROM, MT-RJ TERM TRAINING	1435138-1	17
1	1	CD - ROM, TERMINATION TRAINING	1374503-1	16
-	-	LABEL, TERMINATION KIT	1374331-1	15
-	-	STRIP TEMPLATE, MT-RJ	1278598-1	14
-	-	ACTUATION KEY, MT-RJ	1278576-1	13
-	-	MICRO-STRIPPER, MT-RJ	492109-2	12
-	-	OPTIMATE CABLE STRIPPER	501198-1	11
-	-	ALCOHOL FIBER WIPE	501857-2	10
-	-	CABLE/BUFFER HOLDER,LightCrimp Plus AMP SC	1278023-1	9
-	-	CABLE/BUFFER HOLDER,LightCrimp Plus ST-STYLE	492703-1	8
-	-	LightCrimp Plus DIESET, ST-STYLE	492622-1	7
-	-	LightCrimp Plus PROCRIMPER W/DIESET,AMP SC	492782-1	6
2	2	WRENCH, 1/4 OPEN END	1278422-1	5
1	1	KEVLAR SHEARS	1278637-1	4
1	1	STRIP TOOL,FIBER,COMBINATION	1278947-1	3
-	-	CLEAVE TOOL, S-315	492674-1	2
1	1	PREMIUM SOFTCASE	1278540-1	1
-3	-2	DESCRIPTION	PART NUMBER	ITEM

SCALE 1:2

THIS DRAWING IS A CONTROLLED DOCUMENT FOR TYCO ELECTRONICS CORPORATION IT IS SUBJECT TO CHANGE AND THE CONTROLLING ENGINEERING ORGANIZATION SHOULD BE CONTACTED FOR THE LATEST REVISION.		DWN 15NOV2000 I. ALEXANDER CHK 15NOV2000 M. HAMONKO APVD 15NOV2000 S. BUCHTER	AMP Tyco Electronics Harrisburg, PA 17105-3608
DIMENSIONS: INCHES 	TOLERANCES UNLESS OTHERWISE SPECIFIED: 0 PLC ± 1 PLC ±0.1 2 PLC ±0.02 3 PLC ±0.005 4 PLC ±0.0005 ANGLES ± FINISH -	PRODUCT SPEC - APPLICATION SPEC - WEIGHT -	NAME TERMINATION KIT, COMBINATION, LightCrimp Plus AND MT-RJ JACK SIZE A2 CAGE CODE 00779 DRAWING NO. 1278118 RESTRICTED TO - SCALE 1:2 SHEET 1 OF 1 REV N
MATERIAL -		CUSTOMER DRAWING	